

AGREEMENT NO. _____

AGREEMENT BETWEEN
THE CITY OF LOS ANGELES AND
AMERICAN MARINE CORPORATION

THIS AGREEMENT ("Agreement") is made and entered into by and between the CITY OF LOS ANGELES, a municipal corporation ("City"), acting by and through its Board of Harbor Commissioners ("Board") and AMERICAN MARINE CORPORATION, a California corporation, located at 1500 South Barracuda Street, Terminal Island, CA 90731 ("Consultant").

WHEREAS, City requires underwater hard hat diving services to support ongoing operations involving maintenance and construction activities at POLA. The activities include wharf pile inspections, pile wrapping, wharf repair, and other miscellaneous services; and

WHEREAS, the Port of Los Angeles does not have any City classification that calls for the ability to perform underwater diving work involving inspection, repair work and operation of specialized underwater hard hat diving equipment; and

WHEREAS, Executive Director requires the professional, expert and technical services of Consultant on a temporary or occasional basis to assist the City in performing ongoing operations involving underwater maintenance, construction activities and other diving services; and

WHEREAS, Consultant possesses extensive experience in dealing with inspection and evaluation of the condition of wharf structure, fender piles, slope, seawall; marine facilities and equipment repair and construction; wharf damage inspection including preparation of written reports; and

WHEREAS, Consultant, by virtue of training and experience, is well qualified to provide such services to City; and

WHEREAS, City does not employ personnel with the required expertise nor is it feasible to do so on a temporary or occasional basis;

NOW, THEREFORE, IT IS MUTUALLY AGREED AS FOLLOWS:

I. SERVICES TO BE PERFORMED BY CONSULTANT

A. Consultant hereby agrees to render to City, as an independent contractor, certain professional, technical and expert services of a temporary and occasional character as set forth in Exhibit A ("Scope of Work").

B. Consultant, at its sole cost and expense, shall furnish all services, materials, equipment, subsistence, transportation and all other items necessary to perform the Scope of Work. As between City and Consultant, Consultant is solely responsible for any taxes or fees which may be assessed against it or its employees resulting from performance of the Scope of Work, whether social security, payroll or other, and regardless of whether assessed by the federal government, any state, the City, or any other governmental entity.

C. Consultant acknowledges and agrees that it lacks authority to perform any services outside the Scope of Work. Consultant further acknowledges and agrees that any services it performs outside the Scope of Work are performed as a volunteer and shall not be compensable under this Agreement.

D. The Scope of Work shall be performed by personnel qualified and competent in the sole reasonable discretion of the Executive Director or his or her designee ("Executive Director"), whether performance is undertaken by Consultant or third-parties with whom Consultant has contracted ("Subconsultants"). Obligations of this Agreement, whether undertaken by Consultant or Subconsultants, are and shall be the responsibility of Consultant. Consultant acknowledges and agrees that this Agreement creates no rights in Subconsultants with respect to City and that obligations that may be owed to Subconsultants, including, but not limited to, the obligation to pay Subconsultants for services performed, are those of Consultant alone. Upon Executive Director's written request, Consultant shall supply City's Harbor Department ("Department") with all agreements between it and its Subconsultants.

II. SERVICES TO BE PERFORMED BY CITY

A. City shall furnish Consultant, upon its request, all documents and papers in possession of City which may lawfully be supplied to Consultant and which are necessary for it to perform its obligations.

B. The Executive Director or his or her designee is designated as the contract administrator for City and shall also decide any and all questions which may arise as to the quality or acceptability of the services performed and the manner of performance, the interpretation of instructions to Consultant and the acceptable completion of this Agreement and the amount of compensation due. Notwithstanding the preceding, the termination of this Agreement shall be governed by the provisions of Article X (Termination) hereof.

C. Consultant shall provide Executive Director with reasonable advance written notice if it requires access to premises of Department. Subsequent access rights, if any, shall be granted to Consultant at the sole reasonable discretion of Executive Director, specifying conditions Consultant must satisfy in connection with such access. Consultant acknowledges that such areas may be occupied or used by tenants or contractors of City and that access rights granted by Department to Consultant shall be consistent with any such occupancy or use.

III. EFFECTIVE DATE AND TERM OF AGREEMENT

A. Subject to the provisions of Charter Section 245, the effective date of this Agreement shall be the date of its execution by Executive Director upon authorization of the Board. Consultant is aware that the City Council, pursuant to Charter Section 245 of the City of Los Angeles, has the right to review this Agreement. Accordingly, in no event shall this Agreement become effective until the sixth Council meeting day after Board action or the City Council's approval of the Agreement.

B. This Agreement shall be in full force and effect commencing from the date of execution by the Executive Director and shall be for an initial period of one (1) year, subject to the following:

1. The Executive Director has the option to renew the term of the Agreement for two (2) consecutive renewal periods of one (1) year each, for a total Agreement term not to exceed three (3) years from the effective date. Exercise of the option to renew shall be by written notice from the Executive Director to Consultant prior to the end of the current term of the Agreement; or

2. The Board of Harbor Commissioners, in its sole discretion, terminates and cancels all or part of this Agreement for any reason upon giving to Consultant ten (10) days notice in writing of its election to cancel and terminate this Agreement.

IV. TERMINATION DUE TO NON-APPROPRIATION OF FUNDS

This Agreement is subject to the provisions of the Los Angeles City Charter which, among other things, precludes the City from making any expenditure of funds or incurring any liability, including contractual commitments, in excess of the amount appropriated thereof.

The Board, in awarding this Agreement, is expected to appropriate sufficient funds to meet the estimated expenditure of funds through June 30 of the current fiscal year and to make further appropriations in each succeeding fiscal year during the life of the Agreement. However, the Board is under no legal obligation to do so.

The City, its boards, officers, and employees are not bound by the terms of this Agreement or obligated to make payment thereunder in any fiscal year in which the Board does not appropriate funds therefore. The Consultant is not entitled to any compensation in any fiscal year in which funds have not been appropriated for the Agreement by the Board.

Although the Consultant is not obligated to perform any work under the Agreement in any fiscal year in which no appropriation for the Agreement has been made, the Consultant agrees to resume performance of the work required by the Agreement on the same terms and conditions for a period of sixty (60) days after the

end of the fiscal year if an appropriation therefore is approved by the Board within that 60-day period. The Consultant is responsible for maintaining all insurance and bonds during this 60-day period until the appropriation is made; however, such extension of time is not compensable.

If in any subsequent fiscal year funds are not appropriated by the Board for the work required by the Agreement, the Agreement shall be terminated. However, such termination shall not relieve the parties of liability for any obligation previously incurred.

V. COMPENSATION AND PAYMENT

A. As compensation for the satisfactory performance of the services required by this Agreement, City shall pay and reimburse Consultant at the rates set forth in Exhibit B.

B. The maximum payable under this Agreement, including reimbursable expenses (see Exhibit B), shall be Four Million Two Hundred Thousand Dollars (\$4,200,000).

C. Consultant shall submit invoices in quadruplicate to City monthly following the effective date of this Agreement for services performed during the preceding month. Each such invoice shall be signed by the Consultant and shall include the following certification:

"I certify under penalty of perjury that the above bill is just and correct according to the terms of Agreement No. _____ and that payment has not been received. I further certify that I have complied with the provisions of the City's Living Wage Ordinance.

(Consultant's Signature)

D. Consultant must include on the face of each itemized invoice submitted for payment its Business Tax Registration Certificate number, as required at Article VIII of this Agreement. No invoice will be processed for payment by City without this number shown thereon. All invoices shall be approved by the Executive Director or his or her designee prior to payment. All invoices due and payable and found to be in order shall be paid as soon as, in the ordinary course of City business, the same may be approved, audited and paid.

Consultant shall submit appropriate supporting documents with each invoice. Such documents may include provider invoices, payrolls, and time sheets. The City may require, and Consultant shall provide, all documents reasonably required to determine whether amounts on the invoice are allowable expenses under this Agreement.

Further, where the Consultant employs Subconsultants under this Agreement, the Consultant shall submit to City, with each monthly invoice, a Monthly Subconsultant Monitoring Report Form (Exhibit C) listing SBE/VSBE/MBE/WBE/DVBE/OBE amounts. Consultant shall provide an explanation for any item that does not meet or exceed the anticipated participation levels for this Agreement, with specific plans and recommendations for improved Subconsultant utilization. Invoices will not be paid without a completed Monthly Subconsultant Monitoring Report Form. All invoices are subject to audit. Consultant is not required to submit support for direct costs items of \$25 or less.

E. For payment and processing, all invoices should be mailed to the following address:

Accounts Payable Section
Harbor Department, City of Los Angeles
P.O. Box 191
San Pedro, CA 90733-0191

VI. RECORDKEEPING AND AUDIT RIGHTS

A. Consultant shall keep and maintain full, complete and accurate books of accounts and records of the services performed under this Agreement in accordance with generally accepted accounting principles consistently applied, which books and records shall be readily accessible to and open for inspection and copying at the premises by City, its auditors or other authorized representatives. Notwithstanding any other provision of this Agreement, failure to do so shall constitute a conclusive waiver of any right to compensation for such services as are otherwise compensable hereunder. Such books and records shall be maintained by Consultant for a period of three (3) years after completion of services to be performed under this Agreement or until all disputes, appeals, litigation or claims arising from this Agreement have been resolved.

B. During the term of this Agreement, City may audit, review and copy any and all writings (as that term is defined in Section 250 of the California Evidence Code) of Consultant and Subconsultants arising from or related to this Agreement or performance of the Scope of Work, whether such writings are (a) in final form or not, (b) prepared by Consultant, Subconsultants or any individual or entity acting for or on behalf of Consultant or a Subconsultant, and (c) without regard to whether such writings have previously been provided to City. Consultant shall be responsible for obtaining access to and providing writings of Subconsultants. Consultant shall provide City at Consultant's sole cost and expense a copy of all such writings within fourteen (14) calendar days of a written request by City. City's right shall also include inspection at reasonable times of the Consultant's office or facilities which are engaged in the performance of the Scope of Work. Consultant shall, at no cost to City, furnish reasonable facilities and assistance for such review and audit. Consultant's failure to comply with this Article VI shall constitute a material breach of this Agreement and shall

entitle City to withhold any payment due under this Agreement until such breach is cured.

VII. INDEPENDENT CONTRACTOR

Consultant, in the performance of the work required by this Agreement, is an independent contractor and not an agent or employee of City. Consultant shall not represent itself as an agent or employee of the City and shall have no power to bind the City in contract or otherwise.

VIII. BUSINESS TAX REGISTRATION CERTIFICATE

The City of Los Angeles Office of Finance requires the implementation and enforcement of Los Angeles Municipal Code Section 21.09 et seq. This Code Section provides that every person, other than a municipal employee, who engages in any business within the City of Los Angeles, is required to obtain the necessary Business Tax Registration Certificate and pay business taxes. The City Controller has determined that this Code Section applies to consulting firms that are doing work for the Department. See Exhibit D.

IX. INDEMNIFICATION

Except for the sole negligence or willful misconduct of the City, or any of its Boards, Officers, Agents, Employees, Assigns and Successors in Interest, Consultant undertakes and agrees to defend, indemnify and hold harmless the City and any of its Boards, Officers, Agents, Employees, Assigns, and Successors in Interest from and against all suits and causes of action, claims, losses, demands and expenses, including, but not limited to, attorney's fees (both in house and outside counsel) and cost of litigation (including all actual litigation costs incurred by the City, including but not limited to, costs of experts and consultants), damages or liability of any nature whatsoever, for death or injury to any person, including Consultant's employees and agents, or damage or destruction of any property of either party hereto or of third parties, arising in any manner by reason of the negligent acts, errors, omissions or willful misconduct incident to the performance of this Agreement by Consultant or its subcontractors of any tier. Rights and remedies available to the City under this provision are cumulative of those provided for elsewhere in this Agreement and those allowed under the laws of the United States, the State of California, and the City.

X. INSURANCE

- A. In addition to and not as a substitute for, or limitation of, any of the indemnity obligations imposed by Article IX, Consultant shall procure and maintain at its sole cost and expense and keep in force at all times during the term of this Agreement the following insurance:

(1) Commercial General Liability Insurance

Commercial general liability insurance covering personal and advertising injury, bodily injury, and property damage providing contractual liability, independent contractors, products and completed operations, and premises/operations coverage written by an insurance company authorized to do business in the State of California rated VII, A- or better in Best's Insurance Guide (or an alternate guide acceptable to City if Best's is not available) within Consultant's normal limits of liability but not less than Five Million Dollars (\$5,000,000.00) combined single limit for injury or claim. Where Consultant provides or dispenses alcoholic beverages, Host Liquor Liability coverage shall be provided as above. Where Consultant provides pyrotechnics, Pyrotechnics Liability shall be provided as above. Said limits shall provide first dollar coverage except that Executive Director may permit a self-insured retention or self-insurance in those cases where, in his or her judgment, such retention or self-insurance is justified by the net worth of Consultant. The retention or self-insurance provided shall provide that any other insurance maintained by the Harbor Department shall be excess of Consultant's insurance and shall not contribute to it. In all cases, regardless of any deductible or retention, said insurance shall contain a defense of suits provision and a severability of interest clause. Each policy shall name the City of Los Angeles Harbor Department, its officers, agents and employees as Primary additional insureds.

(2) Automobile Liability Insurance

Automobile liability insurance written by an insurance company authorized to do business in the State of California rated VII, A- or better in Best's Insurance Guide (or an alternate guide acceptable to City if Best's is not available) within Consultant's normal limits of liability but not less than One Million Dollars (\$1,000,000.00) covering damages, injuries or death resulting from each accident or claim arising out of any one claim or accident. Said insurance shall protect against claims arising from actions or operations of the insured, or by its employees. Coverage shall contain a defense of suits provision and a severability of interest clause. Each policy shall name the City of Los Angeles Harbor Department, its officers, agents and employees as Primary additional insureds.

(3) Workers' Compensation and Employer's Liability

Consultant shall certify that it is aware of the provisions of Section 3700 of the California Labor code which requires every employer to be insured against liability for Workers' Compensation or to undertake self-insurance in accordance with the provisions of that Code, and that Consultant shall comply with such provisions before commencing the performance of the tasks under this Agreement. Coverage for claims under U.S. Longshore and Harbor Workers' Compensation Act, if required under applicable law, shall be included.

Consultant shall submit Workers' Compensation policies whether underwritten by the state insurance fund or private carrier, which provide that the public or private carrier waives its right of subrogation against the City in any circumstance in which it is alleged that actions or omissions of the City contributed to the accident. Such Worker's Compensation and occupational disease requirements shall include coverage for all employees of Consultant, and for all employees of any subcontractor or other vendor retained by Consultant.

(4) Ocean Marine Liability

Consultant shall procure and maintain insurance against claims for injuries to persons or damages to property which may arise from or in connections with Consultant's operations. The cost of the insurance shall be borne by Consultant. The coverage shall be written by an insurance company authorized to do business in the State of California rated VII, A- or better in Best's Insurance Guide (or an alternate guide acceptable to City if Best's Rating is not available). Coverage shall include, but not be limited to:

- (i) Hull and machinery coverage up to the value of the vessel(s);
- (ii) Protection and Indemnity coverage with combined single limits of Five Million Dollars (\$5,000,000.00) per occurrence for bodily injury, illness, death, loss of or damage to the property of another, and Jones Act risks or equivalent thereto internationally.

Coverage shall contain a defense of suits provision and a severability of interest clause. Each policy shall also contain an additional insured endorsement (CG 2010 or equivalent) naming the City of Los Angeles Harbor Department, its officers, agents, and employees as Primary additional insureds, a 10-days notice of cancellation for nonpayment of premium, and a 30-days notice of cancellation for any other reasons.

B. Insurance Procured by Consultant on Behalf of City

In addition to and not as a substitute for, or limitation of, any of the indemnity obligations imposed by Article IX, and where Consultant is required to name the City of Los Angeles Harbor Department, its officers, agents and employees as Primary additional insureds on any insurance policy required by this Agreement, Consultant shall cause City to be named as an additional insured on all policies it procures in connection with this Article X. Consultant shall cause such additional insured status to be reflected in the original policy or by additional insured endorsement (CG 2010 or equivalent) substantially as follows:

"Notwithstanding any inconsistent statement in the policy to which this endorsement is attached, or any endorsement or certificate now or hereafter attached hereto, it is agreed that City, Board, their officers, agents and employees, are additional insureds hereunder, and that coverage is provided for all contractual obligations, operations, uses, occupations, acts and activities of the insured under Agreement No. ____, and under any amendments, modifications, extensions or renewals of said Agreement regardless of where such contractual obligations, operations, uses, occupations, acts and activities occur.

"The policy to which this endorsement is attached shall provide a 10-days notice of cancellation for nonpayment of premium, and a 30-days notice of cancellation for any other reasons to the Risk Manager.

"The coverage provided by the policy to which this endorsement is attached is primary coverage and any other insurance carried by City is excess coverage;

"In the event of one of the named insured's incurring liability to any other of the named insureds, this policy shall provide protection for each named insured against whom claim is or may be made, including claims by other named insureds, in the same manner as if separate policies had been issued to each named insured. Nothing contained herein shall operate to increase the company's limit of liability; and

"Notice of occurrences or claims under the policy shall be made to the Risk Manager of City's Harbor Department with copies to the City Attorney's Office."

C. Required Features of Coverages

Insurance procured by Consultant in connection with this Article X shall include the following features:

(1) Acceptable Evidence and Approval of Insurance

Electronic submission is the required method of submitting Consultant's insurance documents. Consultant's insurance broker or agent shall register with the City's online insurance compliance system **Track4LA**™ at <http://track4la.lacity.org/> and submit the appropriate proof of insurance on Consultant's behalf.

Upon request by City, Consultant shall furnish full copies of certified policies of any insurance policy required herein. This obligation is intended to, and shall, survive the expiration or earlier termination of this Agreement.

(2) Carrier Requirements

All insurance which Consultant is required to provide pursuant to this Agreement shall be placed with insurance carriers authorized to do business in

the State of California and which are rated A-, VII or better in Best's Insurance Guide. Carriers without a Best's rating shall meet comparable standards in another rating service acceptable to City.

(3) Notice of Cancellation

Each insurance policy described above shall provide that it shall not be canceled or reduced in coverage until after the Board of Harbor Commissioners, Attention: Risk Manager and the City Attorney of City have each been given a 10-days notice of cancellation for nonpayment of premium and a 30-days notice of cancellation for any other reason by written notice by registered mail addressed to 425 S. Palos Verdes Street, San Pedro, California 90731.

(4) Modification of Coverage

Executive Director, at his or her sole reasonable discretion, based upon recommendation of independent insurance consultants to City, may increase or decrease amounts and types of insurance coverage required hereunder at any time during the term hereof by giving ninety (90) days' prior written notice to Consultant.

(5) Renewal of Policies

At least thirty (30) days prior to the expiration of any policy required by this Agreement, Consultant shall renew or extend such policy in accordance with the requirements of this Agreement and direct their insurance broker or agent to submit to the City's online insurance compliance system **Track4LA™** at <http://track4la.lacity.org/> a renewal endorsement or renewal certificate or, if new insurance has been obtained, evidence of insurance as specified above. If Consultant neglects or fails to secure or maintain the insurance required above, Executive Director may, at his or her own option but without any obligation, obtain such insurance to protect City's interests. The cost of such insurance shall be deducted from the next payment due Consultant.

(6) Limits of Coverage

If Consultant maintains higher limits than the minimums required by this Agreement, City requires and shall be entitled to coverage for the higher limits maintained by Consultant. Any available insurance proceeds in excess of the specified minimum limits of insurance and coverage shall be available to City.

D. Right to Self-Insure

Upon written approval by the Executive Director, Consultant may self-insure if the following conditions are met:

1. Consultant has a formal self-insurance program in place prior to execution of this Agreement. If a corporation, Consultant must have a formal resolution of its board of directors authorizing self-insurance.
2. Consultant agrees to protect the City, its boards, officers, agents and employees at the same level as would be provided by full insurance with respect to types of coverage and minimum limits of liability required by this Agreement.
3. Consultant agrees to defend the City, its boards, officers, agents and employees in any lawsuit that would otherwise be defended by an insurance carrier.
4. Consultant agrees that any insurance carried by Department is excess of Consultant's self-insurance and will not contribute to it.
5. Consultant provides the name and address of its claims administrator.
6. Consultant submits its most recently filed 10-Q and its 10-K or audited annual financial statements for the three most recent fiscal years prior to Executive Director's consideration of approval of self-insurance and annually thereafter.
7. Consultant agrees to inform Department in writing immediately of any change in its status or policy which would materially affect the protection afforded Department by this self-insurance.
8. Consultant has complied with all laws pertaining to self-insurance.

E. Accident Reports

Consultant shall report in writing to Executive Director within fifteen (15) calendar days after it, its officers or managing agents have knowledge of any accident or occurrence involving death of or injury to any person or persons, or damage in excess of Five Hundred Dollars (\$500.00) to property, occurring upon the premises, or elsewhere within the Port of Los Angeles if Consultant's officers, agents or employees are involved in such an accident or occurrence. Such report shall contain to the extent available (1) the name and address of the persons involved, (2) a general statement as to the nature and extent of injury or damage, (3) the date and hour of occurrence, (4) the names and addresses of known witnesses, and (5) such other information as may be known to Consultant, its officers or managing agents.

XI. TERMINATION PROVISION

The Board of Harbor Commissioners, in its sole discretion, shall have the right to terminate and cancel all or any part of this Agreement for any reason upon giving the Consultant ten (10) days' advance, written notice of the Board's election to cancel and terminate this Agreement. It is agreed that any Agreement entered into shall not limit the right of the City to hire additional consultants or perform the services described in this Agreement either during or after the term of this Agreement.

XII. PERSONAL SERVICE AGREEMENT

A. During the term hereof, Consultant agrees that it will not enter into other contracts or perform any work without the written permission of the Executive Director where the work may conflict with the interests of the Department.

B. Consultant acknowledges that it has been selected to perform the Scope of Work because of its experience, qualifications and expertise. Any assignment or other transfer of this Agreement or any part hereof shall be void provided, however, that Consultant may permit Subconsultant(s) to perform portions of the Scope of Work in accordance with Article I. All Subconsultants whom Consultant utilizes, however, shall be deemed to be its agents. Subconsultants' performance of the Scope of Work shall not be deemed to release Consultant from its obligations under this Agreement or to impose any obligation on the City to such Subconsultant(s) or give the Subconsultant(s) any rights against the City.

XIII. AFFIRMATIVE ACTION

The Consultant, during the performance of this Agreement, shall not discriminate in its employment practices against any employee or applicant for employment because of employee's or applicant's race, religion, national origin, ancestry, sex, age, sexual orientation, disability, marital status, domestic partner status, or medical condition. The provisions of Section 10.8.4 of the Los Angeles Administrative Code shall be incorporated and made a part of this Agreement. All subcontracts awarded shall contain a like nondiscrimination provision. See Exhibit E.

XIV. SMALL/VERY SMALL BUSINESS ENTERPRISE PROGRAM AND LOCAL BUSINESS PREFERENCE PROGRAM

It is the policy of the Department to provide Small Business Enterprises (SBE), Very Small Business Enterprises (VSBE) and Minority-Owned, Women-Owned, Disabled Veteran Business Enterprises and all Other Business Enterprises (MBE/WBE/DVBE/OBE) an equal opportunity to participate in the performance of all City contracts in all areas where such contracts afford such participation opportunities. Consultant shall assist the City in implementing this policy and shall use its best efforts to afford the opportunity for SBEs, VSBEs, MBEs, WBEs, DVBEs, and OBEs to achieve participation in subcontracts where such participation opportunities present themselves

and attempt to ensure that all available business enterprises, including SBEs, VSBEs, MBEs, WBEs, DVBEs, and OBEs, have equal participation opportunity which might be presented under this Agreement. See Exhibit F.

It is also the policy of the Department to support an increase in local and regional jobs. The Department's Local Business Preference Program aims to benefit the Southern California region by increasing jobs and expenditures within the local and regional private sector. Consultant shall assist the City in implementing this policy and shall use its best efforts to afford the opportunity for Local Business Enterprises to achieve participation in subcontracts where such participation opportunities present themselves.

NOTE: Prior to being awarded a contract with the City, Consultant and all Subconsultants must be registered on the City's Contracts Management and Opportunities Database, Los Angeles Business Assistance Virtual Network (LABAVN), at <http://www.labavn.org>.

XV. CONFLICT OF INTEREST

It is hereby understood and agreed that the parties to this Agreement have read and are aware of the provisions of Section 1090 et seq. and Section 87100 et seq. of the California Government Code relating to conflict of interest of public officers and employees, as well as the Los Angeles Municipal Code (LAMC) Municipal Ethics and Conflict of Interest provisions of Section 49.5.1 et seq. and the Conflict of Interest Codes of the City and the Department. All parties hereto agree that they are unaware of any financial or economic interest of any public officer or employee of City relating to this Agreement. Notwithstanding any other provision of this Agreement, it is further understood and agreed that if such financial interest does exist at the inception of this Agreement, City may immediately terminate this Agreement by giving written notice thereof.

During the term of this Agreement, Consultant shall inform the Department in writing when Consultant, or any of its Subconsultants, employs or hires in any capacity, and for any length of time, a person who has worked for the Department as a Commissioner, officer or employee. Said notice shall include the individual's name and current position and their prior position and years of employment with the Department. Written notice shall be provided by Consultant to the Department within thirty (30) days of the employment or hiring of the individual.

XVI. COMPLIANCE WITH APPLICABLE LAWS

Consultant shall at all times in the performance of its obligations comply with all applicable laws, statutes, ordinances, rules and regulations, and with the reasonable requests and directions of Executive Director.

XVII. GOVERNING LAW / VENUE

This Agreement shall be governed by and construed in accordance with the laws of the State of California, without reference to the conflicts of law, rules and principles of such State. The parties agree that all actions or proceedings arising in connection with this Agreement shall be tried and litigated exclusively in the State or Federal courts located in the County of Los Angeles, State of California, in the judicial district required by court rules.

XVIII. TRADEMARKS, COPYRIGHTS, AND PATENTS

Consultant agrees to save, keep, hold harmless, protect and indemnify the City and any of its officers or agents from any damages, cost, or expenses in law or equity from infringement of any patent, trademark, service mark or copyright of any person or persons, or corporations in consequence of the use by City of any materials supplied by Consultant in the performance of this Agreement.

XIX. PROPRIETARY INFORMATION

A. Writings, as that term is defined in Section 250 of the California Evidence Code (including, without limitation, drawings, specifications, estimates, reports, records, reference material, data, charts, documents, renderings, computations, computer tapes or disks, submittals and other items of any type whatsoever, whether in the form of writing, figures or delineations), which are obtained, generated, compiled or derived in connection with this Agreement (collectively hereafter referred to as "property"), are owned by City as soon as they are developed, whether in draft or final form. City has the right to use or permit the use of property and any ideas or methods represented by such property for any purpose and at any time without compensation other than that provided in this Agreement. Consultant hereby warrants and represents that City at all times owns rights provided for in this section free and clear of all third-party claims whether presently existing or arising in the future, whether or not presently known. Consultant need not obtain for City the right to use any idea, design, method, material, equipment or other matter which is the subject of a valid patent, unless such patent is owned by Consultant or one of its employees, or its Subconsultant or the Subconsultant's employees, in which case such right shall be obtained without additional compensation. Whether or not Consultant's initial proposal or proposals made during this Agreement are accepted by City, it is agreed that all information of any nature whatsoever connected with the Scope of Work, regardless of the form of communication, which has been or may be given by Consultant, its Subconsultants or on either's behalf, whether prior or subsequent to this Agreement becoming effective, to the City, its boards, officers, agents or employees, is not given in confidence. Accordingly, City or its designees may use or disclose such information without liability of any kind, except as may arise under valid patents.

B. If research or development is furnished in connection with this Agreement and if, in the course of such research or development, patentable work product is produced by Consultant, its officers, agents, employees, or Subconsultants, the City

shall have, without cost or expense to it, an irrevocable, non-exclusive royalty-free license to make and use, itself or by anyone on its behalf, such work product in connection with any activity now or hereafter engaged in or permitted by City. Upon City's request, Consultant, at its sole cost and expense, shall promptly furnish or obtain from the appropriate person a form of license satisfactory to the City. It is expressly understood and agreed that, as between City and Consultant, the referenced license shall arise for City's benefit immediately upon the production of the work product, and is not dependent on the written license specified above. City may transfer such license to its successors in the operation or ownership of any real or personal property now or hereafter owned or operated by City.

XX. CONFIDENTIALITY

The data, documents, reports, or other materials which contain information relating to the review, documentation, analysis and evaluation of the work described in this Agreement and any recommendations made by Consultant relative thereto shall be considered confidential and shall not be reproduced, altered, used or disseminated by Consultant or its employees or agents in any manner except and only to the extent necessary in the performance of the work under this Agreement. In addition, Consultant is required to safeguard such information from access by unauthorized personnel.

XXI. NOTICES

In all cases where written notice is to be given under this Agreement, service shall be deemed sufficient if said notice is deposited in the United States mail, postage prepaid. When so given, such notice shall be effective from the date of mailing of the same. For the purposes hereof, unless otherwise provided by notice in writing from the respective parties, notice to the Department shall be addressed to Director of Construction & Maintenance, Los Angeles Harbor Department, P.O. Box 151, San Pedro, California 90733-0151, and notice to Consultant shall be addressed to it at the address set forth above. Nothing herein contained shall preclude or render inoperative service of such notice in the manner provided by law.

XXII. TAXPAYER IDENTIFICATION NUMBER (TIN)

The Internal Revenue Service (IRS) requires that all consultants and suppliers of materials and supplies provide a TIN to the party that pays them. Consultant declares that it has an authorized TIN which shall be provided to the Department prior to payment under this Agreement. No payments will be made under this Agreement without a valid TIN.

XXIII. SERVICE CONTRACTOR WORKER RETENTION POLICY AND LIVING WAGE POLICY REQUIREMENTS

The Board of Harbor Commissioners of the City of Los Angeles adopted Resolution No. 5771 on January 13, 1999, agreeing to adopt the provisions of Los Angeles City Ordinance No. 171004 relating to Service Contractor Worker

Retention (SCWR), Section 10.36 et seq. of the Los Angeles Administrative Code, as the policy of the Department. Further, Charter Section 378 requires compliance with the City's Living Wage requirements as set forth by ordinance, Section 10.37 et seq. of the Los Angeles Administrative Code. Consultant shall comply with the policy wherever applicable. Violation of this provision, where applicable, shall entitle the City to terminate this Agreement and otherwise pursue legal remedies that may be available.

XXIV. WAGE AND EARNINGS ASSIGNMENT ORDERS / NOTICES OF ASSIGNMENTS

The Consultant and/or any Subconsultant are obligated to fully comply with all applicable state and federal employment reporting requirements for the Consultant and/or Subconsultant's employees.

The Consultant and/or Subconsultant shall certify that the principal owner(s) are in compliance with any Wage and Earnings Assignment Orders and Notices of Assignments applicable to them personally. The Consultant and/or Subconsultant will fully comply with all lawfully served Wage and Earnings Assignment Orders and Notices of Assignments in accordance with Cal. Family Code Sections 5230 et seq. The Consultant or Subconsultant will maintain such compliance throughout the term of this Agreement.

XXV. EQUAL BENEFITS POLICY

The Board of Harbor Commissioners of the City of Los Angeles adopted Resolution No. 6328 on January 12, 2005, agreeing to adopt the provisions of Los Angeles City Ordinance No. 172,908, as amended, relating to Equal Benefits, Section 10.8.2.1 et seq. of the Los Angeles Administrative Code, as a policy of the Department. Consultant shall comply with the policy wherever applicable. Violation of this policy shall entitle the City to terminate any Agreement with Consultant and pursue any and all other legal remedies that may be available. See Exhibit G.

XXVI. COMPLIANCE WITH LOS ANGELES CITY CHARTER SECTION 470(c)(12)

The Consultant, Subconsultants, and their Principals are obligated to fully comply with City of Los Angeles Charter Section 470(c)(12) and related ordinances, regarding limitations on campaign contributions and fundraising for certain elected City officials or candidates for elected City office if the agreement is valued at \$100,000 or more and requires approval of a City elected official. Additionally, Consultant is required to provide and update certain information to the City as specified by law. Any Consultant subject to Charter Section 470(c)(12), shall include the following notice in any contract with a subconsultant expected to receive at least \$100,000 for performance under this Agreement:

Notice Regarding Los Angeles Campaign Contribution and Fundraising Restrictions

As provided in Charter Section 470(c)(12) and related ordinances, you are a subconsultant on Harbor Department Agreement No. _____. Pursuant to City Charter Section 470(c)(12), subconsultant and its principals are prohibited from making campaign contributions and fundraising for certain elected City officials or candidates for elected City office for 12 months after the Agreement is signed. Subconsultant is required to provide to Consultant names and addresses of the subconsultant's principals and contact information and shall update that information if it changes during the 12 month time period. Subconsultant's information must be provided to Consultant within 10 business days. Failure to comply may result in termination of the Agreement or any other available legal remedies including fines. Information about the restrictions may be found at the City Ethics Commission's website at <http://ethics.lacity.org/> or by calling 213-978-1960.

Consultant, Subconsultants, and their Principals shall comply with these requirements and limitations. Violation of this provision shall entitle the City to terminate this Agreement and pursue any and all legal remedies that may be available.

XXVII. STATE TIDELANDS GRANTS

This Agreement is entered into in furtherance of and as a benefit to the State Tidelands Grant and the trust created thereby. Therefore, this Agreement is at all times subject to the limitations, conditions, restrictions and reservations contained in and prescribed by the Act of the Legislature of the State of California entitled "An Act Granting to the City of Los Angeles the Tidelands and Submerged Lands of the State Within the Boundaries of Said City," approved June 3, 1929 (Stats. 1929, Ch. 651), as amended, and provisions of Article VI of the Charter of the City of Los Angeles relating to such lands. Consultant agrees that any interpretation of this Agreement and the terms contained herein must be consistent with such limitations, conditions, restrictions and reservations.

XXVIII. INTEGRATION

This Agreement contains the entire understanding and agreement between the parties hereto with respect to the matters referred to herein. No other representations, covenants, undertakings, or prior or contemporaneous agreements, oral or written, regarding such matters which are not specifically contained, referenced, and/or incorporated into this Agreement by reference shall be deemed in any way to exist or bind any of the parties. Each party acknowledges that it has not been induced to enter into the Agreement and has not executed the Agreement in reliance upon any promises, representations, warranties or statements not contained, referenced, and/or incorporated into the Agreement. **THE PARTIES ACKNOWLEDGE THAT THIS AGREEMENT IS INTENDED TO BE, AND IS, AN INTEGRATED AGREEMENT.**

XXIX. SEVERABILITY

Should any part, term, condition or provision of this Agreement be declared or determined by any court of competent jurisdiction to be invalid, illegal or incapable of being enforced by any rule of law, public policy, or city charter, the validity of the remaining parts, terms, conditions or provisions of this Agreement shall not be affected thereby, and such invalid, illegal or unenforceable part, term, condition or provision shall be treated as follows: (a) if such part, term, condition or provision is immaterial to this Agreement, then such part, term, condition or provision shall be deemed not to be a part of this Agreement; or (b) if such part, term, condition or provision is material to this Agreement, then the parties shall revise the part, term, condition or provision so as to comply with the applicable law or public policy and to effect the original intent of the parties as closely as possible.

XXX. CONSTRUCTION OF AGREEMENT

This Agreement shall not be construed against the party preparing the same, shall be construed without regard to the identity of the person who drafted such and shall be construed as if all parties had jointly prepared this Agreement and it shall be deemed their joint work product; each and every provision of this Agreement shall be construed as though all of the parties hereto participated equally in the drafting hereof; and any uncertainty or ambiguity shall not be interpreted against any one party. As a result of the foregoing, any rule of construction that a document is to be construed against the drafting party shall not be applicable.

XXXI. TITLES AND CAPTIONS

The parties have inserted the Article titles in this Agreement only as a matter of convenience and for reference, and the Article titles in no way define, limit, extend or describe the scope of this Agreement or the intent of the parties in including any particular provision in this Agreement.

XXXII. MODIFICATION IN WRITING

This Agreement may be modified only by written agreement of all parties. Any such modifications are subject to all applicable approval processes required by, without limitation, City's Charter and City's Administrative Code.

XXXIII. WAIVER

A failure of any party to this Agreement to enforce the Agreement upon a breach or default shall not waive the breach or default or any other breach or default. All waivers shall be in writing.

XXXIV. EXHIBITS; ARTICLES

All exhibits to which reference is made in this Agreement are deemed incorporated in this Agreement, whether or not actually attached. To the extent the terms of an exhibit conflict with or appear to conflict with the terms of the body of the Agreement, the terms of the body of the Agreement shall control. References to Articles are to Articles of this Agreement unless stated otherwise.

XXXV. COUNTERPARTS

This Agreement may be executed in any number of counterparts, each of which shall be deemed an original and all of which shall constitute together one and the same instrument.

////

////

////

////

IN WITNESS WHEREOF, the parties hereto have executed this Agreement on the date to the left of their signatures.

THE CITY OF LOS ANGELES, by its Board of Harbor Commissioners

Dated: _____, 2017

By: _____
EUGENE D. SEROKA
Executive Director

Attest: _____
AMBER M. KLESGES
Board Secretary

AMERICAN MARINE CORPORATION

Dated: August 24, 2017

By: _____
ROBERT SHANAZARIAN PRESIDENT
(Print/type name and title)

Attest: _____
Michael Dunn DNR OPS MGR
(Print/type name and title)

APPROVED AS TO FORM AND LEGALITY

August 30, 2017
MICHAEL N. FEUER, City Attorney
JANNA B. SIDLEY, General Counsel

By: _____
JOHN T. DRISCOLL, Deputy

JTD:jpr
Attachments

Account #	<u>54040</u>	W.O. #	<u>VARIOUS</u>
Ctr/Div #	<u>0510</u>	Job Fac. #	<u>VARIOUS</u>
Proj/Prog	<u>000</u>		
Budget FY:		Amount:	
	<u>2018</u>		<u>\$ 800,000</u>
	<u>2019</u>		<u>\$ 1,400,000</u>
	<u>2020</u>		<u>\$ 1,500,000</u>
	<u>TOTAL: 2021</u>		<u>\$ 500,000</u>
	<u>TOTAL</u>		<u>\$ 4,200,000</u>
For Acct/Budget Div. Use Only:			
Verified by:	_____		
Verified Funds Available:	_____		
Date Approved:	<u>8/28/17</u>		

EXHIBIT A

Scope of Work

The scope of this project includes wharf inspection and repair (approximately 200-300 piles are wrapped annually per Attachment 1), damage surveys, slope/seawall inspection and repair, and underwater vessel maintenance and inspection. All wrapping materials will be provided by the Harbor Department.

1. The following requirements encompass the scope of work to be provided by the contractor(s):

Two (2) primary hard hat dive teams, fully equipped, each consisting of one (1) skilled hard hat diver, one (1) tender and one (1) standby diver, one of which will serve as the designated person in charge, available Monday through Friday on an eight (8) hour shift. Please note that the dive team will be expected to provide services on an emergency call-out basis, as required. Equipment shall include, but not be limited to, a dive boat, a work punt or float, and hand equipment enumerated in Section 2.A below.

Estimated annual usage is as follows:

Primary Team(s) – Diving Days	220 days (each team)
Overtime	20 hours (each team)
Saturday/Sunday	8 days (each team)
Holidays	2 days (each team)

NOTE: With regard to estimated annual usage, this is the basis for the evaluation of the proposals and represents an estimate as to the frequency that services will be required. The Harbor Department does not guarantee that these figures will be met or that they may not be exceeded and makes no guarantee as to the accuracy or reliability of these figures.

2. The following are possible additional services which may be requested:
 - A. One (1) as-needed hard hat dive team, fully equipped, consisting of one (1) skilled hard hat diver, one (1) tender and one (1) standby diver, one of which will serve as the designated person in charge, available upon forty-eight (48) hours written or oral notice. The estimated annual usage of the as-needed team is 30 diving days. Equipment shall include, but not be limited to, a dive boat, a work punt or float, and hand equipment enumerated below:
 1. Hydraulic saw and power source
 2. Hydraulic drill and power source
 3. Air lift – 8" diameter PVC pipe with 150 linear feet of air supply hose

EXHIBIT A

4. 5,000 lb. lift bags
5. 8" educator with 20" discharge hose (pump by Harbor Department)
6. Hydraulic jack hammer and power source
7. Underwater color digital camera with flash capability
8. Complete digital recording system, with underwater camera, audio, and deck monitor
9. High pressure water blaster equipment (rated at 10,000 PSI) with pump, hoses and power source for hydraulic displacement of marine growth
10. 300 amp welding unit with oxygen and leads
11. Portable generator, rated output 110 volts

3. Contractor(s) shall also provide

A. Underwater services capable of being performed at depths up to seventy-five feet (mean low water – Attachment 2) consisting of:

A1. Heavy timber, concrete, and steel wharf and structural construction and reconstruction;

B. Annual inspection and evaluation of the condition of timber fender and bearing piles, concrete bearing piles and dolphin piles, metal sheet piles, wharf structure, wharf slope rat-proofing, and electrolysis protection systems;

C. Timber wharf maintenance repairs including the installation and replacement of timber jacketing materials (such as plastic wrap) on piles, braces, and structural supports; and stub-pile, barrel, or jacket-pour repairs to bearing piles;

D. Maintenance repairs in conjunction with Harbor Department surface crew including concrete pouring; installation of bolts, braces, and stub piles; and buoy line replacement;

E. Wharf damage inspections/surveys including preparation of written reports documenting all observed conditions;

F. Inspection of new construction for conformance to Harbor Department specifications;

G. Inspection of plastic pile wrapping and seals to ensure proper installation by others and to ensure the integrity fully meets Harbor Department requirements;

EXHIBIT A

- H. Application of underwater coatings, paints, and epoxies;
 - I. Provide labor to fabricate ready-to-use pile wrap, and deliver to sites within the Harbor Department; and
 - J. Other miscellaneous services.
4. Report all information obtained in conducting diving services in a form and manner requested by the Director of Construction and Maintenance. Digital camera pictures will be required to document conditions found on inspections and video recordings will be required to document all underwater work performed.
 5. Perform other construction and diving services as requested by the Director of Construction and Maintenance.

NOTE: A diving day consists of eight (8) hours of underwater hard hat diving or related activity during a working day, or during shift hours when multiple shifts are worked, Monday through Friday. Diving teams should be available on an on-call basis to respond to emergency situations if required. The Director of Construction and Maintenance or an authorized representative must authorize any additional time to extend the work beyond a diver day, including work performed on Saturdays, Sundays or holidays. The Harbor Department will compensate such additional time at the applicable rate agreed upon. This calculation specifically excludes any loss of time due to unavailability of equipment or any other performance failure of contractor. Personnel who report for work in an unfit condition or who are not otherwise qualified to do the work will render the team unsuitable for work.

6. The following equipment must be furnished by the selected contractor:
 - A. Work boats in reliable, seaworthy condition which comply with all applicable state, federal and Coast Guard regulations for licensing and safety, and are not greater than FORTY (40) feet in length and are fully capable of performing all job responsibilities of this contract.
 - B. Hard hat diving suit and accessories (heavy gear-surface supplied commercial diving equipment) to safely perform underwater work at depths up to seventy-five (75) feet (mean Low Low Water).
 - C. Working punt or float not less than TEN (10) feet in length.
 - D. A saltwater pump to effectively clear mud and debris from around pilings for installation of plastic wraps. Pump shall be a minimum of

EXHIBIT A

twelve horsepower and have 150 feet of discharge hose with a nozzle assembly.

- E. Air winch mounted to the dive boat with a minimum of 2,000 lb. pull rating.
- F. The following specialized underwater diving services and/or equipment are as needed. The extent to which additional equipment will be needed is not known.
 - 1. Hydraulic saw and power source
 - 2. Hydraulic drill and power source
 - 3. Air lift — 8" diameter PVC pipe with 150 linear feet of air supply hose
 - 4. 5,000 lb. lift bags
 - 5. 8" educator with 20" discharge hose (pump by Harbor Department)
 - 6. Hydraulic jack hammer and power source
 - 7. Underwater color digital camera with flash capability
 - 8. Complete digital recording system, with underwater camera, audio, and deck monitor
 - 9. High pressure water blaster equipment (rated at 10,000 PSI) with pump, hoses and power source for hydraulic displacement of marine growth
 - 10. 300 amp welding unit with oxygen and leads
 - 11. Portable generator, rated output 110 volts

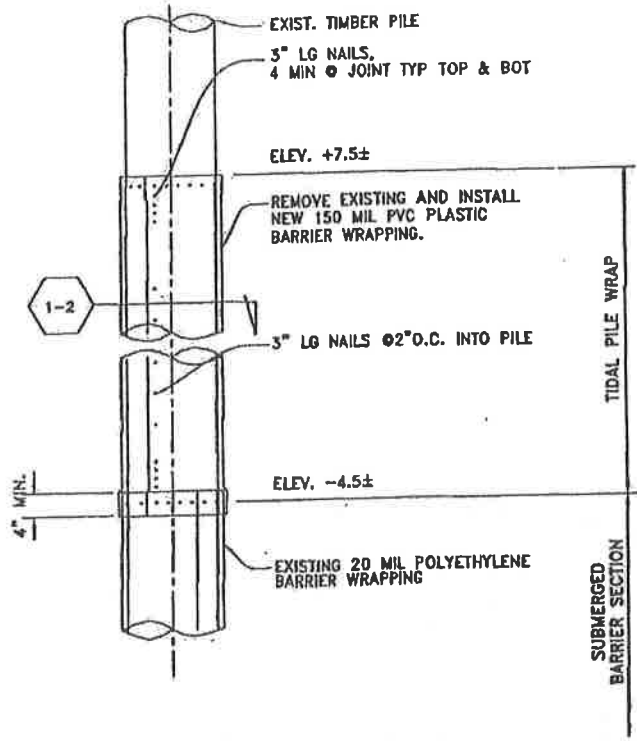

1-1

TIDAL WRAP
ELEVATION - RECONSTRUCTION
OF EXISTING FENDER PILE WRAPPING
NEW FENDER PILE WRAPPING, SIMILAR
SCALE: NTS

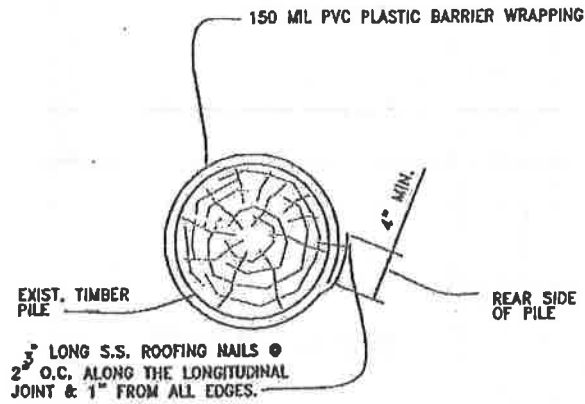

NOTE:

THE WRAPPING SHALL BE UNIFORM & CONTINUOUS THROUGHOUT THE RECONSTRUCTION LENGTH OF PILE RESULTING IN A SMOOTH, WRINKLE FREE, AIRTIGHT FIT.

1-2 SECTION - 150mil PVC PILE WRAP
SCALE: NTS

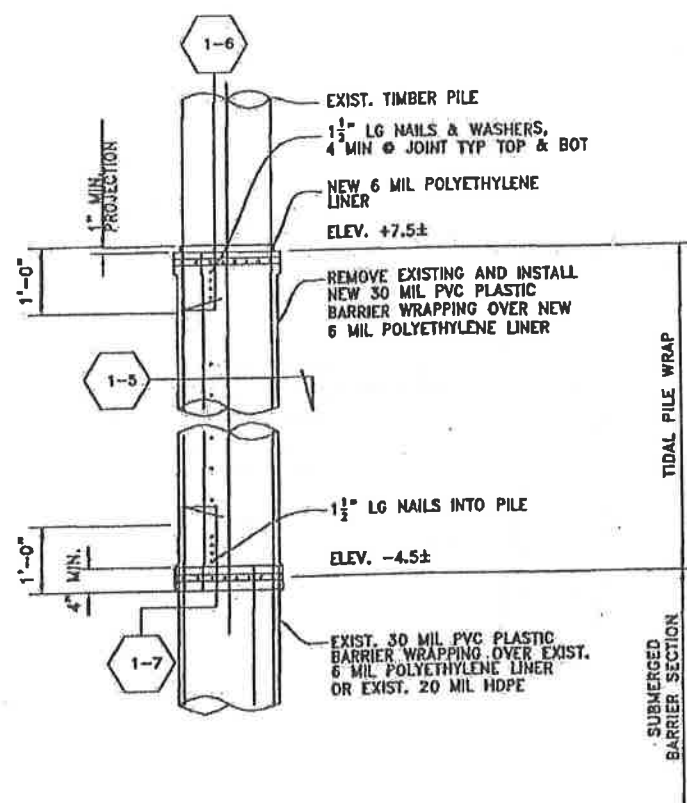

NOTE: DETAILS 1-1 TO 1-6 SHOWN FOR EITHER REPAIR OR REPLACEMENT OF EXIST WRAPPING.

TIDAL WRAP
ELEVATION - RECONSTRUCTION
OF EXISTING PILE WRAPPING
NEW PILE WRAPPING, SIMILAR
1-3
SCALE: NTS

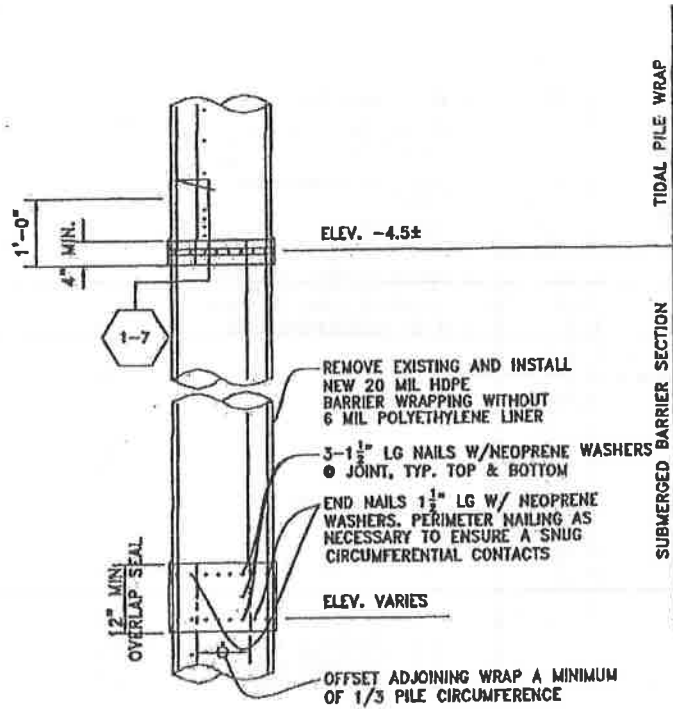

SUBMERGED WRAP
ELEVATION - RECONSTRUCTION
OF EXISTING PILE WRAPPING
NEW PILE WRAPPING, SIMILAR

1-4

SCALE: NTS

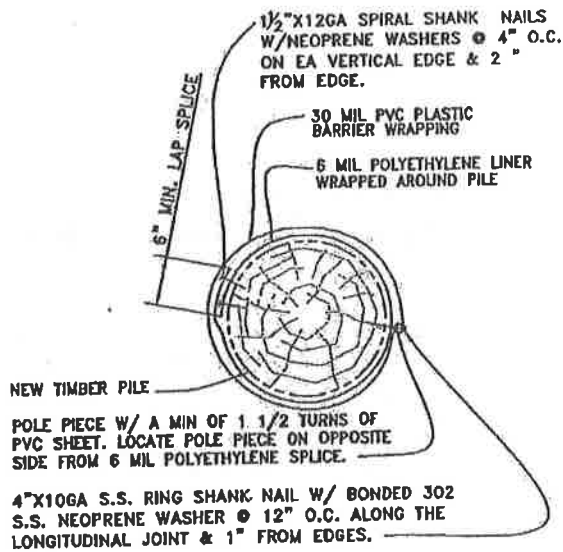

NOTE:

1. PRE-WRAP PILE WITH 6 MIL POLYETHYLENE LINER AS TIGHTLY AS POSSIBLE BEFORE DRIVING PILE.
2. THE WRAPPING SHALL BE UNIFORM & CONTINUOUS THROUGHOUT THE RECONSTRUCTION LENGTH OF PILE RESULTING IN A SMOOTH, WRINKLE FREE, AIRTIGHT FIT.
3. DO NOT EMBED HEAD OF 4" NAIL INTO PLASTIC WRAPPING

1-5 SECTION - 30mil PVC PILE WRAP
SCALE: NTS

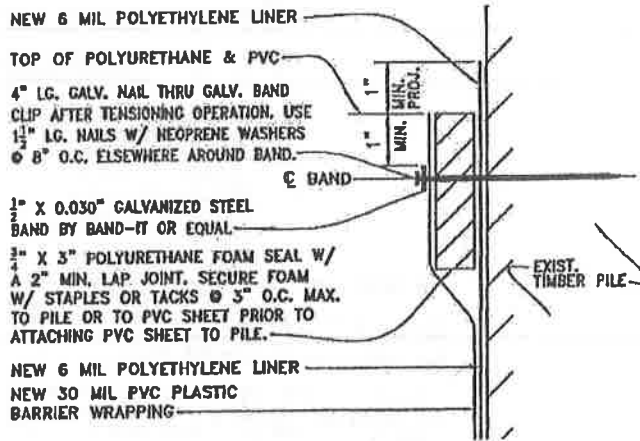

NOTE:

BANDING:
 BANDS SHALL BE INSTALLED USING A "SIGNADE" STRETCHER OR EQUIVALENT TOOL TO PROVIDE ADEQUATE BAND TENSION FOR MAXIMUM COMPRESSION OF FOAM.

SECTION - UPPER BAND
 INTERTIDAL WRAPPING
 1-6
 SCALE: NTS

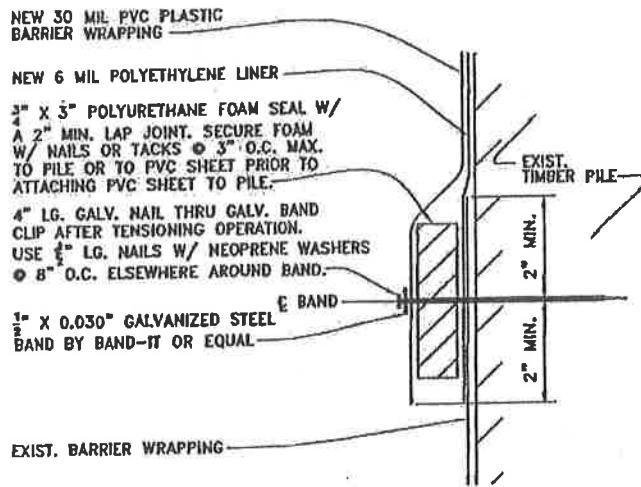

SECTION - LOWER BAND
 INTERTIDAL WRAPPING
 SCALE: NTS

1-7

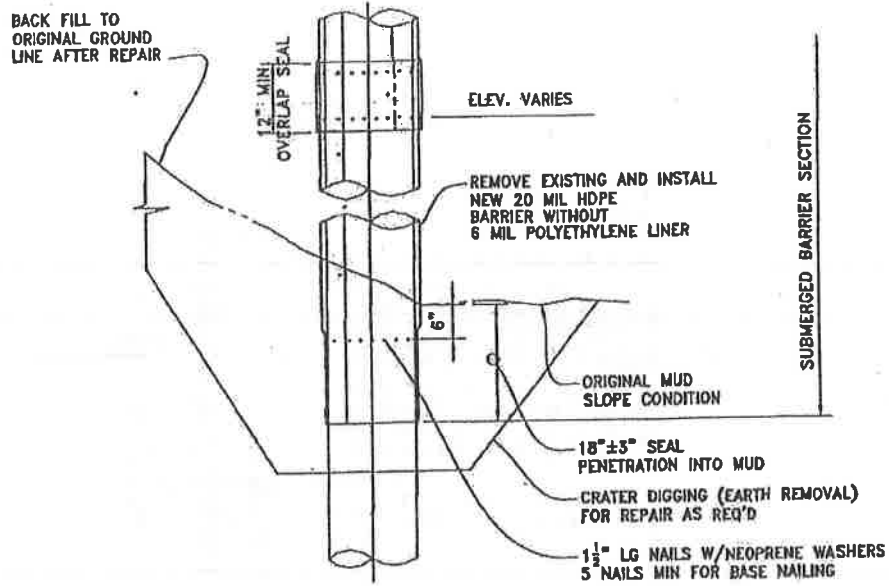

MUD SEAL REPAIR NOTES:

1. CRATER DIGGING SHALL BE DONE MANUALLY.
2. AFTER WRAPPING, BACK FILL CRATER WITH MUD TO ORIGINAL ELEVATION.
3. REMOVE ANY ROCK PRIOR TO PILE WRAPPING.

ROCKLINE WRAP
ELEVATION - RECONSTRUCTION
OF EXISTING PILE WRAPPING
NEW PILE WRAPPING, SIMILAR

1-8

SCALE: NTS

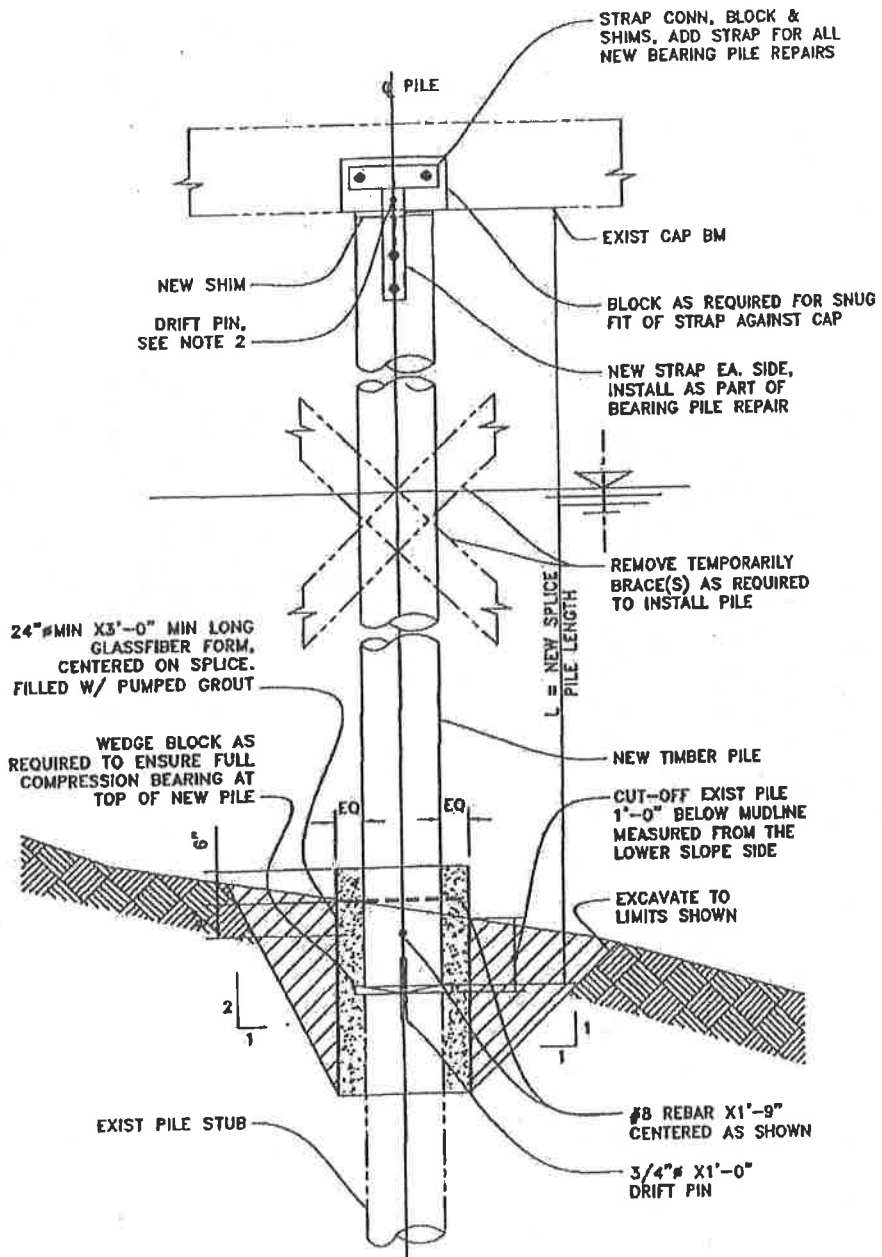

NOTE:

1. ALL NEW BEARING PILES SHALL BE WRAPPED PER 1-5 TO 1-8.
2. DRIFT PINS MAY BE ENCOUNTERED. REMOVE PIN WHERE OCCURS.

Attachment 2

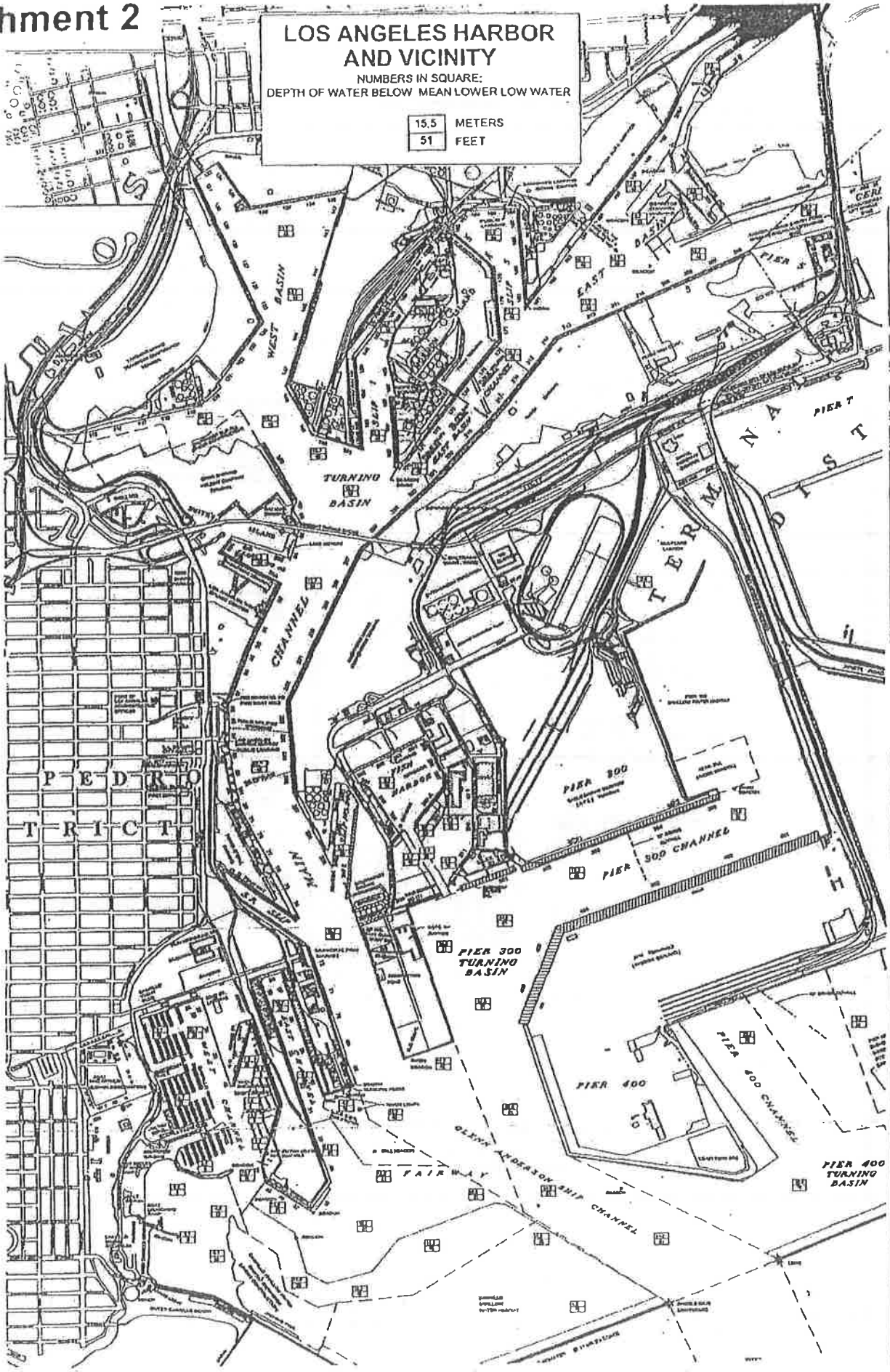

EXHIBIT B
COMPENSATION



An American Marine Services Group Company

Daily Cost for Diving Services (Equipment and Tool Included)

Regular Hours

Note: Per California Labor Law and Prevailing Wage guidelines, when diving operations occur and the diver descends below the surface, an 8-hour minimum will apply.

Each **Primary Dive Team** (3man: Diver, St.By Diver/Tender, Asst. Tender), Dive Vessel, Diving Equipment, Punt, Equipment and Tools (listed below):

Per 8-hour regular day straight time shift pre dive team (Monday-Friday) \$ 2,890

As Needed Dive Team (3man: Diver, St.By Diver/Tender, Asst. Tender), Dive Vessel, Diving Equipment, Punt, Equipment and Tools (listed below):

Per 8-hour regular day straight time shift pre dive team (Monday-Friday) \$ 2,890

Per hour for less than 8-hour shift (Rate applies for *non-diving operations only*;
minimum 2-hour show up pay required) Per hour/Per Team (3-man team) \$ 280

Overtime/Weekend/Holiday

Primary Dive Team or As Needed Dive Team

Per overtime hour (greater than 8 hours; Monday-Friday) \$ 542

Per 8-hour overtime day (Saturday) \$ 4,334

Per 8-hour double time day (Sunday & Holidays) \$ 4,334

Depth Premium – Applies to dives deeper than 49ft.

Price per foot/ per day/per diver \$ 7.50

Included Equipment and Tools on each dive boat - **at no charge**:

Note: All cost presentations reflect labor at current prevailing rates and are in accordance with all California State Labor Law pay scales and labor conditions for Divers and Tenders. As required, each 3 person dive team will consist of a Diver, a Stand-by Diver, and a Tender, with one of the team members being designated as the DPIC.

- Hydraulic power unit, 150 hose; U/W hydraulic chainsaw, spares, blades; U/W hydraulic drill (1/2" chuck, variety of auger bits/sizes); U/W hydraulic chipping/jack hammer
- Air Lift/Eductor 8" dia with 150 ft of air supply hose
- 5,000lbs lift bags (assorted sizes to lift 5,000lbs from sea floor)
- U/W diver operated 8"eductor with 20ft discharge (POLA provided pump)
- U/W digital wide angle camera with flash (professional quality)
- Complete U/W digital video & audio recording system with deck monitor
- Saltwater jet pump (16HP min.) with 150ft of discharge hose
- U/W diver operated hand jet and/or 4"eductor system
- 2,000lbs boat mounted air winch
- 300 Amp welding unit with O2 and leads
- U/W burning gear-200ft system all inclusive (rods reimbursed by POLA)
- Portable generator with 110V output





DISCOUNT

No discount provisions

ANNUAL INCREASE:

In line with the planned Union Labor Wage and Benefit increases during the 3 year term of the contract, a 3% annual increase in all listed prices will apply. Increases will coincide with contract annual renewal timeline.



Pile Wrap Fabrication & Delivery

AMC can provide **prefabricated** wrap packages per RFP drawings and specifications. Similar types of wraps are currently being installed throughout the POLA by AMC divers under the Harbor Diving Contract.

Below items **include** raw materials.

<p><u>Tidal wrap package includes:</u></p> <p>Tidal wraps assembled in various lengths, stapled, rolled and delivered to job site.</p> <p>Price per linear foot of Tidal Wrap: \$10.⁵⁰/ft (Minimum order 1,700 linear ft)</p>	<p>30mil PVC outer material 6mil Polyethylene clear inner liner 3" top and bottom foam seal 1"x 3/4" oak sticks (each side) 1" Aluminum/other band top and bottom 4" and 1 1/2" nails provided in bulk</p>
<p><u>Submerged wrap package includes:</u> (Subwraps, mudline wraps, rockline seal wraps)</p> <p>Submerged wraps assembled in various lengths, stapled, rolled and delivered to job site.</p> <p>Price per linear foot of Submerged Wrap: \$7.⁵⁰/ft (Minimum order 850 linear ft)</p>	<p>30mil PVC/HDPE outer material 1"x 3/4" oak sticks (each side) 4" and 1 1/2" nails provided in bulk.</p>
<p><u>150 mil wrap package includes:</u> (Currently POLA uses 12ft long wraps)</p> <p>150mil wraps assembled rolled and delivered to job site.</p> <p>Price per 12 foot long 150 mil wrap package: \$480.⁰⁰ (Minimum Order 200 units)</p>	<p>12ft long rolled sheet of 150mil HDPE (black with drilled edges) 125- 4"SS nails with washers</p>

If all raw materials are provided/delivered/picked up by the Port, the following costs apply:

<u>Item</u>	<u>Cost/linear foot</u>	<u>Minimum Order</u>
Tidal Wrap	\$5	500ft
Sub Wrap	\$3. ⁵⁰	500ft
150 mil (12ft lengths)	\$4	500ft





A Member of the American Marine Services Group

AMC TERMINAL ISLAND RATE SHEET (Effective January 1, 2017)

Moorage**:

Small Vessel or Derelict Moorage	\$100.00/day
Barge or vessel up to 150' in length:	\$325.00/day
Barge or vessel between 150' and 200' in length:	\$425.00/day
Barge or vessel between 200' and 250' in length:	\$525.00/day
Barge or vessel between 250' and 300' in length	\$625.00/day
Barge or vessel over 300' in length:	\$2.25/ft/day

AMC facility Utilization (as quoted):

Lockable, private office w/ phone & internet, use of AMC main office fax, scanner, copier
Upland storage area: (Square footage as agreed upon)
Use of restrooms and shipping and receiving address.

Labor*:

Laborer-	\$61.00 per straight time hr*
Riggers-	\$71.00 per straight time hr*
Welders & Fabricators-	\$92.00 per straight time hr*
Mechanic/Machinist	\$92.00 per straight time hr*
Supervisor-	\$92.00 per hour

Equipment:

Pick-up Truck w/ driver-	\$95.00/hr plus gas
45 Ton Crane w/ certified operator-	\$370.00/hr. (two hour minimum)
Forklift w/ operator -	\$185.00/hr. (one hour minimum)
1000 HP tugboat -	\$475.00/hr. (two hour minimum) Holiday \$575.00/hr

Misc. Services:

- Line handling will be charged a flat fee of \$200 per docking or undocking;
- Potable Water- \$6.00 per ton plus any labor charge
- Electricity - \$0.25/KWH
- Non-Hazardous Trash bin - \$375/month
- Guard service (required when conducting operations on AMC premises after normal business hours) -
Weeknights: \$600.00 per overnight shift; Week-ends/Holidays: \$1200.00 per day (Not pro-rated)

Outside Services & Materials:

- 15% will be charged on the cost of all work performed by subcontractors and service providers who require transit or access on AMC premises (Charge does not apply to Customer's own employees);
- 15% will be added to the cost of all materials purchased and provided by AMC plus any labor or equipment required to pick up, deliver, offload, or load-out.

Notes:

- *Labor rates are for straight time labor (Mon through Fri 0730-1600); overtime rates are 1.5 times the straight time rate and apply at all other times except holidays. Holidays are double time and are charged at 2 times the hourly rate
- ** Vessel moorage is charged per calendar day or any part of a calendar day.
- All services subject to the terms and conditions of AMC's standard work order agreement

Honolulu 65 N. Nimitz Hwy. Pier 14, Honolulu HI 96817-5021
California 1500 S. Barracuda St., Berth 270/271 L.A., Terminal Island CA 90731-7357
Alaska 6000 "A" Street, Anchorage, AK 99518-1815

Phone (808) 545-5190 Fax (808) 538-1703
Phone (310) 832-3321 Fax (310) 832-4701
Phone (907) 562-5420 Fax (907) 562-5426

VESSEL RATES

<u>Dive Support Vessel</u>	<u>Rate/Hour (fueled with operator)</u>
M/V "Islander" (100'x24')	\$750
M/V "Lokalia" (52'x15')	\$435
M/V "Stephen S" (35'x12')	\$310
M/V "Huki Pau" (24'x8'), "Nautilus" (38'x9') self propelled dive vessels (or equivalent)	\$145
M/V "Tuna" (28'x8') self propelled pontoon dive vessels (or equivalent)	\$105
Work float/skiff, punt (not motorized)	\$ 75/day

Hourly rates based on fuel prices at or below \$4.⁰⁰/gallon. Additional fuel surcharges may apply. Arrangements and pricing for other vessels specific to project demands can be provided upon request.

EQUIPMENT RATES

Shallow water dive spread (Includes: compressor, v-tank, hoses, radio, filter and interconnects)	\$150/day
Mixed Gas Dive Spread (Included: gas rack, spiders, regulators interconnects, HeO ₂ radios)	\$350/day
Recompression Chamber (Includes: O ₂ bibs, comms)	\$250/day
Diving Chamber Compressors (100 to 120 cfm)	\$125/day
Chamber Trailer (double axel; for delivery/pickup)	\$ 75/day
Diving Compressors	\$125/day
100 to 120 cfm (large)	\$ 75/day
50 to 90 cfm (medium)	\$ 50/day
10 to 40 cfm (small)	\$150/day
Dive Stage, davit and tugger	\$150/day
Hydraulic Equipment (For topside or underwater work)	\$175/day
Hydraulic Power Pac (15gpm, 150 ft hose bundle)	\$100/day
Hydraulic Power Pac (8 gpm, 150 ft hose bundle)	\$ 75/day
U/W hydraulic hand tools: (chainsaw, drill, impactor, grinder, jack hammer, etc.)	\$100/day
Hydraulic hose bundle (additional 150ft length)	\$100/day
Pneumatic Equipment (for topside or underwater work)	\$125/day
150 cfm service compressor	\$150/day
350 cfm service compressor	\$ 50/day
6" air lift	\$ 75/day
Rivet Buster/Chipper	\$ 75/day
60 lbs Jack Hammer	\$ 75/day
90 lbs Jack Hammer	\$ 75/day
Circular Saw (8")	\$ 15/day
Points, tips, etc. for tools	\$ 10/day
Pneumatic air supply hose (50" length)	\$ 10/day

Pumps (Includes 10ft suction hose and 50 ft of discharge)

2" Trash Pump	\$ 50/day
3" Trash Pump	\$ 75/day
4" Trash Pump	\$ 95/day
6" Trash Pump	\$175/day
3" Jet Pump	\$ 75/day
4" Jet Pump (600gpm, 150psi)	\$450/day
6" Jet Pump (1000gpm, 250psi)	\$550/day
Additional 50ft lengths discharge hose	\$ 10/day
4" Dredge/Eductor	\$ 35/day
6" Dredge/Eductor	\$ 55/day
Hydroblaster (20gpm, 10Kpsi, includes: 100ft hose, 0-thrust gun)	\$950/day

Welding/Burning Equipment

400 Amp Welder (includes 50ft stinger and ground)	\$150/day
325 Amp Welder (includes 50ft stinger and ground)	\$100/day
250 Amp Welder (includes 50ft stinger and ground)	\$ 65/day
Topside Oxy/Acetylene Burning Set	\$ 35/day
U/W Burning or Welding equipment (300ft, regulator, knife switch, etc.)	\$ 75/day

U/W Video Photography

Underwater video system	\$350/day
Underwater still camera	\$ 75/day
Video production/editing	\$ 82/hr

Floatation (Lift Bags)

1 Ton	\$ 50/day
5 Ton	\$ 75/day
10 Ton	\$225/day

Vehicles/Trailers

Isuzu Cube Truck	\$125/day
16' double axel trailer	\$ 75/day
8' single axel trailer	\$ 50/day
Mileage (includes fuel)	\$ 2. ⁷⁵ /mi

Crane Service (provided at AMC facility)

15 Ton Hydraulic Crane with Operator (1 hr min.)	\$265/hour
45 Ton Crane with Certified Operator (2 hr min.)	\$370/hour
Forklift with Certified Operator (1 hr min.)	\$185/hour

Consumables

All consumables will be charged at: Cost + 15%

Equipment Notes:

- 1) Weekly rates for above listed equipment are determined at 5 time's daily rate.
- 2) Additional equipment can be provided upon request.
- 3) Rates are subject to change without notice.
- 4) For extended projects or utilization, rates are negotiable.
- 5) Rates are for based on availability of American Marine owned equipment.
- 6) Outside rental equipment to be billed at cost + 15%

MONTHLY SUBCONSULTANT MONITORING REPORT

Instructions: Please indicate the SBE/VSBE/MBE/WBE/OBE/DBE participation levels achieved for the month of _____ covered by the referenced contract number.

Contract No. _____ Division _____ Contractor Administrator _____

Contractor _____ *Group _____ Contract Title/Project _____

Contract Amount _____ Start Date _____ End Date _____

Total Amount Invoiced to Date _____

SBE Mandated Participation Percentage _____ SBE _____ VSBE _____

Proposed Subcontractor Percentage _____ MBE _____ WBE _____ OBE _____ DVBE _____

	Name of Subcontractor	Type of Work Performed	Group SBE/VSBE/MBE/WBE/OBE/DBE	PROPOSED			ACTUALS		
				Original Proposed Amount	Original Proposed Percentage	Amount Paid to Date	Amount Paid to Date Percentage	Contract Amount Percentage	
1									
2									
3									
4									
5									
6									
7									
8									
9									
10									

Directions:
 Original Proposed Percentage: Original Proposed Percentage of Total Contract Amount
 Amount Paid to Date Percentage: Percentage of Total Amount Invoiced to Date
 Contract Amount Percentage: Percentage Paid to Date of Total Contract Amount

* Group = (SBE/VSBE/MBE/WBE/OBE/DVBE/DBE)

EXHIBIT D

BUSINESS TAX REGISTRATION CERTIFICATE (BTRC) NUMBER

The City of Los Angeles Office of Finance requires all firms that engage in any business activity within the City of Los Angeles to pay City business taxes. Each firm or individual (other than a municipal employee) is required to obtain the necessary Business Tax Registration Certification (BTRC) and pay business tax. (Los Angeles Municipal Code Section 21.09 et seq.)

All firms and individuals that do business with the City of Los Angeles will be required to provide a BTRC number or an exemption number as proof of compliance with Los Angeles City business tax requirements in order to receive payment for goods or services. Beginning October 14, 1987, payments for goods or services will be withheld unless proof of tax compliance is provided to the City.

The Tax and Permit Division of Los Angeles Office of Finance has the sole authority to determine whether a firm is covered by business tax requirements. Those firms not required to pay will be given an exemption number.

If you do NOT have a BTRC number contact the Tax and Permit Division at the office listed below, or log on to www.lacity.org/finance to download the business tax registration application.

MAIN OFFICE

LA City Hall

201 N. Main Street, Rm. 101 (844) 663-4411

EXHIBIT E - AFFIRMATIVE ACTION PROGRAM PROVISIONS

Sec. 10.8.4 Affirmative Action Program Provisions.

Every non-construction contract with or on behalf of the City of Los Angeles for which the consideration is \$100,000 or more and every construction contract with or on behalf of the City of Los Angeles for which the consideration is \$5,000 or more shall contain the following provisions which shall be designated as the AFFIRMATIVE ACTION PROGRAM provisions of such contract:

- A. During the performance of City contract, the contractor certifies and represents that the contractor and each subcontractor hereunder will adhere to an affirmative action program to ensure that in its employment practices, persons are employed and employees are treated equally and without regard to or because of race, religion, ancestry, national origin, sex, sexual orientation, age, disability, marital status, domestic partner status, or medical condition.
 - 1. This provision applies to work or services performed or materials manufactured or assembled in the United States.
 - 2. Nothing in this section shall require or prohibit the establishment of new classifications of employees in any given craft, work or service category.
 - 3. The contractor shall post a copy of Paragraph A hereof in conspicuous places at its place of business available to employees and applicants for employment.
- B. The contractor will, in all solicitations or advertisements for employees placed by or on behalf of the contractor, state that all qualified applicants will receive consideration for employment without regard to their race, religion, ancestry, national origin, sex, sexual orientation, age, disability, marital status, domestic partner status, or medical condition.
- C. As part of the City's supplier registration process, and/or at the request of the awarding authority or the Office of Contract Compliance, the contractor shall certify on an electronic or hard copy form to be supplied, that the contractor has not discriminated in the performance of City contracts against any employee or applicant for employment on the basis or because of race, religion, ancestry, national origin, sex, sexual orientation, age, disability, marital status, domestic partner status, or medical condition.
- D. The contractor shall permit access to and may be required to provide certified copies of all of its records pertaining to employment and to its employment practices by the awarding authority or the Office of Contract Compliance, for the purpose of investigation to ascertain compliance with the Affirmative Action Program provisions of City contracts, and on their or either of their request to provide evidence that it has or will comply therewith.

- E. The failure of any contractor to comply with the Affirmative Action Program provisions of City contracts may be deemed to be a material breach of contract. Such failure shall only be established upon a finding to that effect by the awarding authority, on the basis of its own investigation or that of the Board of Public Works, Office of Contract Compliance. No such finding shall be made except upon a full and fair hearing after notice and an opportunity to be heard has been given to the contractor.
- F. Upon a finding duly made that the contractor has breached the Affirmative Action Program provisions of a City contract, the contract may be forthwith cancelled, terminated or suspended, in whole or in part, by the awarding authority, and all monies due or to become due hereunder may be forwarded to and retained by the City of Los Angeles. In addition thereto, such breach may be the basis for a determination by the awarding authority or the Board of Public Works that the said contractor is an irresponsible bidder or proposer pursuant to the provisions of Section 371 of the Los Angeles City Charter. In the event of such determination, such contractor shall be disqualified from being awarded a contract with the City of Los Angeles for a period of two years, or until he or she shall establish and carry out a program in conformance with the provisions hereof.
- G. In the event of a finding by the Fair Employment and Housing Commission of the State of California, or the Board of Public Works of the City of Los Angeles, or any court of competent jurisdiction, that the contractor has been guilty of a willful violation of the California Fair Employment and Housing Act, or the Affirmative Action Program provisions of a City contract, there may be deducted from the amount payable to the contractor by the City of Los Angeles under the contract, a penalty of TEN DOLLARS (\$10.00) for each person for each calendar day on which such person was discriminated against in violation of the provisions of a City contract.
- H. Notwithstanding any other provisions of a City contract, the City of Los Angeles shall have any and all other remedies at law or in equity for any breach hereof.
- I. The Public Works Board of Commissioners shall promulgate rules and regulations through the Office of Contract Compliance and provide to the awarding authorities electronic and hard copy forms for the implementation of the Affirmative Action Program provisions of City contracts, and rules and regulations and forms shall, so far as practicable, be similar to those adopted in applicable Federal Executive Orders. No other rules, regulations or forms may be used by an awarding authority of the City to accomplish this contract compliance program.
- J. Nothing contained in City contracts shall be construed in any manner so as to require or permit any act which is prohibited by law.
- K. The Contractor shall submit an Affirmative Action Plan which shall meet the requirements of this chapter at the time it submits its bid or proposal or at the time it registers to do business with the City. The plan shall be subject to approval by the

Office of Contract Compliance prior to award of the contract. The awarding authority may also require contractors and suppliers to take part in a pre-registration, pre-bid, pre-proposal, or pre-award conference in order to develop, improve or implement a qualifying Affirmative Action Plan. Affirmative Action Programs developed pursuant to this section shall be effective for a period of twelve

months from the date of approval by the Office of Contract Compliance. In case of prior submission of a plan, the contractor may submit documentation that it has an Affirmative Action Plan approved by the Office of Contract Compliance within the previous twelve months. If the approval is 30 days or less from expiration, the contractor must submit a new Plan to the Office of Contract Compliance and that Plan must be approved before the contract is awarded.

1. Every contract of \$5,000 or more which may provide construction, demolition, renovation, conservation or major maintenance of any kind shall in addition comply with the requirements of Section 10.13 of the Los Angeles Administrative Code.
 2. A contractor may establish and adopt as its own Affirmative Action Plan, by affixing his or her signature thereto, an Affirmative Action Plan prepared and furnished by the Office of Contract Compliance, or it may prepare and submit its own Plan for approval.
- L. The Office of Contract Compliance shall annually supply the awarding authorities of the City with a list of contractors and suppliers who have developed Affirmative Action Programs. For each contractor and supplier the Office of Contract Compliance shall state the date the approval expires. The Office of Contract Compliance shall not withdraw its approval for any Affirmative Action Plan or change the Affirmative Action Plan after the date of contract award for the entire contract term without the mutual agreement of the awarding authority and the contractor.
- M. The Affirmative Action Plan required to be submitted hereunder and the pre-registration, pre-bid, pre-proposal or pre-award conference which may be required by the Board of Public Works, Office of Contract Compliance or the awarding authority shall, without limitation as to the subject or nature of employment activity, be concerned with such employment practices as:
1. Apprenticeship where approved programs are functioning, and other on-the-job training for non-apprenticeable occupations;
 2. Classroom preparation for the job when not apprenticeable;
 3. Pre-apprenticeship education and preparation;
 4. Upgrading training and opportunities;

5. Encouraging the use of contractors, subcontractors and suppliers of all racial and ethnic groups, provided, however, that any contract subject to this ordinance shall require the contractor, subcontractor or supplier to provide not less than the prevailing wage, working conditions and practices generally observed in private industries in the contractor's, subcontractor's or supplier's geographical area for such work;
 6. The entry of qualified women, minority and all other journeymen into the industry; and
 7. The provision of needed supplies or job conditions to permit persons with disabilities to be employed, and minimize the impact of any disability.
- N. Any adjustments which may be made in the contractor's or supplier's workforce to achieve the requirements of the City's Affirmative Action Contract Compliance Program in purchasing and construction shall be accomplished by either an increase in the size of the workforce or replacement of those employees who leave the workforce by reason of resignation, retirement or death and not by termination, layoff, demotion or change in grade.
- O. Affirmative Action Agreements resulting from the proposed Affirmative Action Plan or the pre-registration, pre-bid, pre-proposal or pre-award conferences shall not be confidential and may be publicized by the contractor at his or her discretion. Approved Affirmative Action Agreements become the property of the City and may be used at the discretion of the City in its Contract Compliance Affirmative Action Program.
- P. This ordinance shall not confer upon the City of Los Angeles or any Agency, Board or Commission thereof any power not otherwise provided by law to determine the legality of any existing collective bargaining agreement and shall have application only to discriminatory employment practices by contractors or suppliers engaged in the performance of City contracts.
- Q. All contractors subject to the provisions of this section shall include a like provision in all subcontracts awarded for work to be performed under the contract with the City and shall impose the same obligations, including but not limited to filing and reporting obligations, on the subcontractors as are applicable to the contractor. Failure of the contractor to comply with this requirement or to obtain the compliance of its subcontractors with all such obligations shall subject the contractor to the imposition of any and all sanctions allowed by law, including but not limited to termination of the contractor's contract with the City.

EXHIBIT F

(1) SMALL/VERY SMALL BUSINESS ENTERPRISE PROGRAM

(2) LOCAL BUSINESS PREFERENCE PROGRAM

(1) SMALL/VERY SMALL BUSINESS ENTERPRISE PROGRAM:

The Harbor Department is committed to creating an environment that provides all individuals and businesses open access to the business opportunities available at the Harbor Department in a manner that reflects the diversity of the City of Los Angeles. The Harbor Department's Small Business Enterprise (SBE) Program was created to provide additional opportunities for small businesses to participate in professional service and construction contracts. An overall Department goal of 25% SBE participation, including 5% Very Small Business Enterprise (VSBE) participation, has been established for the Program. The specific goal or requirement for each contract opportunity may be higher or lower based on the scope of work.

It is the policy of the Harbor Department to solicit participation in the performance of all service contracts by all individuals and businesses, including, but not limited to, SBEs, VSBEs, women-owned business enterprises (WBEs), minority-owned business enterprises (MBEs), and disabled veteran business enterprises (DVBEs). The SBE Program allows the Harbor Department to target small business participation, including MBEs, WBEs, and DVBEs, more effectively. It is the intent of the Harbor Department to make it easier for small businesses to participate in contracts by providing education and assistance on how to do business with the City, and ensuring that payments to small businesses are processed in a timely manner. **In order to ensure the highest participation of SBE/VSBE/MBE/WBE/DVBEs, all proposers shall utilize the City's contracts management and opportunities database, the Los Angeles Business Assistance Virtual Network (LABAVN), at <http://www.labavn.org>, to outreach to potential subconsultants.**

The Harbor Department defines a SBE as an independently owned and operated business that is not dominant in its field and meets criteria set forth by the Small Business Administration in Title 13, Code of Federal Regulations, Part 121. Go to www.sba.gov for more information. The Harbor Department defines a VSBE based on the State of California's Micro-business definition which is 1) a small business that has average annual gross receipts of \$3,500,000 or less within the previous three years, or (2) a small business manufacturer with 25 or fewer employees.

The SBE Program is a results-oriented program, requiring consultants who receive contracts from the Harbor Department to perform outreach and utilize certified small businesses. **Based on the work to be performed, it has been determined that the percentage of small business participation will be 0%, including 0% VSBE participation.** The North American Industry Classification System (NAICS) Code for the scope of services is **561990**. This NAICS Code is the industry code that corresponds to at least 51% of the scope of services and will be used to determine the size standard for SBE participation of the Prime Consultant. The maximum SBE size standard for this NAICS Code is \$11 million.

Consultant shall be responsible for determining the SBE status of its subconsultants for purposes of meeting the small business requirement. Subconsultants must qualify as an SBE based on the type of services that they will be performing under the Agreement. All business participation will be determined by the percentage of the total amount of compensation under the agreement paid to SBEs. The Consultant shall not substitute an SBE firm without obtaining prior approval of the City. A request for substitution must be based upon demonstrated good cause. If substitution is permitted, Consultant shall endeavor to make an in-kind substitution for the substituted SBE.

Consultant shall complete, sign, and submit as part of the executed agreement the attached Affidavit and Consultant Description Form. The Affidavit and Consultant Description Form, when signed, will signify the Consultant's intent to comply with the SBE requirement. All SBE/VSBE firms must be certified by the time proposals are due to receive credit. In addition all consultants and subconsultants must be registered on the LABAVN by the time proposals are due.

(2) LOCAL BUSINESS PREFERENCE PROGRAM:

The Harbor Department is committed to maximizing opportunities for local and regional businesses, as well as encouraging local and regional businesses to locate and operate within the Southern California region. It is the policy of the Harbor Department to support an increase in local and regional jobs. The Harbor Department's Local Business Preference Program (LBPP) aims to benefit the Southern California region by increasing jobs and expenditures within the local and regional private sector.

Consultants who qualify as a Local Business Enterprise (LBE) will receive an 8% preference on any proposal for services valued in excess of \$150,000. The preference will be applied by adding 8% of the total possible evaluation points to the Consultant's score. Consultants who do not qualify as a LBE may receive a maximum 5% preference for identifying and utilizing LBE subconsultants. Consultants may receive 1% preference, up to a maximum of 5%, for every 10% or portion thereof, of work that is subcontracted to a LBE. LBE subconsultant preferences will be determined by the percentage of the total amount of compensation proposed under the Agreement.

The Harbor Department defines a LBE as:

- (a) A business headquartered within Los Angeles, Orange, Riverside, San Bernardino, or Ventura Counties. Headquartered shall mean that the business physically conducts and manages all of its operations from a location in the above-named counties; or
- (b) A business that has at least 50 full-time employees, or 25 full-time employees for specialty marine contracting firms, working in Los Angeles, Orange, Riverside, San Bernardino, or Ventura Counties.

In order for Harbor Department staff to determine the appropriate LBE preference, Consultant shall complete, sign, notarize (where applicable) and submit the attached Affidavit and Consultant Description Form. The Affidavit and Consultant Description Form will signify the LBE status of the Consultant and subconsultants.

In the event of Consultant's noncompliance during the performance of the Agreement, Consultant shall be considered in material breach of contract. In addition to any other remedy available to City under this Agreement or by operation of law, the City may withhold invoice payments to Consultant until noncompliance is corrected, and assess the costs of City's audit of books and records of Consultant and its subconsultants. In the event the Consultant falsifies or misrepresents information contained in any form or other willful noncompliance as determined by City, City may disqualify the Consultant from participation in City contracts for a period of up to five (5) years.

AFFIDAVIT OF COMPANY STATUS

"The undersigned declares under penalty of perjury pursuant to the laws of the State of California that the following information and information contained on the **attached Consultant Description Form** is true and correct and includes all material information necessary to identify and explain the operations of

American Marine Corporation

Name of Firm

as well as the ownership and location thereof. Further, the undersigned agrees to provide complete and accurate information regarding ownership in the named firm, and all of its domestic and foreign affiliates, any proposed changes of the ownership and to permit the audit and examination of firm ownership documents, and the ownership documents of all of its domestic and foreign affiliates, in association with this agreement."

(1) **Small/Very Small Business Enterprise Program:** Please indicate the ownership of your company. Please check all that apply. At least one box must be checked:

SBE VSBE MBE WBE DVBE OBE

- A Small Business Enterprise (SBE) is an independently owned and operated business that is not dominant in its field and meets criteria set forth by the Small Business Administration in Title 13, Code of Federal Regulations, Part 121.
- A Very Small Business Enterprise (VSBE) is 1) a small business that has average annual gross receipts of \$3,500,000 or less within the previous three years, or (2) a small business manufacturer with 25 or fewer employees.
- A Minority Business Enterprise (MBE) is defined as a business in which a minority owns and controls at least 51% of the business. A Woman Business (WBE) is defined as a business in which a woman owns and controls at least 51% of the business. For the purpose of this project, a minority includes:
 - (1) Black (all persons having origins in any of the Black African racial groups not of Hispanic origin);
 - (2) Hispanic (all persons of Mexican, Puerto Rican, Cuban, Central or South American or other Spanish Culture or origin, regardless of race);
 - (3) Asian and Pacific Islander (all persons having origins in any of the original peoples of the Far East, Southeast Asia, The Indian Subcontinent, or the Pacific Islands); and
 - (4) American Indian or Alaskan Native (all persons having origins in any of the original peoples of North America and maintaining identifiable tribal affiliations through membership and participation or community identification).
- A Disabled Veteran Business Enterprise (DVBE) is defined as a business in which a disabled veteran owns at least 51% of the business, and the daily business operations are managed and controlled by one or more disabled veterans.
- An OBE (Other Business Enterprise) is any enterprise that is neither an SBE, VSBE, MBE, WBE, or DVBE.

Consultant Description Form

PRIME CONSULTANT:

Contract Title: On Call Hard Hat Diving Services
Business Name: American Marine Corp LABAVN ID#: 36253
Award Total: \$ _____
Owner's Ethnicity: CAU Gender Male Group (SBE) VSBE MBE WBE DVBE OBE (Circle all that apply)
Local Business Enterprise: YES X NO _____ (Check only one)
Primary NAICS Code: 483111 Average Three Year Gross Revenue: \$ 2,180,000.
Address: 1500 South Barracuda Street
City/State/Zip: Terminal Island, CA, 90731
County: Los Angeles
Telephone: (310) 547-0919 FAX: (310) 547-0031
Contact Person/Title: Michael Dunn/ Diving Operations Manager
Email Address: michael.dunn@amarinecorp.com

SUBCONSULTANT:

Business Name: NONE LABAVN ID#: _____
Award Total: (% or \$): _____
Services to be provided: _____
Owner's Ethnicity: _____ Gender _____ Group: SBE VSBE MBE WBE DVBE OBE (Circle all that apply)
Local Business Enterprise: YES _____ NO _____ (Check only one)
Primary NAICS Code: _____ Average Three Year Gross Revenue: \$ _____
Address: _____
City/State/Zip: _____
County: _____
Telephone: () _____ FAX: () _____
Contact Person/Title: _____
Email Address: _____

SUBCONSULTANT:

Business Name: N/A LABAVN ID#: _____
Award Total: (% or \$): _____
Services to be provided: _____
Owner's Ethnicity: _____ Gender _____ Group: SBE VSBE MBE WBE DVBE OBE (Circle all that apply)
Local Business Enterprise: YES _____ NO _____ (Check only one)
Primary NAICS Code: _____ Average Three Year Gross Revenue: \$ _____
Address: _____
City/State/Zip: _____
County: _____
Telephone: () _____ FAX: () _____
Contact Person/Title: _____
Email address: _____

EXHIBIT G

Sec. 10.8.2.1. Equal Benefits Ordinance.

Discrimination in the provision of employee benefits between employees with domestic partners and employees with spouses results in unequal pay for equal work. Los Angeles law prohibits entities doing business with the City from discriminating in employment practices based on marital status and/or sexual orientation. The City's departments and contracting agents are required to place in all City contracts a provision that the company choosing to do business with the City agrees to comply with the City's nondiscrimination laws.

It is the City's intent, through the contracting practices outlined in this Ordinance, to assure that those companies wanting to do business with the City will equalize the total compensation between similarly situated employees with spouses and with domestic partners. The provisions of this Ordinance are designed to ensure that the City's contractors will maintain a competitive advantage in recruiting and retaining capable employees, thereby improving the quality of the goods and services the City and its people receive, and ensuring protection of the City's property.

(c) Equal Benefits Requirements.

(1) No Awarding Authority of the City shall execute or amend any Contract with any Contractor that discriminates in the provision of Benefits between employees with spouses and employees with Domestic Partners, between spouses of employees and Domestic Partners of employees, and between dependents and family members of spouses and dependents and family members of Domestic Partners.

(2) A Contractor must permit access to, and upon request, must provide certified copies of all of its records pertaining to its Benefits policies and its employment policies and practices to the DAA, for the purpose of investigation or to ascertain compliance with the Equal Benefits Ordinance.

(3) A Contractor must post a copy of the following statement in conspicuous places at its place of business available to employees and applicants for employment: "During the performance of a Contract with the City of Los Angeles, the Contractor will provide equal benefits to its employees with spouses and its employees with domestic partners." The posted statement must also include a City contact telephone number which will be provided each Contractor when the Contract is executed.

(4) A Contractor must not set up or use its contracting entity for the purpose of evading the requirements imposed by the Equal Benefits Ordinance.

(d) Other Options for Compliance. Provided that the Contractor does not discriminate in the provision of Benefits, a Contractor may also comply with the Equal Benefits Ordinance in the following ways:

(1) A Contractor may provide an employee with the Cash Equivalent only if the DAA determines that either:

a. The Contractor has made a reasonable, yet unsuccessful effort to provide Equal Benefits; or

b. Under the circumstances, it would be unreasonable to require the Contractor to provide Benefits to the Domestic Partner (or spouse, if applicable).

(2) Allow each employee to designate a legally domiciled member of the employee's household as being eligible for spousal equivalent Benefits.

(3) Provide Benefits neither to employees' spouses nor to employees' Domestic Partners.

(e) Applicability.

(1) Unless otherwise exempt, a Contractor is subject to and shall comply with all applicable provisions of the Equal Benefits Ordinance.

(2) The requirements of the Equal Benefits Ordinance shall apply to a Contractor's operations as follows:

a. A Contractor's operations located within the City limits, regardless of whether there are employees at those locations performing work on the Contract.

b. A Contractor's operations on real property located outside of the City limits if the property is owned by the City or the City has a right to occupy the property, and if the Contractor's presence at or on that property is connected to a Contract with the City.

c. The Contractor's employees located elsewhere in the United States but outside of the City limits if those employees are performing work on the City Contract.

(3) The requirements of the Equal Benefits Ordinance do not apply to collective bargaining agreements ("CBA") in effect prior to January 1, 2000. The Contractor must agree to propose to its union that the requirements of the Equal Benefits Ordinance be incorporated into its CBA upon amendment, extension, or other modification of a CBA occurring after January 1, 2000.

(f) **Mandatory Contract Provisions Pertaining to Equal Benefits.** Unless otherwise exempted, every Contract shall contain language that obligates the Contractor to comply with the applicable provisions of the Equal Benefits Ordinance. The language shall include provisions for the following:

(1) During the performance of the Contract, the Contractor certifies and represents that the Contractor will comply with the Equal Benefits Ordinance.

(2) The failure of the Contractor to comply with the Equal Benefits Ordinance will be deemed to be a material breach of the Contract by the Awarding Authority.

(3) If the Contractor fails to comply with the Equal Benefits Ordinance the Awarding Authority may cancel, terminate or suspend the Contract, in whole or in part, and all monies due or to become due under the Contract may be retained by the City. The City may also pursue any and all other remedies at law or in equity for any breach.

(4) Failure to comply with the Equal Benefits Ordinance may be used as evidence against the Contractor in actions taken pursuant to the provisions of Los Angeles Administrative Code Section 10.40, et seq., Contractor Responsibility Ordinance.

(5) If the DAA determines that a Contractor has set up or used its Contracting entity for the purpose of evading the intent of the Equal Benefits Ordinance, the Awarding Authority may terminate the Contract on behalf of the City. Violation of this provision may be used as evidence against the Contractor in actions taken pursuant to the provisions of Los Angeles Administrative Code Section 10.40, et seq., Contractor Responsibility Ordinance.