

TO: HARBOR DEPARTMENT PURCHASING OFFICE
 500 Pier "A" Street
 Berth 161
 Wilmington, CA 90744

BID NO. F-1210 Page 1
 Show this number on envelope

Contract No. 40051

1. COMPLETE CONTRACT

This entire Bid Request shall become the contract upon its execution by the Executive Director on behalf of the Harbor Department of the City of Los Angeles. The complete contract shall consist of the entire Bid (including Specifications), this page, terms and conditions, any addendums, and when required, CONTRACTOR'S BOND. Contractor will be provided with a copy of the executed contract.

2. GOODS AND SERVICES TO BE PROVIDED BY THE CONTRACTOR

The Contractor agrees, upon acceptance of this offer by the City, to furnish the goods and services herein specified according to the terms and conditions as set forth herein.

3. AMOUNT TO BE PAID

The City agrees to pay the Contractor for the goods or services in the manner described in the paragraph entitled "PAYMENTS" on the reverse side of this form. Unless otherwise indicated by the Bidder, remittance by the City for goods or services will be made to the address below.

4 CHOICE OF ALTERNATIVE PROVISIONS; OPTIONS; NOTIFICATION

When alternative provisions are requested, or options are offered, the Contractor will be notified as to which provision, or option, is Being accepted when notification is sent that the Contractor is the successful bidder.

5. DECLARATION OF NON-COLLUSION

The undersigned certifies (or declares) under penalty of perjury that this bid is genuine and not sham or collusive, or made in the interest or on behalf of any person, firm, or corporation not herein named; that the bidder has not directly or indirectly induced or solicited any other bidder to put up a sham bid, or any other person, firm or corporation to refrain from bidding, and that the bidder has not in any manner sought by collusion to secure any advantage over other bidders.

6. LEGAL JUSTIFICATION

This agreement shall be deemed entered into in Los Angeles, California, and shall be governed and construed in accordance with the laws of the State of California.

EXECUTED AT: _____ ON THE _____ DAY OF _____, 2024
City, State Date Month Year

BIDDER MUST COMPLETE AND SIGN BELOW:

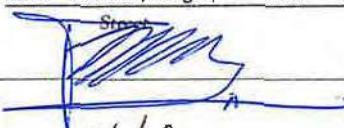

Firm Name Cavotec USA Inc.
 Phone (704) 242-3678 / 873-3009 Fax _____
 Address 500 S. Main St, Bldg 1, Suite 109 Mooresville North Carolina 28155
Street City State Zip
 Signature  Printed Name Alfredo Rivas Printed Title POA / Regional Sales Director Americas
N/A N/A N/A



(AFFIX CORPORATE SEAL HERE)

- (Approved Corporate Signature Methods)
- a) **Two signatures:** One by Chairman of Board of Directors, President, or a Vice-President **AND** one by Secretary, Assistant Secretary, Chief Financial Officer or an Assistant Treasurer.
 - b) **One signature:** By corporate designated individual together with properly attested resolution of Board of Directors authorizing person to sign.

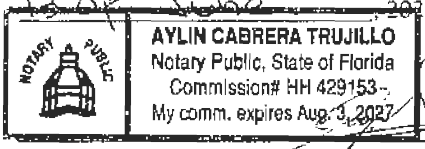
NOTARIZATION: Bids executed outside the State of California must be sworn to and notarized below.

County of <u>DeWard</u> State of <u>Florida</u> S.S. Subscribed and sworn this date <u>13th of June</u> , 2024  <small>Notary Seal Signature</small>	In witness whereof the Board of Harbor Commissioners of the City of Los Angeles has caused this contract to be executed by the Executive Director of the Harbor Department of said City and said Contractor has executed this contract the day and year written below. By _____ Executive Director Harbor Department _____ Date	Approved as to form and legality <u>June 24</u> , 2024 City Attorney BY  Deputy <p style="text-align: center; font-weight: bold;">TRANSMITTAL 1</p>
---	---	---

Date: 9/10/2024

Contractor/Vendor Name: 40051/Cavotec

Account#	<u>59994</u>	W.O. #	<u>2580600</u>
Ctr/Div#	<u>1186/000</u>	Job Fac.#	<u>2690233</u>
Proj/Prog#	<u>2580600</u>		
	Budget FY:	Amount:	
	2025/2026	\$1,182,084.38	
	TOTAL:	\$1,182,084.38	

For Acct/Budget Div. Use Only

Verified by: Flora Khaw Digitally signed by Flora Khaw
Date: 2024.09.11 06:24:51
-07'00'

Verified Funds Available:  Digitally signed by Frank Liu
Date: 2024.09.11 07:44:56
-07'00'

Date Approved: 9/11/24

REQUEST FOR BIDS

**CITY OF LOS ANGELES
HARBOR DEPARTMENT**

NO. F-1210

<p><u>SUBMIT BID TO:</u> Los Angeles Harbor Department Purchasing Office, 1st Floor 500 Pier A Street Wilmington, CA 90744</p> <p><u>OFFICE HOURS:</u> 7:30 a.m. – 4:30 p.m. Monday through Friday (excluding Holidays)</p>	<p>BID DUE BEFORE 2:00 P.M. JUNE 14, 2024</p>
<p>Buyer: Jacquelyn L. Estrada, Procurement Analyst Email: jestrada@portla.org</p>	<p>BIDS WILL BE PUBLICLY OPENED</p>

ALL ITEMS REQUESTED MAY BE QUOTED AS "OR EQUAL".
AFFIRMATIVE ACTION – AN APPROVED AA PLAN OR CERTIFICATION, IF NOT ON FILE, WILL BE REQUIRED PRIOR TO AWARD OF CONTRACT.

COVOTEC POWERMOVE MINI TOWABLE SHORE POWER CONNECTION SYSTEM

Bids are requested for the one-time requirements of the Los Angeles Harbor Department ("Department" or "City") for a Cavotec PowerMove Mini Towable Shore Power Connection System** to be furnished and delivered as may be required from the effective date of the Contract.

PRICES TO INCLUDE ALL DELIVERY CHARGES AND FEES EXCLUDING SALES TAX.

Line	Description	Taxable	UOM	Qty	Unit Cost	Extended Cost
1	001-CMSS1 - Cavotec 031017- T02c PowerMove Mini Towable 40 m – 20 MVA @11 KV, HV Cables and Spare Parts Included.	Y	EA	1	\$ 984,025.00	\$ 984,025.00
1C	N/A	Y	EA	1	\$ 0.00	\$ 0.00
2	Common Carrier Freight Costs	N	LOT	1	\$ 59,570.00	\$ 59,570.00
3	Delivery by Vendor	Y	LOT	1	\$ 0.00	\$ 0.00
4	Documentation and Registration Fees		LOT	1	\$ 45,000.00	\$ 45,000.00
5	Tire Fees		LOT	1	\$ 7.00	\$ 7.00
Grand Total (Excluding Sales Tax)					\$ *****	1,088,602.00

****Full Specifications Per "Attachment A"**

<p>REQ. NO.: G-24-082 (93822) NOTIFY: M. Arca PAGE 2 052224 JLE</p>	<p>STATE TIME OF DELIVERY: <u>525</u> DAYS AFTER RECEIPT OF ORDER TERMS DISCOUNT FOR PAYMENT WITHIN <u>0</u> DAYS. BIDDER MUST SIGN THIS BID ON PAGE 1 – WET SIGNATURES REQUIRED</p>
---	---

REQUEST FOR BIDS

CITY OF LOS ANGELES
HARBOR DEPARTMENT

NO. F-1210
(SHOW THIS NUMBER ON ENVELOPE)

OPTIONS

PER ATTACHMENT A

BIDDERS' INSTRUCTIONS

REQUEST FOR QUOTATION BIDDER RESPONSIVENESS. In order to be responsive, Bidders ("Contractor", "Vendor", "Supplier") shall complete and return all Quotation documents requested by the Los Angeles Harbor Department, including addenda, specifications, drawings and all forms.

It shall be the bidder's responsibility to **provide one (1) original and one (1) copy** of the completed Quotation documents. The original and all copies shall include all quotation documents requested by the Department, including addenda, specifications, drawings and all forms.

The Director of the Contracts and Purchasing Division ("Director") may deem a bidder non-responsive if the bidder fails to provide all Quotation documents requested by the Department at the Quotation closing date and time.

MAKES, MODELS AND BRAND NAMES. Makes, Models and Brand Names referenced are for illustrative or descriptive purposes only, and are not intended to be restrictive to any particular product. If bidder proposes to furnish another product equal in quality and purpose, such bids will be considered as long as they materially comply with the specifications. Alternate Make, Model, Brand Names, and/or Catalog Number(s) must be indicated opposite each item in the space provided.

If bidding a comparable item, the specified Make, Model, and Brand Name must be furnished in the shaded space labeled "C" above, unless otherwise specified by bidder.

ADDENDA. From time to time, the Harbor Department may deem it necessary to issue an addendum(a) to modify or cancel a Bid Request. Such addendum(a) will be available on the Port of Los Angeles internet website – <http://www.portoflosangeles.org/> and the Los Angeles Regional Alliance Marketplace for Procurement website – <https://www.rampla.org/s/> . It is the responsibility of the bidder to be aware of, and respond to, any such addendum(a) before the deadline of the applicable bid request. Failure to do so may deem the bid non-responsive.

TECHNICAL CORRECTIONS. The Executive Director or his designee is authorized to make minor technical corrections or clarifications in order to effectuate the intent of this contract/bid.

BID SUBMITTAL TIMELINESS.

Bidders solely are responsible for the timeliness of their submittals. As such, bidders are cautioned to budget adequate time to ensure that their bids are delivered at the location designated at or before the deadline set forth above. Bidders are cautioned that matters including, but not limited to, power and internet outages, traffic congestion, security measures and/or events in or around the Port of Los Angeles, may lengthen the amount of time necessary to deliver the bid, whether the bid is submitted in person or by mail.

PRE-AWARD CONFERENCE. Prior to award of contract, the vendor may be required to attend a pre-award conference to be scheduled at a later date. The intent of this meeting will be to discuss contract regulations, specifications, invoicing, delivery times, etc., in order to ensure successful administration of the contract.

REQUEST FOR BIDS

CITY OF LOS ANGELES
HARBOR DEPARTMENT

NO. F-1210
(SHOW THIS NUMBER ON ENVELOPE)

SPECIFICATION CHANGES. If any provisions of the Specifications preclude bidder from submitting a bid, bidder may request in writing that the specifications be modified. Such request must be received by the Director of Contracts and Purchasing at least five (5) working days before the bid due date. All bidders will be notified by Addendum of any approved changes to the specifications.

AWARD OF CONTRACT. Bid shall be subject to acceptance by the Department for a period of three (3) months unless a lesser period is prescribed in the quotation by the bidder. The Department may make combined award of all items complete to one bidder or may award separate items to various bidders. Bidders may submit alternate prices, a lump sum or a discount conditional on receiving an award for two or more items. *The right is reserved to reject any, or all, bids and to waive informality in bids.*

AWARD. The Harbor Department reserves the right to reject any or all Bids, award Bid as a whole, split award or delete line items, as it may deem necessary, unless otherwise stated herein.

BID RECAPS. Bid recaps, with a summary of all bids received, will be posted to the following website within two weeks of the bid closing date: <https://www.portoflosangeles.org/business/contracting-opportunities/purchasing-bids>

REQUEST FOR BIDS

CITY OF LOS ANGELES
HARBOR DEPARTMENT

NO. F-1210
(SHOW THIS NUMBER ON ENVELOPE)

CONTRACTUAL TERMS SECTION

SUPPLIER CONTACT INFORMATION FOR DELIVERY AND PAYMENT ISSUES.

Contact Person: Alfredo Rivas
Title: Regional Sales Director Americas
Telephone: (704) 242-3678
Email Address: alfredo.rivas@cavotec.com

SUPPLIER CONTACT INFORMATION FOR WARRANTY AND REPAIR ISSUES.

(If Different from Above)

Contact Person: Toney Graham
Title: Inside Sales & Service Manager
Telephone: (704) 873-3009 Ext. 2232
Email Address: toney.graham@cavotec.com

AUTHORIZED DISTRIBUTOR/DEALER. Bidder must indicate if it is an authorized factory distributor/dealer for the manufacturer(s) being quoted (please check one and initial).

Yes: AR No: _____

The manufacturer will be responsible for any default of the supplier that is not corrected by the supplier in a timely and efficient manner. This responsibility includes replacing incorrect or defective parts, troubleshooting, and correcting problems that are traceable to the manufacturer.

NEW AND UNUSED. The equipment and materials furnished shall be new and unused, current model or offering.

WARRANTY. Terms of warranty on new materials offered. Free PARTS AND SERVICE (LABOR) for defective materials and workmanship for the following time period after goods and/or work have been accepted:

Materials: 12 months from commissioning day.

Please attach additional warranty terms with bid, if applicable.

REQUEST FOR BIDS

CITY OF LOS ANGELES
HARBOR DEPARTMENT

NO. F-1210
(SHOW THIS NUMBER ON ENVELOPE)

BUSINESS HOURS:

Vendor to indicate business hours:

Monday-Friday: 8:00 A.M. to 5:00 P.M.

Saturday: _____ A.M. to _____ P.M. Closed

Sunday: _____ A.M. to _____ P.M. Closed

RECYCLED PRODUCT CONTENT.

Bidder shall provide the following information with its Quotation.

Is Recycled Product Available (Tires Only): Yes No

If yes, state brand, model and/or cat. no:

Recycled content: _____%

Post-consumer waste: _____%

Secondary waste: _____%

DELIVERY

DELIVERY POINT. Unless otherwise quoted, prices to include all delivery charges, F.O.B. the Harbor Department, Port of Los Angeles, 500 Pier A Street, Warehouse, Wilmington, CA 90744, or as directed by Department personnel.

NOTIFICATION. The vendor shall notify Mark Arca of the Harbor Department at MArca@portla.org not less than five (5) days in advance that the Unit is ready for the following inspections: (1) Pre-delivery inspection of completed vehicle, (2) Final inspection at point of delivery.

SHIPPING CHARGES. Please prepay and add shipping or delivery charges to your invoices. Ship cheapest way, unless otherwise specified herein, for goods to arrive within the time specified above. Please include copy of your freight bill with your invoice. AIR SHIPMENT MUST BE SPECIFICALLY AUTHORIZED BY STATEMENT ON THIS ORDER.

DELIVERY CHARGES – BY VENDOR. Delivery charges for parts and materials, delivered by vendor. Delivery charges are not subject to markup.

REQUEST FOR BIDS

CITY OF LOS ANGELES
HARBOR DEPARTMENT

NO. F-1210
(SHOW THIS NUMBER ON ENVELOPE)

FINANCIAL CLAUSES

SALES TAXES. Do not include Sales Taxes in your Bid. Sales Taxes will be added at time of order.

SALES TAX PERMIT. A valid California State Board of Equalization Seller's Permit Number is required to collect California State Sales Tax.

Permit Number: _____, N/A (Sales Tax will not be Invoiced.)

FEDERAL EXCISE TAX. The City of Los Angeles Harbor Department is exempt from payment of Federal Excise Taxes, and will furnish vendor with a Tax Exemption Certificate. **PRICING NOT TO INCLUDE ANY FEDERAL EXCISE TAX.**

TAXPAYER IDENTIFICATION NUMBER. Contractor declares that it has an authorized Taxpayer Identification Number (TIN), which must be indicated on all invoices. No payments will be made under this agreement without a valid TIN number.

WITHHOLDING REQUIREMENTS. The State of California Franchise Tax Board (FTB) requires that the City of Los Angeles Harbor Department withhold income taxes from payments to out-of-state vendors for services performed within California unless the vendor submits one of the required forms listed below. The tax withholding rate is seven percent (7%) of payments subject to withholding.

This requirement applies to vendors whose legal address (as indicated on their IRS W-9 Form), or payment address (as indicated on this Request for Bid/Quote), is outside of California. **Should either of these two situations apply to your company, please attach one of the following forms to your bid** in order to help the Harbor Department clarify your nonresident tax withholding status:

- Form 590, *Withholding Exemption Certificate*, certifying exemption from the withholding requirement.
- Form 587, *Nonresident Income Allocation Worksheet*, which allocates the expected income under the City contract for work completed within and outside of California.
- Notice from the CA Franchise Tax Board (CAFTB) that a withholding waiver was authorized (you must first file CA Form 588, *Nonresident Withholding Waiver Request* to the CAFTB).
- Notice from CAFTB that a reduced withholding request was authorized (you must first file CA Form 589 *Nonresident Reduced Withholding Request* to CAFTB).

Further information regarding this requirement may be found here:

<https://www.ftb.ca.gov/pay/withholding/withholding-on-nonresidents.html>

Please Check One:

Both Bidder's Legal Address and Remittance Address are located within the State of California - Withholding Forms Not Required.

Withholding Forms Attached

Withholding Forms On-File

REQUEST FOR BIDS

CITY OF LOS ANGELES
HARBOR DEPARTMENT

NO. F-1210
(SHOW THIS NUMBER ON ENVELOPE)

BUSINESS TAX REGISTRATION CERTIFICATE (BTRC). In accordance with the City of Los Angeles Municipal Code, a Business Tax Registration Certificate may be required of persons engaged in business activity within the City. The Office of Finance, Tax and Permit Division, (213) 473-5901, has sole authority in determining a firm's tax requirements and in issuing Business Tax Registration Certificates or Business Tax Exemption Numbers. Accordingly, firm's current Business Tax Registration Certificate or Business Tax Exemption Number must be clearly shown on all invoices submitted for payment. Bidder, in submitting this bid, acknowledges and accepts the above requirements and recognizes that no invoice will be processed for payment without inclusion of the Business Tax Registration Certificate or Business Tax Exemption Number. **New vendors will be required to supply their BTRC/VRN Number upon award and prior to payment.**

BTRC Number: 0003156855

VENDOR PAYMENT. Please note: Vendor name and address must be submitted exactly as they will appear on the invoice(s). **Please provide a copy of your firm's IRS Form W-9 with your bid.** If invoice remit to (remittance) name and address are different from the bid name and address, please indicate:

COMPANY: CAVOTEC USA INC.

500 S. Main Street, Bldg. #1, Suite 109

REMIT TO: ADDRESS:

Mooresville, NC 28115

AR EMAIL: ar.us@cavotec.com

Invoices submitted for payment where the invoice name and address do not match the name and address as they appear on the Purchase Order, or as indicated in the space above, will not be processed and will be returned to the vendor.

GENERAL CLAUSES – LAW, CHARTER, ADMINISTRATIVE CODE

NEW AND UNUSED, VEHICLE. The vehicle and/or equipment furnished shall be new and unused, current model, with standard factory fittings, trim, and accessories unless otherwise noted. Said vehicle and/or equipment shall not have been used for any other prior service or as a demonstrator.

VEHICLE CODE. All applicable vehicles shall conform to the California Vehicle Code and all other governing requirements.

GVWR. All applicable vehicles shall meet the Federal GVWR rating and all components shall have corresponding GVWR ratings. Any vehicle that requires a larger wheel and tire size on the rear axle shall have an equal size wheel and tire on the front axles, unless otherwise specified.

REQUEST FOR BIDS

CITY OF LOS ANGELES
HARBOR DEPARTMENT

NO. F-1210
(SHOW THIS NUMBER ON ENVELOPE)

LICENSES. When applicable, the vendor shall make the necessary applications and complete all transfer papers, including applying for exempt license. He/She shall furnish the Director of Port Construction and Maintenance, or his/her designated representative, evidence of having applied for license at time vehicle is delivered. The registered owner shall be shown exactly as outlined below on all forms where the registered owner is listed, (using abbreviations exactly as shown):

HARBOR DEPARTMENT
CITY OF LOS ANGELES
500 Pier A St.
Wilmington, CA 90744-6433

DEALER SERVICE. All equipment furnished shall be completely serviced locally by the vendor prior to delivery. It shall be ready for operation when delivered. Any further servicing by the vendor will not be required except in connection with repairs or adjustments covered by the Manufacturer's or Dealer's warranty.

COMPLIANCE WITH LAWS. Vendor shall comply with all applicable Ordinances, laws, Rules and Regulations of the City and of any County, State or Federal Government, or subdivision thereof.

DEFAULT BY SUPPLIER. In case of default by Vendor, the Department reserves the right to procure the articles or services from other sources and to hold the vendor responsible for any excess costs occasioned to the Department thereby.

SAFETY APPROVAL. Electrical items listed herein shall have UNDERWRITER'S LABORATORY OR LOS ANGELES CITY ELECTRICAL TESTING LABORATORY approval and meet all current OSHA and CAL-OSHA requirements, where applicable.

SMALL BUSINESS, MINORITY-OWNED, WOMEN-OWNED, DISABLED VETERAN-OWNED AND ALL OTHER BUSINESS ENTERPRISES. It is the policy of the Department to provide Small Business, Minority-Owned, Women-Owned, Disabled Veteran-Owned and all Other Business Enterprises (SBE/MBE/WBE/DVBE/OBE) an equal opportunity to participate in the performance of all Department contracts. Bidders are encouraged to continue assisting the Department in implementing this policy by taking all reasonable steps to ensure that all available business enterprises, including SBEs, MBEs, WBEs, DVBEs, and OBEs, have an equal opportunity to compete for and participate in Department contracts.

LOCAL BUSINESS PREFERENCE PROGRAM.

The Harbor Department is committed to maximizing opportunities for local and regional businesses, as well as encouraging local and regional businesses to locate and operate within the Southern California region. It is the policy of the Harbor Department to support an increase in local and regional jobs. The Harbor Department's Local Business Preference Program (LBPP) aims to benefit the Southern California region by increasing jobs and expenditures within the local and regional private sector.

Vendors who qualify as a Local Business Enterprise (LBE) will receive an 8% preference on any bid for goods, materials, supplies, and related services valued in excess of \$150,000. The preference will be applied by calculating the bidder's price at 8% less than the quoted price. The Harbor Department will

REQUEST FOR BIDS

CITY OF LOS ANGELES
HARBOR DEPARTMENT

NO. F-1210
(SHOW THIS NUMBER ON ENVELOPE)

use the applied preference for bid tabulation only. Actual amount paid to the lowest bidder will be the *price quoted by the lowest bidder meeting specifications.*

The Harbor Department defines a LBE as:

(a) A business headquartered within Los Angeles, Orange, Riverside, San Bernardino, or Ventura Counties. Headquartered shall mean that the business physically conducts and manages all of its operations from a location in the above-named counties; or

(b) A business that has at least 50 full-time employees, or 25 full-time employees for specialty marine contracting firms, working in Los Angeles, Orange, Riverside, San Bernardino, or Ventura Counties.

In order for Harbor Department staff to determine the appropriate LBE preference, Bidder shall complete, sign, notarize and submit the attached Affidavit and Bidder Description Form. The Affidavit and Bidder Description Form will signify the LBE status of the Bidder and subcontractors.

In the event of Bidder's noncompliance during the performance of the Contract, Bidder shall be considered in material breach of contract. In addition to any other remedy available to City under this Contract or by operation of law, the City may withhold invoice payments to Bidder until noncompliance is corrected, and assess the costs of City's audit of books and records of Bidder and its subcontractors. In the event the Bidder falsifies or misrepresents information contained in any form or other willful noncompliance as determined by City, City may disqualify the Bidder from participation in City contracts for a period of up to five (5) years.

SWEAT-FREE PROCUREMENT POLICY

The Board of Harbor Commissioners of the City of Los Angeles adopted Resolution No. 6455 on October 19, 2006, agreeing to adopt provisions of Los Angeles City Ordinance 176,291, relating to Sweat-Free Procurement, Section 10.43 et seq. of the Los Angeles Administrative Code, as a policy of the Harbor Department. Contractor shall comply with the policy wherever applicable. Violation of the policy shall entitle the City to terminate any Agreement with Contractor and pursue any and all other legal remedies that may be available.

EQUAL BENEFITS POLICY. The Board of Harbor Commissioner of the City of Los Angeles adopted Resolution No. 6328 on January 12, 2005, agreeing to adopt the provisions of Los Angeles City Ordinance 172,908, as amended, relating to Equal Benefits (Section 10.8.2 et seq. of the Los Angeles Administrative Code) as a policy of the Harbor Department. Bidder shall comply with the policy whenever applicable. Violation of the policy shall entitle the City to terminate any agreement with Bidder and pursue any or all other legal remedies that may be available.

ETHICS. Persons who submit a response to this solicitation (bidders) are subject to Charter section 470(c)(12) and related ordinances. As a result, bidders may not make campaign contributions to and or engage in fundraising for certain elected City officials or candidates for elected City office from the time they submit the response until either the contract is approved or, for successful bidders, 12 months after

REQUEST FOR BIDS

CITY OF LOS ANGELES
HARBOR DEPARTMENT

NO. F-1210
(SHOW THIS NUMBER ON ENVELOPE)

they submit the response until either the contract is approved or, for successful bidders, 12 months after the contract is signed. The bidder's principals and subcontractors performing \$100,000 or more in work on the contract, as well as the principals of those subcontractors, are also subject to the same limitations on campaign contributions and fundraising.

Bidders must submit CEC Forms 50 and 55, attached, to the awarding authority at the same time the response is submitted. The forms require bidders to identify their principals, their subcontractors performing \$100,000 or more in work on the contract, and the principals of those subcontractors. Bidders must also notify their principals and subcontractors in writing of the restrictions and include the notice in contracts with subcontractors. Responses submitted without completed CEC Forms 50 and 55 shall be deemed nonresponsive. Bidders who fail to comply with City law may be subject to penalties, termination of contract, and debarment. Additional information regarding these restrictions and requirements may be obtained from the City Ethics Commission at (213) 978-1960 or ethics.lacity.org.

IRAN CONTRACTING ACT OF 2010. The California Legislature adopted the Iran Contracting Act of 2010 to respond to policies of Iran in a uniform fashion (PCC § 2201(q)). The Iran Contracting Act prohibits bidders engaged in investment activities in Iran from submitting bids for, or entering into or renewing contracts with public entities for goods and services of one million dollars (\$1,000,000) or more (PCC § 2203(a)). In accordance with California Public Contract Code Sections 2200-2208, all bidders submitting bids for, entering into, or renewing contracts with the Harbor Department for goods and services estimated at \$1,000,000 or more are required to complete, sign, and submit the Iran Contracting Act of 2010 Compliance Affidavit (See Attachment B).

REGIONAL ALLIANCE MARKETPLACE FOR PROCUREMENT (RAMP). **PRIOR TO BEING AWARDED A CONTRACT** with the Harbor Department, all vendors must be registered on the City's Contracts Management and Opportunities Database, Regional Alliance Marketplace for Procurement (RAMP), at <http://www.RAMPLA.org>.

Respondents are advised, pursuant to [Executive Directive 35](#), if a bidder is selected and awarded a contract, and if the vendor is a for-profit company or corporation, the vendor shall, within 30 days of the effective date of the contract and on an annual basis thereafter (i.e., within 30 days of the anniversary of the effective date of the contract), report the following information to City via the Regional Alliance Marketplace for Procurement ("RAMP") or via another method specified by City: vendor's and any subcontractor's annual revenue, number of employees, location, industry, race/ethnicity and gender of majority owner ("contractor/subcontractor Information"). On an annual basis, the vendor shall further request that any subcontractor input or update its business profile, including the vendor/subcontractor information, on RAMP or via another method prescribed by City.

VENDOR'S RAMP ID Number(s): 104216

REQUEST FOR BIDS

CITY OF LOS ANGELES
HARBOR DEPARTMENT

NO. F-1210
(SHOW THIS NUMBER ON ENVELOPE)

GENERAL CONDITIONS READ CAREFULLY

1. **FORM OF BID AND SIGNATURE.** The Bid must be made on this form only, and is limited to the Terms and Conditions contained herein, unless expressly agreed otherwise in writing by the City. No telephonic, facsimile, or electronic bid is acceptable, unless otherwise indicated. Bid should be enclosed in a sealed envelope, showing the Bid No. in the lower left corner, and addressed to the Port of Los Angeles Contracts and Purchasing Division, 500 Pier "A" Street, Wilmington, CA 90744. Bids must be signed with the firm's corporate name or DBA and by a responsible officer or authorized employee. In case of error in extension of prices, unit price will govern. All prices must be firm unless the specification provides for adjustment.
2. **TAXES:** Do not include any Sales or Federal Excise Tax in prices unless the specifications specifically require that they be included. Sales tax will be added by the City at time of award. The City will furnish Federal Excise Tax Exemption Certificate to Supplier. Any other taxes must be included in bid prices.
3. **SPECIFICATION CHANGES.** Contractor may request in writing that specifications be modified if its provisions restrict Contractor from bidding. Such request must be received by the Director of Purchasing at least five (5) working days before bid opening date. All Contractors will be notified by Addendum of any approved changes in the specifications.
4. **BRAND NAMES AND SPECIFICATIONS.** The detailed specifications and/or brand name references are descriptive and indicate quality, design, and construction of items required. Offers will be considered to supply articles substantially the same as those described therein but with minor variations. Contractor must describe variations in their Bid.
5. **AWARD OF CONTRACT.** Bid shall be subject to acceptance by the City for a period of three (3) months unless a lesser period is prescribed in the quotation by the Contractor. The City may make combined award of all items complete to one Contractor or may award separate items to various Contractors. Contractors may submit alternate prices, a lump sum or a discount conditional on receiving an award for two or more items. The right is reserved to reject any, or all, bids and to waive informality in bids.
6. **PURCHASE AGREEMENT.** A copy of the Bid, Specifications and General Conditions will remain on file in the Purchasing Office. All material or services supplied by the Contractor shall conform to the applicable requirements of the City Charter, City Ordinances, and all applicable State and Federal Laws, as well as conforming to the Specifications, Terms and Conditions contained herein.
7. **PRICE GUARANTEE.** If during the term of any agreement awarded pursuant to this Bid, the supplier sells the same materials or services under similar quantity and delivery conditions, at prices below those stated herein, such lower prices are to immediately be extended to the City.
8. **DEFAULT BY SUPPLIER.** In case of default by supplier, the City reserves the right to procure the articles or services from other sources and to hold the supplier responsible for any excess costs incurred by the City.
9. **DELIVERY:** If delivery of the commodity or service cannot be made exactly as specified and at the price shown, notify the Director of Contracts and Purchasing immediately. Do not make delivery without his approval. Any correspondence, other than invoices, relating to this order must be sent to the Director of Contracts and Purchasing.
10. **INSPECTION:** All materials furnished on this order will be subject to test and inspection and, if rejected, will be held subject to order of shipper and subject to accrued charges.
11. **INVOICING:** The point of free delivery, terms, contract number, name and address of department must appear on all invoices.

All materials must be marked and tagged with the Contract number and be accompanied by packing list in detail. Material must be packed and shipped in conformity with tariff or classification requirements.

Prices on the contract include delivery to the division within building unless otherwise specified on the contract.

Prepaid charges for transportation must be accompanied by original expense bill marked paid and is not subject to transportation tax, due to the exemption permitted municipalities as indicated.

Materials shall be listed separately on invoices covering repairs or installation service.

The Harbor Department will not be responsible for services, materials, or supplies furnished without prior authorization from the Director of Contracts and Purchasing.

This contract must not be assigned or transferred to anyone without the written approval of the Director of Contracts and Purchasing.

Discount period to be computed from date of receipt of invoice, or complete acceptance of goods or services, whichever is the later date.

In case of delay of payment beyond 30 days after acceptance of goods or services or date of invoice, whichever is later, please write the Harbor Department Accounting Section giving the contract number, stating to which division and on what date delivery was made.

Harbor Department may pay on partial deliveries, but right is reserved by the Director of Contracts and Purchasing to require complete delivery before payment.
12. **TIME AND MATERIALS WITH NO FIXED FEES: ALL INVOICES WITH PAYMENTS FOR TIME AND MATERIALS MUST BE SUPPORTED / BACKED UP BY TIME SHEETS.**

NOTE: THOSE INVOICES WITH FIXED FEE RATES DO NOT REQUIRE TIME SHEETS.
13. **CITY OF LOS ANGELES MUNICIPAL CODE:** All items must meet the requirements of the City of Los Angeles Municipal Code.
14. **PAYMENTS.** Payment terms are NET 30 days unless Contractor quotes otherwise. Cash discounts allowing less than 20 days or 20th Proxima will not be considered by the City when evaluating Bids. All Cash Discounts are computed from the date of delivery in full or completion and acceptance of the work or material, or from date of receipt of invoice, whichever is latest. Partial payments may be made by the City on delivery and acceptance of goods and on receipt of Contractor's invoice. Invoices must be submitted as specified on the Purchase Order or Notice to Proceed.
15. **ASSIGNMENT.** The supplier shall not assign or transfer by operation of law any obligation without the prior written consent of the Director of Contracts and Purchasing.
16. **NONDISCRIMINATION.** During the performance of this contract, the Contractor shall not discriminate in employment practices against any employee or applicant for employment because of the employee's race, religion, national origin, ancestry, sex, sexual orientation, age, disability, marital status, domestic partner status or medical condition, in accordance with L.A. Adm. Code Sections 10.8 to 10.13, whose provisions are incorporated herein. All subcontracts awarded under any such contract shall contain a like nondiscrimination provision.
17. **SAFETY APPROVAL.** Articles supplied under this contract will not be accepted unless they comply with current safety regulations of the City Department of Building and Safety, U.L., the Safety Orders of the California Division of Occupation Safety and Health (CalOSHA) and OSHA requirements.
18. **PREVAILING WAGES.** Where labor is required for public work as a part of this contract, pursuant to the provisions of the Labor Code of the State of California, Contractor shall pay no less than the general prevailing wages for the area as determined by the Director of the Department of Industrial Relations, State of

REQUEST FOR BIDS

**CITY OF LOS ANGELES
HARBOR DEPARTMENT**

NO. F-1210
(SHOW THIS NUMBER ON ENVELOPE)

California. Copy of wage schedule is obtainable from the Office of the Board of Public Works, City Hall, Los Angeles.

19. **CONTRACTOR'S LIABILITY.** The Contractor agrees to, at all times, relieve, protect, save harmless, and fully indemnify the City of Los Angeles, its officers, agents and employees from any and all liability whatsoever that may arise or be claimed by reason of any acts of said Contractor, Contractor's employees and agents, in connection with the work to be performed under the contract.
20. **PATENT RIGHTS.** The person, firm, or corporation, upon whom this order is drawn, does, in case the materials or supplies to be furnished are covered wholly or in part by U.S. Letters Patent, by the acceptance of this order agrees to indemnify and hold the City of Los Angeles harmless from any and all injuries or damage which the City may sustain by reason of the sale to or use by it of such materials or supplies and arising out of the alleged or actual infringement of said letters patent.
21. **LEGAL JUSTIFICATION.** This agreement shall be deemed entered into in Los Angeles, California, and shall be governed and construed in accordance with the laws of the State of California.
22. **TERMINATION FOR NON-APPROPRIATION.** The Harbor Department of the City of Los Angeles' (City's) obligation to pay any amount hereunder, for any City fiscal year purpose. The City's fiscal year ends on June 30th of each calendar year. Accordingly, anything to the contrary notwithstanding, the City may terminate this contract and future monetary obligations hereunder as of the end of any fiscal year.
23. **CANCELLATION.** The contract may be terminated in whole or in part by the Harbor Department of the City of Los Angeles (City) for its convenience, without penalty, provided that the Contractor is given not less than 30 days written notice (delivered by certified mail, return receipt requested) of the intent to terminate. The City will pay for that portion of the orders fulfilled or work performed. The City has the right to cancel the contract for cause at any time.

THE END

No. 285 Rev. 07/15-116



We connect the future.

Limited Power of Attorney

This Power of Attorney (the « POA ») is made this 10th day of June 2024 (the "Effective Date").

1. Parties

BY

Patrick Baudin an individual with primary residence 600 Victoria avenue, Westmount, H3Y 2R9, Quebec (Canada) and Director of Cavotec USA Inc a corporation existing and organized under the laws of the United States located 500 S Main St bldg 1 suite 109, Mooresville, NC 28115, United States;

AND

Matt Pozsik an individual with primary residence 8844 SW 58th Street Rd, Ocala, Florida 34481 (United States) and Director of Cavotec USA Inc a corporation existing and organized under the laws of the United States located 500 S Main St bldg 1 suite 109, Mooresville, NC 28115, United States

Matt Pozsik and Patrick Baudin being hereinafter to as the "Principals" or "we"

TO

Alfredo Rivas (the "Attorney") an individual with primary residence at 1516 Sandpiper Circle, Weston, Florida 33327 (United States), employee of Cavotec USA Inc a corporation existing and organized under the laws of the United States located at 500 S Main St Building 1 Suite 109, Mooresville, NC 28115, United States;

Principals and Attorney being hereinafter referred to individually as a Party and together as the Parties

2. Recitals

WHEREAS Cavotec USA Inc would like to participate in **Bid No. F-1210 to fulfil the one-time requirement for one (1) Cavotec PowerMove Mini Towable Shore Power Connection System Unit** (the "Bid") to **the Los Angeles Harbor Department** for their project located in **Port of Los Angeles** (the "Bid");

WHEREAS in order to participate in the Bid the Attorney needs to be allowed to prepare and sign Bid documents on behalf of Cavotec USA Inc and as described below;

Whereas the Parties acknowledge that the Bid closes on Friday 14th of June at 2 PM California Time;

WHEREAS the Principals in their quality of Directors of Cavotec USA Inc agrees and wishes hereby to delegate their powers, as described below, as vested to them by Cavotec USA Inc to the Attorney for the validity of this POA and agree to ratify all acts, deeds and things lawfully done by said Attorney pursuant to this POA and that all acts, deeds and things done by Attorney shall always be deemed to have been done by the Principals;

Handwritten initials in blue ink, appearing to be 'B' and 'P'.



We connect the future.

Whereas the Parties wish the content of this POA to be acknowledged and the grant of the Principals' powers to the Attorney be made valid from the Effective Date;

NOW THEREFORE the Parties agrees as follows:

3. Terms

3.1 Scope of Power

Principals authorizes Attorney to prepare, collect, submit and sign any Bid documents in order for Cavotec USA Inc to participate to said Bid.

In addition to the above Attorney is granted power and authority on behalf of the Principals for the following purposes:

- To do in our name and on our behalf, all such acts deeds and things that may be necessary in connection with or incidental to our Bid for the project envisaging the selling and commission of one (1) **PowerMove Mini Towable Shore Power Connection System Unit** to the **Los Angeles Harbor Department** and providing information/response to **to any person in as Attorney may deemed necessary** or;
- Representing us in all matters before the **Los Angeles Harbor Department** and generally dealing with **any person employed by said Harbor Department** in connection with our Bid for the project described herein.

3.2 Duration and Validity

This POA is valid and comes in full effect from the Effective Date and shall be terminated the 15th of June 2024 at midnight Florida Time at which time it will cease to deploy any effect.

This POA may be revoked by the any of the Principals at any given time by simple written notice.

3.3 Governing Law and Jurisdiction

This POA and all the transactions contemplated hereby shall be governed by, construed and interpreted in accordance with Swiss Law to the exclusion of any other law. Any action arising out of or relating to this POA will be brought on int the competent court of Lugano, Switzerland.

The Principals

A blue ink signature of Patrick Baudin, consisting of a stylized 'P' and 'B' followed by a horizontal line.

Patrick Baudin

A blue ink signature of Matt Pozsik, consisting of a stylized 'M' and 'P' followed by a horizontal line.

Matt Pozsik

The Attorney

A blue ink signature of Alfredo Rivas, consisting of a stylized 'A' and 'R' followed by a horizontal line.

Alfredo Rivas

Québec 
Permis de conduire

B3507-130471-03 



1 **BAUDIN**

2 **PATRICK**

3 Date de naissance (A-M-J) : **1971-04-13**

4 **600 AV VICTORIA**
WESTMOUNT
(QC) H3Y 2R9

5 Sexe : **M**

6 Classe(s) : **5**

7 Cond. : **Aucune** 8 Taille (cm) : **180**

9 Mentions : **Aucune** 10 Yeux : **BLEU**

11 N° de référence : **PEQY855KK**

12 Valable (à) : **2020-04-03** 13 Expire (le) : **2027-04-13**

Paiement exigé chaque année à votre date anniversaire de naissance





CLASSE(S): Véhicule automobile de moins de 4 500 kg et habitation motorisée.

Apposer l'autocollant de votre nouvelle adresse.

Renseignements : 1 800 361-7620

Validité d'un permis : 1 800 565-1212 (frais exigés)

Société de l'assurance automobile

Québec 

saq.gouv.qc.ca (2015-08)



Florida

DRIVER LICENSE



16 DLN P220-556-71-149-0 CLASS E
 POZSIK
 MATTHEW ROBERT
 8844 SW 58TH STREET RD
 OCALA, FL 34481
 1 DOB 04/29/1971 15 SEX M
 10 EXP 04/29/2031 16 HGT 5'-09"
 12 REST B 9a END NONE

SAFE DRIVER
 4a DS 08/11/2022
 5 DD 1652304250648
 6P PLACED 04/25/2023

Operation of a motor vehicle constitutes consent to any sobriety test required by law.



Handwritten signature in blue ink



REPLACEMENT LICENSE REQUIRED WITHIN 30 DAYS
 OF ADDRESS OR NAME CHANGE.
 WWW.FLHSMV.GOV

CLASS: E - Any non-commercial veh with a GVWR < 26,001 lbs.
 or any RV
 REST: B-Corr License
 END: None



of Florida
 retains all
 property interest
 042971
 Rev
 03/01/2020



DL2020

**MINUTES OF ACTION OF BOARD OF DIRECTORS
CAVOTEC USA INC.
ACCEPTANCE OF RESIGNATION AND
APPOINTMENT OF OFFICERS
09 MARCH 2023**

The following action is taken by the Board of Directors of Cavotec USA Inc., a Delaware corporation (the "Company"), by written consent, without a meeting as of the date set forth below, pursuant to Section 141(f) of the Delaware General Corporation Law permitting such action to be taken.

Acceptance of Resignation

The resignation of Glenn Withers as a director and officer of the Company is accepted.

Appointment of Director

Pursuant to Section 3.5 of the Company's Bylaws, Joakim Wahlquist is appointed as a director of the Company to fill the vacancy created by Glenn Withers' resignation.

Confirmation of Officers

Patrick Baudin is confirmed as President of the Company, effective for the ensuing year.

Jim Andriotis is confirmed as Vice President of the Company, effective for the ensuing year.

Matt Pozsik is confirmed as Secretary and Treasurer of the Company, effective for the ensuing year.

Dated: 09 March 2023

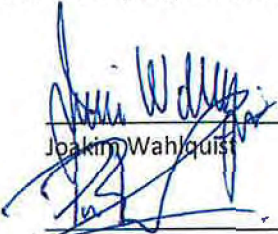

Joakim Wahlquist

Patrick Baudin

Consent of Sole Stockholder

Pursuant to Section 2.11 of the Company's Bylaws, the undersigned, being the sole stockholder of the Company, consents to the foregoing actions of the Board of Directors as of the 9th day of March 2023.

Cavotec SA
a Swiss corporation

By 

David Pagels, Group Chief Executive Officer

By 

Vanessa Tisci, Group General Counsel

CAVOTEC USA INC.

RESIGNATION OF DIRECTOR AND OFFICER

To Shareholders and Board of Directors:

The undersigned, Glenn Withers, hereby resigns as a director and as an officer of Cavotec USA Inc., a Delaware corporation, effective 09 March 2023.

Dated: 09 March 2023



Glenn Withers

Florida DRIVER LICENSE 

R120-001-64-224-0 **CLASS: E**

RIVAS
ALFREDO ANTONIO
1516 SANDPIPER CIR
WESTON, FL 33327



DOB: 06/24/1964 **SEX: M**
EXP: 06/24/2029 **HGT: 5'-06"**
REST: NONE **END: NONE**

SAFE DRIVER **POHNR**

ISS: 01/17/2020
SCD: R022001170298

[Signature]

Operation of a motor vehicle constitutes consent to any sobriety test required by law.





The State of Florida retains all property rights herein.
 062464
 Rev. 05/01/2019



CLASS: E - Any non-commercial veh with a GVWR < 26,001 lbs. or any RV
REST: None
END: None

REPLACEMENT LICENSE REQUIRED WITHIN 30 DAYS OF ADDRESS OR NAME CHANGE.
WWW.FLHSMV.GOV



01/17/2020
 12001170298



Request for Taxpayer Identification Number and Certification

**Give Form to the
 requester. Do not
 send to the IRS.**

▶ Go to www.irs.gov/FormW9 for instructions and the latest information.

Print or type. See Specific Instructions on page 3.	1 Name (as shown on your income tax return). Name is required on this line; do not leave this line blank. Cavotec USA Inc		
	2 Business name/disregarded entity name, if different from above		
	3 Check appropriate box for federal tax classification of the person whose name is entered on line 1. Check only one of the following seven boxes.		4 Exemptions (codes apply only to certain entities, not individuals; see instructions on page 3): Exempt payee code (if any) _____ Exemption from FATCA reporting code (if any) _____ <small>(Applies to accounts maintained outside the U.S.)</small>
	<input type="checkbox"/> Individual/sole proprietor or single-member LLC <input type="checkbox"/> C Corporation <input checked="" type="checkbox"/> S Corporation <input type="checkbox"/> Partnership <input type="checkbox"/> Trust/estate		
	<input type="checkbox"/> Limited liability company. Enter the tax classification (C=C corporation, S=S corporation, P=Partnership) ▶ _____ Note: Check the appropriate box in the line above for the tax classification of the single-member owner. Do not check LLC if the LLC is classified as a single-member LLC that is disregarded from the owner unless the owner of the LLC is another LLC that is not disregarded from the owner for U.S. federal tax purposes. Otherwise, a single-member LLC that is disregarded from the owner should check the appropriate box for the tax classification of its owner.		
	<input type="checkbox"/> Other (see instructions) ▶ _____		
	5 Address (number, street, and apt. or suite no.) See instructions. 500 S Main St, Suite 109		Requester's name and address (optional)
6 City, state, and ZIP code Mooreville, NC 28115			
7 List account number(s) here (optional)			

Part I Taxpayer Identification Number (TIN)

Enter your TIN in the appropriate box. The TIN provided must match the name given on line 1 to avoid backup withholding. For individuals, this is generally your social security number (SSN). However, for a resident alien, sole proprietor, or disregarded entity, see the instructions for Part I, later. For other entities, it is your employer identification number (EIN). If you do not have a number, see *How to get a TIN*, later.

Note: If the account is in more than one name, see the instructions for line 1. Also see *What Name and Number To Give the Requester* for guidelines on whose number to enter.

Social security number									
or									
Employer identification number									
3	5		2	3	3	1	1	4	0

Part II Certification

Under penalties of perjury, I certify that:

1. The number shown on this form is my correct taxpayer identification number (or I am waiting for a number to be issued to me); and
2. I am not subject to backup withholding because: (a) I am exempt from backup withholding, or (b) I have not been notified by the Internal Revenue Service (IRS) that I am subject to backup withholding as a result of a failure to report all interest or dividends, or (c) the IRS has notified me that I am no longer subject to backup withholding; and
3. I am a U.S. citizen or other U.S. person (defined below); and
4. The FATCA code(s) entered on this form (if any) indicating that I am exempt from FATCA reporting is correct.

Certification instructions. You must cross out item 2 above if you have been notified by the IRS that you are currently subject to backup withholding because you have failed to report all interest and dividends on your tax return. For real estate transactions, item 2 does not apply. For mortgage interest paid, acquisition or abandonment of secured property, cancellation of debt, contributions to an individual retirement arrangement (IRA), and generally, payments other than interest and dividends, you are not required to sign the certification, but you must provide your correct TIN. See the instructions for Part II, later.

Sign Here	Signature of U.S. person ▶ <i>K Ciarsien</i>	Date ▶ 2/13/2024
------------------	--	------------------

General Instructions

Section references are to the Internal Revenue Code unless otherwise noted.

Future developments. For the latest information about developments related to Form W-9 and its instructions, such as legislation enacted after they were published, go to www.irs.gov/FormW9.

Purpose of Form

An individual or entity (Form W-9 requester) who is required to file an information return with the IRS must obtain your correct taxpayer identification number (TIN) which may be your social security number (SSN), individual taxpayer identification number (ITIN), adoption taxpayer identification number (ATIN), or employer identification number (EIN), to report on an information return the amount paid to you, or other amount reportable on an information return. Examples of information returns include, but are not limited to, the following.

- Form 1099-INT (interest earned or paid)

- Form 1099-DIV (dividends, including those from stocks or mutual funds)
- Form 1099-MISC (various types of income, prizes, awards, or gross proceeds)
- Form 1099-B (stock or mutual fund sales and certain other transactions by brokers)
- Form 1099-S (proceeds from real estate transactions)
- Form 1099-K (merchant card and third party network transactions)
- Form 1098 (home mortgage interest), 1098-E (student loan interest), 1098-T (tuition)
- Form 1099-C (canceled debt)
- Form 1099-A (acquisition or abandonment of secured property)

Use Form W-9 only if you are a U.S. person (including a resident alien), to provide your correct TIN.

If you do not return Form W-9 to the requester with a TIN, you might be subject to backup withholding. See *What is backup withholding*, later.

LOCAL BUSINESS PREFERENCE PROGRAM

The Harbor Department is committed to maximizing opportunities for local and regional businesses, as well as encouraging local and regional businesses to locate and operate within the Southern California region. It is the policy of the Harbor Department to support an increase in local and regional jobs. The Harbor Department's Local Business Preference Program (LBPP) aims to benefit the Southern California region by increasing jobs and expenditures within the local and regional private sector.

Vendors who qualify as a Local Business Enterprise (LBE) will receive an 8% preference on any bid for goods, materials, supplies, and related services valued in excess of \$150,000. The preference will be applied by calculating the bidder's price at 8% less than the quoted price. The Harbor Department will use the applied preference for bid tabulation only. The actual amount paid to the lowest bidder will be the price quoted by the lowest bidder meeting specifications.

The Harbor Department defines an LBE as:

- (a) A business headquartered within Los Angeles, Orange, Riverside, San Bernardino, or Ventura Counties. Headquartered shall mean that the business physically conducts and manages all of its operations from a location in the above-named counties; or
- (b) A business that has at least 50 full-time employees, or 25 full-time employees for specialty marine contracting firms, working in Los Angeles, Orange, Riverside, San Bernardino, or Ventura Counties.

In order for Harbor Department staff to determine the appropriate LBE preference, Vendor shall complete, sign, notarize and submit the attached Affidavit. The Affidavit will signify the LBE status of the Vendor.

In the event of Vendor's noncompliance during the performance of the Contract, Vendor shall be considered in material breach of contract. In addition to any other remedy available to City under this Contract or by operation of law, the City may withhold invoice payments to Vendor until noncompliance is corrected, and assess the costs of City's audit of books and records of Vendor. In the event the Vendor falsifies or misrepresents information contained in any form or other willful noncompliance as determined by City, City may disqualify the Vendor from participation in City contracts for a period of up to five (5) years.

AFFIDAVIT OF COMPANY STATUS

"The undersigned declares under penalty of perjury pursuant to the laws of the State of California that the following information is true and correct and includes all material information necessary to identify and explain the operations of

CAVOTEC USA INC.

Name of Firm

as well as the ownership and location thereof. Further, the undersigned agrees to provide complete and accurate information regarding ownership in the named firm, any proposed changes of the ownership and to permit the audit and examination of firm ownership documents in association with this contract."

Local Business Preference Program: Please indicate the Local Business Enterprise status of your company. Only one box must be checked:

LBE Non-LBE

- A Local Business Enterprise (LBE) is: (a) a business headquartered within Los Angeles, Orange, Riverside, San Bernardino, or Ventura Counties; or (b) a business that has at least 50 full-time employees, or 25 full-time employees for specialty marine contracting firms, working in Los Angeles, Orange, Riverside, San Bernardino, or Ventura Counties. "Headquartered" shall mean that the business physically conducts and manages all of its operations from a location in the above-named counties.
- A Non-LBE is any business that does not meet the definition of an LBE.

Signature: _____



Title: POA / Regional Sales Director Americas

Printed Name: Alfredo Rivas

Date Signed: 6/13/2024

This form must be submitted with your bid or proposal to the City department that is awarding the contract noted below. If you have questions about this form, please contact the Ethics Commission at (213) 978-1960.

Original Filing **Amendment:** Date of Signed Original _____ Date of Last Amendment _____

Reference Number (Bid, Contract, or RAMP) F-1210	Awarding Authority (Department awarding the contract) HARBOR
Bidder Name CAVOTEC USA INC.	
Address 500 South Main Street, Bldg #1, Suite 109, Mooresville, NC 28115	
Email Address alfredo.rivas@cavotec.com	Phone Number (704) 242-3678 / 873-3009

Certification

I certify the following on my own behalf or on behalf of the entity named above, which I am authorized to represent:

A. I am applying for one of the following types of contracts with the City of Los Angeles:

1. A goods or services contract with a value of more than \$25,000 and a term of at least three months;
2. A construction contract with any value and duration;
3. A financial assistance contract, as defined in Los Angeles Administrative Code § 10.40.1(h), with a value of at least \$100,000 and a term of any duration; or
4. A public lease or license, as defined in Los Angeles Administrative Code § 10.40.1(i), with any value and duration.

B. I acknowledge and agree to comply with the disclosure requirements and prohibitions established in the Los Angeles Municipal Lobbying Ordinance if I qualify as a lobbying entity under Los Angeles Municipal Code § 48.02.

I certify under penalty of perjury under the laws of the City of Los Angeles and the state of California that the information in this form is true and complete.

Alfredo Rivas

Name
POA / Regional Sales Director Americas

Title

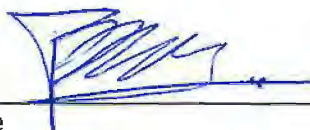

Signature
6/13/2024

Date

Prohibited Contributors (Bidders)

This form must be completed in its entirety and submitted with your bid or proposal to the City department that is awarding the contract. Failure to submit a completed form may affect your bid or proposal. If you have questions about this form, please contact the Ethics Commission at (213) 978-1960.

Original Filing **Amendment:** Date of Signed Original _____ Date of Last Amendment _____

Reference Number (Bid, Contract, or RAMP): F-1210 Date Bid Submitted: _____

Contract Description (Title of the RFP or City contract solicitation and description of the services to be provided):
TOWABLE SHORE POWER SYSTEM

Awarding Authority (Department awarding the contract): HARBOR

Bidder Name: CAVOTEC USA INC.

Bidder Address: 500 South Main Street, Bldg #1, Suite 109, Mooresville, NC 28115

Bidder Email Address: alfredo.rivas@cavotec.com Bidder Phone Number: (704) 242-3678 / 873-3009

Schedule Summary

Please complete all three of the following:

<p>1. SCHEDULE A – Bidder's Principals (check one) The bidder has one or more PRINCIPALS, as defined in LAMC § 49.7.35(A)(6). At least one principal is required for entities. (If you check "Yes", Schedule A is required.)</p>	<p>Yes <input checked="" type="checkbox"/></p>	<p>No <input type="checkbox"/></p>
<p>2. SCHEDULE B – Subcontractors and Their Principals (check one) The bidder has one or more SUBCONTRACTORS on this bid or proposal with subcontracts worth \$100,000 or more. (If you check "Yes", Schedule B is required.)</p>	<p>Yes <input type="checkbox"/></p>	<p>No <input checked="" type="checkbox"/></p>
<p>3. TOTAL NUMBER OF PAGES SUBMITTED (including this cover page): <u>2</u></p>		

Certification

I certify the following under penalty of perjury under the laws of the City of Los Angeles and the state of California:
A) I understand, will comply with, and have notified my principals and subcontractors of the requirements and restrictions in Los Angeles City Charter § 470(c)(12) and any related ordinances; B) I understand that I must amend this form within ten business days if any information changes; C) I am the bidder named above or I am authorized to represent the bidder named above, and my name appears below; and D) The information provided in this form is true and complete to the best of my knowledge and belief.

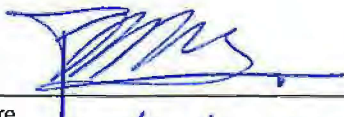
Alfredo Rivas 
Name Signature

POA / Regional Sales Director Americas 6/13/2024
Title Date

Schedule A - Bidder's Principals

Please identify the names and titles of all the bidder's principals (attach additional sheets if necessary). Principals include a bidder's board chair, president, chief executive officer, chief operating officer, and individuals who serve in the functional equivalent of one or more of those positions. Principals also include individuals who hold an ownership interest in the bidder of at least 20 percent and employees of the bidder who are authorized by the bid or proposal to represent the bidder before the City.

Name: Patrick Baudin Title: President
 Address: 600 Victoria Av, Wesmount, H3Y 2R9, Quebec, Canada

Name: Matt Pozsik Title: Secretary and Treasurer
 Address: 8844 SW 58th Street, Ocala, Florida 34481, United States of Americas

Name: Jim Andriotis Title: Vice President
 Address: 500 South Main Street, Bldg 1, #109, Mooresville, North Carolina 28115, United States of Americas

Name: _____ Title: _____
 Address: _____

Name: _____ Title: _____
 Address: _____

Name: _____ Title: _____
 Address: _____

Name: _____ Title: _____
 Address: _____

Name: _____ Title: _____
 Address: _____

Name: _____ Title: _____
 Address: _____

Check this box if additional Schedule A pages are attached.

SHOREPOWER | PowerMove



Technical Specification

1. SYSTEM DESCRIPTION 2

2. OPERATION DESCRIPTION 4

3. SCOPE OF SUPPLY 6

3.1 MOBILE STRUCTURE 7

3.2 5-MONOSPICAL CABLE REEL 7

 3.2.1 Drive Unit 7

 3.2.2 5-Monospiral drum 7

 3.2.3 Collector 7

 3.2.4 Motor 8

 3.2.5 Power and Neutral cables 8

 3.2.6 Plug Shore side 8

3.3 SIGNAL CABLE REEL 9

3.4 POWERMOVE AUXILIARY SUPPLY REEL 9

3.5 JIB CRANE 9

3.6 CRANE SHORE CONNECTION CABLE SET 9

3.7 POWERMOVE CONTROL CENTER 10

3.8 POWERMOVE REMOTE CONTROL 10

3.9 RECOMMENDED SPARE PARTS 10

4. DATASHEET 13

C	Revised spare parts	18 November 2022	DR	DR
B	Revised active cable length	15 May 2022	DR	DR
A	Issued for proposal	15 December 2021	DR	DR
Rev	Comment	Date	By	Approved

1. System description

Cavotec PowerMove (Mini) provide a mobile and flexible means to handle the cables necessary to connect electrically the cruise ships, docked in the Port, to the shore. PowerMove shall be designed to be compliance with requirement of "IEC 80005:1 Utility connections in port – Part 1: High Voltage Shore Connection (HVSC) Systems – General requirements" regarding safety of Cable Management System (CMS).



PowerMove connected in Los Angeles (in use from 2008)



PowerMove - mini connected in Los Angeles (in use from 2009)

The electrical connection to shore grid allows the ship to switch off its generators, thereby giving significant reductions in noise and air pollution. The cruise ships calling the Port are docked in different position and the position of the shore connection hatch (window in the ship for shore connection) along the berth can be different. The PowerMove shall be able to handle the shore connection cables between a fix points on the Berth (sockets outlet Junction Box - PowerFeed) and the Shore connection hatch location and furthermore, thanks to the use of a Jib crane (installed on the PowerMove itself), shall be able to pass the cables from the pier on board of ship.

The shore connection cables along the berth shall be protected (in accord to local regulations (not Cavotec scope). To correctly place the shore connection cables, the PowerMove shall be equipped with a multiple Monospiral cable reel and a cable guide.

The PowerMove will be towable, external prime mover to move it is not included in Cavotec scope.

When not in use the PowerMove can be disconnected by the PowerFeed and parked to a storage warehouse.

The PowerMove shall be sized to handle the shore power cables to supply to the ship 20 MVA at 11 kV. Together with the power cables, another insulated cable (neutral cable) shall be handled by the PowerMove to permit the connection of the shore transformer centre star on board of the ship.

Control signals between the shore and the PowerMove/Ship shall be transferred by a separate cable reel installed on the PowerMove, while a third cable reel shall be used to power the PowerMove.

Any external protection to temporary cover cables on shore it is not included in Cavotec scope.

The shore connection cables stored on the PowerMove reel shall be enough to permit the PowerMove to drive 20 m from the shore PowerFeed.

Preliminary dimensions and geometry of the PowerMove are in drawing 031017-T02b.

2. Operation description

To connect the ship following main operations shall be carried out

- Drive/Tow the PowerMove from the storage warehouse to the PowerFeed (chose the side according to the position of the ship shore connection hatch)
- Open the shore PowerFeed covers if any
- Connect the PowerMove auxiliary and control cables to the corresponding socket outlets
- Connect the HV Reel Shore Connection Cable plugs to the HV PowerFeed
- Anchor the shore connection cables in the appropriate anchoring point with the cable grips supplied (note that anchoring point shall be aligned with path of the HV cables on quay –no turns are allowed)
- Switch on the PowerMove
- Lift trench covers (if any)
- Drive/Tow the PowerMove in the connection position (in front of the ship shore connection hatch)
- Manoeuvre the jib crane to pass the cables on board of the ship



- Connect the cables plug to the ship "shore connection panel" socket

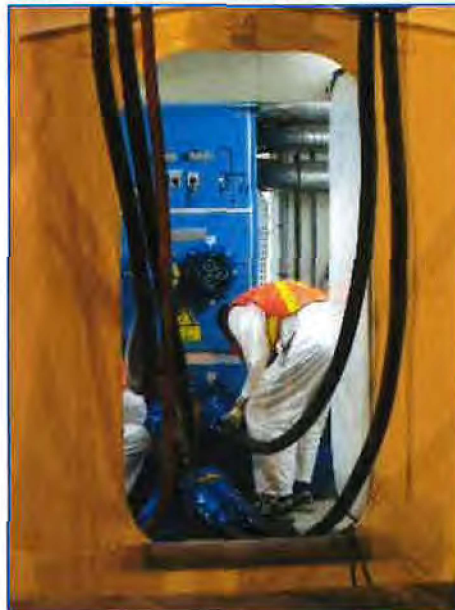

- **Reposition crane to allow a slack of cable to compensate different tide level during the connection and the side shift of the vessel**



- *If required reposition crane and/or the trailer according vessel movements during the connection*
- **Start the Medium Voltage electrical shore connection procedure**

To disconnect the ship from the shore following the above mentioned procedure in reverse sequence.

3. Scope of supply

Following are described the main parts of the shore-based PowerMove (see also figure, for information only).

All the exposed part of the PowerMove shall be coated for marine environment.

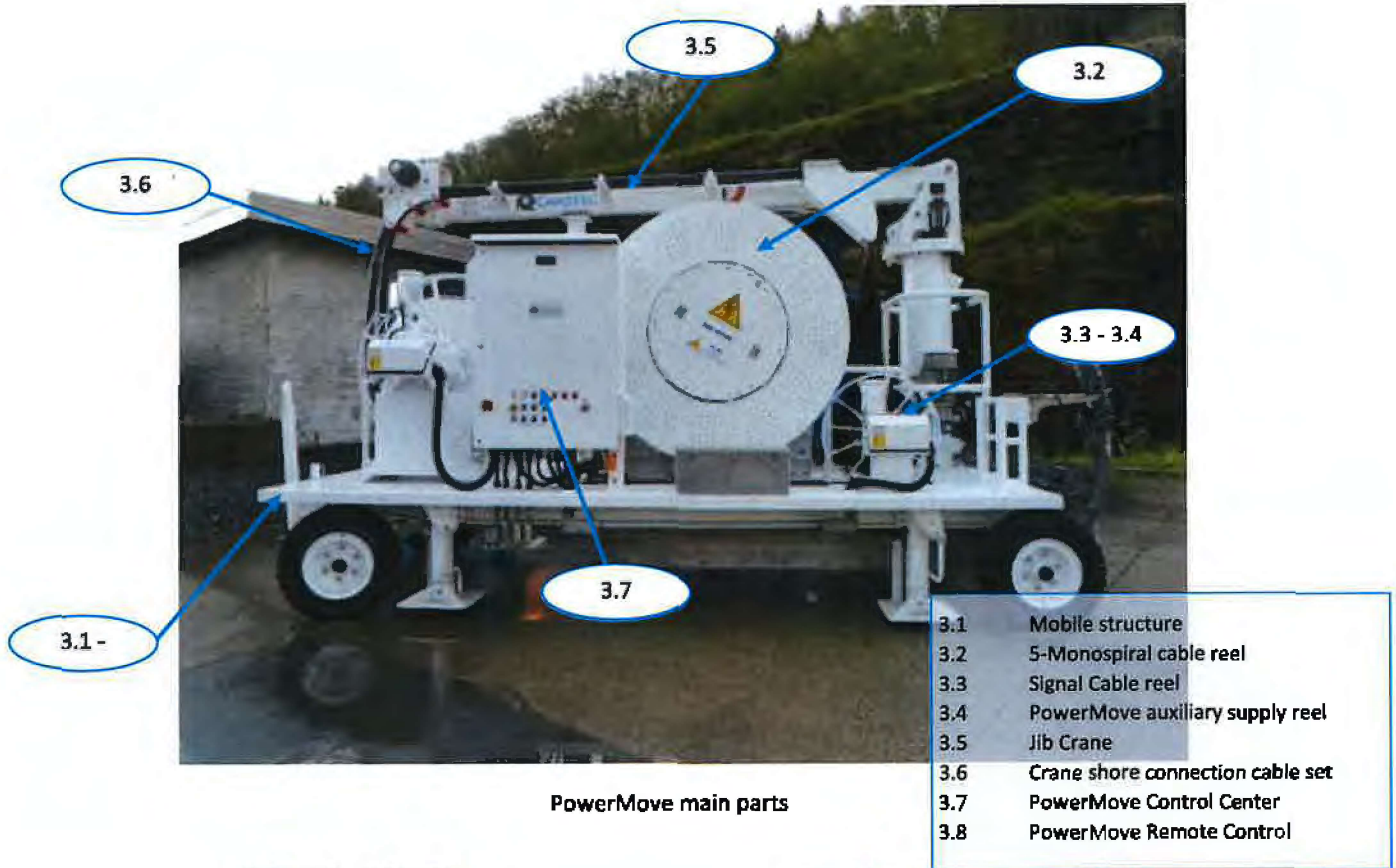

PowerMove main parts

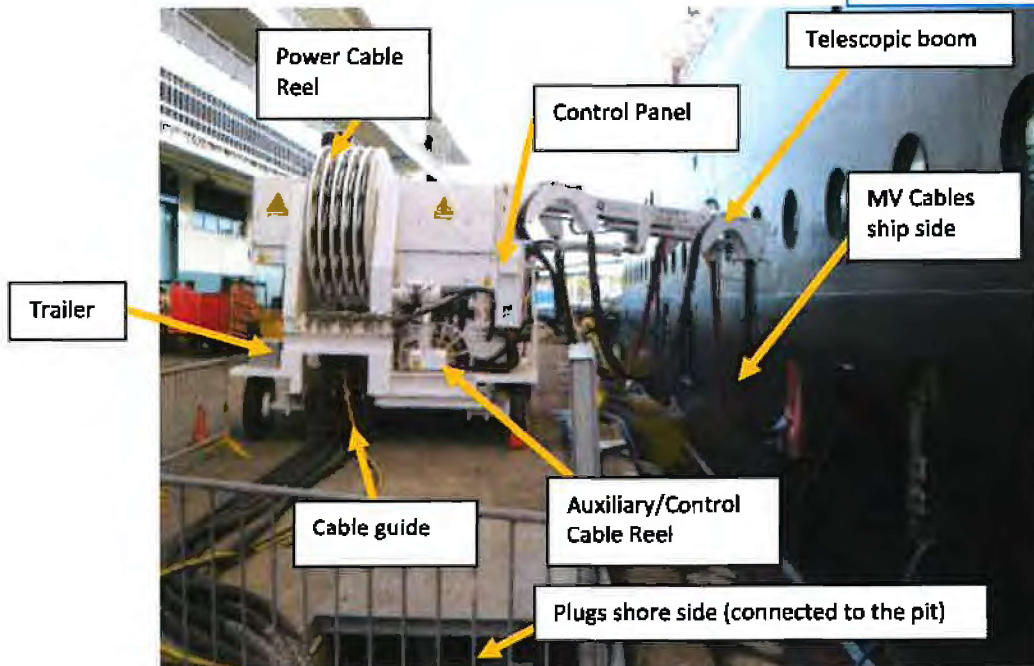

3.1 Mobile structure

The mobile structure shall be the wheeled structure on which are installed all the other components of the PowerMove.

The structure shall be mounted on 2 front and 2 rear wheels with rubber tires. Structure shall be manufactured in mild steel and painted for marine environment.

3.2 5-Monospiral cable reel

The 5-Monospiral reel shall reel in and out the shore connection cables, needed to connect the PowerMove to the socket outlet PowerFeed Box, during the translation of the PowerMove along the berth.

Shore connection cables shall consist in:

4 power cables

1 neutral cable

Neutral cable shall be the same type of the power cables in order to equilibrate drum.

The 5-Monospiral reel shall consist in following main parts:

3.2.1 Drive Unit

The 5-monospiral reel shall be controlled by a vector drive with closed loop speed reference (New Cavotec Control – NCC) in order to achieve precise speed and torque control on a standard squirrel cage motor. A chain transmission shall be used between drive unit and drum.

3.2.2 5-Monospiral drum

The internal diameter of the drum shall be selected to meet the minimum bending radius requirement of the shore connection cable and to ensure an optimal relationship between reeling torque and cable tension. The external diameter of the drum shall be selected to ensure that the full cable lengths can be accommodated. The drum shall have five different compartment for the cables in order to keep the five vertical layer of cable separated. Compartments width of the drum shall be sized according to the cable outer diameter, avoiding too high friction between cable and drum when rotating.

Drum shall have at least 12 spokes with ext. section 70x40 mm

Drum shall be manufactured in mild steel, hot dip galvanized and painted for marine environment.

3.2.3 Collector

The collectors shall be mounted on the sides of the drum and shall be divided in High and Low Voltage section.



The High voltage (HV) collector shall consist of 12 power fixed brass sliprings against which a number of rotating carbon brushes are mounted. Corresponding phases of the four power cables shall be connected to separate parallel insulated sliprings (the four sliprings of the same phase are insulated from each other) in order to avoid a parallel connection of the power cables.

HV insulators and air separate the parallel phase sliprings of each phase. Maximum Voltage rating of the HV section shall be 12 kV.

The low voltage (LV) collector section shall consist of + 1 earth (PE) +1 Neutral + 20 pilots sliprings against which a number of rotating carbon brush tips rub. Fibreglass insulators and air separate each phase. The LV sliprings are used for the pilot circuits of the plugs.

The slipring will include capacity isolators with a switch to turn on a strobe on the machine while the system is under HV (High Voltage).

3.2.4 Motor

Motor shall be a totally enclosed squirrel cage, fan cooled with heater and brake.

3.2.5 Power and Neutral cables

The cables on 5-Monospiral cable reel shall be following:

Cable shall be following type:

250 KCMIL 15KV 3/C +2x GNDS+GC MMV

The ground check wires shall be used shore side according IEC requirements. Cable shall be high flexible type suitable for cable reel application.

3.2.6 Plug Shore side

Power plugs shall be 4 pc. Cavotec PC6 with following characteristics:

- Male connectors
- Voltage rating: 12.000 V
- Amperage rating: 500 Amp
- 7 pilots pins– only one used for the ground check wire.
- The plug shall include a Kirk key pin to release key on Kirk block on related socket.

Neutral plug shall be 1 pc. Cavotec PCS with following characteristics:

- Male connector
- Voltage rating: 7.200 V

The plugs shall match the ones actually installed in LA berth.



3.3 Signal Cable reel

The Signal cable reel shall reel in and out the signal cable, needed to transfer safety controls between the shore and the ship/PowerMove. At least 48 signal shall be available; the cable shall be terminated with 48 cores plug. The cable shall be split on the trailer in two different cables to connect signal to the ship as required IEC 80005:1 Cruise annex.

3.4 PowerMove auxiliary supply reel

The AMP auxiliary supply cable reel shall reel in and out the auxiliary power cable, needed to connect the PowerMove to the socket outlet PowerFeed, during the translation of the PowerMove along the berth. The PowerMove auxiliary supply cable shall be able to provide at 480 V 50 Hz 3 phases enough power to feed all the equipment on board of the PowerMove.

3.5 Jib Crane

The Jib crane shall provide an easy handling of the shore connection cables from the PowerMove to the ship shore connection hatch. Rotation of the crane as the movement of the beam (inclination and outreach) shall be hydraulic.

A Cable support shall be fixed to the crane end of the moveable beam to avoid exceeding the bending radii of the cables and furthermore it shall permit to anchor properly the cables using cable grips.

3.6 Crane shore connection cable set

As mentioned above these cables shall connect the PowerMove to the ship and shall be handled from the PowerMove to the ship using the jib crane.

The cable set consist in following cables:

- A. 4 power cables 250 KCMIL 15KV 3/C +2x GNDS+GC MMV

Power cables shall be connected on one end to the phase brushes in the 5-Monospiral reel collector, avoiding any parallel connection of the phase cores of the different cables. The earth cores shall be connected to the brushes of the earth sliprings. Pilot cores shall be connected to the corresponding pilot sliprings brushes. The other end the power cables shall be wired to power Cruise plugs as defined in IEC 80005:1 in order to match the sockets on board of the cruise ships.

- B. 1 neutral cable with following technical characteristics:

Voltage rating: 3,6 kV or higher
 Amperage rating 250 A
 Section 95 sqmm or higher
 Single core cable
 Flexible type

The cable shall be wire on one end to the neutral slipring brushes in the 5-Monospiral reel collector, while at the other end shall be connected to neutral Cruise plug as defined in IEC 80005:1 in order to match the neutral socket on board of the cruise ships.

- C. 2 control cables

Technical characteristic of the cables shall be defined according to the communication and emergency signal that will be exchanged between shore and ship and the communication protocol used on board of the ship (24 signal at 110 VDC and 24 at 24 VDC).

One end on the cables shall be wired to the signal reel collector and the other end to a communication plug (EPIC series H24) to match the socket on board of the cruise ship.



Control socket on vessel

3.7 PowerMove Control Center

The PowerMove control center shall control and coordinate all the operation of the system:

- 5- Monospiral cable reel
- AMP power cable reel
- Jib crane
- Feedback
- Ground check relay



From the control center shall be also available feedbacks signal, as required by IEC 80005:1, for the ship and/or the shore.

Acoustic and optical signals shall be used to indicate trolley operation while is moving; a dedicated strobe shall be installed to show the surrounding operators that the system is under voltage.

Two E-stop each side shall be installed for machine emergency stop and HV E-stop (signal to shore CB via the control reel).

Floodlight shall be installed to illuminate connection place during dark.

3.8 PowerMove Remote Control

The remote control shall be the interface to operate all the PowerMove functions (fixed controls on the control panel shall be available for emergency maneuvers). When switched on the PowerMove control center, operating the selector on the panel, all PowerMove operations shall be execute through the remote control.

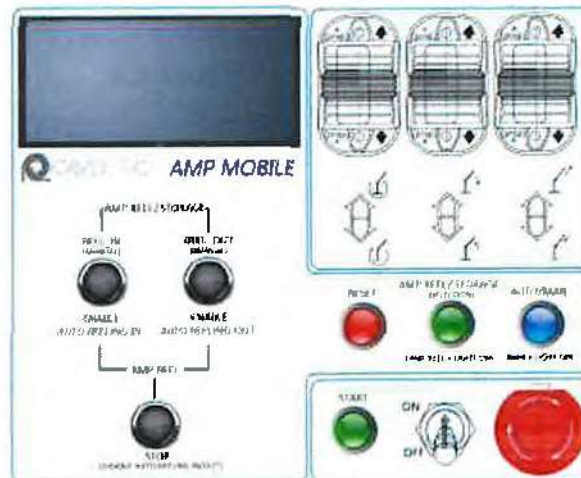

Radio remote control (example)

3.9 Recommended spare parts

Following spare parts shall be included with the proposal

Note oil/grease and other consumables are not included in the quotation and should be outsourced locally.

Preliminary Spare parts list (to be verified during detailed engineer):

Description 031017-T01-SPR1b	Qty
Crane kit (refer to detailed list) - not including consumables	1
Trailer spare kit (refer to detailed list)	1
HV connector ship side (one single connector)	1
HV plug shore side(one single plug)	1
Drum gasket	3
Drum cover gasket	3
Rotary limit switch 1:48/4 IP66 B3	1
Cavotec Motor translation shore side HV reel	1
Brushgear KP 20/450	4
Brushgear KP 2 270	2
Cavotec Motor translation shore side Aux/control reel	1
Cable Guide Roller L=400	2
Cable roller kit for AMP L=660	4
PLC + I/O cards	1
Slipring dia.450 6 holes M12	2
Insulator IGN 10/700	3
Relay 2NO+2NC, 24VDC coil electronic, 10A	4
Relay 1CO, 24VDC coil, 6A, 250V contacts	8
Fuses set	1
Power supply 1Ø 240W 85-264VAC/24VDC	1
Siren LP 9-28VDC IP65, 32 sounds, red	1
Frequency converter closed loop - shore side HV reel	1
Radio remote transmitter	1
Junction box heating element	2
Encoder Heidenhain ERN430 Cavotec version HTL	1

Crane spare parts	Qty
Flexible hose kit	1
Sliding blocks Kit	1
Pressure filter cartridge	1
Return filter cartridge	1
Pressure transducer	1
Conn. cable with connector for transducer	1
Minor electrical spares (fuses, relay) kit	1
Rotation switch	1
Hydraulic pump for powerpack	1
Elastic joint on HPU	1
Electric motor for hydraulic pack (UL)	1
Thermostat on HPU (UL)	1

Proportional distributor	1
Complete Gearbox unit for rotation	1
Seal Kit for Lifting cylinder	1
Seal Kit for Telescope cylinder E1	1
Seal Kit for Telescope cylinder E2	1

Trailer spare parts	Qty
Wheels	1
Ball bearings	4
Neutral axes	1

4. Datasheet

System type	PowerMove	
Proposal identifying code	031017-T02c	
Machine type	PowerMove 11kV40 – C – C08TU0	
Weight	About 12 ton	
Drawing	031017-T02b	
Ambient condition	Ambient temperature	-10°C - +40°C
	Environment	close to the sea with salt and high humidity
Main system data	Transfer power	20 MVA @ 11 kV
	Maximum Voltage	12 kV
	Traction	Towable
	Translation	40 m
	Crane	marine crane with hydraulic actuation
	Crane main data	telescopic crane with 13 m maximum extension
	Auxiliary supply	480 V, 40 A
	Speed while cable connected (unreeling speed)	20 m/min (max)
Shore side HV reel	System type	5 – Monospiral drive by frequency converter with closed loop
	Cable quantity	42 m active length + two dead turns
	Slipring	- 12 rings rated 12 kV max - 4 each phase isolated to allow individual cable protection on shore switchboard - 1 ring for neutral - 1 ring for ground - 4 rings for ground check
	Cables	250 KCMIL 15KV 3/C+2x GNDS+GC MMV
	Connectors	- 4 x PC6 12 kV – for power cables - 1 x PC5 7,2 kV for neutral
Auxiliary supply reel	System type	Reel - 63 A
	Cable quantity	40 m active length
	Connectors	1 aux plug ESL

Control reel	System type	Reel – 48 cores 2,5 sqmm
	Cable quantity	40 m active length
	Connectors	1 control plug 48 pin
Trailer	Propelling	Towable
	Tires type	Rubber
Crane	Type	Marine crane hydraulic
	Model	M40 E2 (preliminary)
Ship side cables/connectors	Cables	- 4 cables - 250 KCMIL 15KV 3/C +2x GNDS+GC MMV - 1 neutral cable 95 sqmm 3,6 kV - 2 control cables 24 cores each (24 VDC and 110 VDC)
	Connectors	- 4 x 12 kV – for power cables according IEC 80005:1 annex C - 1 x 7,2 kV - for neutral cable according IEC 80005:1 annex C - 2 x communication plugs according IEC 80005:1 annex C
Control panel	Material	AISI 304 painted
	Voltage	480 V, 40 A
	UPS	not included
Radio control	Brand	Cavotec
	Type	Specific design ergonomically for the application

ATTACHMENT B

IRAN CONTRACTING ACT OF 2010 COMPLIANCE AFFIDAVIT

(California Public Contract Code Sections 2200-2208)

The California Legislature adopted the Iran Contracting Act of 2010 to respond to policies of Iran in a uniform fashion (PCC § 2201(q)). The Iran Contracting Act prohibits bidders engaged in investment activities in Iran from bidding on, submitting proposals for, or entering into or renewing contracts with public entities for goods and services of one million dollars (\$1,000,000) or more (PCC § 2203(a)). A bidder who "engages in investment activities in Iran" is defined as either:

1. A bidder providing goods or services of twenty million dollars (\$20,000,000) or more in the energy sector of Iran, including provision of oil or liquefied natural gas tankers, or products used to construct or maintain pipelines used to transport oil or liquefied natural gas, for the energy sector of Iran; **or**
2. A bidder that is a financial institution (as that term is defined in 50 U.S.C. § 1701) that extends twenty million dollars (\$20,000,000) or more in credit to another person, for 45 days or more, if that person will use the credit to provide goods or services in the energy sector in Iran and is identified on a list created by the California Department of General Services (DGS) pursuant to PCC § 2203(b) as a person engaging in the investment activities in Iran.

The bidder shall certify that at the time of submitting a bid for new contract or renewal of an existing contract, the bidder is **not** identified on the DGS list of ineligible businesses or persons and that the bidder is **not** engaged in investment activities in Iran in violation of the Iran Contracting Act of 2010.

California law establishes penalties for providing false certifications, including civil penalties equal to the greater of \$250,000 or twice the amount of the contract for which the false certification was made; contract termination; and three-year ineligibility to bid on contracts (PCC § 2205).

To comply with the Iran Contracting Act of 2010, the bidder shall provide its vendor or financial institution name, and City Business Tax Registration Certificate (BRTC) if available, in completing ONE of the options shown below.

OPTION #1: CERTIFICATION

I, the official named below, certify that I am duly authorized to execute this certification on behalf of the bidder or financial institution identified below, and that the bidder or financial institution identified below is **not** on the current DGS list of persons engaged in investment activities in Iran and is **not** a financial institution extending twenty million dollars (\$20,000,000) or more in credit to another person or vendor, for 45 days or more, if that other person or vendor will use the credit to provide goods or services in the energy sector in Iran and is identified on the current DSG list of persons engaged in investment activities in Iran.

Vendor Name/Financial Institution (printed) Cavotec USA Inc.		City of LA Business Tax ID # (or n/a) N/A 0003156855
By (Authorized Signature) 		
Print Name and Title of Person Signing Alfredo Rivas (POA), Regional Sales Director Americas		
Date Signed	CITY EMPLOYEE USE ONLY: (Signature)	(Print Name) jlo

OPTION #2: EXEMPTION

Pursuant to PCC § 2203(c) and (d), a public entity may permit a bidder or financial institution engaged in investment activities in Iran, on a case-by-case basis, to be eligible for, or to bid on, submit a proposal for, or enter into, or renew, a contract for goods and services. If the bidder or financial institution identified below has obtained an exemption from the certification requirement under the Iran Contracting Act of 2010, the bidder or financial institution shall complete and sign below and attach documentation demonstrating the exemption approval.

Vendor Name/Financial Institution (printed)		City of LA Business Tax ID # (or n/a)
By (Authorized Signature)		
Print Name and Title of Person Signing		
Date Signed	CITY EMPLOYEE USE ONLY: (Signature)	(Print Name)

1 2 3 4 5 6 7 8 9 10 11 12

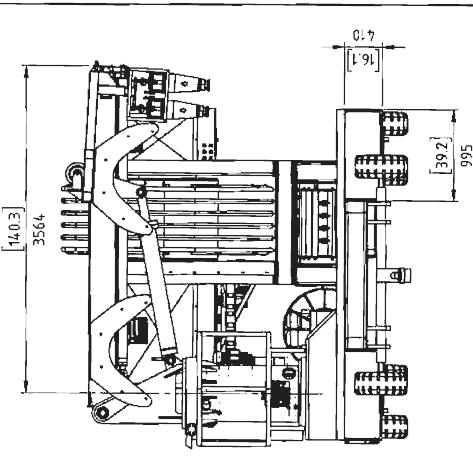

HV cable on HV reel/Crane Z50 KC/MIL 15KV 37C + 2x GNDS+6C MMVY

Max diameter 65 mm
Max weight 8 Kg/m

Quantity of cable for power cable 40 m (480V)

Quantity of cable for control cable 40 m

Quantity of cable of HV cable reel 42 m

Quantity of cable for the crane:
20 m for the phases
25 m for neutral

FOR OFFER

PowerMove with cables 11600 kg
PowerMove without cables 9000 kg

CAVOTEC
The drawing and the rights are protected by this drawing and the property of CAVOTEC. This drawing is reserved for the use of the client and is not to be reproduced or used for any other purpose without the written permission of CAVOTEC. www.cavotec.com

CAVOTEC Italy - Nova Milanese (MB) Italy
CAVOTEC NUMBER: OP-031017-T02
PART NUMBER: OP-031017-T02
REV: PowerMove layout
EXPLODED: PL
REVISED: B
DATE: 15 May 22
DRAWN BY: SL
CHECKED BY: [Signature]
DATE: 15 May 22
REVISED: [Signature]
DATE: 15 May 22
DRAWN BY: [Signature]
CHECKED BY: [Signature]
DATE: 15 May 22

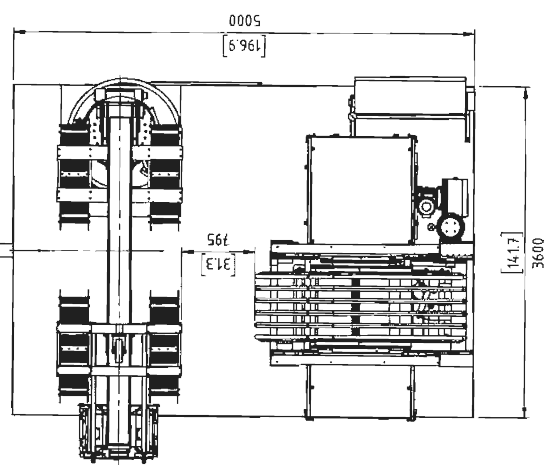
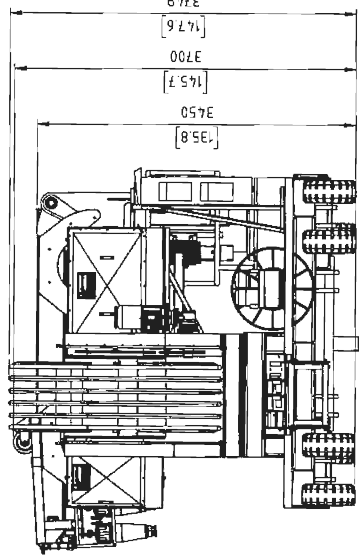
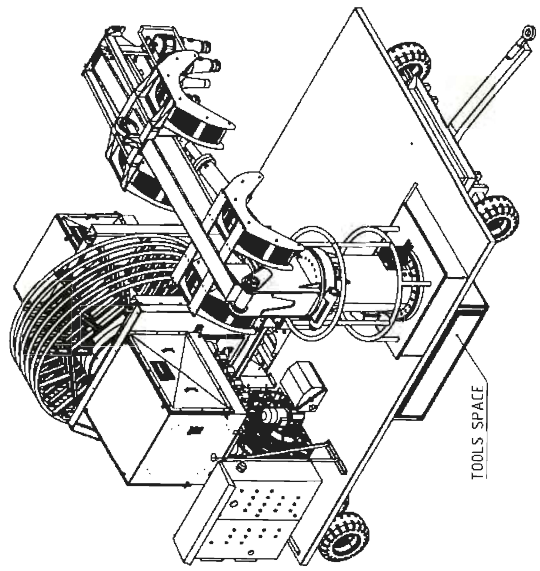
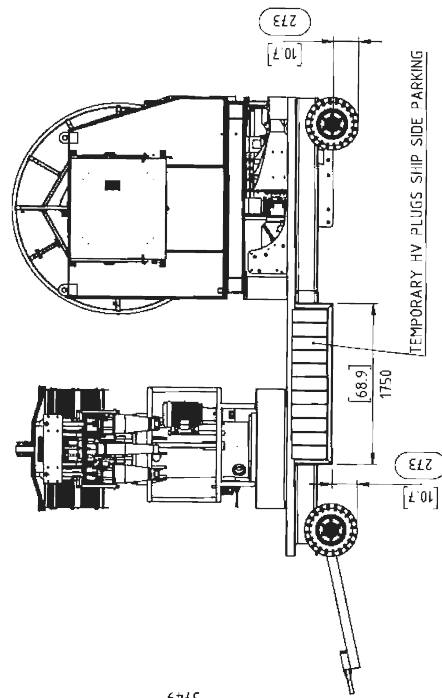

REV	DESCRIPTION	DRAWN BY	DATE	REF. ECC
B	REVISION TABLE QUANTITY SHORE SIDE AND DEALER	SL	15 May 22	

REV	DESCRIPTION	DRAWN BY	DATE	REF. ECC
A3	1:50			

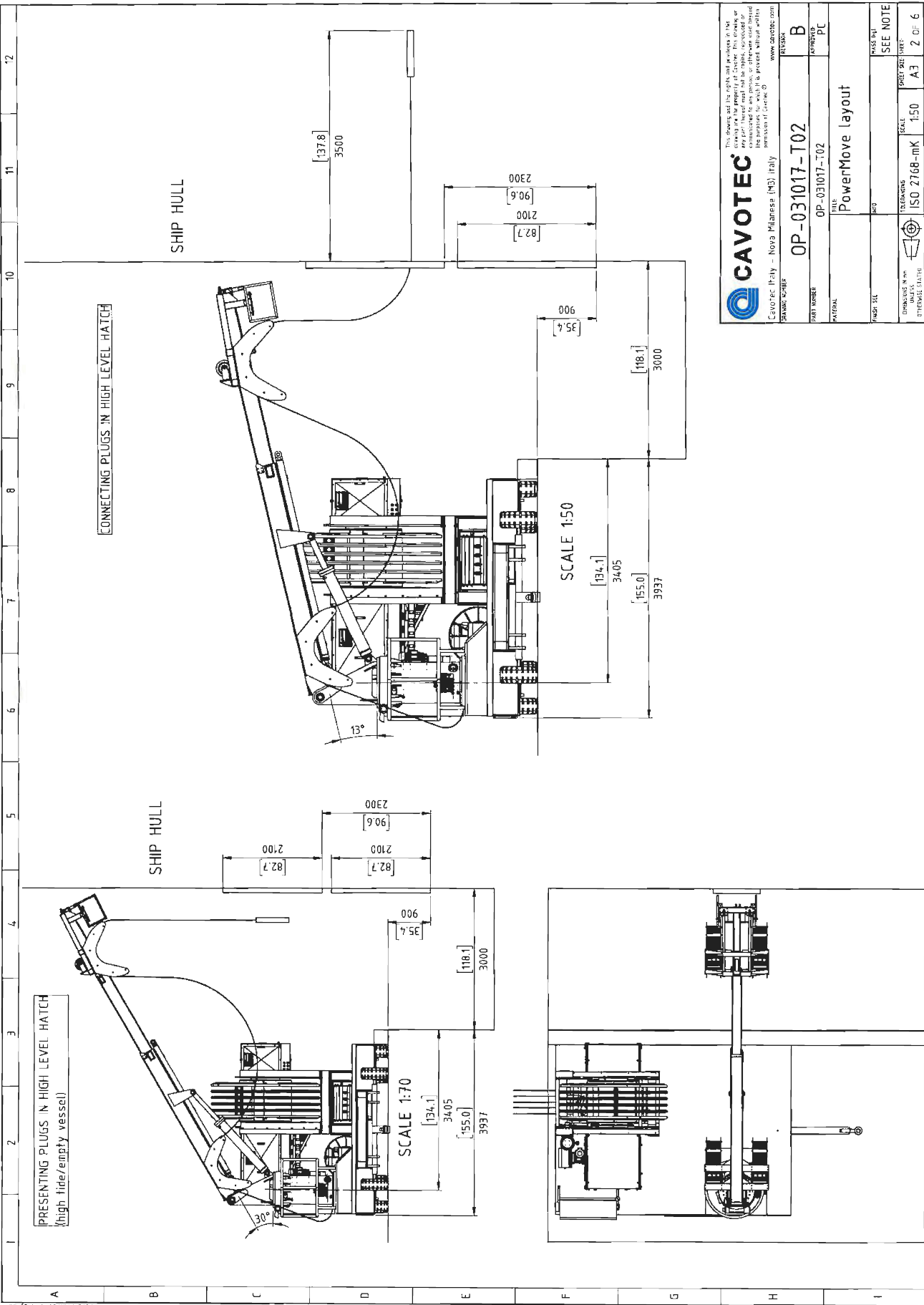

This drawing and the rights and privileges in it are the property of CAVOTEC. This drawing or any part of it is not to be reproduced, stored in a retrieval system, or otherwise used beyond the purposes for which it is issued without written permission of CAVOTEC. www.cavotec.com

DESIGN NUMBER	OP-031017-T02	REVISION	B
PROJECT NUMBER	OP-031017-T02	FORNOSTR.	PC
TITIAL	THIS	PowerMove layout	
NUMBER SET	3/3	MASS INT.	SEE NOTE
DRAWING WITH DIMENSIONS	ISO 2768-mK	SCALE	A3 2 OF 6

12 11 10 9 8 7 6 5 4 3 2 1

CONNECTING PLUGS IN HIGH LEVEL HATCH

SHIP HULL

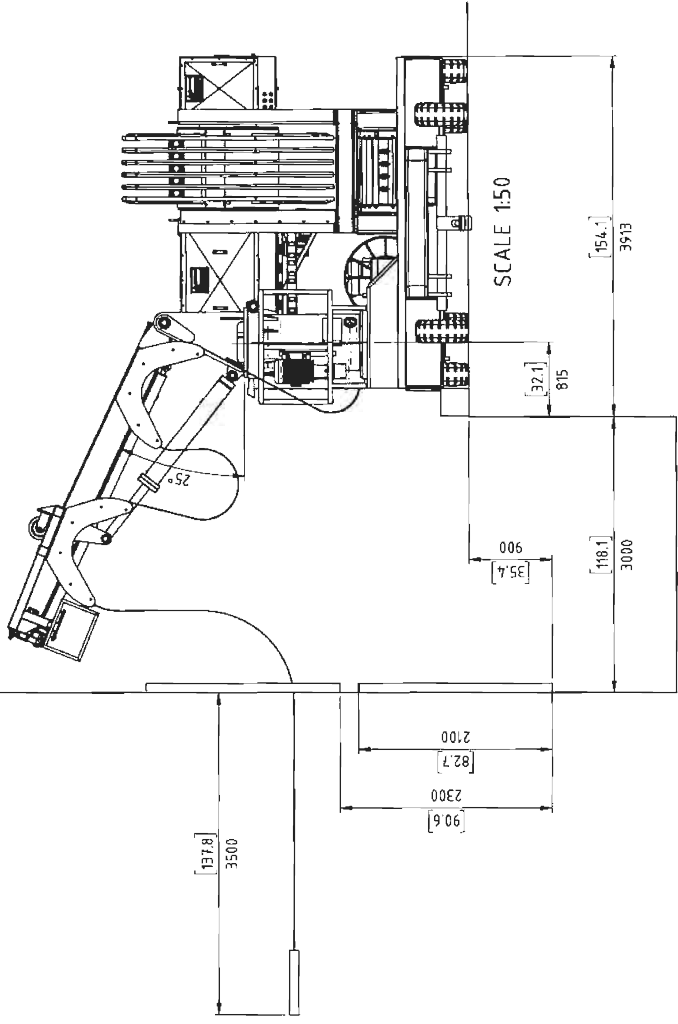

PRESENTING PLUGS IN HIGH LEVEL HATCH
(high tide/empty vessel)

SHIP HULL

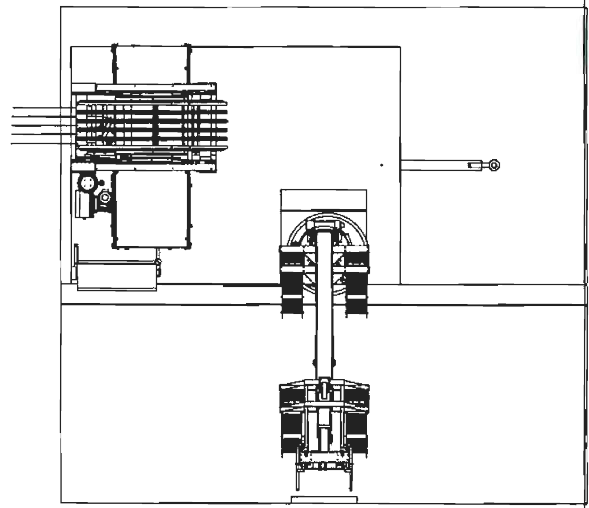
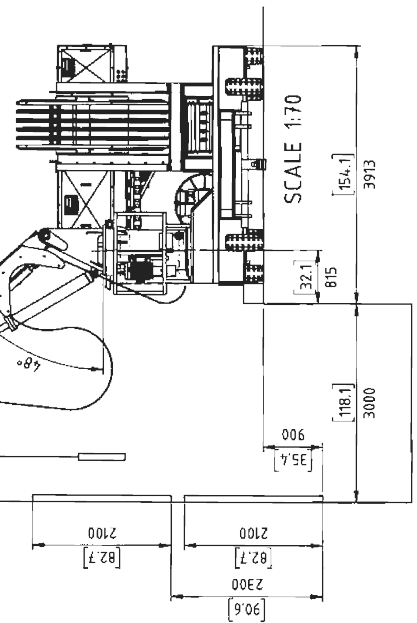

CAVOTEC Italy - Nova Milanese (MB) Italy
www.cavotec.com

PROJ. NUMBER	OP-031017-T02
VERSION	PC
TITLE	PowerMove layout
SCALE	1:50
SHEET NUMBER	5 OF 6

