

Construction and Maintenance

On-Call Underwater Hard Hat Diving Services

REQUEST FOR PROPOSALS



July 19, 2024

RAMP ID # 215908

Transmittal 1

July 19, 2024

Prospective Consultants:

SUBJECT: REQUEST FOR PROPOSALS FOR ON-CALL UNDERWATER HARD HAT DIVING SERVICES

The City of Los Angeles Harbor Department (Harbor Department) invites the submittal of proposals to provide on-call underwater hard hat diving and related services for wharf pile inspections, pile wrapping, vessel hull cleaning, wharf repair, and other miscellaneous services. These services shall commence after a contract is approved by the Board of Harbor Commissioners.

Instructions and forms to be used in preparing the qualifications are found in the information included in the Request for Proposals (RFP).

The schedule for this RFP will be as follows:

Request for Proposals Published	Friday, July 19, 2024
Questions Due	Tuesday, July 23, 2024 by 3pm
Responses Posted	Thursday, July 25, 2024
Proposals Due	Monday, August 5, 2024 by 3pm

If your firm cannot agree to the requirements exactly as set forth in this RFP, please do not submit a proposal.

For questions regarding this RFP, please contact Susana Eldridge by email at Seldridge@portla.org. Questions must be submitted by Tuesday, July 23, 2024 by 3pm. Responses will be posted on the [Harbor Department's website](#) and the Regional Alliance Marketplace for Procurement (RAMP), at www.rampla.org, on Thursday, July 25, 2024. It is the responsibility of all proposers to review both websites for any RFP revisions or answers to questions prior to submitting a proposal in order to ensure their proposal is complete and responsive.

In addition to providing information requested in this RFP, it should be noted that there are administrative documents that must be submitted with the proposal. Please refer to the Business Enterprise Programs and Contract Administrative Requirements section of this RFP. **In order for your proposal to be deemed responsive, these documents MUST be included with your proposal.**

All consultants and subconsultants must be registered on RAMP at the time proposals are due. If selected for award, for-profit companies and corporations must comply with RAMP's demographic reporting requirements, per the Mayor's Executive Directive 35.

Sincerely,

Susana Eldridge for

TRICIA J. CAREY

Director, Contracts and Purchasing Division

TABLE OF CONTENTS

1. INTRODUCTION	6
1.1 Brief Overview of the Project	6
1.2 The Port of Los Angeles	6
1.3 The Construction and Maintenance Division	6
2. PROJECT DESCRIPTION	7
2.1 Project Goals and Objectives	7
2.2 Project Scope of Work	7
3. PROPOSAL REQUIREMENTS	11
3.1 Proposal Questions.....	11
3.2 Proposal Submission	11
3.3 Evaluation Process and Selection Criteria	11
3.4 Proposal Content	12
3.5 Checklist for RFP Submittal Requirements	19
4. STANDARD CONTRACT PROVISIONS	20
4.1 Affirmative Action	20
4.2 Small/Very Small Business Enterprise Program and Local Business Preference Programs.....	20
4.3 Business Tax Registration Certificate.....	20
4.4 Indemnity and Insurance Requirements	21
4.5 Conflict of Interest	25
4.6 Compliance with Applicable Laws	25
4.7 Governing Law / Venue	25
4.8 Termination Provision	26
4.9 Proprietary Information	26
4.10 Trademarks, Copyrights, and Patents	27
4.11 Confidentiality	27
4.12 Notices	27
4.13 Termination Due to Non-Appropriation of Funds.....	27
4.14 Taxpayer Identification Number	28
4.15 Service Contractor Worker Retention Policy and Living Wage Policy Requirements	28
4.16 Wage and Earnings Assignment Orders/Notices of Assignments	28
4.17 Equal Benefits Policy	28
4.18 State Tidelands Grants	29
4.19 Contract Solicitations Charter Section 470 (c) (12)	29
4.20 Iran Contracting Act of 2010	29
4.21 Recordkeeping And Audit Rights.....	30

ATTACHMENTS / EXHIBITS

Attachment 1 – Pile Wrapping

Attachment 2 – Water Depths

Attachment 3 - Contractor's Resume

Attachment 4 – Contractor's Employee Resume

Exhibit A - Affirmative Action Program Provisions

Exhibit B – Small/Very Small Business Enterprise Program

Exhibit C – Proprietary Small Business Enterprise Application

Exhibit D - Business Tax Registration Certificate (BTRC) Number

Exhibit E - Equal Benefits Ordinance

Exhibit F - RFP Selection Evaluation Form

Exhibit G – City Ethics Commission (CEC) Forms 50 and 55

Exhibit H – Iran Contracting Act of 2010

1. INTRODUCTION

1.1 Brief Overview of the Project

The Construction and Maintenance Division is soliciting proposals from qualified contractors to provide on-call underwater hard hat diving and related services for wharf pile inspections, pile wrapping, vessel hull cleaning, wharf repair and other miscellaneous services as described in this RFP. The Port of Los Angeles maintains approximately 23,000 wooden piles of which approximately 20,000 are bearing piles and 3,000 are fender piles.

The duration of the contract(s) awarded as a result of this RFP is expected to be three-years from the date of execution of the contract(s). The Harbor Department may award more than one contract to qualified and responsive proposers as a result of this RFP process and based on Harbor Department project needs. Award of the contract(s) will be subject to Board approval. The Harbor Department reserves the right to award to one or a limited number of contractors, or to make no award.

1.2 The Port of Los Angeles

The Port of Los Angeles is America's Port®, the nation's premier gateway for international commerce and the busiest seaport in the Western Hemisphere. Located in San Pedro Bay, 25 miles south of downtown Los Angeles, the Port encompasses 7,500 acres of land and water along 43 miles of waterfront.

The Port features both passenger and cargo terminals, including cruise, container, automobile, breakbulk, dry and liquid bulk, and warehouse facilities that manage billions of dollars' worth of cargo each year. One of the world's busiest seaports and leading gateway for international trade in North America, the Port of Los Angeles has ranked as the number one container port in the United States each year since 2000. In 2023, the Port handled a total of 8.6 million container units.

The Port of Los Angeles is a department of the City of Los Angeles (also known as the Los Angeles Harbor Department) and is governed by the Los Angeles Board of Harbor Commissioners, a panel appointed by the Mayor of Los Angeles. Although the Port is a City department, it is not supported by City taxes. Operating as a landlord port with more than 200 leaseholders, the Port instead generates its revenues from leasing and shipping service fees. The Port's jurisdiction is limited to the Harbor District, which includes property in San Pedro, Wilmington, and Terminal Island.

1.3 The Construction and Maintenance Division

The Construction and Maintenance Division provides 24-hour, seven-days-a-week support for the maintenance, repair, alteration, and reconstruction of Harbor Department-owned facilities and infrastructure. Staff assigned to this Division possess skills in traditional crafts such as electrical services, plumbing, carpentry, vehicle and equipment maintenance, painting, roofing, custodial services and gardening, as well as in more specialized fields such as the maintenance and repair of marine vessels, pile driving and heavy equipment operation. Selected services are also provided to Port customers on a reimbursable basis, as time and scheduling permit.

2. PROJECT DESCRIPTION

2.1 Project Goals and Objectives

The Harbor Department is seeking qualified contractors to provide on-call underwater hard hat diving and related services. These services are required in order to support on-going operations involving primarily maintenance but also construction activities at the Port of Los Angeles. Specific support activities include pile inspection, pile wrapping, vessel hull cleaning, wharf repair and other miscellaneous underwater inspection and construction work.

2.2 Project Scope of Work

The scope of this project includes wharf inspection and repair (approximately 200-300 piles are wrapped annually per specifications in Attachment 1), damage surveys, slope/seawall inspection and repair, and underwater vessel maintenance and inspection. All wrapping materials will be provided by the Harbor Department.

1. The following requirements encompass the scope of work to be provided by the contractor(s):

Two (2) primary hard hat dive teams, fully equipped, each consisting of one (1) skilled hard hat diver, one (1) tender and one (1) standby diver, one of which will serve as the designated person in charge, available Monday through Friday on an eight (8) hour shift. Please note that the dive team will be expected to provide services on an emergency call-out basis, as required. Equipment shall include, but not be limited to, a dive boat, a work punt or float, and hand equipment enumerated in Section 3.4, subsection 6 (entitled "Cost") of this RFP.

Estimated annual usage is as follows:

Primary Team(s) –	Diving Days	220 days (each team)
	Overtime	20 hours (each team)
	Saturday/Sunday	8 days (each team)
	Holidays	2 days (each team)

NOTE: With regard to estimated annual usage, this is the basis for the evaluation of the proposals and represents an estimate as to the frequency that services will be required. The Harbor Department does not guarantee that these figures will be met or that they may not be exceeded and makes no guarantee as to the accuracy or reliability of these figures. Availability of the figures shall in no way relieve a Proposer from the responsibility of determining for itself the business potential of the opportunities outlined in this RFP.

2. The following are possible additional services which may be requested:
 - A. One (1) as-needed hard hat dive team, fully equipped, consisting of one (1) skilled hard hat diver, one (1) tender and one (1) standby diver, one of which will serve as the designated person in charge, available upon forty-eight (48) hours written or oral notice. The estimated annual usage of the as-needed team is 30 diving days. Equipment shall include, but not be limited to, a dive boat, a work punt or float, and hand equipment enumerated in Section 3.4, subsection 6 (entitled "Cost") of this RFP.
 - B. As-needed SCUBA or surface-supplied diver(s) to perform hull cleaning on Harbor Department vessels. Equipment, certification, and staffing should meet industry standards and all applicable state laws and regulations. The estimated annual usage of the as-needed diver(s) is 10 to 15 vessels ranging from 25 feet to 65 feet in length. This service would not require hard hat diving and may be subcontracted based on company needs.
 - C. As-needed recovery of sunken wharf components or vessels.
 - D. As-needed pile driving of concrete/steel or timber pile.
3. Contractor(s) shall also provide:
 - A. Underwater services capable of being performed at depths up to seventy- five feet (mean low water – Attachment 2) consisting of:
 - A1. Heavy timber, concrete, and steel wharf and structural construction and reconstruction;
 - B. Annual inspection and evaluation of the condition of timber fender and bearing piles, concrete bearing piles and dolphin piles, metal sheet piles, wharf structure, wharf slope rat-proofing, and electrolysis protection systems;
 - C. Timber wharf maintenance repairs including the installation and replacement of timber jacketing materials (such as plastic wrap) on piles, braces, and structural supports; and stub-pile, barrel, or jacket-pour repairs to bearing piles;
 - D. Maintenance repairs in conjunction with Harbor Department surface crew including concrete pouring; installation of bolts, braces, and stub piles; and buoy line replacement;
 - E. Wharf damage inspections/surveys including preparation of written reports documenting all observed conditions;
 - F. Inspection of new construction for conformance to Harbor Department specifications;
 - G. Inspection of plastic pile wrapping and seals to ensure proper installation by others and to ensure the integrity fully meets Harbor Department requirements;

- H. Application of underwater coatings, paints, and epoxies;
 - I. Underwater hull cleaning of Harbor Department vessels; and
 - J. Provide labor to fabricate ready-to-use pile wrap, and deliver to sites within the Harbor Department.
- 4. Report all information obtained in conducting diving services in a form and manner requested by the Director of Construction and Maintenance. Digital camera pictures will be required to document conditions found on inspections and video recordings will be required to document all underwater work performed.
 - 5. Perform other construction and diving services as requested by the Director of Construction and Maintenance.

NOTE: For purposes of this RFP, proposers should assume that a diving day consists of eight (8) hours of underwater hard hat diving or related activity during a working day, or during shift hours when multiple shifts are worked, Monday through Friday. Diving teams should be available on an on- call basis to respond to emergency situations if required. The Director of Construction and Maintenance or an authorized representative must authorize any additional time to extend the work beyond a diver day, including work performed on Saturdays, Sundays or holidays. The Harbor Department will compensate such additional time at the applicable rate agreed upon. This calculation specifically excludes any loss of time due to unavailability of equipment or any other performance failure of contractor. Personnel who report for work in an unfit condition or who are not otherwise qualified to do the work will render the team unsuitable for work.

- 6. The following equipment must be furnished by the selected contractor:
 - A. Work boats in reliable, seaworthy condition which comply with all applicable state, federal and Coast Guard regulations for licensing and safety, and are not greater than FORTY (40) feet in length and are fully capable of performing all job responsibilities of this contract.
 - B. Hard hat diving suit and accessories (heavy gear-surface supplied commercial diving equipment) to safely perform underwater work at depths up to seventy-five (75) feet (mean Low Low Water).
 - C. Working punt or float not less than TEN (10) feet in length.
 - D. A saltwater pump to effectively clear mud and debris from around pilings for installation of plastic wraps. Pump shall be a minimum of twelve horsepower and have 150 feet of discharge hose with a nozzle assembly.
 - E. Air winch mounted to the dive boat with a minimum of 2,000 lb. pull rating.

F. The following specialized underwater diving services and/or equipment are as needed. The extent to which additional equipment will be needed is not known.

1. Hydraulic saw and power source
2. Hydraulic drill and power source
3. Air lift – 8” diameter PVC pipe with 150 linear feet of air supply hose
4. 5,000 lb. lift bags
5. 8” educator with 20” discharge hose (pump by Harbor Department)
6. Hydraulic jack hammer and power source
7. Underwater color digital camera with flash capability
8. Complete digital recording system, with underwater camera, audio, and deck monitor
9. High pressure water blaster equipment (rated at 10,000 PSI) with pump, hoses and power source for hydraulic displacement of marine growth
10. 300 amp welding unit with oxygen and leads
11. Portable generator, rated output 110 volts

3. PROPOSAL REQUIREMENTS

3.1 Proposal Questions

All questions regarding this RFP must be submitted, in writing, exclusively to Susana Eldridge, the Contract Administrator, at Seldridge@portla.org by no later than 3 p.m. on Tuesday, July 23, 2024.

Attempts to contact any other Harbor Department employee or members of the Board of Harbor Commissioners, either directly or through third-parties acting for or on the proposer's behalf, may be presumed to constitute efforts to bias or influence the competitive process with information not detailed in the RFP and not available on an equal basis to all proposers. Accordingly, such attempts shall constitute grounds to disqualify the proposer undertaking them. Any information provided by the Contract Administrator to one proposer in response to questions shall be provided to all proposers.

3.2 Proposal Submission

One (1) digital copy of your proposal, as one complete file in .pdf format, must be submitted on or before 3:00 p.m. PST on Monday, August 5, 2024 to: Susana Eldridge at Seldridge@portla.org.

Proposers solely are responsible for the timeliness of their submittals. As such, proposers are cautioned to budget adequate time to ensure that their proposals are delivered before the deadline set forth above.

By submitting a proposal, proposers certify that such proposal constitutes their full and complete written response to the RFP and evidences their acknowledgement that additional written material outside of such proposal shall not be considered by the City in connection with this RFP, unless the City provides a written request that they submit additional written materials. Absent such written request, proposers are instructed to not submit to the City written or other materials outside of the proposal, either in a subsequent interview or otherwise.

3.3 Evaluation Process and Selection Criteria

All proposals meeting the requirements of this RFP shall be reviewed and rated by an evaluation committee according to the following criteria: 1) firm qualifications, experience, and references; 2) organization, personnel, and staffing; 3) project approach, work plan, management, safety program, and equipment; 4) rates, fees, and budget control; and 5) clarity and comprehensiveness of the proposal. See Exhibit F.

As part of the evaluation, selected proposers may be asked to perform a sample pile wrap and film their work, at the sole expense of the proposer. The evaluation committee will make the final recommendation for selecting the contractor(s). All recommendations are subject to the approval of the Director of Construction and Maintenance, the Executive Director, and the Board of Harbor Commissioners.

Proposers are advised that all documentation submitted in response to this RFP will be considered property of the Harbor Department and may become available to the public as a public record and be released without further notification. Any information that the proposer considers confidential should not be submitted with the proposal.

The right to reject any and all proposals shall, in every case, be reserved, as shall the right to waive any informality in the proposal when to do so would be to the advantage of the City.

3.4 Proposal Content

The following items shall be included in your proposal:

1. Cover Transmittal Letter

Provide a narrative which introduces the firm and team highlighting the special strengths of the firm to perform the work requested in this RFP. The letter should be signed by an authorized principal of the proposing consulting firm.

2. Firm Qualifications, Experience and References

Provide a narrative describing the firm's qualifications to perform the project work, including past (relevant) experience and at least three client references, with contact names and information. Include information regarding your firm's experience involving the size and level of complexity of the proposed project. Qualifications and experience for proposed subconsultants should also be included.

Identify any members of your proposed team, including proposer's firm and any subconsultant firms, who are former Commissioners, officers or employees of the Harbor Department. Provide their name, proposed team position, and their past position and years of employment/appointment with the Department. If your proposed team does not have any such members, please include a statement in your proposal so stating.

Proposers are advised that it is a proposer's obligation to determine whether any conflicts of interest exist for their team members and the extent to which those conflicts need to be resolved or disclosed prior to engaging in business with the Department.

Provide proof that your firm and staff meet the following requirements:

- A. Company must have a State of California Class "A" contractor's license, issued in the name of the company.
- B. Four (4) years demonstrated company experience performing the following work:
 - 1. Underwater timber wharf repairs including the installation and replacement of timber jacketing materials (such as plastic wrap) on piles, braces, and structural supports;

2. Heavy underwater timber pile maintenance including stub piles, barrel pours, and reinstallation of braces, beam and structural timbers;
 3. Underwater inspection and evaluation of the condition of timber fender and bearing piles, metal piles, wharf slope ratproofing, and electrolysis protection systems;
 4. Underwater concrete wharf inspections and repairs; and
 5. Underwater steel structural inspections and repairs.
- C. Each diver assigned to primary and as-needed hard hat dive teams must have at least 400 dive days, of recent paid experience accumulated within the last four (4) years, in underwater work described above in Item 2, including a minimum of:
1. Forty working days of underwater timber wharf repair work including the installation and replacement of timber jacketing materials (such as plastic wrap) on piles, braces, and structural supports;
 2. Twenty working days of heavy underwater timber pile maintenance work including stub piles, barrel pours, and reinstallation of braces, beam and structural timbers;
 3. Ten working days of underwater concrete wharf inspection or repair work; and
 4. Three working days of underwater steel structural inspection or repair work.
3. Organization, Personnel and Staffing

Provide a brief description of all key personnel and technical staff (including vendors, partners or subconsultants) to be involved and their relationship to the services to be provided.

- Include names, titles, licenses, certificates, fields of expertise, and relevant experience for all proposed personnel and staff. Specifically, include:
 - Class "A" State of California license
 - ACDI (Association of Diving Contractors International) card, certification of completion from an accredited commercial school, or certification of completion from a U.S. military dive school.
 - Any type of certification pertaining to pile wrapping or possession of a Level IV Bridge Inspector certificate from, or in affiliation with, the National Institute of Certifications in Engineering Technologies.
- Identify the Project Manager for the proposed services.
- Complete resumes of any personnel involved with these services should be provided as part of an appendix to the proposal.
- Please complete Attachment 3 – Contractor’s Resume.

- Please complete Attachment 4 – Contractor’s Employee Resume. For Attachment 4, please address experience/hours listed in Section 2.C. above and any other hours and/or skills that specific personnel working on the dive teams may possess. To supplement the information requested in Attachment 4, it is recommended that experience/hours listed in Section 2.C. above and any other hours and/or skills that specific personnel working on the dive teams may possess be presented in a clear 1-2 page summary of proposed dive team experience/hours.
- Provide an organization chart which depicts the proposed organization of the team involved with these services, including reporting relationships to the Department’s Project Manager and supervision of project team staff.

4. Project Approach and Work Plan

Provide a narrative which shows your firm’s understanding of the project’s requirements and documents a logical technical approach to the project scope of work. Include a general work plan as well as the proposed approach to undertaking the scope of work described earlier in this RFP.

- If specific project team members or vendors are critical to specific tasks, identify where they will be utilized and/or committed.
- Identify appropriate assumptions and considerations that could impact the scope and timeline for completing each task.
- Provide a detailed equipment list for each application area with associated costs.
- Provide a detailed list of estimated expenses by category. Identify related considerations and assumptions for these expenses.

5. Management and Invoicing

Describe how your firm intends to manage all aspects of the work to be performed, including schedules for completion of tasks/subtasks, procedures for scheduling and cost control. The Project management proposal must include:

- Regularly scheduled project team meetings.
- Daily written progress reports.
- Issue/risk management techniques.
- Invoicing system to support work conducted and all associated equipment.

6. Cost

Provide all pricing and cost information for all proposed services referenced in Section 2.2 – Project Scope of Work as follows, including all relevant unit costs, time increments (per hr./day), and/or flat rates for all proposed team members:

Regular Hours

Per 8 hour day shift, per diving team, Monday-Friday

Per Day/Shift, Per Team \$ _____ \$ _____

Per Hour for less than an 8 hour shift

Per Hour/Per Team \$ _____ \$ _____

Overtime/Weekend/Holiday:

Per Hour for hours worked in addition to 8 hour day shift, Monday-Friday

Overtime: Per Hour, Per Team \$_____ \$_____

Weekend: Per Day for Saturday, Sunday - Per Day/Per Team \$_____ \$_____

Holiday: Per Day for holidays. - Per Day/Per Team \$_____ \$_____

Hull cleaning charge – Per Hour \$_____

Rate to be charged, in addition to diving team Per Day/Shift rate, for diving from 50 to 100 feet, per foot of depth, per day: \$_____

State daily rates applicable to the following items of equipment:

1. Hydraulic saw and power source
2. Hydraulic drill and power source
3. Air lift – 8" diameter PVC pipe with 150 linear feet of air supply hose
4. 5,000 lb. lift bags
5. 8" educator with 20" discharge hose (pump by Harbor Department)
6. Hydraulic jack hammer and power source
7. Underwater color digital camera with flash capability
8. Complete digital recording system, with underwater camera, audio, and deck monitor
9. High pressure water blaster equipment (rated at 10,000 PSI) with pump, hoses and power source for hydraulic displacement of marine growth
10. 300 amp welding unit with oxygen and leads
11. Portable generator, rated output 110 volts

State daily rates applicable to any other equipment relevant to providing diving services that should be mentioned and which are not included above.

7. Safety Program

Provide a copy of the company's current safety policy, including a description of current safety programs and practices. Please submit any accident reports from the prior four years.

8. Photographs of Equipment

Provide labeled color photographs (minimum size 4" x 6") showing the primary and as-needed dive team's dive boat, working punt or float, dive suit with hard hat helmet, and listed equipment.

9. Business Enterprise Programs and Contract Administrative Requirements

MUST be included with your proposal:

A) SMALL/VERY SMALL BUSINESS ENTERPRISE AND LOCAL BUSINESS PREFERENCE PROGRAMS (EXHIBIT B)

Provide with your proposal the Small/Very Small Business Enterprise and Local Business Preference Programs Affidavit and Consultant Description forms (Exhibit B), fully filled out for your firm and any proposed subconsultants. Please refer to Exhibit B for detailed information relative to these programs and instructions on completing the forms.

Although there is not a mandatory Small Business Enterprise (SBE) participation requirement for this contract opportunity, Exhibit B must be submitted with your proposal.

Firms must be certified as SBEs or Very Small Business Enterprises (VSBE) through RAMP at the time proposals are due. **Firms will only receive credit for SBE/VSBE certifications reflected on their RAMP profile.** Firms may certify as SBE (Proprietary) and VSBE (Harbor) by completing the SBE (Proprietary) application (Exhibit C). Please refer to the Road Map in Exhibit C for a listing of agency certifications that may be accepted in lieu of completing the application. For VSBE certification, you must complete the application or be certified as a Micro-business through the State of California Department of General Services (DGS). If your firm is certified by one of the listed agencies, you must complete the instructions in the application in regards to obtaining certification on RAMP. Applications should be mailed to the following address referencing the RFP:

CITY OF LOS ANGELES
DEPARTMENT OF PUBLIC WORKS
Bureau of Contract Administration
Office of Contract Compliance – Centralized Certification Administration
1149 S. Broadway, Ste. 300
Los Angeles, CA 90015

Proposers who qualify as a Local Business Enterprise (LBE) will receive an 8% preference on any services valued in excess of \$150,000.

B) INSURANCE VERIFICATION LETTER

Provide a letter from your insurance carrier or broker indicating that the insurance requirements for this project as described in this RFP are presently part of the proposer's coverage, or that the insurance company is able to provide such coverage should the proposer be selected. The insurance carrier/broker must be aware of the indemnification requirements also set forth in this RFP. Proposers are not required to purchase the required insurance in order to respond; however, all required insurance will need to be submitted at the time of contract award. **ACORD® Certificate of Liability Insurance sheets will not be accepted in lieu of an insurance verification letter. Proposals submitted without an insurance verification letter, as described above, will be deemed non-responsive.**

C) CITY ETHICS COMMISSION (CEC) FORMS 50 and 55

Proposers who submit a response to this solicitation (proposers) are subject to Charter section 470 (c) (12) and related ordinances. As a result, proposers may not make campaign contributions to and or engage in fundraising for certain elected City officials or

candidates for elected City office from the time they submit the response until either the contract is approved or, for successful proposers, 12 months after the contract is signed. The proposer's principals and subcontractors performing \$100,000 or more in work on the contract, as well as the principals of those subcontractors, are also subject to the same limitations on campaign contributions and fundraising.

Proposers must submit CEC Forms 50 and 55 to the awarding authority at the same time the response is submitted (See Exhibit G). The forms require proposers to identify their principals, their subcontractors performing \$100,000 or more in work on the contract, and the principals of those subcontractors. Proposers must also notify their principals and subcontractors in writing of the restrictions and include the notice in contracts with subcontractors. Responses submitted without completed CEC Forms 50 and 55 may be deemed non-responsive. Proposers who fail to comply with City law may be subject to penalties, termination of contract, and debarment. Additional information regarding these restrictions and requirements may be obtained from the City Ethics Commission at (213) 978-1960 or ethics.lacity.org.

D) IRAN CONTRACTING ACT OF 2010

In accordance with California Public Contract Code Sections 2200-2208, all proposers submitting proposals for, entering into, or renewing contracts with the Harbor Department for goods and services estimated at \$1,000,000 or more are required to complete, sign, and submit the Iran Contracting Act of 2010 Compliance Affidavit (See Exhibit H).

E) ACCEPTANCE OF STANDARD CONTRACT PROVISIONS AND EXECUTIVE DIRECTIVE 35

Proposers are advised that pursuant to Executive Directive (ED) 35, if your firm is a for-profit company or corporation and is selected for award, you shall, within 30 days of the effective date of the contract and on an annual basis thereafter (i.e., within 30 days of the anniversary of the effective date of the contract), report the following information to the City via the Regional Alliance Marketplace for Procurement (RAMP) or via another method specified by the City:

- Annual revenue
- Number of employees
- Location
- Industry
- Race/ethnicity and gender of majority owner

On an annual basis, the consultant shall further request that any subconsultant input or update its business profile, with the above information, on RAMP or via another method prescribed by City.

Proposers must submit a signed letter confirming their intention to comply with the RAMP demographic reporting requirements of ED 35, and their firm's acceptance of all of the Standard Contract Provisions exactly as set forth in Section 4. Do not submit your

demographic information in the letter; only the selected consultant needs to enter that information into RAMP, after contract award.

3.5 Checklist for RFP Submittal Requirements

A checklist is provided to assist in verification that all elements of the RFP have been addressed. However, firms are encouraged to review the entirety of the RFP, including the Standard Contract Provisions section, to ensure full compliance and not rely solely on this checklist.

- Cover transmittal letter, signed by an authorized principal of the proposing consulting firm.
- Table of Contents, if included (not required).
- Proposal with the following sections, in order:
 - Firm Qualifications, Experience and References
 - Attachment 3-Contractor's Resume
 - Attachment 4-Contractors Employee Resume
 - Organization, Personnel and Staffing
 - Project Approach and Work Plan
 - Project Management and Invoicing
 - Cost
 - Safety Program and Accident Reports
 - Photographs of Equipment
- Small/Very Small Business Enterprise and Local Business Preference Program forms:
 - Affidavit of Company Status (**Prime**)
 - Consultant Description Form (**Prime and any subconsultants**)
- Letter from insurance carrier or broker indicating ability to meet insurance requirements for this project, including general liability, auto liability, ocean marine liability, and workers' compensation. **Do not submit an ACORD® Certificate of Liability Insurance sheet. It will not be accepted in lieu of an insurance verification letter.**
- CEC Form 50 (Bidder Certification)
- CEC Form 55 (Prohibited Contributors (Bidders))
- Iran Contracting Act of 2010 Compliance Affidavit
- Letter of acceptance of Standard Contract Provisions and Executive Directive 35

4. STANDARD CONTRACT PROVISIONS

The following sections are standard contract provisions for the Harbor Department. In submitting a proposal, proposer agrees to accept these terms without change. **If your firm cannot agree to the following requirements, exactly as set forth below, please do not submit a proposal.**

4.1 Affirmative Action

Consultant, during the performance of the Agreement, shall not discriminate in its employment practices against any employee or applicant for employment because of the employee's or applicant's race, religion, national origin, ancestry, sex, age, sexual orientation, disability, marital status, domestic partner status, or medical condition. The provisions of Section 10.8.4 of the Los Angeles Administrative Code shall be incorporated and made a part of the agreement. All subcontracts awarded shall contain a like nondiscrimination provision. See Exhibit A.

4.2 Small/Very Small Business Enterprise Program and Local Business Preference Programs

It is the policy of the Department to provide Small Business Enterprises (SBE), Very Small Business Enterprises (VSBE), Minority-Owned, Women-Owned, Disabled Veteran-Owned and all Other Business Enterprises (MBE/WBE/DVBE/OBE) an equal opportunity to participate in the performance of all City contracts in all areas where such contracts afford such participation opportunities. Consultant shall assist the City in implementing this policy and shall use its best efforts to afford the opportunity for SBEs, VSBEs, MBEs, WBEs, DVBEs, and OBEs to achieve participation in subcontracts where such participation opportunities present themselves and attempt to ensure that all available business enterprises, including SBEs, VSBEs, MBEs, WBEs, DVBEs, and OBEs, have equal participation opportunity which might be presented under this Agreement. See Exhibit B.

It is also the policy of the Department to support an increase in local and regional jobs. The Department's Local Business Preference Program aims to benefit the Southern California region by increasing jobs and expenditures within the local and regional private sector. Consultant shall assist the City in implementing this policy and shall use its best efforts to afford the opportunity for Local Business Enterprises to achieve participation in subcontracts where such participation opportunities present themselves. See Exhibit B.

NOTE: Prior to being awarded a contract with the Harbor Department, all consultants and subconsultants must be registered on the City's Contracts Management and Opportunities Database, Regional Alliance Marketplace for Procurement (RAMP), at <http://www.RAMPLA.org>. Consultant shall comply with all RAMP reporting requirements set forth in Executive Directive No. 35 (August 25, 2022), Equitable Access to Contracting Opportunities, during the term of this Agreement.

4.3 Business Tax Registration Certificate

The City of Los Angeles, Office of Finance requires the implementation and enforcement of Los Angeles Municipal Code Section 21.09 et seq. This section provides that every person, other than a municipal employee, who engages in any business within the City of Los Angeles, is required to obtain the necessary Business Tax Registration Certificate and pay business taxes. The City Controller has determined that this Code Section applies to consulting firms that are doing work for the Los Angeles Harbor Department. See Exhibit D.

4.4 Indemnity and Insurance Requirements

REQUIRED AT PROPOSAL STAGE: A letter from each proposer's carrier or broker must be provided with their proposal. The letter should indicate that the requirements below are presently part of the proposer's coverage, or that the carrier/broker is able to provide such coverage should the proposer be selected. The carrier/broker must be aware of the indemnification requirements below. Proposers are not required to purchase the required insurance in order to respond, however all required insurance will need to be submitted at the time of contract award. **ACORD® certificates will not be accepted.**

1. Indemnification

Except for the sole negligence or willful misconduct of the City, or any of its Boards, Officers, Agents, Employees, Assigns and Successors in Interest, Contractor undertakes and agrees to defend, indemnify and hold harmless the City and any of its Boards, Officers, Agents, Employees, Assigns, and Successors in Interest from and against all suits and causes of action, claims, losses, demands and expenses, including, but not limited to, attorney's fees (both in house and outside counsel) and cost of litigation (including all actual litigation costs incurred by the City, including but not limited to, costs of experts and consultants), damages or liability of any nature whatsoever, for death or injury to any person, including Contractor's employees and agents, or damage or destruction of any property of either party hereto or of third parties, arising in any manner by reason of the negligent acts, errors, omissions or willful misconduct incident to the performance of this Contract by Contractor or its subcontractors of any tier. Rights and remedies available to the City under this provision are cumulative of those provided for elsewhere in this Contract and those allowed under the laws of the United States, the State of California, and the City.

2. Acceptable Evidence and Approval of Insurance

Electronic submission is the required method of submitting insurance documents. Consultant's insurance broker or agent shall register with the City's online insurance compliance system **KwikComply** at <http://kwikcomply.org> and follow the instructions to register and submit the appropriate proof of insurance on Consultant's behalf.

Carrier Requirements

All insurance which Consultant is required to provide pursuant to this Agreement shall be placed with insurance carriers authorized to do business in the State of California and which are rated A-, VII or better in Best's Insurance Guide. Carriers without a Best's rating shall meet comparable standards in another rating service acceptable to City.

Primary Coverage

The coverages submitted must be primary with respect to any insurance or self insurance of the City of Los Angeles Harbor Department. The City of Los Angeles Harbor Department's program shall be excess of this insurance and non-contributing.

Notice Of Cancellation

For each insurance policy described below, the Consultant shall give the Board of Harbor Commissioners a 10-days prior notice of cancellation or reduction in coverage for nonpayment of premium, and a 30-days prior notice of cancellation or reduction in coverage for any other reason, by written notice via registered mail and addressed to the City of Los Angeles Harbor Department, Attention Risk Manager and the City Attorney's Office, 425 S. Palos Verdes Street, San Pedro, California 90731.

Modification of Coverage

Executive Director, at his or her discretion, based upon recommendation of independent insurance consultants to City, may increase or decrease amounts and types of insurance coverage required hereunder at any time during the term hereof by giving ninety (90) days' written notice to Consultant.

Renewal of Policies

At least thirty (30) days prior to the expiration of any policy, Consultant shall direct their insurance broker or agent to submit to the City's online insurance compliance system **KwikComply** at <http://kwikcomply.org> a renewal certificate showing that the policy has been renewed or extended or, if new insurance has been obtained, evidence of insurance as specified below. If Consultant neglects or fails to secure or maintain the insurance required below, Executive Director may, at his or her own option but without any obligation, obtain such insurance to protect the City's interests. The cost of such insurance will be deducted from the next payment due Consultant.

Policy Copies

Upon request by City, Consultant shall furnish a copy of the binder of insurance and/or full certified policy for any insurance policy required herein. This requirement shall survive the termination or expiration of this Agreement.

Limits of Coverage

If the Consultant maintains higher limits than the minimums shown below, City requires and shall be entitled to coverage for the higher limits maintained by the Consultant. Any available insurance proceeds in excess of the specified minimum limits of insurance and coverage shall be available to City.

Right to Self-Insure

Upon written approval by Executive Director, Consultant may self-insure if the

following conditions are met:

- a. Consultant has a formal self-insurance program in place prior to execution of this Agreement. If a corporation, Consultant must have a formal resolution of its board of directors authorizing self-insurance.
- b. Consultant agrees to protect the City, its boards, officers, agents and employees at the same level as would be provided by full insurance with respect to types of coverage and minimum limits of liability required by this Agreement.
- c. Consultant agrees to defend the City, its boards, officers, agents and employees in any lawsuit that would otherwise be defended by an insurance carrier.
- d. Consultant agrees that any insurance carried by Department is excess of Consultant's self-insurance and will not contribute to it.
- e. Consultant provides the name and address of its claims administrator.
- f. Consultant submits its most recently filed 10-Q and its 10-K or audited annual financial statements for the three most recent fiscal years prior to the Executive Director's consideration of approval of self-insurance and annually thereafter.
- g. Consultant agrees to inform Department in writing immediately of any change in its status or policy which would materially affect the protection afforded Department by this self-insurance.
- h. Consultant has complied with all laws pertaining to self-insurance.

Insurance

In addition to and not as a substitute for, or limitation of, any of the indemnity obligations imposed by [Indemnification Section Above], Consultant shall procure and maintain at its sole cost and expense and keep in force during the term of this Agreement the following insurance:

3. General Liability Insurance

Consultant shall procure and maintain in effect throughout the term of this Agreement, without requiring additional compensation from the City, commercial general liability insurance covering personal and advertising injury, bodily injury, and property damage providing contractual liability, independent contractors, products and completed operations, and premises/operations coverage written by an insurance company authorized to do business in the State of California rated VII, A- or better in Best's Insurance Guide (or an alternate guide acceptable to City if Best's is not available) within Consultant's normal limits of liability but not less than Five Million Dollars (\$5,000,000) combined single limit for injury or claim. Where Consultant provides or dispenses alcoholic beverages, Host Liquor Liability coverage shall be provided as above. Where Consultant provides pyrotechnics,

Pyrotechnics Liability shall be provided as above. Said limits shall provide first dollar coverage except that Executive Director may permit a self-insured retention or self-insurance in those cases where, in his or her judgment, such retention or self-insurance is justified by the net worth of Consultant. The retention or self-insurance provided shall provide that any other insurance maintained by Department shall be excess of Consultant's insurance and shall not contribute to it. In all cases, regardless of any deductible or retention, said insurance shall contain a defense of suits provision and a severability of interest clause. Additionally, each policy shall include an additional insured endorsement (CG 2010 or equivalent) naming the City of Los Angeles Harbor Department, its officers, agents and employees as Primary additional insureds.

Where Consultant's operations involve work within 50 feet of railroad track, Consultant's Commercial General Liability coverage shall also have the railroad exclusion deleted.

4. Automobile Liability Insurance

Consultant shall procure and maintain at its expense and keep in force at all times during the term of this Agreement, automobile liability insurance written by an insurance company authorized to do business in the State of California rated VII, A- or better in Best's Insurance Guide (or an alternate guide acceptable to City if Best's is not available) within Consultant's normal limits of liability but not less than One Million Dollars (\$1,000,000) covering damages, injuries or death resulting from each accident or claim arising out of any one claim or accident. Said insurance shall protect against claims arising from actions or operations of the insured, or by its employees. Coverage shall contain a defense of suits provision. Additionally, each policy shall include an additional insured endorsement (CG 2010 or equivalent) naming the City of Los Angeles Harbor Department, its officers, agents and employees as Primary additional insureds.

5. Ocean Marine Liability

Consultant shall procure and maintain insurance against claims for injuries to persons or damages to property which may arise from or in connections with Consultant's operations. The cost of the insurance shall be borne by Consultant. The coverage shall be written by an insurance company authorized to do business in the State of California rated VII, A- or better in Best's Insurance Guide (or an alternate guide acceptable to City if Best's Rating is not available). Coverage shall include, but not be limited to:

- (i) Hull and machinery coverage up to the value of the vessel(s);
- (ii) Protection and Indemnity coverage with combined single limits of

Five Million Dollars (\$5,000,000) per occurrence for bodily injury, illness, death, loss of or damage to the property of another, and Jones Act risks or equivalent thereto internationally.

Coverage shall contain a defense of suits provision and a severability of interest clause. Each policy shall also contain an additional insured endorsement (CG 2010 or equivalent) naming the City of Los Angeles Harbor Department, its officers, agents, and employees as Primary additional insureds.

6. Workers' Compensation and Employer's Liability

Where applicable, Consultant shall comply with the provisions of Section 3700 of the California Labor code which requires every employer to be insured against liability for Workers' Compensation or to undertake self-insurance in accordance with the provisions of that Code, and that the Consultant shall comply with such provisions before commencing the performance of the tasks under this Agreement. Coverage for claims under U.S. Longshore and Harbor Workers' Compensation Act, if required under applicable law, shall be included. Consultant shall submit Workers' Compensation policies whether underwritten by the state insurance fund or private carrier, which provide that the public or private carrier waives its right of subrogation against the City in any circumstance in which it is alleged that actions or omissions of the City contributed to the accident. Such worker's compensation and occupational disease requirements shall include coverage for all employees of Consultant, and for all employees of any subcontractor or other vendor retained by Consultant.

4.5 Conflict of Interest

It is hereby understood and agreed that the parties to this Agreement have read and are aware of the provisions of Section 1090 et seq. and Section 87100 et seq. of the California Government Code relating to conflict of interest of public officers and employees, as well as the Los Angeles Municipal Code (LAMC) Municipal Ethics and Conflict of Interest provisions of Section 49.5.1 et seq. and the Conflict of Interest Codes of the City and Department. All parties hereto agree that they are unaware of any financial or economic interest of any public officer or employee of City relating to this Agreement. Notwithstanding any other provision of this Agreement, it is further understood and agreed that if such financial interest does exist at the inception of this Agreement, City may immediately terminate this Agreement by giving written notice thereof.

During the term of this Agreement, Consultant shall inform the Department when Consultant, or any of its Subconsultants, employs or hires in any capacity, and for any length of time, a person who has worked for the Department as a Commissioner, officer or employee. Said notice shall include the individual's name and current position and their prior position and years of employment with the Department. Notice shall be provided by Consultant to the Department within thirty (30) days of the employment or hiring of the individual.

4.6 Compliance with Applicable Laws

Consultant shall at all times in the performance of its obligations comply with all applicable laws, statutes, ordinances, rules and regulations, and with the reasonable requests and directions of the Executive Director.

4.7 Governing Law / Venue

This Agreement shall be governed by and construed in accordance with the laws of the State of California, without reference to the conflicts of law, rules and principles of such

State. The parties agree that all actions or proceedings arising in connection with this Agreement shall be tried and litigated exclusively in the State or Federal courts located in the County of Los Angeles, State of California, in the judicial district required by court rules.

4.8 Termination Provision

The Board of Harbor Commissioners, in its sole discretion, shall be able to terminate and cancel all or any part of the Agreement it enters into with the selected Consultant for any reason upon giving the Consultant ten (10) days' notice in writing of its election to cancel and terminate the Agreement. It is agreed that any Agreement entered into shall not limit the right of the City to hire additional Consultants to perform the services described in the Agreement either during or after the term of the Agreement.

4.9 Proprietary Information

1. Writings, as that term is defined in Section 250 of the California Evidence Code (including, without limitation, drawings, specifications, estimates, reports, records, reference material, data, charts, documents, renderings, computations, computer tapes or disks, submittals and other items of any type whatsoever, whether in the form of writing, figures or delineations), which are obtained, generated, compiled or derived in connection with this Agreement (collectively hereafter referred to as "property"), are owned by City as soon as they are developed, whether in draft or final form. City has the right to use or permit the use of property and any ideas or methods represented by such property for any purpose and at any time without compensation other than that provided in this Agreement. Consultant hereby warrants and represents that City at all times owns rights provided for in this section free and clear of all third-party claims whether presently existing or arising in the future, whether or not presently known. Consultant need not obtain for City the right to use any idea, design, method, material, equipment or other matter which is the subject of a valid patent, unless such patent is owned by Consultant or one of its employees, or its Subconsultant or the Subconsultant's employees, in which case such right shall be obtained without additional compensation. Whether or not Consultant's initial proposal or proposals made during this Agreement are accepted by City, it is agreed that all information of any nature whatsoever connected with the Scope of Work, regardless of the form of communication, which has been or may be given by Consultant, its Subconsultants or on either's behalf, whether prior or subsequent to this Agreement becoming effective, to the City, its boards, officers, agents or employees, is not given in confidence. Accordingly, City or its designees may use or disclose such information without liability of any kind, except as may arise under valid patents.

2. If research or development is furnished in connection with this Agreement and if, in the course of such research or development, patentable work product is produced by Consultant, its officers, agents, employees, or Subconsultants, the City shall have, without cost or expense to it, an irrevocable, non-exclusive royalty-free license to make and use, itself or by anyone on its behalf, such work product in connection with any activity now or hereafter engaged in or permitted by City. Upon City's request, Consultant, at its sole cost and expense, shall promptly furnish or obtain from the appropriate person a form of license satisfactory to the City. It is expressly understood and agreed that, as between City and Consultant, the referenced license shall arise for City's benefit immediately upon the production of the work product, and is not dependent on the written license specified above. City may transfer such license to its successors in the operation or ownership of any real or

personal property now or hereafter owned or operated by City.

4.10 Trademarks, Copyrights, and Patents

Consultant agrees to save, keep, hold harmless, protect and indemnify the City and any of its officers or agents from any damages, cost, or expenses in law or equity from infringement of any patent, trademark, service mark or copyright of any person or persons, or corporations in consequence of the use by City of any materials supplied by Consultant in the performance of this Agreement.

4.11 Confidentiality

The data, documents, reports or other materials which contain information relating to the review, documentation, analysis and evaluation of the work described in this Agreement and any recommendations made by Consultant relative thereto shall be considered confidential and shall not be reproduced, altered, used or disseminated by Consultant or its employees or agents in any manner except and only to the extent necessary in the performance of the work under this Agreement. In addition, Consultant is required to safeguard such information from access by unauthorized personnel.

4.12 Notices

In all cases where written notice is to be given under this Agreement, service shall be deemed sufficient if said notice is deposited in the United States mail, postage paid. When so given, such notice shall be effective from the date of mailing of the same. For the purposes hereof, unless otherwise provided by notice in writing from the respective parties, notice to the Department shall be addressed to _____, Los Angeles Harbor Department, P.O. Box 151, San Pedro, California, 90733-0151, and notice to Consultant shall be addressed to it at the address set forth above. Nothing herein contained shall preclude or render inoperative service of such notice in the manner provided by law.

4.13 Termination Due to Non-Appropriation of Funds

This Agreement is subject to the provisions of the Los Angeles City Charter which, among other things, precludes the City from making any expenditure of funds or incurring any liability, including contractual commitments, in excess of the amount appropriated thereof.

The Board, in awarding this Agreement, is expected to appropriate sufficient funds to meet the estimated expenditure of funds through June 30 of the current fiscal year and to make further appropriations in each succeeding fiscal year during the life of the Agreement. However, the Board is under no legal obligation to do so.

The City, its boards, officers, and employees are not bound by the terms of this Agreement or obligated to make payment thereunder in any fiscal year in which the Board does not appropriate funds therefore. The Consultant is not entitled to any compensation in any fiscal year in which funds have not been appropriated for the Agreement by the Board.

Although the Consultant is not obligated to perform any work under the Agreement in

any fiscal year in which no appropriation for the Agreement has been made, the Consultant agrees to resume performance of the work required by the Agreement on the same terms and conditions for a period of sixty (60) days after the end of the fiscal year if an appropriation therefore is approved by the Board within that 60 day period. The Consultant is responsible for maintaining all insurance and bonds during this 60 day period until the appropriation is made; however, such extension of time is not compensable.

If in any subsequent fiscal year funds are not appropriated by the Board for the work required by the Agreement, the Agreement shall be terminated. However, such termination shall not relieve the parties of liability for any obligation previously incurred.

4.14 Taxpayer Identification Number

The Internal Revenue Service (IRS) requires that all consultants and suppliers of materials and supplies provide a TIN to the party that pays them. Consultant declares that it has an authorized TIN which shall be provided to the Department prior to payment under the Agreement. No payments will be made under the Agreement without a valid TIN.

4.15 Service Contractor Worker Retention Policy and Living Wage Policy Requirements

The Board of Harbor Commissioners of the City of Los Angeles adopted Resolution Nos. 19-8419 and 19-8420 on January 24, 2019, adopting the provisions of Los Angeles City Ordinance No. 185356, relating to Service Contractor Worker Retention (SCWR), Section 10.36 et seq. of the Los Angeles Administrative Code, as the policy of the Department. Further, Charter Section 378 requires compliance with the City's Living Wage requirements as set forth by ordinance, Section 10.37 et seq. of the Los Angeles Administrative Code. Consultant shall comply with the policy wherever applicable. Violation of this provision, where applicable, shall entitle the City to terminate this Agreement and otherwise pursue legal remedies that may be available.

4.16 Wage and Earnings Assignment Orders/Notices of Assignments

Consultant and/or any subconsultant are obligated to fully comply with all applicable state and federal employment reporting requirements for the Consultant and/or subconsultant's employees.

Consultant and/or subconsultant shall certify that the principal owner(s) are in compliance with any Wage and Earnings Assignment Orders and Notices of Assignments applicable to them personally. Consultant and/or subconsultant will fully comply with all lawfully served Wage and Earnings Assignment Orders and Notices of Assignments in accordance with Cal. Family Code § 5230 et seq. Consultant or subconsultant will maintain such compliance throughout the term of the Agreement.

4.17 Equal Benefits Policy

The Board of Harbor Commissioners of the City of Los Angeles adopted Resolution

No. 6328 on January 12, 2005, agreeing to adopt the provisions of Los Angeles City Ordinance 172,908, as amended, relating to Equal Benefits, Section 10.8.2.1 et seq. of the Los Angeles Administrative Code, as a policy of the Harbor Department. Consultant shall comply with the policy wherever applicable. Violation of the policy shall entitle the City to terminate any Agreement with Consultant and pursue any and all other legal remedies that may be available. See Exhibit E.

4.18 State Tidelands Grants

The Agreement will be entered into in furtherance of and as a benefit to the State Tidelands Grant and the trust created thereby. Therefore, the Agreement will at all times be subject to the limitations, conditions, restrictions and reservations contained in and prescribed by the Act of the Legislature of the State of California entitled "An Act Granting to the City of Los Angeles the Tidelands and Submerged Lands of the State Within the Boundaries of Said City," approved June 3, 1929, (Stats. 1929, Ch. 651), as amended, and provisions of Article VI of the Charter of the City of Los Angeles relating to such lands. Consultant agrees that any interpretation of the Agreement and the terms contained therein must be consistent with such limitations, conditions, restrictions and reservations.

4.19 Contract Solicitations Charter Section 470 (c) (12)

Persons who submit a response to this solicitation (proposers) are subject to Charter section 470 (c) (12) and related ordinances. As a result, proposers may not make campaign contributions to and or engage in fundraising for certain elected City officials or candidates for elected City office from the time they submit the response until either the contract is approved or, for successful proposers, 12 months after the contract is signed. The proposer's principals and subcontractors performing \$100,000 or more in work on the contract, as well as the principals of those subcontractors, are also subject to the same limitations on campaign contributions and fundraising.

Proposers must submit CEC form 50 and 55 to the awarding authority at the same time the response is submitted (See Exhibit G). The form requires proposers to identify their principals, their subcontractors performing \$100,000 or more in work on the contract, and the principals of those subcontractors. Proposers must also notify their principals and subcontractors in writing of the restrictions and include the notice in contracts with subcontractors. Responses submitted without a completed CEC Form 55 may be deemed nonresponsive. Proposers who fail to comply with City law may be subject to penalties, termination of contract, and debarment. Additional information regarding these restrictions and requirements may be obtained from the City Ethics Commission at (213) 978-1960 or ethics.lacity.org.

4.20 Iran Contracting Act of 2010

The California Legislature adopted the Iran Contracting Act of 2010 to respond to policies of Iran in a uniform fashion (PCC § 2201(q)). The Iran Contracting Act prohibits proposers engaged in investment activities in Iran from submitting proposals for, or entering into or renewing contracts with public entities for goods and services of one million dollars (\$1,000,000) or more (PCC § 2203(a)). In accordance with California Public Contract Code

Sections 2200-2208, all proposers submitting proposals for, entering into, or renewing contracts with the Harbor Department for goods and services estimated at \$1,000,000 or more are required to complete, sign, and submit the Iran Contracting Act of 2010 Compliance Affidavit (See Exhibit H).

4.21 Recordkeeping And Audit Rights

A. Consultant shall keep and maintain full, complete and accurate books of accounts and records of the services performed under this Agreement in accordance with generally accepted accounting principles consistently applied, which books and records shall be readily accessible to and open for inspection and copying at the premises by City, its auditors or other authorized representatives. Notwithstanding any other provision of this Agreement, failure to do so shall constitute a conclusive waiver of any right to compensation for such services as are otherwise compensable hereunder. Such books and records shall be maintained by Consultant for a period of three (3) years after completion of services to be performed under this Agreement or until all disputes, appeals, litigation or claims arising from this Agreement have been resolved.

B. During the term of this Agreement, City may audit, review and copy any and all writings (as that term is defined in Section 250 of the California Evidence Code) of Consultant and Subconsultants arising from or related to this Agreement or performance of the Scope of Work, whether such writings are (a) in final form or not, (b) prepared by Consultant, Subconsultants or any individual or entity acting for or on behalf of Consultant or a Subconsultant, and (c) without regard to whether such writings have previously been provided to City. Consultant shall be responsible for obtaining access to and providing writings of Subconsultants. Consultant shall provide City at Consultant's sole cost and expense a copy of all such writings within fourteen (14) calendar days of a written request by City. City's right shall also include inspection at reasonable times of the Consultant's office or facilities which are engaged in the performance of the Scope of Work. Consultant shall, at no cost to City, furnish reasonable facilities and assistance for such review and audit. Consultant's failure to comply with this Article 6 shall constitute a material breach of this Agreement and shall entitle City to withhold any payment due under this Agreement until such breach is cured.

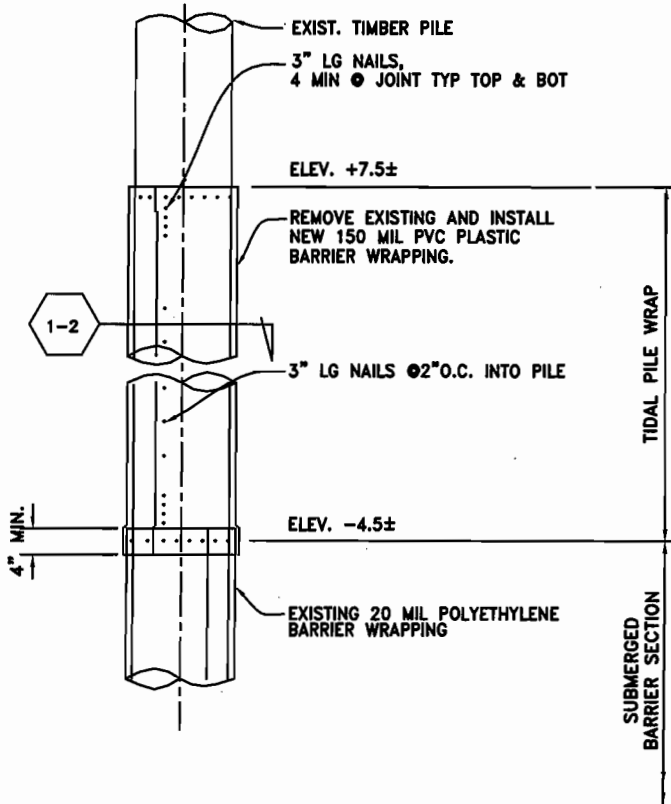

TIDAL WRAP
ELEVATION - RECONSTRUCTION
OF EXISTING FENDER PILE WRAPPING
NEW FENDER PILE WRAPPING, SIMILAR

1-1

SCALE: NTS

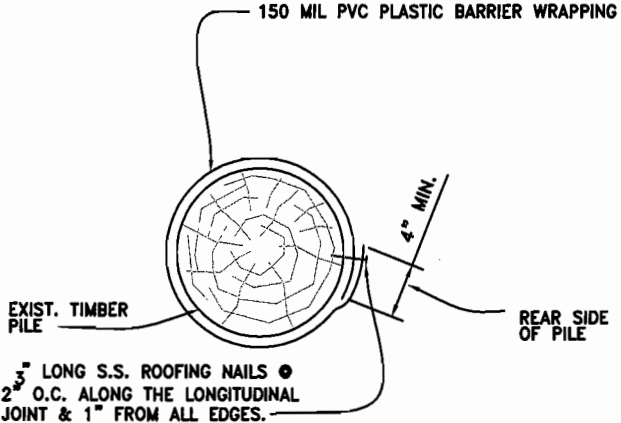

NOTE:
THE WRAPPING SHALL BE UNIFORM & CONTINUOUS THROUGHOUT THE RECONSTRUCTION LENGTH OF PILE RESULTING IN A SMOOTH, WRINKLE FREE, AIRTIGHT FIT.

1-2 SECTION - 150mil PVC PILE WRAP
SCALE: NTS

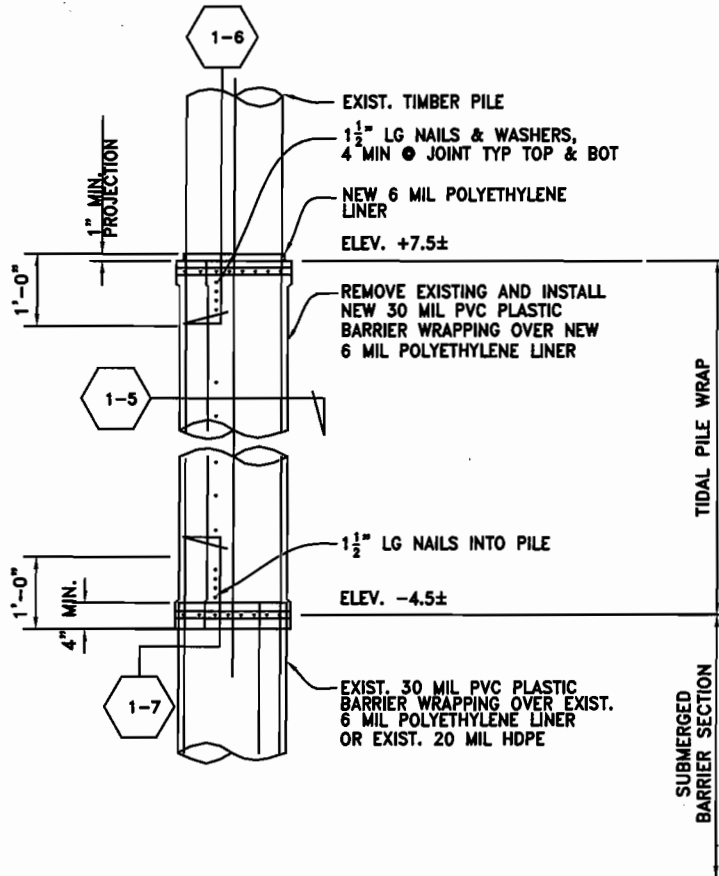

NOTE: DETAILS 1-1 TO 1-6 SHOWN FOR EITHER REPAIR OR REPLACEMENT OF EXIST WRAPPING.

TIDAL WRAP
ELEVATION - RECONSTRUCTION
OF EXISTING PILE WRAPPING
NEW PILE WRAPPING, SIMILAR

1-3

SCALE: NTS

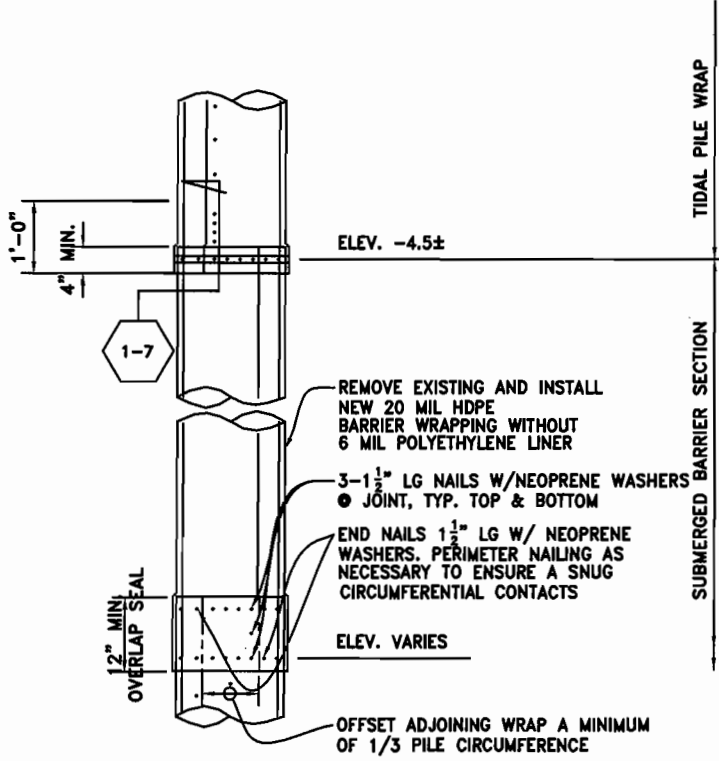

SUBMERGED WRAP
ELEVATION - RECONSTRUCTION
OF EXISTING PILE WRAPPING
NEW PILE WRAPPING, SIMILAR

1-4

SCALE: NTS

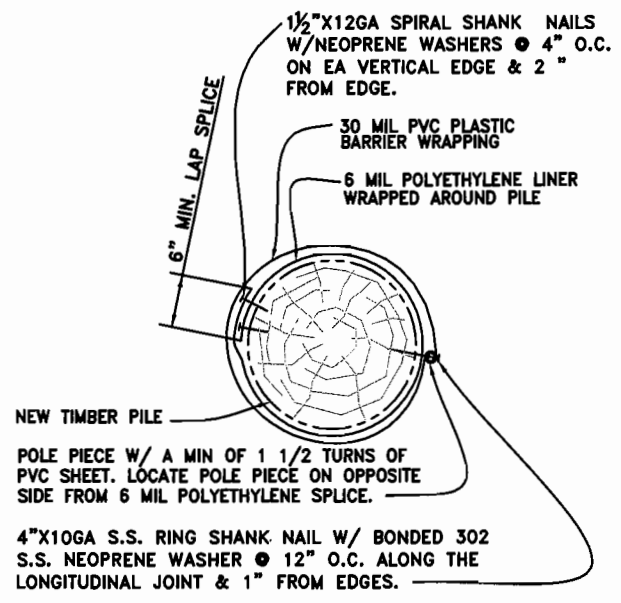

NOTE:

1. PRE-WRAP PILE WITH 6 MIL POLYETHYLENE LINER AS TIGHTLY AS POSSIBLE BEFORE DRIVING PILE.
2. THE WRAPPING SHALL BE UNIFORM & CONTINUOUS THROUGHOUT THE RECONSTRUCTION LENGTH OF PILE RESULTING IN A SMOOTH, WRINKLE FREE, AIRTIGHT FIT.
3. DO NOT EMBED HEAD OF 4" NAIL INTO PLASTIC WRAPPING

1-5 SECTION - 30mil PVC PILE WRAP
SCALE: NTS

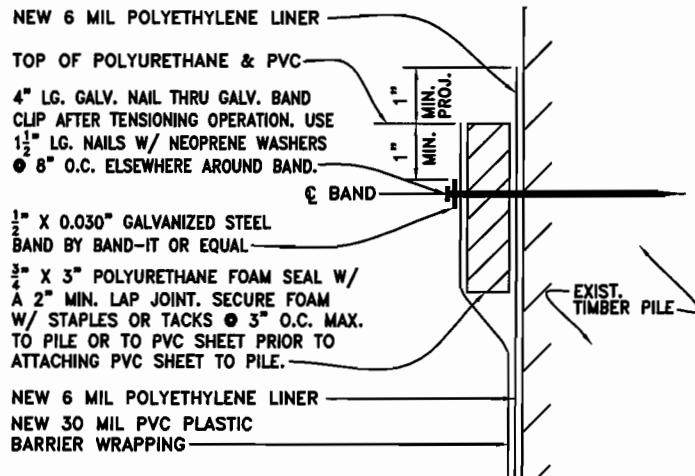

NOTE:
BANDING:
 BANDS SHALL BE INSTALLED USING A "SIGNADE" STRETCHER OR EQUIVALENT TOOL TO PROVIDE ADEQUATE BAND TENSION FOR MAXIMUM COMPRESSION OF FOAM.

SECTION - UPPER BAND
 INTERTIDAL WRAPPING
 1-6
 SCALE: NTS

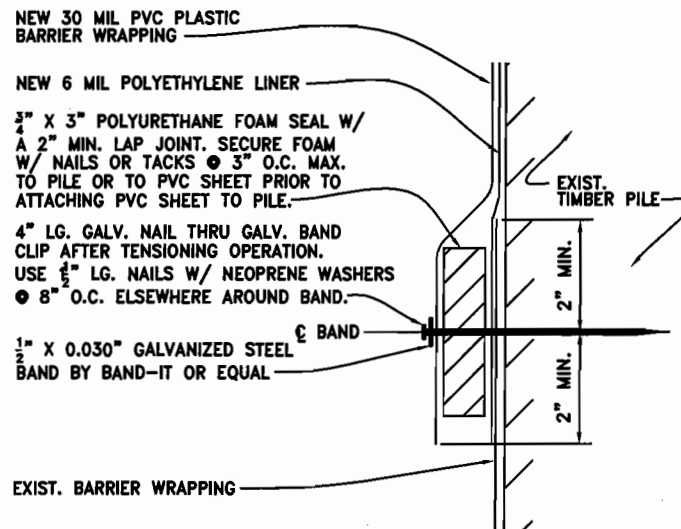

SECTION - LOWER BAND
 INTERTIDAL WRAPPING
 1-7
 SCALE: NTS

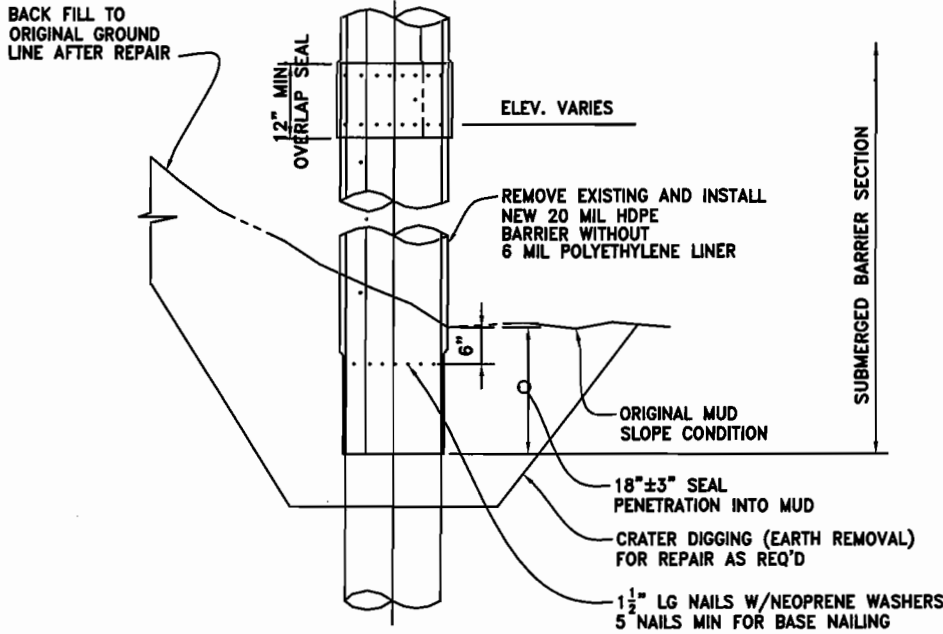

MUD SEAL REPAIR NOTES:

1. CRATER DIGGING SHALL BE DONE MANUALLY.
2. AFTER WRAPPING, BACK FILL CRATER WITH MUD TO ORIGINAL ELEVATION.
3. REMOVE ANY ROCK PRIOR TO PILE WRAPPING.

**ROCKLINE WRAP
ELEVATION - RECONSTRUCTION
OF EXISTING PILE WRAPPING
NEW PILE WRAPPING, SIMILAR**

1-8

SCALE: NTS

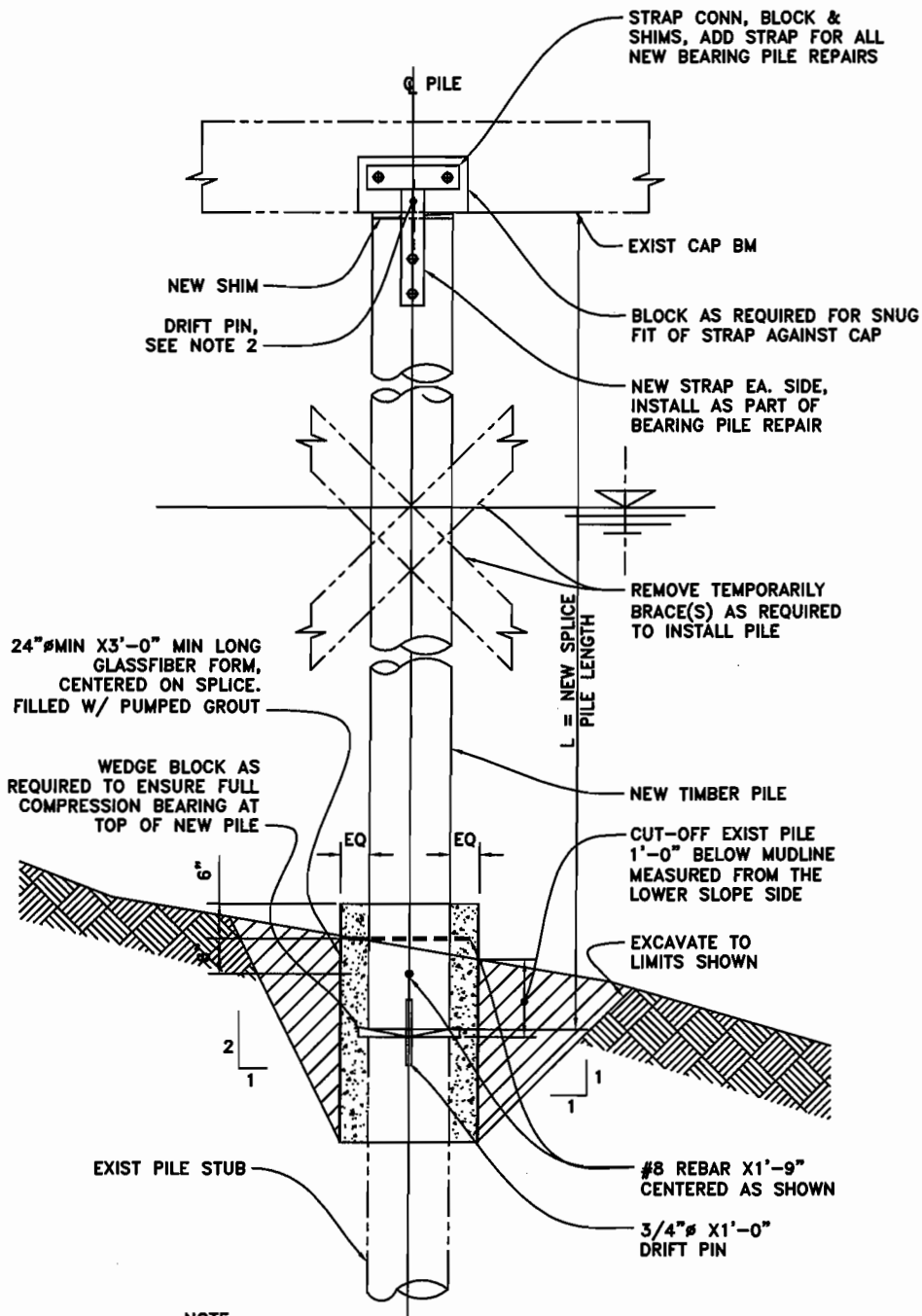

NOTE:

1. ALL NEW BEARING PILES SHALL BE WRAPPED PER 1-3 TO 1-8.
2. DRIFT PINS MAY BE ENCOUNTERED. REMOVE PIN WHERE OCCURS.

Attachment 2

LOS ANGELES HARBOR AND VICINITY

NUMBERS IN SQUARE:
DEPTH OF WATER BELOW MEAN LOWER LOW WATER

15.5	METERS
51	FEET

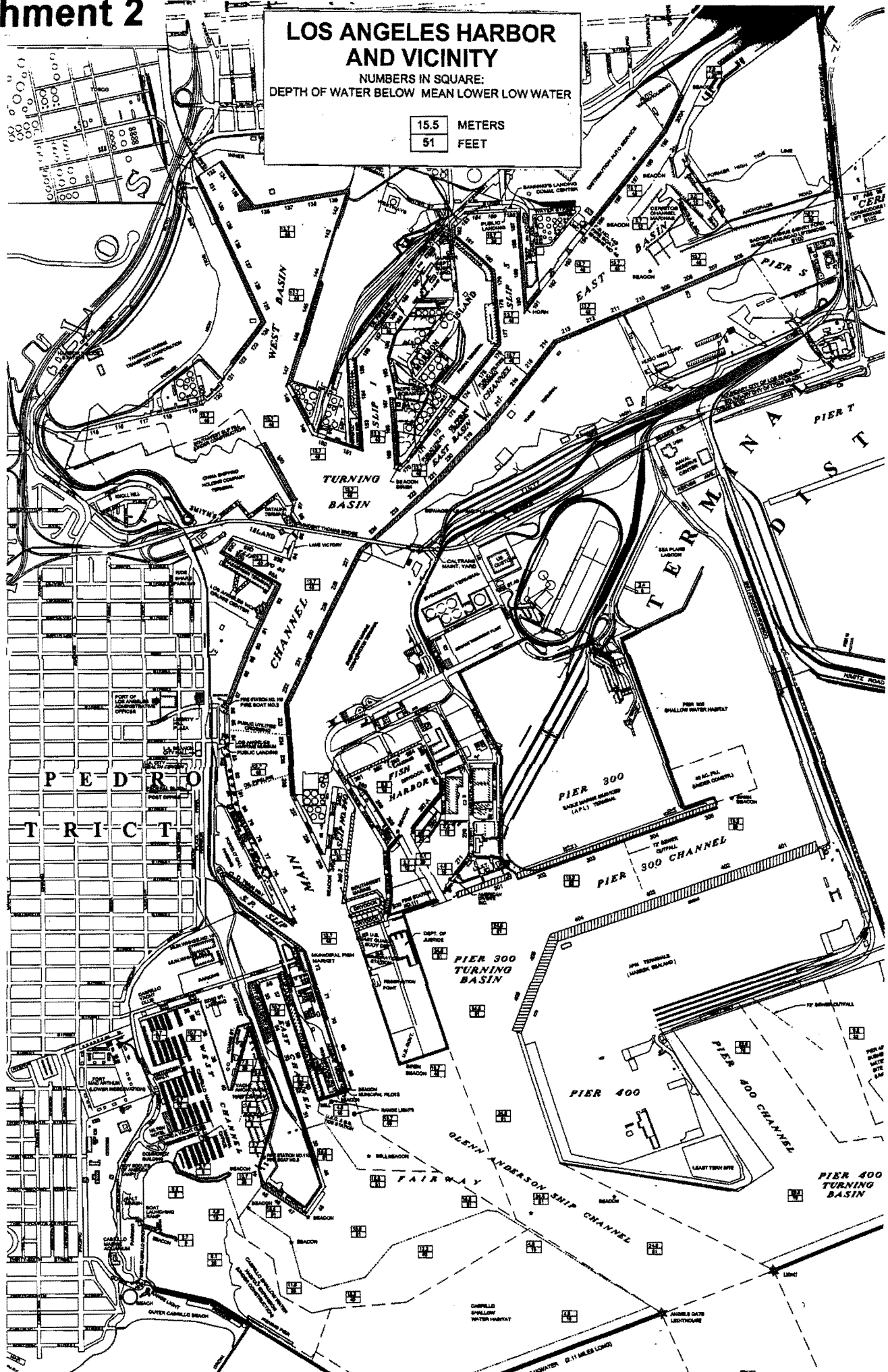

**ATTACHMENT 3
CONTRACTOR'S RESUME**

State Name of Company: _____

State of California Class "A" License No. and Expiration Date:

Name & Address of Client/Company for Which Services Were Provided:

**Company Contact – Include Individual's Name, Title, Phone Number, E-mail
Address:**

Project Description (services provided & outcome)

Project Start Date Project Completion Date Number of Working Days

____/____/____
(MM/DD/YR)

____/____/____
(MM/DD/YR)

Dollar Amount of Project: \$ _____

Number of Employees (by Classification) & Dive Teams Used on Project:

Equipment Used on Project & Percentage of Time Used on Project:

_____	_____ %
_____	_____ %
_____	_____ %

Use of Alternative Fuel Equipment - Please identify your ability to use alternative fuel equipment in providing your services to the Port through this contract:

**ATTACHMENT 4
CONTRACTOR'S EMPLOYEE RESUME**

Contractor's Employee Experience: Using this two-page Employee Resume Form, state your proposed dive teams experience in the past four (4) years performing hard hat diving services similar to those described under the scope of this RFP. You will need to make additional copies to use as necessary to cover each of your employees.

Employee Name

Position/Title

Education & Training (including Commercial Diving School, Epoxy Materials, or Equipment Training):

Licenses/Certifications: _____ (Please provide copies of documents)

Work Experience:

(1) Dates of Employment: From _____ To _____
(MO/YR) (MO/YR)

(2) Employer (Name, Address, Telephone No., E-mail address):

(3) Immediate Supervisor's Name/Title:

(4) Description of Project(s):

(5) Employee's Duties:

(6) Equipment & Tools Used:

(7) Total Diving Days/Working Hours:

(8) Other Work Experience:

EXHIBIT A - AFFIRMATIVE ACTION PROGRAM PROVISIONS

Sec. 10.8.4 Affirmative Action Program Provisions.

Every non-construction and construction Contract with, or on behalf of, the City of Los Angeles for which the consideration is \$25,000 or more shall contain the following provisions which shall be designated as the AFFIRMATIVE ACTION PROGRAM provisions of such Contract:

A. During the performance of a City Contract, the Contractor certifies and represents that the Contractor and each Subcontractor hereunder will adhere to an Affirmative Action Program to ensure that in its employment practices, persons are employed and employees are treated equally and without regard to or because of race, color, religion, national origin, ancestry, sex, sexual orientation, age, disability, marital status, domestic partner status or medical condition.

1. This section applies to work or services performed or materials manufactured or assembled in the United States.

2. Nothing in this section shall require or prohibit the establishment of new classifications of employees in any given craft, work or service category.

3. The Contractor shall post a copy of Paragraph A., hereof, in conspicuous places at its place of business available to employees and applicants for employment.

B. The Contractor shall, in all solicitations or advertisements for employees placed, by or on behalf of, the Contractor, state that all qualified applicants will receive consideration for employment without regard to their race, color, religion, national origin, ancestry, sex, sexual orientation, age, disability, marital status, domestic partner status or medical condition.

C. At the request of the Awarding Authority or the DAA, the Contractor shall certify on an electronic or hard copy form to be supplied, that the Contractor has not discriminated in the performance of City Contracts against any employee or applicant for employment on the basis or because of race, color, religion, national origin, ancestry, sex, sexual orientation, age, disability, marital status, domestic partner status or medical condition.

D. The Contractor shall permit access to, and may be required to provide certified copies of, all of its records pertaining to employment and to its employment practices by the Awarding Authority or the DAA for the purpose of investigation to ascertain compliance with the Affirmative Action Program provisions of City Contracts and, upon request, to provide evidence that it has or will comply therewith.

E. The failure of any Contractor to comply with the Affirmative Action Program provisions of City Contracts may be deemed to be a material breach of a City Contract. The failure shall only be established upon a finding to that effect by the Awarding Authority, on the basis of its own investigation or that of the DAA. No finding shall be made except upon a full and fair hearing after notice and an opportunity to be heard has been given to the Contractor.

F. Upon a finding duly made that the Contractor has breached the Affirmative Action Program provisions of a City Contract, the Contract may be forthwith cancelled, terminated or suspended, in whole or in part, by the Awarding Authority, and all monies due or to become due hereunder may be forwarded to and retained by the City of Los Angeles. In addition thereto, the breach may be the basis for a determination by the Awarding

Authority or the Board of Public Works that the Contractor is a non-responsible bidder or proposer pursuant to the provisions of Section 10.40 of this Code. In the event of such determination, the Contractor shall be disqualified from being awarded a contract with the City of Los Angeles for a period of two years, or until he or she shall establish and carry out a program in conformance with the provisions hereof.

G. In the event of a finding by the Fair Employment and Housing Commission of the State of California, or the Board of Public Works of the City of Los Angeles, or any court of competent jurisdiction, that the Contractor has been guilty of a willful violation of the California Fair Employment and Housing Act, or the Affirmative Action Program provisions of a City Contract, there may be deducted from the amount payable to the Contractor by the City of Los Angeles under the contract, a penalty of ten dollars for each person for each calendar day on which the person was discriminated against in violation of the provisions of a City Contract.

H. Notwithstanding any other provisions of a City Contract, the City of Los Angeles shall have any and all other remedies at law or in equity for any breach hereof.

I. The Public Works Board of Commissioners shall promulgate rules and regulations through the DAA and provide to the Awarding Authorities electronic and hard copy forms for the implementation of the Affirmative Action Program provisions of City contracts, and rules and regulations and forms shall, so far as practicable, be similar to those adopted in applicable Federal Executive Orders. No other rules, regulations or forms may be used by an Awarding Authority of the City to accomplish this contract compliance program.

J. Nothing contained in City Contracts shall be construed in any manner so as to require or permit any act which is prohibited by law.

K. By affixing its signature to a Contract that is subject to this article, the Contractor shall agree to adhere to the provisions in this article for the duration of the Contract. The Awarding Authority may also require Contractors and suppliers to take part in a pre-registration, pre-bid, pre-proposal, or pre-award conference in order to develop, improve or implement a qualifying Affirmative Action Program.

1. The Contractor certifies and agrees to immediately implement good faith effort measures to recruit and employ minority, women and other potential employees in a non-discriminatory manner including, but not limited to, the following actions as appropriate and available to the Contractor's field of work. The Contractor shall:

- (a) Recruit and make efforts to obtain employees through:
 - (i) Advertising employment opportunities in minority and other community news media or other publications.
 - (ii) Notifying minority, women and other community organizations of employment opportunities.
 - (iii) Maintaining contact with schools with diverse populations of students to notify them of employment opportunities.
 - (iv) Encouraging existing employees, including minorities and women, to refer their friends and relatives.
 - (v) Promoting after school and vacation employment opportunities for minority, women and other youth.

- (vi) Validating all job specifications, selection requirements, tests, etc.
 - (vii) Maintaining a file of the names and addresses of each worker referred to the Contractor and what action was taken concerning the worker.
 - (viii) Notifying the appropriate Awarding Authority and the DAA in writing when a union, with whom the Contractor has a collective bargaining agreement, has failed to refer a minority, woman or other worker.
- (b) Continually evaluate personnel practices to assure that hiring, upgrading, promotions, transfers, demotions and layoffs are made in a non-discriminatory manner so as to achieve and maintain a diverse work force.
 - (c) Utilize training programs and assist minority, women and other employees in locating, qualifying for and engaging in the training programs to enhance their skills and advancement.
 - (d) Secure cooperation or compliance from the labor referral agency to the Contractor's contractual Affirmative Action Program obligations.
 - (e) Establish a person at the management level of the Contractor to be the Equal Employment Practices officer. Such individual shall have the authority to disseminate and enforce the Contractor's Equal Employment and Affirmative Action Program policies.
 - (f) Maintain records as are necessary to determine compliance with Equal Employment Practices and Affirmative Action Program obligations and make the records available to City, State and Federal authorities upon request.
 - (g) Establish written company policies, rules and procedures which shall be encompassed in a company-wide Affirmative Action Program for all its operations and Contracts. The policies shall be provided to all employees, Subcontractors, vendors, unions and all others with whom the Contractor may become involved in fulfilling any of its Contracts.
 - (h) Document its good faith efforts to correct any deficiencies when problems are experienced by the Contractor in complying with its obligations pursuant to this article. The Contractor shall state:
 - (i) What steps were taken, how and on what date.
 - (ii) To whom those efforts were directed.
 - (iii) The responses received, from whom and when.
 - (iv) What other steps were taken or will be taken to comply and when.
 - (v) Why the Contractor has been or will be unable to comply.
2. Every contract of \$25,000 or more which may provide construction, demolition, renovation, conservation or major maintenance of any kind shall also comply with the requirements of Section 10.13 of the Los Angeles Administrative Code.
- L. The Affirmative Action Program required to be submitted hereunder and the pre-registration, pre-bid, pre-proposal or pre-award conference which may be required by the Awarding Authority shall, without limitation as to the subject or nature of employment activity, be concerned with such employment practices as:
- 1. Apprenticeship where approved programs are functioning, and other on-the-job training for non-apprenticeable occupations;

2. Classroom preparation for the job when not apprenticeable;
 3. Pre-apprenticeship education and preparation;
 4. Upgrading training and opportunities;
 5. Encouraging the use of Contractors, Subcontractors and suppliers of all racial and ethnic groups; provided, however, that any contract subject to this ordinance shall require the Contractor, Subcontractor or supplier to provide not less than the prevailing wage, working conditions and practices generally observed in private industries in the Contractor's, Subcontractor's or supplier's geographical area for such work;
 6. The entry of qualified women, minority and all other journeymen into the industry; and
 7. The provision of needed supplies or job conditions to permit persons with disabilities to be employed, and minimize the impact of any disability.
- M. Any adjustments which may be made in the Contractor's work force to achieve the requirements of the City's Affirmative Action Program in purchasing and construction shall be accomplished by either an increase in the size of the work force or replacement of those employees who leave the work force by reason of resignation, retirement or death and not by termination, layoff, demotion or change in grade.
- N. This ordinance shall not confer upon the City of Los Angeles or any Agency, Board or Commission thereof any power not otherwise provided by law to determine the legality of any existing collective bargaining agreement and shall have application only to discriminatory employment practices by Contractors engaged in the performance of City Contracts.
- O. All Contractors subject to the provisions of this article shall include a similar provision in all subcontracts awarded for work to be performed under the Contract with the City and shall impose the same obligations including, but not limited to, filing and reporting obligations, on the Subcontractors as are applicable to the Contractor. Failure of the Contractor to comply with this requirement or to obtain the compliance of its Subcontractors with all such obligations shall subject the Contractor to the imposition of any and all sanctions allowed by law, including, but not limited to, termination of the Contractor's Contract with the City.

EXHIBIT B

(1) SMALL/VERY SMALL BUSINESS ENTERPRISE PROGRAM

(2) LOCAL BUSINESS PREFERENCE PROGRAM

(1) SMALL/VERY SMALL BUSINESS ENTERPRISE PROGRAM:

The Harbor Department is committed to creating an environment that provides all individuals and businesses open access to the business opportunities available at the Harbor Department in a manner that reflects the diversity of the City of Los Angeles. The Harbor Department's Small Business Enterprise (SBE) Program was created to provide additional opportunities for small businesses to participate in professional service and construction contracts. An overall Department goal of 25% SBE participation, including 5% Very Small Business Enterprise (VSBE) participation, has been established for the Program. The specific goal or requirement for each contract opportunity may be higher or lower based on the scope of work.

It is the policy of the Harbor Department to solicit participation in the performance of all service contracts by all individuals and businesses, including, but not limited to, SBEs, VSBEs, women-owned business enterprises (WBEs), minority-owned business enterprises (MBEs), and disabled veteran business enterprises (DVBEs). The SBE Program allows the Harbor Department to target small business participation, including MBEs, WBEs, and DVBEs, more effectively. It is the intent of the Harbor Department to make it easier for small businesses to participate in contracts by providing education and assistance on how to do business with the City, and ensuring that payments to small businesses are processed in a timely manner. **In order to ensure the highest participation of SBE/VSBE/MBE/WBE/DVBEs, all proposers shall utilize the City's contracts management and opportunities database, the Regional Alliance Marketplace for Procurement (RAMP), at <http://www.RAMPLA.org>, to outreach to potential subconsultants.**

The Harbor Department defines a SBE as an independently owned and operated business that is not dominant in its field and meets criteria set forth by the Small Business Administration in Title 13, Code of Federal Regulations, Part 121. Go to www.sba.gov for more information. The Harbor Department defines a VSBE based on the State of California's Micro-business definition which is (1) a small business that has average annual gross receipts of \$5,000,000 or less within the previous three years, or (2) a small business manufacturer with 25 or fewer employees.

The SBE Program is a results-oriented program, requiring consultants who receive contracts from the Harbor Department to perform outreach and utilize certified small businesses. The North American Industry Classification System (NAICS) Code for the scope of services is **561990**. This NAICS Code is the industry code that corresponds to at least 51% of the scope of services and will be used to determine the size standard for SBE participation of the Prime Consultant. The maximum SBE size standard for this NAICS Code is \$16.5 million.

Consultant shall be responsible for determining the SBE status of its subconsultants for purposes of meeting the small business requirement. Subconsultants must qualify as an SBE based on the type of services that they will be performing under the Agreement. All business participation will be determined by the percentage of the total amount of compensation under the agreement paid to SBEs. The Consultant shall not substitute an SBE firm without obtaining prior approval of the City. A request for substitution must be based upon demonstrated good cause. If substitution is permitted, Consultant shall endeavor to make an in-kind substitution for the substituted SBE.

Consultant shall complete, sign and submit as part of the executed agreement the attached Affidavit and Consultant Description Form. The Affidavit and Consultant Description Form, when signed, will signify the Consultant's intent to comply with the SBE requirement. All SBE/VSBE firms must be certified by the time proposals are due to receive credit. In addition all consultants and subconsultants must be registered on the RAMP by the time proposals are due.

(2) LOCAL BUSINESS PREFERENCE PROGRAM:

The Harbor Department is committed to maximizing opportunities for local and regional businesses, as well as encouraging local and regional businesses to locate and operate within the Southern California region. It is the policy of the Harbor Department to support an increase in local and regional jobs. The Harbor Department's Local Business Preference Program (LBPP) aims to benefit the Southern California region by increasing jobs and expenditures within the local and regional private sector.

Consultants who qualify as a Local Business Enterprise (LBE) will receive an 8% preference on any proposal for services valued in excess of \$150,000. The preference will be applied by adding 8% of the total possible evaluation points to the Consultant's score.

The Harbor Department defines a LBE as:

- (a) A business headquartered within Los Angeles, Orange, Riverside, San Bernardino, or Ventura Counties. Headquartered shall mean that the business physically conducts and manages all of its operations from a location in the above-named counties; or
- (b) A business that has at least 50 full-time employees, or 25 full-time employees for specialty marine contracting firms, working in Los Angeles, Orange, Riverside, San Bernardino, or Ventura Counties.

In order for Harbor Department staff to determine the appropriate LBE preference, Consultant shall complete, sign, notarize (where applicable) and submit the attached Affidavit and Consultant Description Form. The Affidavit and Consultant Description Form will signify the LBE status of the Consultant and subconsultants.

In the event of Consultant's noncompliance during the performance of the Agreement, Consultant shall be considered in material breach of contract. In addition to any other remedy available to City under this Agreement or by operation of law, the City may withhold invoice payments to Consultant until noncompliance is corrected, and assess the costs of City's audit of books and records of Consultant and its subconsultants. In the event the Consultant falsifies or misrepresents information contained in any form or other willful noncompliance as determined by City, City may disqualify the Consultant from participation in City contracts for a period of up to five (5) years.

AFFIDAVIT OF COMPANY STATUS

"The undersigned declares under penalty of perjury pursuant to the laws of the State of California that the following information and information contained on **the attached Consultant Description Form** is true and correct and includes all material information necessary to identify and explain the operations of

Name of Firm

as well as the ownership and location thereof. Further, the undersigned agrees to provide complete and accurate information regarding ownership in the named firm, and all of its domestic and foreign affiliates, any proposed changes of the ownership and to permit the audit and examination of firm ownership documents, and the ownership documents of all of its domestic and foreign affiliates, in association with this agreement."

(1) **Small/Very Small Business Enterprise Program:** Please indicate the ownership of your company. Please check all that apply. At least one box must be checked:

SBE VSBE MBE WBE DVBE OBE

- A Small Business Enterprise (SBE) is an independently owned and operated business that is not dominant in its field and meets criteria set forth by the Small Business Administration in Title 13, Code of Federal Regulations, Part 121.
- A Very Small Business Enterprise (VSBE) is 1) a small business that has average annual gross receipts of \$5,000,000 or less within the previous three years, or (2) a small business manufacturer with 25 or fewer employees.
- A Minority Business Enterprise (MBE) is defined as a business in which a minority owns and controls at least 51% of the business. A Woman Business (WBE) is defined as a business in which a woman owns and controls at least 51% of the business. For the purpose of this project, a minority includes:
 - (1) Black (all persons having origins in any of the Black African racial groups not of Hispanic origin);
 - (2) Hispanic (all persons of Mexican, Puerto Rican, Cuban, Central or South American or other Spanish Culture or origin, regardless of race);
 - (3) Asian and Pacific Islander (all persons having origins in any of the original peoples of the Far East, Southeast Asia, The Indian Subcontinent, or the Pacific Islands); and
 - (4) American Indian or Alaskan Native (all persons having origins in any of the original peoples of North America and maintaining identifiable tribal affiliations through membership and participation or community identification).
- A Disabled Veteran Business Enterprise (DVBE) is defined as a business in which a disabled veteran owns at least 51% of the business, and the daily business operations are managed and controlled by one or more disabled veterans.
- An OBE (Other Business Enterprise) is any enterprise that is neither an SBE, VSBE, MBE, WBE, or DVBE.

(2) **Local Business Preference Program:** Please indicate the Local Business Enterprise status of your company. Only one box must be checked:

LBE Non-LBE

- A Local Business Enterprise (LBE) is: (a) a business headquartered within Los Angeles, Orange, Riverside, San Bernardino, or Ventura Counties; or (b) a business that has at least 50 full-time employees, or 25 full-time employees for specialty marine contracting firms, working in Los Angeles, Orange, Riverside, San Bernardino, or Ventura Counties. “Headquartered” shall mean that the business physically conducts and manages all of its operations from a location in the above-named counties.
- A Non-LBE is any business that does not meet the definition of a LBE.

Signature: _____

Title: _____

Printed Name: _____

Date Signed: _____

Consultant Description Form

PRIME CONSULTANT:

Contract Title: _____

Business Name: _____ RAMP ID#: _____

Award Total: \$ _____

Owner's Ethnicity: _____ Gender _____ Group: SBE VSBE MBE WBE DVBE OBE (Circle all that apply)

Local Business Enterprise: YES _____ NO _____ (Check only one)

Primary NAICS Code: _____

Address: _____

City/State/Zip: _____

County: _____

Telephone: () _____ FAX: () _____

Contact Person/Title: _____

Email Address: _____

SUBCONSULTANT:

Business Name: _____ RAMP ID#: _____

Award Total: (% or \$): _____

Services to be provided: _____

Owner's Ethnicity: _____ Gender _____ Group: SBE VSBE MBE WBE DVBE OBE (Circle all that apply)

Local Business Enterprise: YES _____ NO _____ (Check only one)

Primary NAICS Code: _____

Address: _____

City/State/Zip: _____

County: _____

Telephone: () _____ FAX: () _____

Contact Person/Title: _____

Email Address: _____

SUBCONSULTANT:

Business Name: _____ RAMP ID#: _____

Award Total: (% or \$): _____

Services to be provided: _____

Owner's Ethnicity: _____ Gender _____ Group: SBE VSBE MBE WBE DVBE OBE (Circle all that apply)

Local Business Enterprise: YES _____ NO _____ (Check only one)

Primary NAICS Code: _____

Address: _____

City/State/Zip: _____

County: _____

Telephone: () _____ FAX: () _____

Contact Person/Title: _____

Email address: _____

Consultant Description Form

SUBCONSULTANT:

Business Name: _____ RAMP ID#: _____

Award Total: (% or \$): _____

Services to be provided: _____

Owner's Ethnicity: _____ Gender _____ Group: SBE VSBE MBE WBE DVBE OBE (Circle all that apply)

Local Business Enterprise: YES _____ NO _____ (Check only one)

Primary NAICS Code: _____

Address: _____

City/State/Zip: _____

County: _____

Telephone: () _____ FAX: () _____

Contact Person/Title: _____

Email Address: _____

SUBCONSULTANT:

Business Name: _____ RAMP ID#: _____

Award Total: (% or \$): _____

Services to be provided: _____

Owner's Ethnicity: _____ Gender _____ Group: SBE VSBE MBE WBE DVBE OBE (Circle all that apply)

Local Business Enterprise: YES _____ NO _____ (Check only one)

Primary NAICS Code: _____

Address: _____

City/State/Zip: _____

County: _____

Telephone: () _____ FAX: () _____

Contact Person/Title: _____

Email Address: _____

SUBCONSULTANT:

Business Name: _____ RAMP ID#: _____

Award Total: (% or \$): _____

Services to be provided: _____

Owner's Ethnicity: _____ Gender _____ Group: SBE VSBE MBE WBE DVBE OBE (Circle all that apply)

Local Business Enterprise: YES _____ NO _____ (Check only one)

Primary NAICS Code: _____

Address: _____

City/State/Zip: _____

County: _____

Telephone: () _____ FAX: () _____

Contact Person/Title: _____

Email address: _____



EXHIBIT C PROPRIETARY SMALL BUSINESS ENTERPRISE (SBE)

ROADMAP FOR APPLICANTS

Should I apply?

If your firm is currently certified with any of the following agencies, you do NOT need to submit the SBE (Proprietary) Application:

- Federal Small Business Administration (SBA) - 8(a) Business Development Program
- State of California Department of General Services (DGS) – Small Business (SB), Micro Business (MB) and Public Works (PW)
- California Department of Transportation (CALTRANS)- Small Minority/Women Business Enterprise (SMBE/SWBE)
- L.A. County Metropolitan Transportation Authority (METRO) – Small Business Enterprise (SBE)
- US Women's Chamber of Commerce (USWCC) - Women-Owned Small Business (WOSB) & Economically Disadvantaged Women-owned Business (EDWOSB)
- National Women Business Owners Corporation (NWBOC) - Women-Owned Small Business (WOSB) & Economically Disadvantaged Women-owned Business (EDWOSB)
- Women's Business Enterprise Council WEST (WBEC - West) - Women-Owned Small Business (WOSB)
- City of Los Angeles – Local Small Business (LSB)
- Los Angeles County – Local Small Business Enterprise (LSBE)
- California Unified Certification Program (CUCP) – Disadvantaged Business Enterprise (DBE)
 - CUCP Agencies include:*
 - California Department of Transportation (CALTRANS)
 - Central Contra Costa Transit Authority (CCCTA)
 - L.A. County Metropolitan Transportation Authority (METRO)
 - San Francisco Bay Area Rapid Transit District (BART)
 - San Francisco Municipal Transportation Agency (SFMTA)
 - Santa Clara Valley Transportation Authority (VTA)
 - City of Fresno
 - City of Los Angeles
 - San Diego County Regional Airport Authority (SAN)
 - San Francisco International Airport (SFO)
 - San Mateo County Transit District (SAMTRANS)

If you are certified by one of the agencies listed above you may add SBE (Proprietary) to your RAMP profile for verification or check the Bid/Proposal documents for the Department's instruction regarding verification of certification.

If your firm is not currently certified with one of the above agencies, answer these questions:

- Is your firm an independently-owned and operated business?
- Is your firm a small business that meets the size criteria set forth by the Small Business Administration 8(a) Business Development Program or the State of California DGS Small Business Program?
- Is your firm organized as a for-profit business?

If you answered "Yes" to all of the questions above, you may be eligible to be certified as an SBE (Proprietary)

Complete the attached application and include all of the required documents listed on the checklist of SUPPORTING DOCUMENTATION at the end of this form.

Send completed application to:

CITY OF LOS ANGELES
DEPARTMENT OF PUBLIC WORKS
Bureau of Contract Administration
Office of Contract Compliance – Centralized Certification Administration
1149 S. Broadway, Ste. 300
Los Angeles, CA 90015

For Assistance:

Email bca.certifications@lacity.org or Call (213) 847-2684

Where can I find more information?

- State of California SBE program - <http://www.dgs.ca.gov/pd/Programs/OSDS/GetCertified.aspx>
- Small Business Administration 8(a) Business Development, WOSB, and EDWOSB Programs: <http://www.sba.gov>
- SBA Size Standards www.sba.gov/sites/default/files/Size_Standards_Table.pdf
- NAICS Search <https://www.census.gov/naics/?99967>
- LAWA SBE Program Rules and Regulations – http://www.lawa.org/welcome_LAWA.aspx?id=6413
- Port of Los Angeles Small Business Enterprise (SBE) and VSBE Program information- <https://www.portoflosangeles.org/business/sbp.asp>
- DWP SBE Program Information – https://www.ladwp.com/ladwp/faces/ladwp/partners/p-vendorsandbidders/p-vb-sbedvbe?_afdf.ctrl-state=bfw1rfro4_4&_afdfLoop=78220979903629



EXHIBIT C

PROPRIETARY SMALL BUSINESS ENTERPRISE (SBE)

Please answer the following:

Which Department referred you to the Office of Contract Compliance for Proprietary SBE Certification?
(You must check only one box)

- Department of Water and Power
- Harbor Department
- Los Angeles World Airports

Are you currently bidding or participating on a City Project?

- NO YES

If yes, please provide the following information:

Project Name: _____

BAVN ID#: _____

Bid/RFP Number: _____

Due Date: _____



EXHIBIT C

PROPRIETARY SMALL BUSINESS ENTERPRISE (SBE)

I. GENERAL INFORMATION			
HAS YOUR FIRM BEEN CERTIFIED BY ANOTHER CERTIFYING AGENCY? <input type="checkbox"/> YES <input type="checkbox"/> NO			
IF YES, WHICH AGENCY & CERTIFICATION (e.g. SBE, MBE, WBE, DBE, etc.):	HAS FIRM EVER BEEN DENIED CERTIFICATION? <input type="checkbox"/> YES <input type="checkbox"/> NO IF YES, WHICH AGENCY & DATE:		
LEGAL BUSINESS NAME	FICTITIOUS OR DOING BUSINESS AS (DBA) NAME(S):		
STREET ADDRESS OF PRINCIPAL OFFICE LOCATION (DO NOT USE PO BOX)	CITY	STATE	ZIP
MAILING ADDRESS (IF DIFFERENT)	CITY	STATE	ZIP
FEDERAL EMPLOYER ID NUMBER (FEIN)	DATE FIRM ESTABLISHED:	WEBPAGE ADDRESS:	
PRIMARY POINT OF CONTACT: (NAME & TITLE)	PHONE NUMBER:	FAX NUMBER:	
	OTHER PHONE NUMBER:	EMAIL ADDRESS:	
ADDRESSES OF OTHER LOCATIONS, FACILITIES, STORAGE SPACES, ETC. (ATTACH ADDITIONAL PAGES IF NECESSARY)			
DESCRIPTION (e.g. STORAGE, FIELD OFFICE, FACTORY)	CITY	STATE	ZIP
DESCRIPTION (e.g. STORAGE, FIELD OFFICE, FACTORY)	CITY	STATE	ZIP
METHOD OF ACQUISITION: <input type="checkbox"/> STARTED NEW BUSINESS <input type="checkbox"/> PURCHASED EXISTING BUSINESS <input type="checkbox"/> INHERITED BUSINESS OTHER (EXPLAIN): _____			
BUSINESS STRUCTURE: <input type="checkbox"/> SOLE PROPRIETORSHIP <input type="checkbox"/> PARTNERSHIP <input type="checkbox"/> CORPORATION <input type="checkbox"/> LLC <input type="checkbox"/> JOINT VENTURE			
TYPE OF BUSINESS: <input type="checkbox"/> CONSTRUCTION <input type="checkbox"/> MANUFACTURING <input type="checkbox"/> SERVICE/CONSULTING <input type="checkbox"/> WHOLESALER/RETAILER <input type="checkbox"/> DISTRIBUTOR/BROKER <input type="checkbox"/> CONCESSION <input type="checkbox"/> TRUCKER <input type="checkbox"/> OTHER _____			
IF TYPE OF BUSINESS IS CONSTRUCTION, PROVIDE:			
CONTRACTOR'S LICENSE NUMBER:	LICENSE CLASSIFICATION CODE(S) :		
ENTER FIRM'S AVERAGE NUMBER OF EMPLOYEES FOR THE LAST FOUR QUARTERS INCLUDING ALL EMPLOYEES THAT ARE IN CALIFORNIA, OUT OF STATE, AND/OR OUT OF THE COUNTRY. (IF IN BUSINESS LESS THAN A YEAR, AVERAGE THE NUMBER OF EMPLOYEES OVER THE NUMBER OF QUARTERS THAT YOU HAVE BEEN IN BUSINESS)			NUMBER OF EMPLOYEES:
NUMBER OF: OWNERS _____ OFFICERS _____ DIRECTORS _____			
HAS FIRM EVER EXISTED UNDER DIFFERENT OWNERSHIP? <input type="checkbox"/> YES <input type="checkbox"/> NO			
IF YES, PROVIDE PREVIOUS OWNERSHIP, BUSINESS STRUCTURE, DATE THE CHANGE OCCURRED, AND BRIEF EXPLANATION OF CHANGE:			



EXHIBIT C PROPRIETARY SMALL BUSINESS ENTERPRISE (SBE)

II. OWNERSHIP (ATTACH ADDITIONAL PAGES IF NECESSARY)			
NAME OF INDIVIDUAL OWNER(S) SHAREHOLDER(S) AND/OR CORPORATE OFFICERS	TITLE	% OWNERSHIP	HOME ADDRESS (STREET, CITY, STATE, ZIP)

III. AFFILIATE BUSINESS RELATIONSHIP(S) - DO NOT LEAVE BLANK OR ENTER N/A		
DURING THE PREVIOUS THREE (3) TAX YEARS DID ANY OWNER/OFFICER:		
	YES	NO
1. HAVE OWNERSHIP INTEREST IN ANOTHER BUSINESS?	<input type="checkbox"/>	<input type="checkbox"/>
2. SHARE OR HAVE COMMON MANAGEMENT WITH ANOTHER BUSINESS?	<input type="checkbox"/>	<input type="checkbox"/>
3. SHARE OR HAVE COMMON OWNERS WITH ANOTHER BUSINESS?	<input type="checkbox"/>	<input type="checkbox"/>
4. HAVE A FAMILY MEMBER(S) ENGAGED IN A SIMILAR BUSINESS ACTIVITY?	<input type="checkbox"/>	<input type="checkbox"/>
5. HAVE A FINANCIAL RELATIONSHIP WITH ANOTHER BUSINESS CONSISTING OF A LOAN AND/OR ASSISTANCE BOND, SECURITY, OR CREDIT REQUIREMENTS?	<input type="checkbox"/>	<input type="checkbox"/>
6. HAVE A LONG-TERM OR PERMANENT CONTRACTUAL RELATIONSHIP WITH ANOTHER BUSINESS?	<input type="checkbox"/>	<input type="checkbox"/>
7. SHARE FACILITIES, EQUIPMENT, OR SYSTEMS WITH ANOTHER BUSINESS?	<input type="checkbox"/>	<input type="checkbox"/>
8. SHARE EMPLOYEES WITH ANOTHER BUSINESS?	<input type="checkbox"/>	<input type="checkbox"/>

IF YOU ANSWERED YES TO ANY OF THE ABOVE, PROVIDE THE FOLLOWING INFORMATION FOR EACH BUSINESS THAT APPLIES TO EACH "YES" RESPONSE (ATTACH ADDITIONAL PAGES IF NECESSARY)		
1) OWNER/OFFICER NAME	2) OWNER/OFFICER NAME	3) OWNER/OFFICER NAME
BUSINESS NAME	BUSINESS NAME	BUSINESS NAME
BUSINESS ADDRESS	BUSINESS ADDRESS	BUSINESS ADDRESS
NATURE OF BUSINESS	NATURE OF BUSINESS	NATURE OF BUSINESS
NATURE OF RELATIONSHIP W/ APPLICANT FIRM	NATURE OF RELATIONSHIP W/ APPLICANT FIRM	NATURE OF RELATIONSHIP W/ APPLICANT FIRM

IV. BUSINESS CLASSIFICATION	
PROVIDE A DESCRIPTION OF YOUR BUSINESS AND/OR INDIVIDUAL KEYWORDS WHICH BEST DESCRIBE YOUR BUSINESS SERVICES: USE THE NORTH AMERICAN INDUSTRY CLASSIFICATION SYSTEM (NAICS) TO IDENTIFY THE FIRM'S AREA(S) OF SPECIALTY. THE PRIMARY NAICS REPRESENTS THE FIRM'S LARGEST SOURCE OF REVENUE FOR THE MOST RECENTLY COMPLETED FISCAL YEAR. ENTER UP TO 5 CODES. FOR A FULL LIST OF NAICS CODES AND ASSISTANCE IN LOCATING APPROPRIATE CODES PLEASE VISIT: HTTP://WWW.NAICS.COM/SEARCH.HTM	
6 DIGIT NAICS CODE & DESCRIPTION:	% OF THE FIRM'S REVENUES EARNED IN THIS NAICS DURING PAST 12 MONTHS:
1)	
2)	
3)	
4)	
5)	



EXHIBIT C PROPRIETARY SMALL BUSINESS ENTERPRISE (SBE)

PENALTY OF PERJURY DECLARATION

The undersigned states:

I certify under penalty of perjury under the laws of the City of Los Angeles and the State of California that all information submitted in the Small Business Enterprise application, and any additional information to determine eligibility is true and correct.

Authorized Signature

Title

Print Name

Date

SUPPORTING DOCUMENTATION CHECKLIST **SUBMIT REQUIRED DOCUMENTATION FOR ALL CATEGORIES BELOW THAT APPLY TO YOUR BUSINESS.**

PLEASE DO NOT BIND YOUR SUBMITTAL

ALL APPLICANTS

- Most recently entire filed Federal Individual Income Tax Return (Form 1040) for **each owner** including all schedules and statements.
- Entire filed Federal Income Tax Return (Form 1040, 1220, 1120S or 1065) for the applicant business **and** each affiliate business for the most recent three (3) years or for the years the firm or its affiliate(s) were in business.
- If the firm's business classification identified by the selected NAICS codes requires a professional license or permit in order to operate, include a copy of the current license or permit (e.g. Architect, Engineer, Contractor, Broker/Agent, Lawyer, Security, etc.)
- If the size standard for the selected NAICS codes is number of employees- provide the Quarterly Contribution returns and report of wages (Form DE 9C) for the applicant business and each affiliate business for the four (4) most recent completed quarters. Submit a copy of out of state and/or out of country equivalent to form DE 9C, if applicable.

SOLE PROPRIETORSHIP

- Fictitious Business Name Statement

PARTNERSHIP

- Partnership Agreement and Amendments

CORPORATION

- Articles of Incorporation (*signed by the state official with approval date*)
- Corporate Meeting minutes for the past two (2) years listing current elected corporate officers and directors; or statement of information as filed with CA Secretary of State

LLC

- Articles of Organization, as filed with State
- LLC Statement of Information
- Operating Agreement and Amendments

JOINT VENTURE

- Joint Venture Agreement and Amendments

TRUCKING COMPANY

- Title(s) and registration certificate(s) for each truck owned and/or operated by your business
- Current Motor Carrier Permit

Exhibit D - Business Tax Registration Certificate (BTRC) Number

The City of Los Angeles, Office of Finance requires all firms that engage in any business activity within the City of Los Angeles to pay City business taxes. Each firm or individual (other than a municipal employee) is required to obtain the necessary Business Tax Registration Certification (BTRC) and pay business tax. (Los Angeles Municipal code Section 21.09 et seq.)

All firms and individuals that do business with the City of Los Angeles will be required to provide a BTRC number or an exemption number as proof of compliance with Los Angeles City business tax requirements in order to receive payment for goods or services. Beginning October 14, 1987, payments for goods or services will be withheld unless proof of tax compliance is provided to the City.

The Tax and Permit Division of Los Angeles Office of Finance, has the sole authority to determine whether a firm is covered by business tax requirements. Those firms not required to pay will be given an exemption number.

If you do NOT have a BTRC number contact the Tax and Permit Division at the office listed below, or log on to <http://finance.lacity.org/>, to download the business tax registration application.

MAIN OFFICE

LA City Hall

201 N. Main Street, Rm. 101

(844) 663-4411

Exhibit E- Equal Benefits Ordinance

Sec. 10.8.2.1. Equal Benefits Ordinance.

Discrimination in the provision of employee benefits between employees with domestic partners and employees with spouses results in unequal pay for equal work. Los Angeles law prohibits entities doing business with the City from discriminating in employment practices based on marital status and/or sexual orientation. The City's departments and contracting agents are required to place in all City contracts a provision that the company choosing to do business with the City agrees to comply with the City's nondiscrimination laws.

It is the City's intent, through the contracting practices outlined in this Ordinance, to assure that those companies wanting to do business with the City will equalize the total compensation between similarly situated employees with spouses and with domestic partners. The provisions of this Ordinance are designed to ensure that the City's contractors will maintain a competitive advantage in recruiting and retaining capable employees, thereby improving the quality of the goods and services the City and its people receive, and ensuring protection of the City's property.

(c) Equal Benefits Requirements.

(1) No Awarding Authority of the City shall execute or amend any Contract with any Contractor that discriminates in the provision of Benefits between employees with spouses and employees with Domestic Partners, between spouses of employees and Domestic Partners of employees, and between dependents and family members of spouses and dependents and family members of Domestic Partners.

(2) A Contractor must permit access to, and upon request, must provide certified copies of all of its records pertaining to its Benefits policies and its employment policies and practices to the DAA, for the purpose of investigation or to ascertain compliance with the Equal Benefits Ordinance.

(3) A Contractor must post a copy of the following statement in conspicuous places at its place of business available to employees and applicants for employment: "During the performance of a Contract with the City of Los Angeles, the Contractor will provide equal benefits to its employees with spouses and its employees with domestic partners." The posted statement must also include a City contact telephone number which will be provided each Contractor when the Contract is executed.

(4) A Contractor must not set up or use its contracting entity for the purpose of evading the requirements imposed by the Equal Benefits Ordinance.

(d) Other Options for Compliance. Provided that the Contractor does not discriminate in the provision of Benefits, a Contractor may also comply with the Equal Benefits Ordinance in the following ways:

(1) A Contractor may provide an employee with the Cash Equivalent only if the DAA determines that either:

a. The Contractor has made a reasonable, yet unsuccessful effort to provide Equal Benefits; or

b. Under the circumstances, it would be unreasonable to require the Contractor to provide Benefits to the Domestic Partner (or spouse, if applicable).

(2) Allow each employee to designate a legally domiciled member of the employee's household as being eligible for spousal equivalent Benefits.

(3) Provide Benefits neither to employees' spouses nor to employees' Domestic Partners.

(e) Applicability.

(1) Unless otherwise exempt, a Contractor is subject to and shall comply with all applicable provisions of the Equal Benefits Ordinance.

(2) The requirements of the Equal Benefits Ordinance shall apply to a Contractor's operations as follows:

a. A Contractor's operations located within the City limits, regardless of whether there are employees at those locations performing work on the Contract.

b. A Contractor's operations on real property located outside of the City limits if the property is owned by the City or the City has a right to occupy the property, and if the Contractor's presence at or on that property is connected to a Contract with the City.

c. The Contractor's employees located elsewhere in the United States but outside of the City limits if those employees are performing work on the City Contract.

(3) The requirements of the Equal Benefits Ordinance do not apply to collective bargaining agreements ("CBA") in effect prior to January 1, 2000. The Contractor must agree to propose to its union that the requirements of the Equal Benefits Ordinance be incorporated into its CBA upon amendment, extension, or other modification of a CBA occurring after January 1, 2000.

(f) Mandatory Contract Provisions Pertaining to Equal Benefits. Unless otherwise exempted, every Contract shall contain language that obligates the Contractor to comply with the applicable provisions of the Equal Benefits Ordinance. The language shall include provisions for the following:

(1) During the performance of the Contract, the Contractor certifies and represents that the Contractor will comply with the Equal Benefits Ordinance.

(2) The failure of the Contractor to comply with the Equal Benefits Ordinance will be deemed to be a material breach of the Contract by the Awarding Authority.

(3) If the Contractor fails to comply with the Equal Benefits Ordinance the Awarding Authority may cancel, terminate or suspend the Contract, in whole or in part, and all monies due or to become due under the Contract may be retained by the City. The City may also pursue any and all other remedies at law or in equity for any breach.

(4) Failure to comply with the Equal Benefits Ordinance may be used as evidence against the Contractor in actions taken pursuant to the provisions of Los Angeles Administrative Code Section 10.40, et seq., Contractor Responsibility Ordinance.

(5) If the DAA determines that a Contractor has set up or used its Contracting entity for the purpose of evading the intent of the Equal Benefits Ordinance, the Awarding Authority may terminate the Contract on behalf of the City. Violation of this provision may be used as evidence against the Contractor in actions taken pursuant to the provisions of Los Angeles Administrative Code Section 10.40, et seq., Contractor Responsibility Ordinance.

EXHIBIT F

RFP SELECTION EVALUATION FORM

PROJECT: ON – CALL UNDERWATER HARD HAT DIVING SERVICES

SCORING GUIDELINES:

Rater's Score: (Range 0-5) - 0=not included/non responsive; 1= Serious Deficiencies; 2=Marginal Abilities; 3=Adequate, 4=Well Qualified; 5=Exceptionally Qualified.

Scores must be **whole numbers only** (for example, "3.5" is not acceptable).

Weighing Factor: A range of 1 through 6, with 1 being of relative lower importance and 6 being relative highest importance. Each number (1 through 6) may be used more than once; however, in establishing weights, the total of all the weighing factors (A –E) must equal 20. Example: 3+2+6+4+5=20 or 3+3+3+6+5=20

Weighted Score= Rater's Score multiplied by (x) Weighing Factor. Totals should be calculated for each criterion.

Total score = Sum of all weighted scores.

Firm Name	Evaluated by	Date

CRITERIA TO BE RATED		RATER'S SCORE	WEIGHING FACTOR	WEIGHTED SCORE
A. Firm Qualifications, Experience and References	How long has the company been in business? Has the company done similar work? Level of expertise in subject matter areas?		5	
B. Organization, Personnel and Staffing	Qualification and experience of proposed personnel for requested services? Locally based firm or team?		5	
C. Approach, Work Plan, Management, Safety Program, and Equipment	Quality of proposed work plan to meet project requirements? Quality of project management? Quality of Safety Program and Equipment?		4	
D. Rates, Fees and Budget Control	Competitive rates and fees proposed? Are proposed budget management, fees and staff hours proposed and clearly defined?		4	
E. Clarity and Comprehensiveness of the Proposal	Is the proposal clear, comprehensive, and understandable?		2	
	Maximum points possible=100		A+B+C+D+E=20	Total Points=

This form must be submitted with your bid or proposal to the City department that is awarding the contract noted below. If you have questions about this form, please contact the Ethics Commission at (213) 978-1960.

Original Filing Amendment: Date of Signed Original _____ Date of Last Amendment _____.

Reference Number (Bid, Contract, or BAVN)	Awarding Authority (Department awarding the contract)	
Bidder Name		
Address		
Email Address	Phone Number	

Certification

I certify the following on my own behalf or on behalf of the entity named above, which I am authorized to represent:

A. I am applying for one of the following types of contracts with the City of Los Angeles:

1. A goods or services contract with a value of more than \$25,000 and a term of at least three months;
2. A construction contract with any value and duration;
3. A financial assistance contract, as defined in Los Angeles Administrative Code § 10.40.1(h), with a value of at least \$100,000 and a term of any duration; or
4. A public lease or license, as defined in Los Angeles Administrative Code § 10.40.1(i), with any value and duration.

B. I acknowledge and agree to comply with the disclosure requirements and prohibitions established in the Los Angeles Municipal Lobbying Ordinance if I qualify as a lobbying entity under Los Angeles Municipal Code § 48.02.

I certify under penalty of perjury under the laws of the City of Los Angeles and the state of California that the information in this form is true and complete.

Name

Signature

Title

Date

Los Angeles Administrative Code § 10.40.1

- (h) **"City Financial Assistance Recipient"** means any person who receives from the City discrete financial assistance in the amount of One Hundred Thousand Dollars (\$100,000.00) or more for economic development or job growth expressly articulated and identified by the City, as contrasted with generalized financial assistance such as through tax legislation.

Categories of such assistance shall include, but are not limited to, bond financing, planning assistance, tax increment financing exclusively by the City, and tax credits, and shall not include assistance provided by the Community Development Bank. City staff assistance shall not be regarded as financial assistance for purposes of this article. A loan shall not be regarded as financial assistance. The forgiveness of a loan shall be regarded as financial assistance. A loan shall be regarded as financial assistance to the extent of any differential between the amount of the loan and the present value of the payments thereunder, discounted over the life of the loan by the applicable federal rate as used in 26 U.S.C. Sections 1274(d), 7872(f). A recipient shall not be deemed to include lessees and sublessees.

Los Angeles Administrative Code § 10.37.1

- (l) **"Public lease or license"**.

- (a) Except as provided in (l)(b), "Public lease or license" means a lease or license of City property on which services are rendered by employees of the public lessee or licensee or sublessee or sublicensee, or of a contractor or subcontractor, but only where any of the following applies:
- (1) The services are rendered on premises at least a portion of which is visited by substantial numbers of the public on a frequent basis (including, but not limited to, airport passenger terminals, parking lots, golf courses, recreational facilities); or
 - (2) Any of the services could feasibly be performed by City employees if the awarding authority had the requisite financial and staffing resources; or
 - (3) The DAA has determined in writing that coverage would further the proprietary interests of the City.
- (b) A public lessee or licensee will be exempt from the requirements of this article subject to the following limitations:
- (1) The lessee or licensee has annual gross revenues of less than the annual gross revenue threshold, three hundred fifty thousand dollars (\$350,000), from business conducted on City property;
 - (2) The lessee or licensee employs no more than seven (7) people total in the company on and off City property;
 - (3) To qualify for this exemption, the lessee or licensee must provide proof of its gross revenues and number of people it employs in the company's entire workforce to the awarding authority as required by regulation;
 - (4) Whether annual gross revenues are less than three hundred fifty thousand dollars (\$350,000) shall be determined based on the gross revenues for the last tax year prior to application or such other period as may be established by regulation;
 - (5) The annual gross revenue threshold shall be adjusted annually at the same rate and at the same time as the living wage is adjusted under section 10.37.2 (a);
 - (6) A lessee or licensee shall be deemed to employ no more than seven (7) people if the company's entire workforce worked an average of no more than one thousand two-hundred fourteen (1,214) hours per month for at least three-fourths (3/4) of the time period that the revenue limitation is measured;
 - (7) Public leases and licenses shall be deemed to include public subleases and sublicenses;
 - (8) If a public lease or license has a term of more than two (2) years, the exemption granted pursuant to this section shall expire after two (2) years but shall be renewable in two-year increments upon meeting the requirements therefor at the time of the renewal application or such period established by regulation.

Prohibited Contributors (Bidders)

This form must be completed in its entirety and submitted with your bid or proposal to the City department that is awarding the contract. Failure to submit a completed form may affect your bid or proposal. If you have questions about this form, please contact the Ethics Commission at (213) 978-1960.

Original Filing **Amendment:** Date of Signed Original _____ Date of Last Amendment _____

Reference Number (Bid, Contract, or BAVN): _____ Date Bid Submitted: _____

Contract Description (Title of the RFP or City contract solicitation and description of the services to be provided):

Awarding Authority (Department awarding the contract): _____

Bidder Name: _____

Bidder Address: _____

Bidder Email Address: _____ Bidder Phone Number: _____

Schedule Summary

Please complete all three of the following:

- | | | |
|---|--|---|
| <p>1. SCHEDULE A – Bidder’s Principals <i>(check one)</i>
The bidder has one or more PRINCIPALS, as defined in LAMC § 49.7.35(A)(6).
At least one principal is required for entities. <i>(If you check “Yes”, Schedule A is required.)</i></p> | <p>Yes
<input type="checkbox"/></p> | <p>No
<input type="checkbox"/></p> |
| <p>2. SCHEDULE B – Subcontractors and Their Principals <i>(check one)</i>
The bidder has one or more SUBCONTRACTORS on this bid or proposal with
subcontracts worth \$100,000 or more. <i>(If you check “Yes”, Schedule B is required.)</i></p> | <p>Yes
<input type="checkbox"/></p> | <p>No
<input type="checkbox"/></p> |
| <p>3. TOTAL NUMBER OF PAGES SUBMITTED (including this cover page): _____</p> | | |

Certification

I certify the following under penalty of perjury under the laws of the City of Los Angeles and the state of California:
A) I understand, will comply with, and have notified my principals and subcontractors of the requirements and restrictions in Los Angeles City Charter § 470(c)(12) and any related ordinances; B) I understand that I must amend this form within ten business days if any information changes; C) I am the bidder named above or I am authorized to represent the bidder named above, and my name appears below; and D) The information provided in this form is true and complete to the best of my knowledge and belief.

Name

Signature

Title

Date

Schedule A - Bidder's Principals

Please identify the names and titles of all the bidder's principals (attach additional sheets if necessary). Principals include a bidder's board chair, president, chief executive officer, chief operating officer, and individuals who serve in the functional equivalent of one or more of those positions. Principals also include individuals who hold an ownership interest in the bidder of at least 20 percent and employees of the bidder who are authorized by the bid or proposal to represent the bidder before the City.

Name: _____ Title: _____ Address: _____
Name: _____ Title: _____ Address: _____
Name: _____ Title: _____ Address: _____
Name: _____ Title: _____ Address: _____
Name: _____ Title: _____ Address: _____
Name: _____ Title: _____ Address: _____
Name: _____ Title: _____ Address: _____
Name: _____ Title: _____ Address: _____
Name: _____ Title: _____ Address: _____
Name: _____ Title: _____ Address: _____

Check this box if additional Schedule A pages are attached.

Schedule B - Subcontractors and Their Principals

Please identify all subcontractors whose subcontracts are worth \$100,000 or more. Separate Schedule B pages are required for each subcontractor who meets the threshold.

Subcontractor's Name
Subcontractor's Address

Please check one of the following options:

This subcontractor has one or more principals. Yes* No

** Each principal's name and title must be identified below. Attach additional sheets if necessary. Principals include a subcontractor's board chair, president, chief executive officer, chief operating officer, and individuals who serve in the functional equivalent of one or more of those positions. Principals also include individuals who hold an ownership interest in the subcontractor of at least 20 percent and employees of the subcontractor who are authorized by the bid or proposal to represent the subcontractor before the City.*

Name: _____ Title: _____
Address: _____

Name: _____ Title: _____
Address: _____

Name: _____ Title: _____
Address: _____

Name: _____ Title: _____
Address: _____

Name: _____ Title: _____
Address: _____

Name: _____ Title: _____
Address: _____

Check this box if additional Schedule B pages are attached.

EXHIBIT H

IRAN CONTRACTING ACT OF 2010 COMPLIANCE AFFIDAVIT

(California Public Contract Code Sections 2200-2208)

The California Legislature adopted the Iran Contracting Act of 2010 to respond to policies of Iran in a uniform fashion (PCC § 2201(q)). The Iran Contracting Act prohibits bidders engaged in investment activities in Iran from bidding on, submitting proposals for, or entering into or renewing contracts with public entities for goods and services of one million dollars (\$1,000,000) or more (PCC § 2203(a)). A bidder who “engages in investment activities in Iran” is defined as either:

1. A bidder providing goods or services of twenty million dollars (\$20,000,000) or more in the energy sector of Iran, including provision of oil or liquefied natural gas tankers, or products used to construct or maintain pipelines used to transport oil or liquefied natural gas, for the energy sector of Iran; **or**
2. A bidder that is a financial institution (as that term is defined in 50 U.S.C. § 1701) that extends twenty million dollars (\$20,000,000) or more in credit to another person, for 45 days or more, if that person will use the credit to provide goods or services in the energy sector in Iran and is identified on a list created by the California Department of General Services (DGS) pursuant to PCC § 2203(b) as a person engaging in the investment activities in Iran.

The bidder shall certify that at the time of submitting a bid for new contract or renewal of an existing contract, the bidder is **not** identified on the DGS list of ineligible businesses or persons and that the bidder is **not** engaged in investment activities in Iran in violation of the Iran Contracting Act of 2010.

California law establishes penalties for providing false certifications, including civil penalties equal to the greater of \$250,000 or twice the amount of the contract for which the false certification was made; contract termination; and three-year ineligibility to bid on contracts (PCC § 2205).

To comply with the Iran Contracting Act of 2010, the bidder shall provide its vendor or financial institution name, and City Business Tax Registration Certificate (BRTC) if available, in completing **ONE** of the options shown below.

OPTION #1: CERTIFICATION

I, the official named below, certify that I am duly authorized to execute this certification on behalf of the bidder or financial institution identified below, and that the bidder or financial institution identified below is **not** on the current DGS list of persons engaged in investment activities in Iran and is **not** a financial institution extending twenty million dollars (\$20,000,000) or more in credit to another person or vendor, for 45 days or more, if that other person or vendor will use the credit to provide goods or services in the energy sector in Iran and is identified on the current DSG list of persons engaged in investment activities in Iran.

<i>Vendor Name/Financial Institution (printed)</i>		<i>BRTC (or n/a)</i>
<i>By (Authorized Signature)</i>		
<i>Print Name and Title of Person Signing</i>		
<i>Date Executed</i>	<i>City Approval (Signature)</i>	<i>(Print Name)</i>

OPTION #2: EXEMPTION

Pursuant to PCC § 2203(c) and (d), a public entity may permit a bidder or financial institution engaged in investment activities in Iran, on a case-by-case basis, to be eligible for, or to bid on, submit a proposal for, or enter into, or renew, a contract for goods and services. If the bidder or financial institution identified below has obtained an exemption from the certification requirement under the Iran Contracting Act of 2010, the bidder or financial institution shall complete and sign below and attach documentation demonstrating the exemption approval.

<i>Vendor Name/Financial Institution (printed)</i>		<i>BRTC (or n/a)</i>
<i>By (Authorized Signature)</i>		
<i>Print Name and Title of Person Signing</i>		
<i>Date Executed</i>	<i>City Approval (Signature)</i>	<i>(Print Name)</i>