

Appendix D1
Existing Traffic Counts

EXISTING TRAFFIC COUNTS

ÓÙ Þ V Æ Ö Ö Ü Á Ü W Ö S Ù

Ö Á Á æ ^ K Ö Á Ü | * í æ Á Ö Á • d æ æ æ f G Ú F á U S Ó æ S Ó Ö S Ù Ö Ú Ö Ö Ö] á

Ù æ ö Á æ ^ K F í e e e Á Ú

Û æ Á Ö | á ^ K e e e e e e e f

Ö { { ^ } ö f K Ö æ Á Á Á } * Á Ö æ @

Ö { { ^ } ö K Þ Ö Á Ö æ Á á á Á Ü ^ c

Ö { { ^ } ö K Ö Ö Y Á Ü } | ç Á á á Ö | ^ ç á á Á Ü æ]

Ö { { ^ } ö K Y Á æ @ í Á Ü } }

Ù æ ö Á æ ^	Ö Á æ Á á á Á Ü ^ c Û ^ ç á á Á Ü æ]				Û Á ^ ç Á á á Ö ^ ç á á Á Ü æ] Y Á • ç á ^ } á				Ö Á æ Á á á Á Ü ^ c Þ í ç á ^ } á				Þ Ö Y Á Ö Ü Ü U Ö Ö Þ Ö æ ç á ^ } á			
	S ^ c	V @ ^	Ü á @	Ü Á •	S ^ c	V @ ^	Ü á @	Ü Á •	S ^ c	V @ ^	Ü á @	Ü Á •	S ^ c	V @ ^	Ü á @	Ü Á •
€ F í e e Á Ú	H	Fí	€	€	G	€	í	€	€	J	í	€	€	€	€	€
€ F K í Á Ú	G	Fì	€	€	G	€	ì	€	€	I	î	€	€	€	€	€
€ F K í Á Ú	I	Fì	€	€	G	€	ì	€	€	Fí	î	€	€	€	€	€
€ F K í Á Ú	H	Fí	€	€	H	€	î	€	€	Fí	G	€	€	€	€	€
€ G í e e Á Ú	H	FJ	€	€	H	€	í	€	€	FH	I	€	€	€	€	€
€ G F í Á Ú	I	G€	€	€	F	€	FF	€	€	Fí	G	€	€	€	€	€
€ G K í Á Ú	í	Gí	€	€	G	€	î	€	€	Fí	í	€	€	€	€	€
€ G K í Á Ú	ì	GF	€	€	í	€	J	€	€	F€	G	€	€	€	€	€

ΟΡΘΟΓΡΑΦΙΚΟ ΣΥΣΤΗΜΑ

ΟΡΘΟΓΡΑΦΙΚΟ ΣΥΣΤΗΜΑ

ΟΡΘΟΓΡΑΦΙΚΟ ΣΥΣΤΗΜΑ

ΟΡΘΟΓΡΑΦΙΚΟ ΣΥΣΤΗΜΑ

ΟΡΘΟΓΡΑΦΙΚΟ ΣΥΣΤΗΜΑ

ΟΡΘΟΓΡΑΦΙΚΟ ΣΥΣΤΗΜΑ

ΟΡΘΟΓΡΑΦΙΚΟ ΣΥΣΤΗΜΑ

ΟΡΘΟΓΡΑΦΙΚΟ ΣΥΣΤΗΜΑ

ΟΡΘΟΓΡΑΦΙΚΟ ΣΥΣΤΗΜΑ

ΟΡΘΟΓΡΑΦΙΚΟ ΣΥΣΤΗΜΑ	ΟΡΘΟΓΡΑΦΙΚΟ ΣΥΣΤΗΜΑ				ΟΡΘΟΓΡΑΦΙΚΟ ΣΥΣΤΗΜΑ				ΟΡΘΟΓΡΑΦΙΚΟ ΣΥΣΤΗΜΑ				ΟΡΘΟΓΡΑΦΙΚΟ ΣΥΣΤΗΜΑ			
	Σ^c	V@	Uā@	U^a•	Σ^c	V@	Uā@	U^a•	Σ^c	V@	Uā@	U^a•	Σ^c	V@	Uā@	U^a•
ΕΡΕΥΝΑ	€	€	€	€	€	€	€	€	€	€	G	€	€	€	€	€
ΕΡΕΥΝΑ	€	G	€	€	€	€	€	G	F	€	i	€	€	€	€	€
ΕΡΕΥΝΑ	€	€	€	€	€	€	G	F	€	€	G	F	€	€	€	€
ΕΡΕΥΝΑ	F	F	€	€	€	€	G	G	€	€	H	€	€	€	€	€
ΕΡΕΥΝΑ	€	€	€	€	€	€	H	€	€	€	I	F	€	€	€	€
ΕΡΕΥΝΑ	€	G	€	€	€	€	H	F	€	€	G	F	€	€	€	€
ΕΡΕΥΝΑ	€	G	€	€	€	€	G	G	€	€	F	F	€	€	€	€
ΕΡΕΥΝΑ	€	F	€	€	€	€	G	G	€	€	€	G	€	€	€	€

ÚÇÈÚÒΠÓΘÛÁΚÒΠΩΣÒÙ

ÚÇÈÚÒΠÓΘÛÁΚÒΠΩΣÒÙ

ÚÇÈÚÒΠÓΘÛÁΚÒΠΩΣÒÙ

ÚÇÈÚÒΠÓΘÛÁΚÒΠΩΣÒÙ

ÚÇÈÚÒΠÓΘÛÁΚÒΠΩΣÒÙ

ÚÇÈÚÒΠÓΘÛÁΚÒΠΩΣÒÙ

ÚÇÈÚÒΠÓΘÛÁΚÒΠΩΣÒÙ

ÚÇÈÚÒΠÓΘÛÁΚÒΠΩΣÒÙ

ÚÇÈÚÒΠÓΘÛÁΚÒΠΩΣÒÙ

ÚÇÈÚÒΠÓΘÛÁΚÒΠΩΣÒÙ	ÚÇÈÚÒΠÓΘÛÁΚÒΠΩΣÒÙ				ÚÇÈÚÒΠÓΘÛÁΚÒΠΩΣÒÙ				ÚÇÈÚÒΠÓΘÛÁΚÒΠΩΣÒÙ				ÚÇÈÚÒΠÓΘÛÁΚÒΠΩΣÒÙ				
	ÚÇÈÚÒΠÓΘÛÁΚÒΠΩΣÒÙ	ÚÇÈÚÒΠÓΘÛÁΚÒΠΩΣÒÙ	ÚÇÈÚÒΠÓΘÛÁΚÒΠΩΣÒÙ	ÚÇÈÚÒΠÓΘÛÁΚÒΠΩΣÒÙ	ÚÇÈÚÒΠÓΘÛÁΚÒΠΩΣÒÙ	ÚÇÈÚÒΠÓΘÛÁΚÒΠΩΣÒÙ	ÚÇÈÚÒΠÓΘÛÁΚÒΠΩΣÒÙ	ÚÇÈÚÒΠÓΘÛÁΚÒΠΩΣÒÙ	ÚÇÈÚÒΠÓΘÛÁΚÒΠΩΣÒÙ	ÚÇÈÚÒΠÓΘÛÁΚÒΠΩΣÒÙ	ÚÇÈÚÒΠÓΘÛÁΚÒΠΩΣÒÙ	ÚÇÈÚÒΠÓΘÛÁΚÒΠΩΣÒÙ	ÚÇÈÚÒΠÓΘÛÁΚÒΠΩΣÒÙ	ÚÇÈÚÒΠÓΘÛÁΚÒΠΩΣÒÙ	ÚÇÈÚÒΠÓΘÛÁΚÒΠΩΣÒÙ	ÚÇÈÚÒΠÓΘÛÁΚÒΠΩΣÒÙ	ÚÇÈÚÒΠÓΘÛÁΚÒΠΩΣÒÙ
€ ΚΕΑΥΤ	HF	FHE	€	€	í	€	íí	€	€	€	FEG	í	€	€	€	€	€
€ ΚΕΙ ΑΥΤ	Hí	Fí€	€	€	î	€	îG	€	€	€	FHí	G	€	€	€	€	€
€ ΚΕΑΥΤ	Hí	FJG	€	€	FH	€	í€	F	€	€	FíH	í	€	€	€	€	€
€ ΚÍ ΑΥΤ	íG	FíJ	€	€	ì	€	íí	€	€	€	Fíí	F€	€	€	€	€	€
€ ΚΕΑΥΤ	íí	FíG	€	€	î	€	íG	F	€	€	Fíí	í	€	€	€	€	€
€ ΚΕÍ ΑΥΤ	íí	FíH	€	€	ì	€	íH	€	€	€	FíG	ì	€	€	€	€	€
€ ΚΕΑΥΤ	G	F€í	€	€	H	€	íì	F	€	€	FíH	ì	€	€	€	€	€
€ ΚÍ ΑΥΤ	G	Jí	€	€	F	€	íí	€	€	€	FíG	í	€	€	€	€	€

UVPÖÜÄÜWÖSÜ

ÖÄ^Ääç ^KÖHÜ| *!äç ÄQ^*äç ääçGÜFajU SÖäSÖÖCSÜÖÜÜT ä]ä

ÜcäcÖä^KGÖB BEFG

ÜcäcÖä^ä ^KI KEEÄÜT

Üä^ÄÜ| ä^KEEEEEEF

Ö|{ { ^} öfKÖä Ä -Ä| } * Ä^äç@

Ö|{ { ^} öfKÖBÜHÜQäç ^äaÄÜd^^c

Ö|{ { ^} öfKÖBY HÜ^| ^ç^äaÄÜ| ^çäaÄÜäç]

Ö|{ { ^} öfKY ^äç@:HÜ}}^

ÜcäcÖä^ ^	Öäç ^äaÄÜd^^c Ü ^c@ ^} ä				Ü^ ^ç^äaÄÜ ^çäaÄÜäç] Y ^*c@ ^} ä				Öäç ^äaÄÜd^^c B ^c@ ^} ä				BÖY ÄÜJÜÜUÖÖP Öäçc@ ^} ä			
	S^c	V@^	Üä @	Ü^ä*	S^c	V@^	Üä @	Ü^ä*	S^c	V@^	Üä @	Ü^ä*	S^c	V@^	Üä @	Ü^ä*
€ KEEÄÜT	I	FG	€	€	F	€	FG	€	€	F	I	€	€	€	€	€
€ KÍ ÄÜT	F	F€	€	€	€	€	H	€	€	FG	H	€	€	€	€	€
€ KÍ ÄÜT	I	G	€	€	F	€	I	€	€	FÍ	G	€	€	€	€	€
€ KÍ ÄÜT	I	FÍ	€	€	F	€	J	€	€	FÍ	G	€	€	€	€	€
€ KEEÄÜT	G	QF	€	€	€	€	G	€	€	G	F	€	€	€	€	€
€ KÍ ÄÜT	F	FI	€	€	€	€	I	€	€	FG	€	€	€	€	€	€
€ KEEÄÜT	I	F€	€	€	F	€	I	€	€	FF	F	€	€	€	€	€
€ KÍ ÄÜT	I	FÍ	€	€	F	€	G	€	€	FI	€	€	€	€	€	€

ÓΥΝΟΜΑΤΑ ΠΡΟΣΩΠΩΝ

ΟΥΝΟΜΑΤΑ ΠΡΟΣΩΠΩΝ
 ΟΥΝΟΜΑΤΑ ΠΡΟΣΩΠΩΝ
 ΟΥΝΟΜΑΤΑ ΠΡΟΣΩΠΩΝ
 ΟΥΝΟΜΑΤΑ ΠΡΟΣΩΠΩΝ
 ΟΥΝΟΜΑΤΑ ΠΡΟΣΩΠΩΝ
 ΟΥΝΟΜΑΤΑ ΠΡΟΣΩΠΩΝ
 ΟΥΝΟΜΑΤΑ ΠΡΟΣΩΠΩΝ
 ΟΥΝΟΜΑΤΑ ΠΡΟΣΩΠΩΝ

ΟΥΝΟΜΑΤΑ ΠΡΟΣΩΠΩΝ	ΟΥΝΟΜΑΤΑ ΠΡΟΣΩΠΩΝ				ΟΥΝΟΜΑΤΑ ΠΡΟΣΩΠΩΝ				ΟΥΝΟΜΑΤΑ ΠΡΟΣΩΠΩΝ				ΟΥΝΟΜΑΤΑ ΠΡΟΣΩΠΩΝ			
	Σ^c	V@	Uā @	U^a•	Σ^c	V@	Uā @	U^a•	Σ^c	V@	Uā @	U^a•	Σ^c	V@	Uā @	U^a•
ΕΙ ΚΕΑΥΤ	Ι	FI	€	€	Ι	€	GH	€	€	FI	Ι	€	€	€	€	€
ΕΙ ΚΕΙ ΑΥΤ	F	FI	€	€	Ι	€	GI	€	€	FI	Ι	€	€	€	€	€
ΕΙ ΚΕΑΥΤ	G	FE	€	€	Ι	€	GH	€	€	Ι	F	€	€	€	€	€
ΕΙ ΚΕΙ ΑΥΤ	I	OE	€	€	H	€	FG	€	€	FI	Ι	€	€	€	€	€
ΕΙ ΚΕΑΥΤ	Ι	GH	€	€	H	€	Ι	€	€	Ι	Ι	€	€	€	€	€
ΕΙ ΚΕΙ ΑΥΤ	FI	FI	€	€	G	€	H	€	€	FH	Ι	€	€	€	€	€
ΕΙ ΚΕΑΥΤ	I	FG	€	€	G	€	Ι	€	€	FI	H	€	€	€	€	€
ΕΙ ΚΕΙ ΑΥΤ	I	FI	€	€	I	€	F	€	€	Ι	I	€	€	€	€	€

Ō[]•ŌÁŷĭā ā•áŌ&Ē
 ŪŪŌŷ cĀFĪĭ
 Ō[]•áŌŌŷĜĭĭ
 ĞĪFĊĪĒĒĪ

Ōā: Ā-Ō[]•ĀŌā&@
 PĒŪKŌŌā ĤāāŪd^c
 ŌĒY KĀ[]•ĭc^āāŌ[]•ĭcāāŪā]
 Y^ā&@:KĀ[]•ĭc^āāŌ[]•ĭcāāŪā]

Ōā: ĀāĤ ĤŌŌŌŌŌŪŌŌĒ
 Ūā: ŌŌĭ āĤ ĤĒĒĒĒĒĒFF
 Ūā: ŌŌāĤ ĤĊĊĊĒĒĒFG
 Ūā: ĀŌ[] ĤĤ

Ō[]•Ūĭā cāĒŪā•Ĥ•ĤĀĤĊĀ•ĤŌŌ ācāĀĭ• &•ĤŌŌ cāĀŪĭ•ĭĀĭ• &•ĤŌŌ cāĀĀĭ• &•ĤŪŌcĀĀĭ• &•

ŪācāĀĭ ^	ŌāĤ ĤāāŪd^c Ūĭcā[]ā			Ū[]•ĭc^āāŌ[]•ĭcāā Y^•cā[]ā			ŌāĤ ĤāāŪd^c P[]cā[]ā			QcĀ[]cā
	Ŷ-c	V@	Ō[]ĒV[]cā	Ŷ-c	Ūā @	Ō[]ĒV[]cā	V@	Ūā @	Ō[]ĒV[]cā	
ĒĪĒĒĒĒ	ĪĪ	FĪ€	ĠĪ	Ī	H	HĪ	ĪĪ	FH	FĒF	HĪĪ
ĒĪĪĪĒĒ	ĪĪ	FĪF	ĠĠ	FĒ	H	ĪĪ	JĒ	FĒ	FĒĒ	HĪĪ
ĒĪĤĒĒĒ	ĪJ	ĠĪ	HĪ	FĪ	ĪJ	ĪH	FĠ	FH	FĪ€	ĪĒJ
ĒĪĪĪĒĒ	ĪF	FĪĪ	ĠĪ	FĪ	ĪĪ	ĪĠ	FĒĪ	G	FĒĪ	ĪFĪ
V[]cā	ĠĠ	ĪĪĪ	ĠĪJ	ĪĪ	FĪĪ	ĠĠĒ	ĪĒJ	H	ĪĪĪ	FĪĪĪ
ĒĪĒĒĒĒ	HĪ	FĪG	FĪĪ	FĪ	H	ĪĠ	JĪ	Ī	FĒG	HĪG
ĒĪĪĪĒĒ	Ī€	FĪJ	ĠFJ	FĒ	HĠ	ĪĠ	ĪH	FĒ	JH	HĪĪ
ĒĪĤĒĒĒ	ĪF	FĠ	FĪĪ	J	H	ĪĪ	JĒ	FĪ	FĒĪ	HĪĪ
ĒĪĪĪĒĒ	ĪG	FĒĪ	FĪĪ	J	H	ĪH	ĪĪ	FĪ	FĒH	HĒG
V[]cā	FĪJ	ĪĪJ	ĪHĪ	ĪG	FĪG	FĪĪ	HĪĪ	ĪĪ	ĪĒ	FĠĠ
Ō[]•āĀ[]cā	ĪĒH	FĠG	FĪĠ	ĪĪ	HĪĪ	ĪĒ	ĪĪĪ	ĪĪ	ĪĪF	ĠĪĠ
Ō[]•ĭ&ŌĀ	ĠĒĪ	ĪĪĒ	Ī	ĠĒĒ	ĪĪĒ	ĪĒ	ĪĪĪ	FĒĒ	Ī	Ī
V[]cāĀ	FĠĒ	ĪĪĒ	ĪĪĪ	ĠĒ	FĒĒ	FĠĒ	ĠĒĒ	ĠĒ	ĠĒĒ	ĠĒĒ
Ūā•Ĥ•ĤĀĤĊĀ•	ĠĪ	JĪ€	FFĪĪ	ĪĠ	ĠĠ	ĠF	ĪĒ	Ġ	ĪH	FĪĪ€
ĀŪā•Ĥ•ĤĀĤĊĀ•	ĪĪĪ	ĪĪĒ	ĪĪĒ	ĪĪĒ	ĪĠĒ	ĪĠĒ	ĪĪĒ	HĒG	ĪĠĒ	ĪĪĒ
Ō[]•cāĀĭ• &•	FĠ	FFF	ĠHĪ	FĪ	FĒ	Ġ	ĪĠ	HĪ	ĪJ	HĪ
ĀŌ[]•cāĀĭ• &•	HĒĒ	ĪĒ	FĠĒ	FĪĒ	HĒG	ĪĒ	ĪĒ	ĪH	JĒĪ	FFĒ
ŌcāĀŪĭ•ĭĀĭ• &•	F	ĠĒ	ĠF	€	F	F	G	€	G	G
ĀŌcāĀŪĭ•ĭĀĭ• &•	ĠĠ	FĒ	FĒG	€	ĠĪ	ĠĠ	ĠĪ	€	ĠĠ	ĠĪ
Ō[]•cāĀĭ• &•	FH	ĪĪ	JĪ	FG	H	ĪĪ	ĪJ	Ī	ĪĪ	ĠĠ
ĀŌ[]•cāĀĭ• &•	HĠ	ĪĒ	ĪĒ	FĠĒ	FFĒ	FFĒ	J	Ī	ĪĒ	ĪĒ
ŪcāĀĭ• &•	ĪĪ	FĪĪ	ĠĒ	Ī	ĪF	ĪĪ	FĪĪ	FĪ	FĪF	ĪFH
ĀŪcāĀĭ• &•	FFĒ	FFĪ	FFĒ	Ī	FGĪ	FFĪ	FĪĒ	FĪĒ	FĪĪ	FĠĒ

ŪācāĀĭ ^	ŌāĤ ĤāāŪd^c Ūĭcā[]ā			Ū[]•ĭc^āāŌ[]•ĭcāā Y^•cā[]ā			ŌāĤ ĤāāŪd^c P[]cā[]ā			QcĀ[]cā
	Ŷ-c	V@	Ō[]ĒV[]cā	Ŷ-c	Ūā @	Ō[]ĒV[]cā	V@	Ūā @	Ō[]ĒV[]cā	
ŪāāĀĭ•ĭĀĭ• &•	ĪĪ	FĪ€	ĠĪ	Ī	H	HĪ	ĪĪ	13	FĒF	HĪĪ
ŪāāĀĭ•ĭĀĭ• &•	67	FĪF	ĠĠ	FĒ	H	ĪĪ	JĒ	FĒ	FĒĒ	HĪĪ
ŪāāĀĭ•ĭĀĭ• &•	ĪJ	247	306	FĪ	ĪJ	ĪH	127	FH	140	509
ŪāāĀĭ•ĭĀĭ• &•	ĪF	FĪĪ	ĠĪ	17	55	72	FĒĪ	G	FĒĪ	ĪFĪ
V[]cāĀ[]•ĭĀĭ• &•	ĠĠ	ĪĪĪ	ĠĪJ	ĪĪ	FĪĪ	ĠĠĒ	ĪĒJ	H	ĪĪĪ	FĪĪĪ
ĀŌ[]ĒV[]cā	ĠĠĒ	ĪĪĒ	Ī	ĠĠĒ	ĪĪĒ	Ī	JĠĒ	ĪĒ	Ī	Ī
UPØ	ĒĪĪ	ĒĪĪ	ĒĪĪ	ĒĪĠ	ĒĪĪ	ĒĪĪ	ĒĪĪ	ĒĪF	ĒĪĪ	ĒĪFH

Ö[] *ÄM|ä ääÄÖ&É
 UUÄÖ cÄFI
 Ö[] äÖÖÄGii
 QI FÖG i È G i

Öä Ä -Ä[] *Ä^ä@
 PÄUÄÖÄ äääÄd^^c
 ÖEY ÄU^] |ç^ääÖ[] ^çääÄUä]
 Y ^ää@:ÄU^ } } ^

Ö^ Ä ä ^ KÖÖÖÖSÜÖÖF
 Uä Ä Ö[] ä ^ KÉÉÉÉÉFF
 Uää Ö ä ^ KÖÖÖ BÖÖFG
 Uä Ä Ä[] KÖG

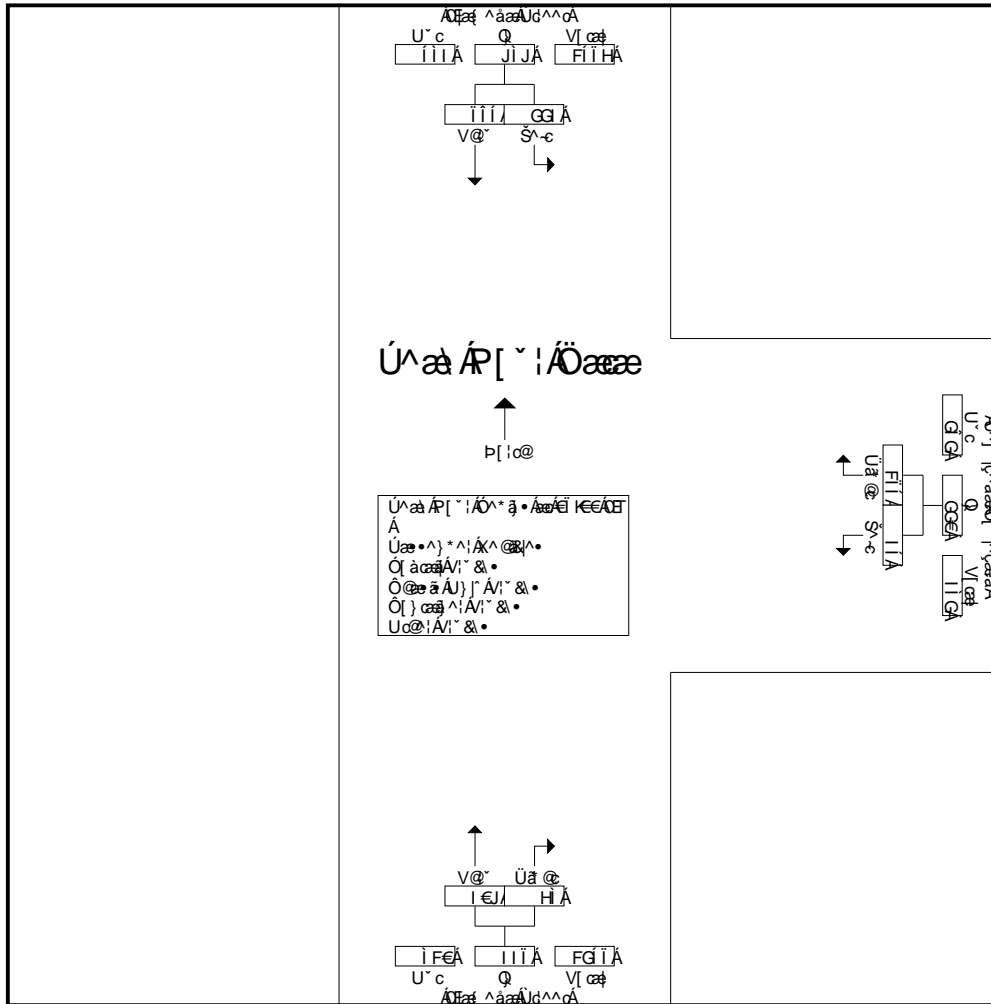

U^ä Ä P[] ^ | Ä Ö ä ä ä
 U^ä Ä P[] ^ | Ä Ö ä ä ä

	Ä K Ö Ö F			Ä K I Ä Ö F			Ä K I Ä Ö F		
ÉÉÄ ä • È	ii	Fí €	Gfí	F€	Hj	Ii	J€	F€	F€€
ÉFí Ä ä • È	67	Fí F	Ggí	Fí	I J	Í H	127	13	140
ÉHÄ ä • È	í J	247	306	17	55	72	F€í	G	F€í
Éí Ä ä • È	I F	FJí	Gí	Fí	Hí	Í G	Jí	í	F€G
V I öä K I] ^ ^	G G	I I I	J I J	I I	F I J	G H	I F I	H G	I I I
Ä Ö H] E V] öä	G G F	I I È	Ä	G H È	I I È	Ä	J Ö È	í È	Ä
U P Ø	È H	È I I	È €	È €	È F I	È F H	È F J	È F I	È €€

Ó[~]•ÁM|ã àáÁQ&É
 ÚUÁÓ ÇÁFÍÍ
 Ó[~]•ÁM|ã àáÁQ&É
 QÍFQÍÉÍ

Óã Á-Á[~]•ÁQ&É@
 ÞEJÍKÍÁF ááÁÚdÁÁÚÁF]
 ÓEY KÁ[~]•ÁQ&É[~]•ÁQ&É
 Y^Á@:KÁ[~]•ÁQ&É}}

Óã Á-Á[~]•ÁQ&É@ KÍÓÓÓÓÓÓÓÓ
 Úã Á-Á[~]•ÁQ&É@ KÍÉÉÉÉÉÉÉÉ
 Úã ÓÓÓÓ KÍGÍJÍBÉFÍG
 Úã Á-Á[~]•ÁQ&É@ KÍ

Ó[~]•ÁM|ã àáÁQ&É*^Á^Á^Á^

Úã ÓÓÓÓ Á^	Óã Á-Á[~]•ÁQ&É@ Ú[~]•ÁQ&É[~]•ÁQ&É				Ú[~]•ÁQ&É@ Y^Á^Á^Á^				Ú[~]•ÁQ&É@ P[~]•ÁQ&É[~]•ÁQ&É				Ú[~]•ÁQ&É@ Óã ÓÓÓÓ				Q dÁV[~]•ÁQ&É
	Š^c	V@~	Úã @	Q[~]ÉV[~]•ÁQ&É	Š^c	V@~	Úã @	Q[~]ÉV[~]•ÁQ&É	Š^c	V@~	Úã @	Q[~]ÉV[~]•ÁQ&É	Š^c	V@~	Úã @	Q[~]ÉV[~]•ÁQ&É	
ÉÍ KÍ ÁQ&É	FG	H	FÍ	HG	G	FGJ	FÍ	FÍÍ	€	€	€	€	FJ	íí	€	íí	GÍ
ÉÍ KÍ ÁQ&É	FH	F	G	HJ	F	FÍÍ	F€	FÍÍ	€	€	F	F	FÍ	ìG	€	JÍ	GJF
ÉÍ KÍ ÁQ&É	FÍ	F	GH	IE	F	FÍG	HG	FÍÍ	€	€	H	H	FÍ	íí	€	F€	HH
ÉÍ KÍ ÁQ&É	FF	€	GF	HG	H	FÍF	GE	FÍÍ	F	F	€	G	HG	JG	€	FG	HG
V[~]•ÁQ&É	IG	í	íí	FÍH	í	ííí	íJ	ííG	F	F	í	í	ìG	HG	€	IFE	FGFF
ÉÍ KÍ ÁQ&É	FG	F	HF	II	G	FQ	GE	FÍÍ	F	F	F	H	GE	íí	€	F€	HEG
ÉÍ KÍ ÁQ&É	í	€	F€	FÍ	G	F€€	FG	FFÍ	F	F	F	H	FÍ	íí	€	JG	GÍ
ÉÍ KÍ ÁQ&É	FÍ	F	J	G	F	íí	F€	JJ	€	€	F	F	FÍ	íí	F	íí	FÍÍ
ÉÍ KÍ ÁQ&É	í	€	FH	GF	€	íí	í	íí	€	F	€	F	FÍ	íJ	G	íí	FÍH
V[~]•ÁQ&É	IG	G	ÍH	F€	í	HJ	IE	IH	G	H	H	í	íí	G	F	H	H
Ó[~]•ÁQ&É	JÍ	í	FÍJ	G€	FG	JÍÍ	FGJ	F€Í	H	í	í	FÍ	FÍJ	íJJ	H	ííF	GF€
Q[~]•ÁQ&É	HÍ	€	íJ€	Á	F€	íí	FF€	Á	G€	G€	í€	Á	FJ€	íJ€	€	Á	Á
V[~]•ÁQ&É	IE	€	í€	FF€	€	íí	í€	í€	€	€	€	€	í€	G€	€	HÍ€	

Úã ÓÓÓÓ Á^	Óã Á-Á[~]•ÁQ&É@ Ú[~]•ÁQ&É[~]•ÁQ&É				Ú[~]•ÁQ&É@ Y^Á^Á^Á^				Ú[~]•ÁQ&É@ P[~]•ÁQ&É[~]•ÁQ&É				Ú[~]•ÁQ&É@ Óã ÓÓÓÓ				Q dÁV[~]•ÁQ&É
	Š^c	V@~	Úã @	Q[~]ÉV[~]•ÁQ&É	Š^c	V@~	Úã @	Q[~]ÉV[~]•ÁQ&É	Š^c	V@~	Úã @	Q[~]ÉV[~]•ÁQ&É	Š^c	V@~	Úã @	Q[~]ÉV[~]•ÁQ&É	
Úã Á-Á[~]•ÁQ&É@																	
ÉÍ KÍ ÁQ&É	FH	1	G	HJ	F	FÍÍ	F€	FÍÍ	€	€	F	F	FÍ	ìG	€	JÍ	GJF
ÉÍ KÍ ÁQ&É	16	F	GH	IE	F	152	32	185	€	€	3	3	FÍ	íí	€	F€	333
ÉÍ KÍ ÁQ&É	FF	€	GF	HG	3	FÍF	GE	FÍÍ	1	1	€	G	32	92	€	124	HG
ÉÍ KÍ ÁQ&É	FG	F	31	44	G	FQ	GE	FÍÍ	F	F	F	H	GE	íí	€	F€	HEG
V[~]•ÁQ&É	IG	H	F€€	FÍÍ	í	ííG	IG	ííF	G	G	í	J	ìH	H€	€	ííH	FGÍ
Á-Á[~]•ÁQ&É	HÍ	F€	íí€	Á	F€	íí€	FQ€	Á	G€	G€	íí€	Á	FJ€	íí€	€	Á	Á
UPØ	€FH	€€	€€	€F	€H	€G	€F	€€	€€	€€	€F	€€	€€	€€	€€	€H	€H

Ó[~ } , o ÁM |ã ,ãããQ&E
 UUÁQ cÁFII
 Ó[!:]ããÖÖÁGII
 QI FÁG I È Ñ I

Óã Á -Á[] * ÁO^ã&@
 ÞEUIKÖEã ãã^ÁUd^ãcÁUã]
 ÖEY KÁU^]ç^ããÖ[^çããã
 Y ^ãã@:KÁ^ } } ^

Ö^ ÁPã ^ KÖÖÖÖÖÖÖÖÖÖ
 Úã ÁÖI á^ KÉÉÉÉÉÉÉÉÉÉ
 ÚããcÖãã KÖGJ BDEFG
 Úãã^ÁP[KÖG

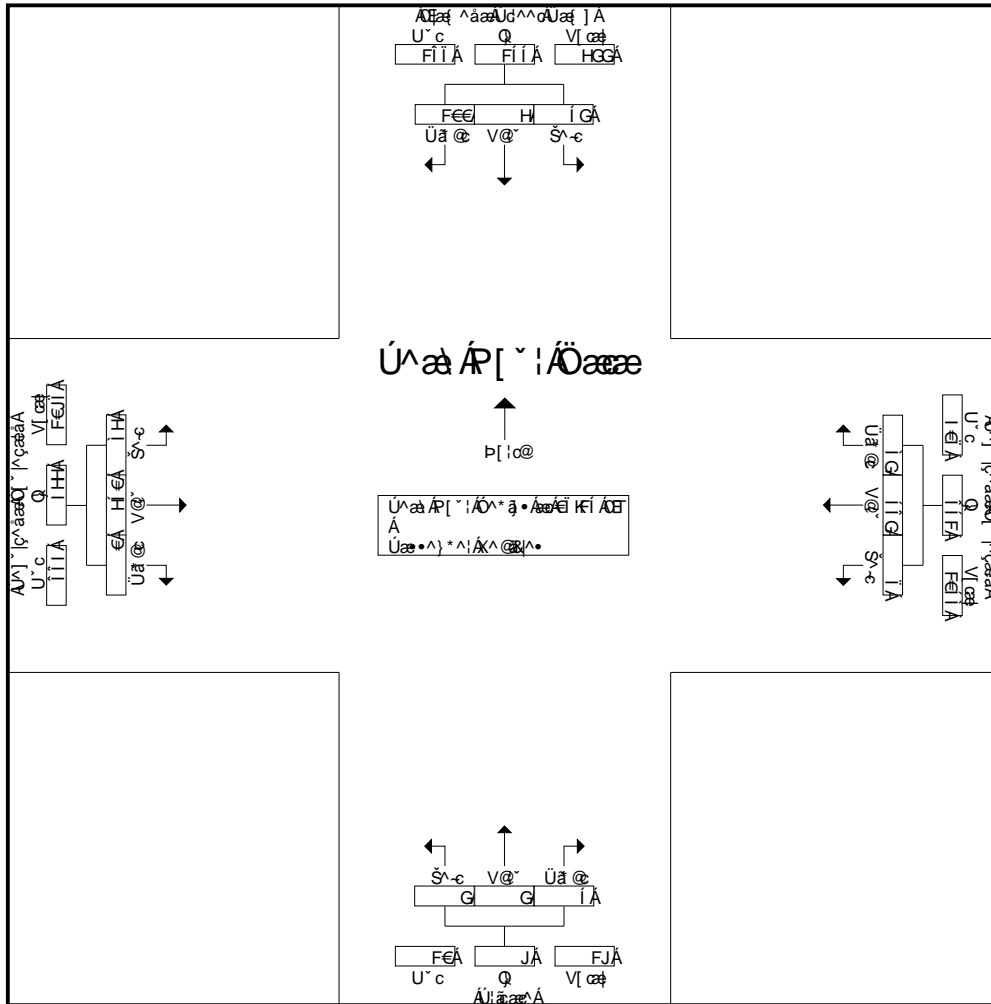

Úãã ÁP[~ ! ÖÖããë * ÁPãã KFI ÁÖE ÁPãã KFI ÁÖE ÁPãã KFI ÁÖE ÁPãã KFI ÁÖE
 Úãã ÁP[~ ! ÖÖããë * ÁPãã KFI ÁÖE ÁPãã KFI ÁÖE ÁPãã KFI ÁÖE ÁPãã KFI ÁÖE

	éi kfi ÁÖE				éi kfi ÁÖE				éi kfi ÁÖE				éi kfi ÁÖE			
ÉÉÁ á·È	FH	1	G	HJ	F	FII	FÉ	FÍ	€	€	F	F	FI	ìG	€	JÍ
ÉFÍ Á á·È	16	F	GH	I€	F	152	32	185	€	€	3	3	Fí	ìì	€	Féi
ÉHEÁ á·È	FF	€	GF	HG	3	FIF	ÖE	FÍI	1	1	€	G	32	92	€	124
ÉIÁ á·È	FG	F	31	44	G	FG	ÖE	FII	F	F	F	H	ÖE	ìì	€	Féi
VI cãëK[]ç^	IG	H	FEE	FII	í	íIG	IG	íIF	G	G	í	J	ìH	Hí€	€	IHH
Á ÁÖI]ÉV[cãë	HÉ	FÈ	ììÈ	Á	FÈ	ììÈ	FÖÈ	Á	ÖÖG	ÖÖG	íìÈ	Á	FJÈ	ìÈÈ	€	Á
UPÖ	ÈFH	Èí€	Èé	ÈíF	ÈíH	ÈG	ÈíF	Èí€	Èé€	Èé€	ÈFí	Èí€	Èíì	ÈíF	Èé€	ÈíH

Ó[~]•ÁV]ã áãÁQ&É
 ÚUÁÓ]çÁFI
 Ó[~]ãÉÓÇÁGII
 QIFDGIÉGI

Óã Á -Á[] * Á^ã&@
 PDUKÓÇã áãÁUd^^ÁUã]
 ÓEY KÁV]~|ç^áãÁÓ~|ççáã
 Y^ã&@:KÁV]}}~

Óã Á çã ^ K\$ÓÓÇSÙÓÇE
 Úã Á Ó] á^ KÉÉÉÉÉÉÉF
 Úã Ó Óãã KÇBJBDEF
 Úã Á Á[KÁ

Ó[~]•ÁUã çãÉÓÇãÁU]~ÁV]~&•

Úã Ó Á V] ^	ÓÇã ^áãÁUd^^ÁUã] Ú~çã[~] á				Ú~ ç^áãÁÓ~ ççáã Y^•çã[~] á				Ú~çãã P[~çã[~] á				Ú~ ç^áãÁÓ~ ççáã Óã çã[~] á				Q çã V] çã
	Š^ç	V@~	Úã @	ç] ÈV] çã	Š^ç	V@~	Úã @	ç] ÈV] çã	Š^ç	V@~	Úã @	ç] ÈV] çã	Š^ç	V@~	Úã @	ç] ÈV] çã	
ÈI KÉÁÓE	€	€	€	€	€	€	€	€	€	€	€	€	€	€	€	€	€
ÈI KI ÁÓE	F	€	€	F	€	€	€	€	€	€	€	€	€	€	€	€	F
ÈI KÍ ÁÓE	€	€	€	€	€	€	€	€	€	€	€	€	F	€	€	F	F
ÈI KI ÁÓE	€	€	€	€	€	€	€	€	€	€	€	€	H	€	€	H	H
V] çã	F	€	€	F	€	€	€	€	€	€	€	€	I	€	€	I	I
ÈI KÉÁÓE	€	€	F	F	€	€	€	€	€	€	€	€	F	€	€	F	G
ÈI KI ÁÓE	€	€	€	€	€	€	€	€	€	€	€	€	€	€	€	€	€
ÈI KÍ ÁÓE	€	€	€	€	€	€	H	H	€	€	€	€	F	€	€	F	I
ÈI KI ÁÓE	F	€	€	F	€	€	H	H	€	€	€	€	€	F	€	F	I
V] çã	F	€	F	G	€	€	I	I	€	€	€	€	G	F	€	H	FF
Ó:]ã áÁ[çã	G	€	F	H	€	€	I	I	€	€	€	€	I	F	€	I	F I
Ó:]ã & ÇÁ	I I È	€	H ÈH	Á	€	€	F ÈÈ	Á	€	€	€	Á	I I È	F I ÈH	€	Á	Á
V] çã Á	F ÈÈ	€	I ÈÈ	F I ÈÈ	€	€	H ÈÈ	H ÈÈ	€	€	€	€	H ÈÈ	I ÈÈ	€	I ÈÈ	

Úã Ó Á V] ^	ÓÇã ^áãÁUd^^ÁUã] Ú~çã[~] á				Ú~ ç^áãÁÓ~ ççáã Y^•çã[~] á				Ú~çãã P[~çã[~] á				Ú~ ç^áãÁÓ~ ççáã Óã çã[~] á				Q çã V] çã
	Š^ç	V@~	Úã @	ç] ÈV] çã	Š^ç	V@~	Úã @	ç] ÈV] çã	Š^ç	V@~	Úã @	ç] ÈV] çã	Š^ç	V@~	Úã @	ç] ÈV] çã	
Úã Á P[~] ÁÓE çã • á ÁÓ[{ ÁE KI ÁÓE ÁE KI KÉÁÓE ÁUã çã Á Á -Á																	
Úã Á P[~] Á[ÁÓ] çã ÁÓ çã! ^ & çã } ÁÓ^ á • Áã ÁE KI ÁÓE																	
ÈI KI ÁÓE	1	€	€	1	€	€	€	€	€	€	€	€	€	€	€	€	F
ÈI KÍ ÁÓE	€	€	€	€	€	€	€	€	€	€	€	€	F	€	€	F	F
ÈI KI ÁÓE	€	€	€	€	€	€	€	€	€	€	€	€	3	€	€	3	3
ÈI KÉÁÓE	€	€	1	F	€	€	€	€	€	€	€	€	F	€	€	F	G
V] çã Á[] ^	F	€	F	G	€	€	€	€	€	€	€	€	I	€	€	I	I
Á ÁÓE] ÈV] çã	I	€	I	Á	€	€	€	Á	€	€	€	Á	F	€	€	Á	Á
UPØ	ÈÈ	€	ÈÈÈ	ÈÈ	ÈÈÈÈ	ÈÈÈÈ	ÈÈÈÈ	ÈÈÈÈ	ÈÈÈÈ	ÈÈÈÈ	ÈÈÈÈ	ÈÈÈÈ	ÈÈÈÈ	ÈÈÈÈ	ÈÈÈÈ	ÈÈÈÈ	ÈÈÈÈ

Ô[] * ÁM |ã äãÁQ&É
 UUÁQ cÁFII
 Ô[] äãÁQ&É
 QI FÁI È Ñ I

Ôã Á -Á[] * ÁQ&@
 ÞEUIKQ&äãÁUd^^cÁUä]
 ÖEY KÁU] |ç^ääÁQ | ^çää
 Y ^ää@:KÁ } } ^

Ôã ÁQ& ^ KŠÓÓCŠÜÖE
 Uä ÁQ ä ^ KÉÉÉÉÉÉF
 Uää Öää KCBJ BDEFG
 Uää ÁQ KĠ

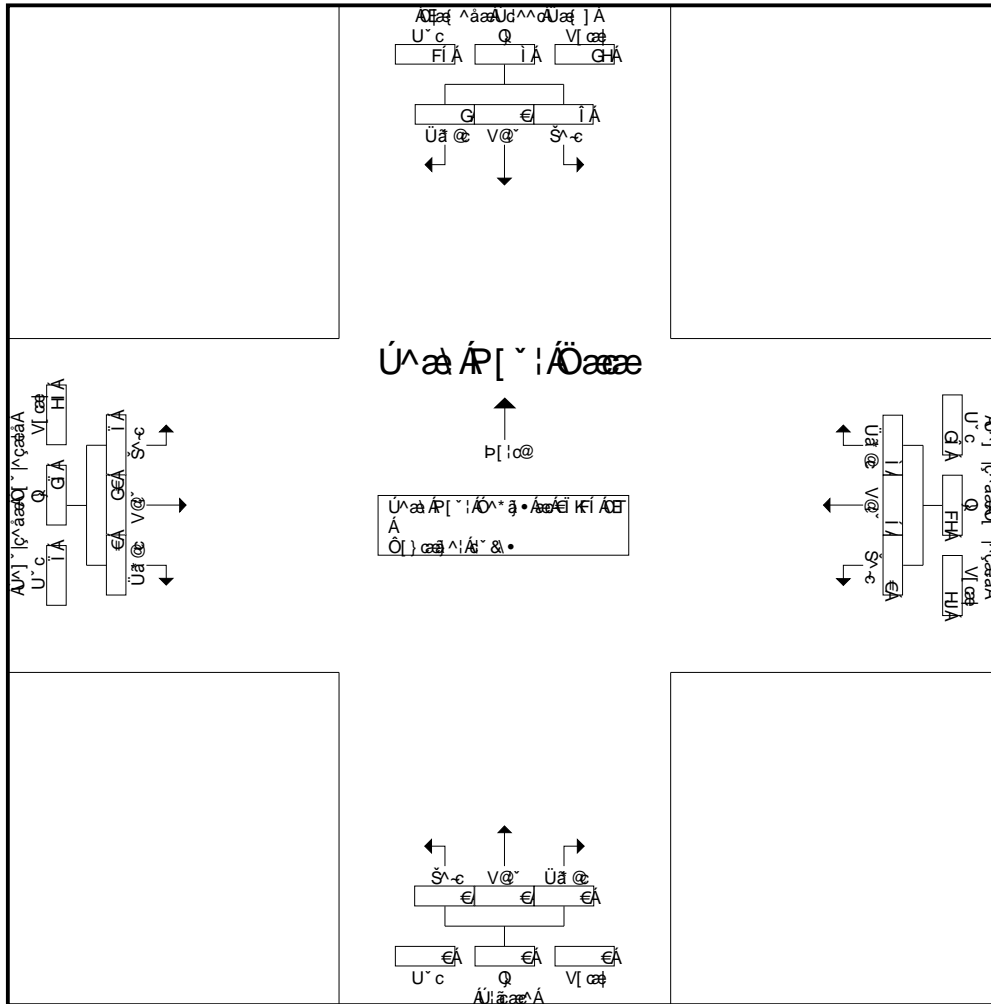

Úää ÁR[] ÁQ& äã ÁQ[] ÁE KFI ÁE ÁE KÉÁE ÁU^ää ÁFÁ -F
 Úää ÁR[] ÁQ[] ÁQ&@Q[] äãÁQ^ã ÁK

	éi KFI ÁE				éi KFI ÁE				éi KFI ÁE				éi KFI ÁE			
ÉÉÁ äã È	F	€	€	F	€	F	H	I	€	€	€	€	F	í	€	í
ÉFÁ äã È	F	€	1	G	€	€	€	€	€	€	€	€	3	6	€	€
ÉHEÁ äã È	3	€	€	3	€	2	4	6	€	€	€	€	F	í	€	í
ÉIÁ äã È	F	€	F	G	€	G	F	H	€	€	€	€	G	H	€	í
VI çæK[] ^	í	€	G	í	€	í	í	FH	€	€	€	€	í	QÉ	€	Gí
Á ÁE] EÁV çæ	íí	€	G	Á	€	H	í	FÉ	€	€	€	€	G	È	í	É
UPØ	ÈÈ	ÈÈÈ	ÈÈÈÈ	ÈÈÈÈÈ	ÈÈÈÈÈ	ÈÈÈÈÈ	ÈÈÈÈÈ	ÈÈÈÈÈ	ÈÈÈÈÈ	ÈÈÈÈÈ	ÈÈÈÈÈ	ÈÈÈÈÈ	ÈÈÈÈÈ	ÈÈÈÈÈ	ÈÈÈÈÈ	ÈÈÈÈÈ

Ô[~],oÁM|ããáÁQ&É
 ÚUÁO|cÁFIÍ
 Ô[|:]ãÁOÖãGíí
 QI FDI Ì Ë Ì

Ôã: Á-Á[~]* ÁOã&@
 ÞDUKÔÇããã^ÁUd^^ÁUã]
 ÔEY KÁU~|c^áãÁ[~|cçãá
 Y^ã&@:KÁU}}^

Ôã ÁPã ^ KÖÖÖÖÖÖÖÖÖÖ
 Úã ÁO|ã^ KÉÉÉÉÉÉÉÉÉÉÉÉ
 Úã ÓÖã KÇGJBDÉFG
 Úã ÁP| KÄ

Ö[|~]•ÁUãããUc@:Á/|~&•

ÚãÓÁ/ã ^	ÔÇã ^áãÁUd^^ÁUã] Ú ~çã ~}á				Ú~ ç^áãÁO ~ cçãá Y^•cá ~}á				Ú ãçã P :cã ~}á				Ú~ ç^áãÁO ~ cçãá Ôããá ~}á				QdÁV çã
	Š~c	V@~	Úã@	Q ÉV çã	Š~c	V@~	Úã@	Q ÉV çã	Š~c	V@~	Úã@	Q ÉV çã	Š~c	V@~	Úã@	Q ÉV çã	QdÁV çã
È KÉÁOÉ	F	l	€	í	G	l	€	í	l	F	F	í	€	H	í	í	G
È KíÁOÉ	€	F	€	F	l	l	€	í	l	í	G	FH	€	l	H	í	GJ
È KíÁOÉ	€	H	€	H	G	l	€	í	G	G	€	l	€	í	l	j	GH
È KíÁOÉ	€	l	G	í	€	l	F	í	H	l	F	í	€	í	G	í	G
V çã	F	FG	G	Fí	í	Fí	F	G	FH	Fl	l	HF	€	Fí	Fl	HF	FéH
È KÉÁOÉ	F	G	G	í	€	l	G	í	€	G	€	G	G	l	€	í	FJ
È KíÁOÉ	F	F	H	í	€	í	G	í	€	l	€	l	G	í	€	í	G
È KíÁOÉ	G	G	í	F€	€	í	H	í	€	€	€	€	G	í	€	í	G
È KíÁOÉ	H	F	H	í	€	í	F	í	€	H	€	H	€	í	€	í	G
V çã	í	í	Fí	G	€	Ö€	l	G	€	J	€	J	í	GH	€	GJ	JH
Ö ã:áÁ/çã	l	Fí	Fí	IG	l	Hí	J	íI	FH	GH	l	l€	í	l€	Fí	í€	FJí
Q :]&ÖÁ	FJ	IG	Hí	Á	Fí	íí	Fí	Á	HÖí	íí	F€	Á	F€	íí	Gíí	Á	Á
V çã	í	J	í	Gí	í	Fí	í	Gí	í	í	G	Öí	Hí	Öí	íí	Hí	í

ÚãÓÁ/ã ^	ÔÇã ^áãÁUd^^ÁUã] Ú ~çã ~}á				Ú~ ç^áãÁO ~ cçãá Y^•cá ~}á				Ú ãçã P :cã ~}á				Ú~ ç^áãÁO ~ cçãá Ôããá ~}á				QdÁV çã
	Š~c	V@~	Úã@	Q ÉV çã	Š~c	V@~	Úã@	Q ÉV çã	Š~c	V@~	Úã@	Q ÉV çã	Š~c	V@~	Úã@	Q ÉV çã	QdÁV çã
È KíÁOÉ	€	F	€	F	4	l	€	8	4	7	2	13	€	l	H	í	29
È KíÁOÉ	€	H	€	H	G	5	€	í	G	G	€	l	€	5	4	9	GH
È KíÁOÉ	€	4	2	6	€	l	F	í	H	l	F	í	€	í	G	í	G
È KÉÁOÉ	1	G	G	í	€	l	2	í	€	G	€	G	2	l	€	í	FJ
V çãK { ^	F	F€	l	Fí	í	Fí	H	G	J	Fl	H	G	G	Fl	J	GJ	Jí
Á ÁQ ÉV çã	íí	íí	Gí	Á	Gí	íí	íí	Á	Hí	íí	íí	Á	íí	íí	HF	Á	Á
UPØ	íí	€	íí	€€	íí	íí	€€	íí	íí	Hí	íí	íí	íí	íí	íí	íí	íí

01 ~ } o ÁM |ã ä á ÁQ&E
 UUÁO cÁFI I
 ÔI () aÉOÖÁG I i
 QI FDG i È G I

Ôã Á -S [] * Á^ã@
 PDUKÇã äãáÜd^ãÜã]
 ÖY KÁ^] [c^ããÔ] |cãã
 Y ^ã@:KÁ^ } } ^

Ôã Áã ^ KÖÖÖSUÖT Ö
 Üã ÁO] ä^ KÉÉÉÉÉ I
 Üã ÖÖã KGBJDFG
 Üã Á [K

Groups Printed- Passenger vehicles - Bobtail Trucks - Chasis Only Trucks - Container Trucks - Other trucks

Start Time	Alameda Street Ramp Southbound				Sepulveda Boulevard Westbound				Private Northbound				Sepulveda Boulevard Eastbound				Int. Total
	Left	Thru	Right	App. Total	Left	Thru	Right	App. Total	Left	Thru	Right	App. Total	Left	Thru	Right	App. Total	
01:00 PM	23	2	14	39	1	69	28	98	0	3	2	5	12	70	3	85	227
01:15 PM	27	3	15	45	1	65	27	93	1	2	1	4	21	63	0	84	226
01:30 PM	33	2	25	60	3	87	36	126	1	3	0	4	17	93	2	112	302
01:45 PM	32	2	25	59	1	91	42	134	3	3	1	7	20	90	0	110	310
Total	115	9	79	203	6	312	133	451	5	11	4	20	70	316	5	391	1065
02:00 PM	16	0	14	30	0	82	30	112	0	1	0	1	16	88	0	104	247
02:15 PM	19	0	16	35	0	79	29	108	1	1	1	3	15	89	0	104	250
02:30 PM	20	0	16	36	0	78	31	109	2	1	1	4	15	88	0	103	252
02:45 PM	26	0	10	36	0	79	33	112	2	0	0	2	16	103	0	119	269
Total	81	0	56	137	0	318	123	441	5	3	2	10	62	368	0	430	1018
Grand Total	196	9	135	340	6	630	256	892	10	14	6	30	132	684	5	821	2083
Approch %	57.6	2.6	39.7		0.7	70.6	28.7		33.3	46.7	20		16.1	83.3	0.6		
Total %	9.4	0.4	6.5	16.3	0.3	30.2	12.3	42.8	0.5	0.7	0.3	1.4	6.3	32.8	0.2	39.4	
Passenger vehicles	125	1	96	222	4	533	115	652	8	3	6	17	115	617	4	736	1627
% Passenger vehicles	63.8	11.1	71.1	65.3	66.7	84.6	44.9	73.1	80	21.4	100	56.7	87.1	90.2	80	89.6	78.1
Bobtail Trucks	16	0	14	30	1	68	89	158	0	2	0	2	7	23	0	30	220
% Bobtail Trucks	8.2	0	10.4	8.8	16.7	10.8	34.8	17.7	0	14.3	0	6.7	5.3	3.4	0	3.7	10.6
Chasis Only Trucks	7	0	4	11	0	5	23	28	0	0	0	0	0	1	0	1	40
% Chasis Only Trucks	3.6	0	3	3.2	0	0.8	9	3.1	0	0	0	0	0	0.1	0	0.1	1.9
Container Trucks	34	0	11	45	0	11	15	26	0	0	0	0	8	28	0	36	107
% Container Trucks	17.3	0	8.1	13.2	0	1.7	5.9	2.9	0	0	0	0	6.1	4.1	0	4.4	5.1
Other trucks	14	8	10	32	1	13	14	28	2	9	0	11	2	15	1	18	89
% Other trucks	7.1	88.9	7.4	9.4	16.7	2.1	5.5	3.1	20	64.3	0	36.7	1.5	2.2	20	2.2	4.3

Start Time	Alameda Street Ramp Southbound				Sepulveda Boulevard Westbound				Private Northbound				Sepulveda Boulevard Eastbound				Int. Total
	Left	Thru	Right	App. Total	Left	Thru	Right	App. Total	Left	Thru	Right	App. Total	Left	Thru	Right	App. Total	
01:30 PM	33	2	25	60	3	87	36	126	1	3	0	4	17	93	2	112	302
01:45 PM	32	2	25	59	1	91	42	134	3	3	1	7	20	90	0	110	310
02:00 PM	16	0	14	30	0	82	30	112	0	1	0	1	16	88	0	104	247
02:15 PM	19	0	16	35	0	79	29	108	1	1	1	3	15	89	0	104	250
Total Volume	100	4	80	184	4	339	137	480	5	8	2	15	68	360	2	430	1109
% App. Total	54.3	2.2	43.5		0.8	70.6	28.5		33.3	53.3	13.3		15.8	83.7	0.5		
PHF	.758	.500	.800	.767	.333	.931	.815	.896	.417	.667	.500	.536	.850	.968	.250	.960	.894

Peak Hour Analysis From 01:30 PM to 02:15 PM - Peak 1 of 1

Peak Hour for Entire Intersection Begins at 01:30 PM

Ö[] ÖÄ | ä ä Ä Ö &E
 UUÄ | c Ä F I I
 Ö[] | ä ä Ö Ä G I I
 Q I F D G I E G I

Öä Ä -Ä[] * Ä^ ä ä @
 P H U K C H ä ä Ä U d ^ Ä U ä]
 Ö E Y K Ä ^ | c ^ ä ä Ö | ^ c ä ä
 Y ^ ä ä @ : K Ä } } ^

Öä Ä ä ^ K S Ö Ö S U Ö T Ö
 U ä Ä Ö | ä ^ K E E E E E I
 U ä ä c Ö ä ä K G B J B D E F G
 U ä Ä Ä | K G

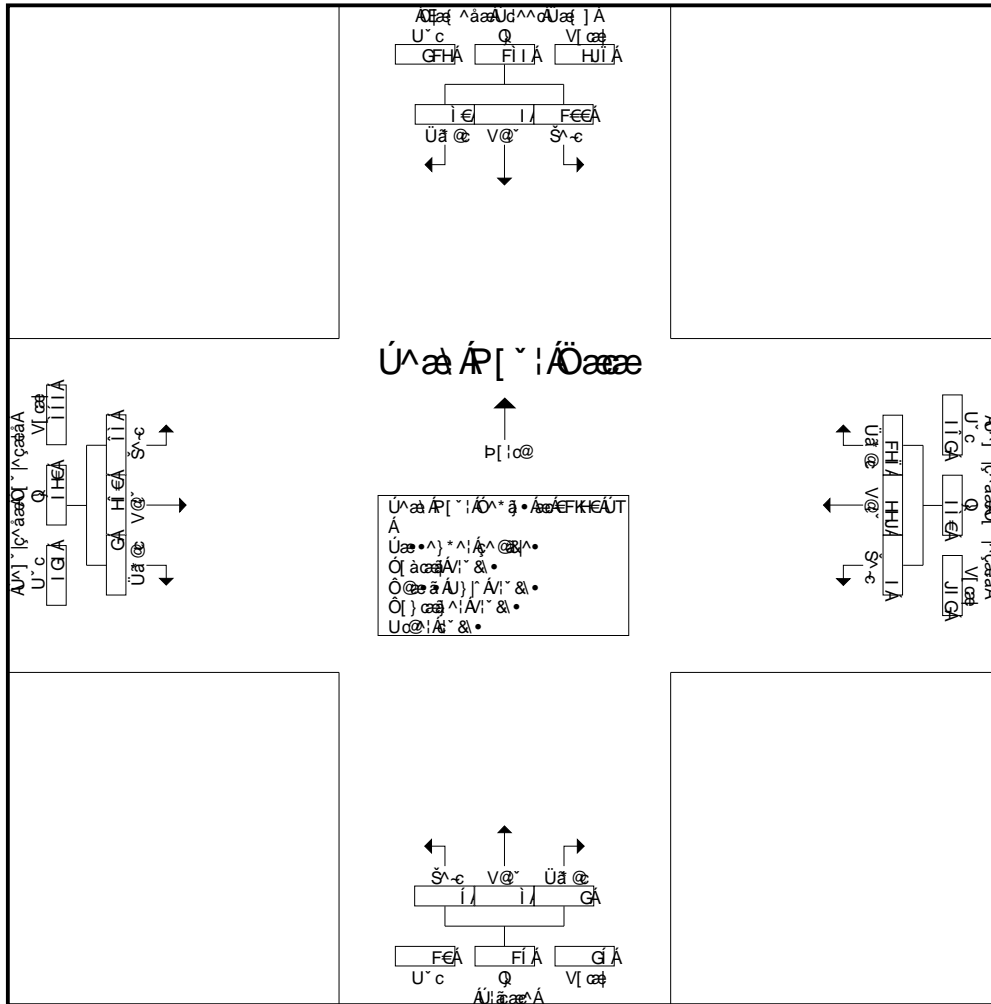

U^ä Ä P[] | Ä Ö ä ä ä { Ä F K E Ä U T Ä Ä E G H I Ä U T Ä Ä U^ä ä Ä Ä Ä
 Peak Hour for Each Approach Begins at:

	01:30 PM				01:30 PM				01:30 PM				01:30 PM			
+0 mins.	33	2	25	60	3	87	36	126	1	3	0	4	17	93	2	112
+15 mins.	32	2	25	59	1	91	42	134	3	3	1	7	20	90	0	110
+30 mins.	16	0	14	30	0	82	30	112	0	1	0	1	16	88	0	104
+45 mins.	19	0	16	35	0	79	29	108	1	1	1	3	15	89	0	104
Total Volume	100	4	80	184	4	339	137	480	5	8	2	15	68	360	2	430
% App. Total	54.3	2.2	43.5		0.8	70.6	28.5		33.3	53.3	13.3		15.8	83.7	0.5	
PHF	.758	.500	.800	.767	.333	.931	.815	.896	.417	.667	.500	.536	.850	.968	.250	.960

01:30 PM
 01:45 PM
 02:00 PM
 02:15 PM

01:30 PM
 01:45 PM
 02:00 PM
 02:15 PM

01:30 PM
 01:45 PM
 02:00 PM
 02:15 PM

Groups Printed- Passenger vehicles

Start Time	Alameda Street Ramp Southbound				Sepulveda Boulevard Westbound				Private Northbound				Sepulveda Boulevard Eastbound				Int. Total
	Left	Thru	Right	App. Total	Left	Thru	Right	App. Total	Left	Thru	Right	App. Total	Left	Thru	Right	App. Total	
01:00 PM	13	1	5	19	1	56	12	69	0	0	2	2	12	60	2	74	164
01:15 PM	7	0	8	15	0	53	13	66	0	0	1	1	13	49	0	62	144
01:30 PM	15	0	14	29	3	67	11	81	1	1	0	2	13	72	2	87	199
01:45 PM	13	0	15	28	0	74	18	92	2	0	1	3	17	81	0	98	221
Total	48	1	42	91	4	250	54	308	3	1	4	8	55	262	4	321	728
02:00 PM	15	0	14	29	0	72	16	88	0	1	0	1	16	84	0	100	218
02:15 PM	17	0	15	32	0	71	14	85	1	0	1	2	14	86	0	100	219
02:30 PM	19	0	16	35	0	69	16	85	2	1	1	4	15	84	0	99	223
02:45 PM	26	0	9	35	0	71	15	86	2	0	0	2	15	101	0	116	239
Total	77	0	54	131	0	283	61	344	5	2	2	9	60	355	0	415	899
Grand Total	125	1	96	222	4	533	115	652	8	3	6	17	115	617	4	736	1627
Apprch %	56.3	0.5	43.2		0.6	81.7	17.6		47.1	17.6	35.3		15.6	83.8	0.5		
Total %	7.7	0.1	5.9	13.6	0.2	32.8	7.1	40.1	0.5	0.2	0.4	1	7.1	37.9	0.2	45.2	

Start Time	Alameda Street Ramp Southbound				Sepulveda Boulevard Westbound				Private Northbound				Sepulveda Boulevard Eastbound				Int. Total
	Left	Thru	Right	App. Total	Left	Thru	Right	App. Total	Left	Thru	Right	App. Total	Left	Thru	Right	App. Total	
Peak Hour Analysis From 01:30 PM to 02:15 PM - Peak 1 of 1																	
Peak Hour for Entire Intersection Begins at 01:30 PM																	
01:30 PM	15	0	14	29	3	67	11	81	1	1	0	2	13	72	2	87	199
01:45 PM	13	0	15	28	0	74	18	92	2	0	1	3	17	81	0	98	221
02:00 PM	15	0	14	29	0	72	16	88	0	1	0	1	16	84	0	100	218
02:15 PM	17	0	15	32	0	71	14	85	1	0	1	2	14	86	0	100	219
Total Volume	60	0	58	118	3	284	59	346	4	2	2	8	60	323	2	385	857
% App. Total	50.8	0	49.2		0.9	82.1	17.1		50	25	25		15.6	83.9	0.5		
PHF	.882	.000	.967	.922	.250	.959	.819	.940	.500	.500	.500	.667	.882	.939	.250	.963	.969

0[~ } , 0 AM |ã, ãããQ&E
 UUÁQ cAFIi
 Ô[!:]ããÖÖÁGii
 QI FÁG i E d i

Ôã Á -S[] * ÁOãã@
 PBUKÇãã ^ããÁÜd^ãÜãã]
 ÖEY KÁ^ ^ [ç^ããÖ [^çããã
 Y ^ãã@:KÁ^ } } ^

Ôã Áãã ^ KÖÖÖÖÖÖÖÖ Ö
 Üã ÁÖ[ã^ KÖÖÖÖÖÖ Ö
 Üãã Öããã KÖÖÖÖÖÖ Ö
 Üãã Áã KÖ

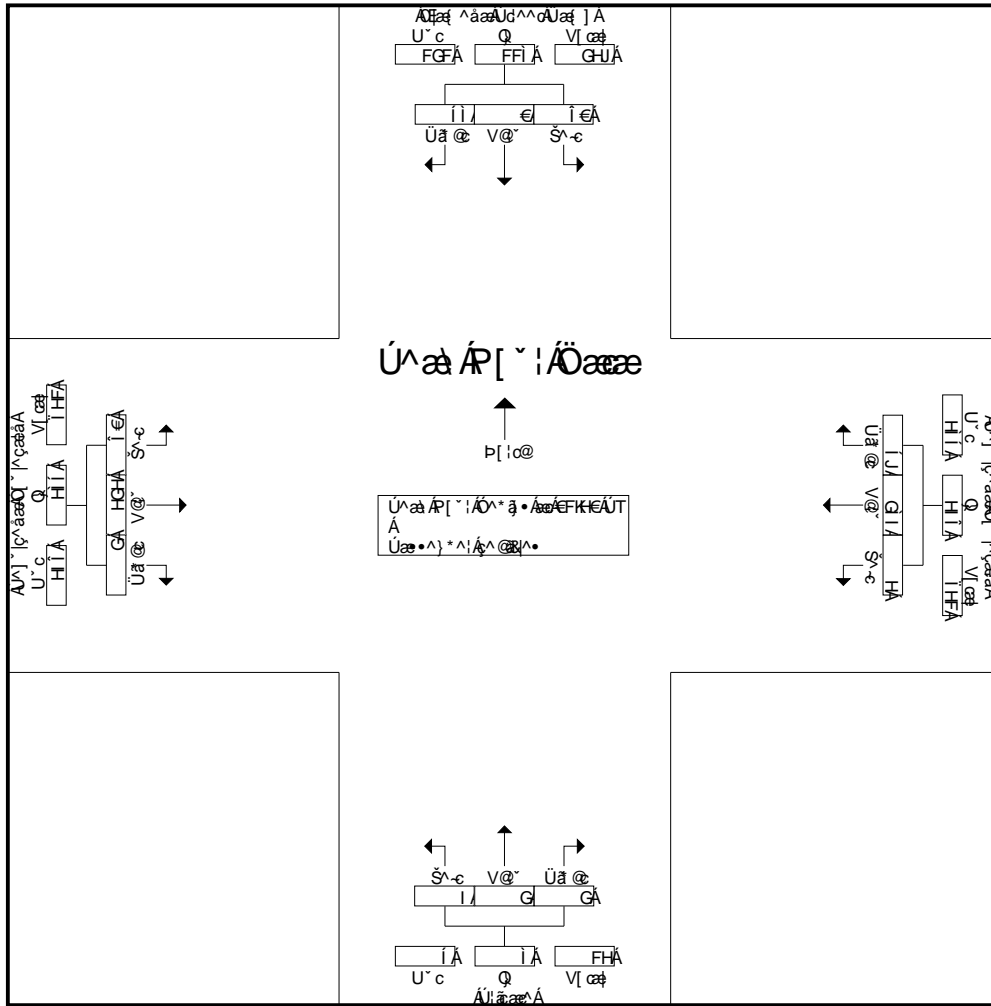

Üãã ÁP[~ !ÁÖããë • ã ÁÖ[{ ÁEFGHÁÜT ÁEFGHÁÜT ÁÜãã ÁEÁ -Á
 Peak Hour for Each Approach Begins at:

	01:30 PM				01:30 PM				01:30 PM				01:30 PM			
+0 mins.	15	0	14	29	3	67	11	81	1	1	0	2	13	72	2	87
+15 mins.	13	0	15	28	0	74	18	92	2	0	1	3	17	81	0	98
+30 mins.	15	0	14	29	0	72	16	88	0	1	0	1	16	84	0	100
+45 mins.	17	0	15	32	0	71	14	85	1	0	1	2	14	86	0	100
Total Volume	60	0	58	118	3	284	59	346	4	2	2	8	60	323	2	385
% App. Total	50.8	0	49.2		0.9	82.1	17.1		50	25	25		15.6	83.9	0.5	
PHF	.882	.000	.967	.922	.250	.959	.819	.940	.500	.500	.500	.667	.882	.939	.250	.963

01:00 AM 10:00 AM
 01:00 AM 10:00 AM
 01:00 AM 10:00 AM
 01:00 AM 10:00 AM

01:00 AM 10:00 AM
 01:00 AM 10:00 AM
 01:00 AM 10:00 AM
 01:00 AM 10:00 AM

01:00 AM 10:00 AM
 01:00 AM 10:00 AM
 01:00 AM 10:00 AM
 01:00 AM 10:00 AM

Groups Printed- Bobtail Trucks

Start Time	Alameda Street Ramp Southbound				Sepulveda Boulevard Westbound				Private Northbound				Sepulveda Boulevard Eastbound				Int. Total
	Left	Thru	Right	App. Total	Left	Thru	Right	App. Total	Left	Thru	Right	App. Total	Left	Thru	Right	App. Total	
01:00 PM	1	0	1	2	0	11	7	18	0	0	0	0	0	2	0	2	22
01:15 PM	5	0	4	9	1	5	4	10	0	0	0	0	3	2	0	5	24
01:30 PM	6	0	4	10	0	12	17	29	0	1	0	1	1	5	0	6	46
01:45 PM	4	0	5	9	0	8	10	18	0	0	0	0	1	1	0	2	29
Total	16	0	14	30	1	36	38	75	0	1	0	1	5	10	0	15	121
02:00 PM	0	0	0	0	0	9	11	20	0	0	0	0	0	4	0	4	24
02:15 PM	0	0	0	0	0	8	12	20	0	1	0	1	1	3	0	4	25
02:30 PM	0	0	0	0	0	8	13	21	0	0	0	0	0	4	0	4	25
02:45 PM	0	0	0	0	0	7	15	22	0	0	0	0	1	2	0	3	25
Total	0	0	0	0	0	32	51	83	0	1	0	1	2	13	0	15	99
Grand Total	16	0	14	30	1	68	89	158	0	2	0	2	7	23	0	30	220
Apprch %	53.3	0	46.7		0.6	43	56.3		0	100	0		23.3	76.7	0		
Total %	7.3	0	6.4	13.6	0.5	30.9	40.5	71.8	0	0.9	0	0.9	3.2	10.5	0	13.6	

Start Time	Alameda Street Ramp Southbound				Sepulveda Boulevard Westbound				Private Northbound				Sepulveda Boulevard Eastbound				Int. Total
	Left	Thru	Right	App. Total	Left	Thru	Right	App. Total	Left	Thru	Right	App. Total	Left	Thru	Right	App. Total	
Peak Hour Analysis From 01:30 PM to 02:15 PM - Peak 1 of 1																	
Peak Hour for Entire Intersection Begins at 01:30 PM																	
01:30 PM	6	0	4	10	0	12	17	29	0	1	0	1	1	5	0	6	46
01:45 PM	4	0	5	9	0	8	10	18	0	0	0	0	1	1	0	2	29
02:00 PM	0	0	0	0	0	9	11	20	0	0	0	0	0	4	0	4	24
02:15 PM	0	0	0	0	0	8	12	20	0	1	0	1	1	3	0	4	25
Total Volume	10	0	9	19	0	37	50	87	0	2	0	2	3	13	0	16	124
% App. Total	52.6	0	47.4		0	42.5	57.5		0	100	0		18.8	81.2	0		
PHF	.417	.000	.450	.475	.000	.771	.735	.750	.000	.500	.000	.500	.750	.650	.000	.667	.674

0[^ } 0 AM | a a a Q & E
 UU A Q c A F F I
 0 [|] a a Q A G I i
 Q I F D G i E d i

0 a t A - S [] * A ^ a s @
 P B U K C H a a ^ a a U d ^ a ^ a U a a]
 O E Y K A ^ ^] [c ^ a a a O [^] c a a a
 Y ^ a a @ : K A ^ } } ^

0 a ^ A p a a ^ K S O O O S U O T O
 U a a A O [a ^ K E C C C C C E I
 U c a a o O a a K G B J B D E F G
 U a a ^ A p [K G

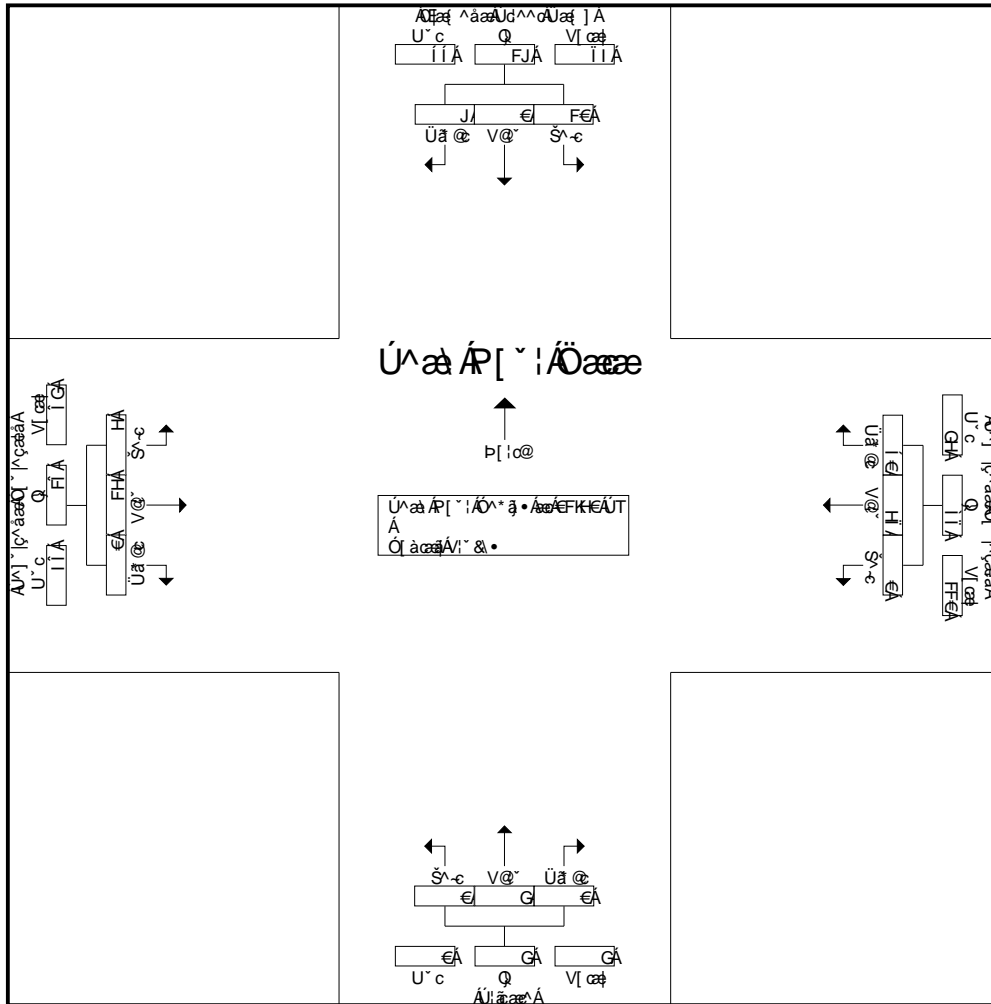

U a a A P [^] A O a a e * a A O [{ A E F K E A U T A E G H I A U T A U U a a A A A - A
 Peak Hour for Each Approach Begins at:

	01:30 PM				01:30 PM				01:30 PM				01:30 PM			
+0 mins.	6	0	4	10	0	12	17	29	0	1	0	1	1	5	0	6
+15 mins.	4	0	5	9	0	8	10	18	0	0	0	0	1	1	0	2
+30 mins.	0	0	0	0	0	9	11	20	0	0	0	0	0	4	0	4
+45 mins.	0	0	0	0	0	8	12	20	0	1	0	1	1	3	0	4
Total Volume	10	0	9	19	0	37	50	87	0	2	0	2	3	13	0	16
% App. Total	52.6	0	47.4		0	42.5	57.5		0	100	0		18.8	81.2	0	
PHF	.417	.000	.450	.475	.000	.771	.735	.750	.000	.500	.000	.500	.750	.650	.000	.667

01:30 PM
 01:45 PM
 02:00 PM
 02:15 PM

01:30 PM
 01:45 PM
 02:00 PM
 02:15 PM

01:30 PM
 01:45 PM
 02:00 PM
 02:15 PM

Groups Printed- Chasis Only Trucks

Start Time	Alameda Street Ramp Southbound				Sepulveda Boulevard Westbound				Private Northbound				Sepulveda Boulevard Eastbound				Int. Total	
	Left	Thru	Right	App. Total	Left	Thru	Right	App. Total	Left	Thru	Right	App. Total	Left	Thru	Right	App. Total		
01:00 PM	0	0	0	0	0	1	0	1	0	0	0	0	0	0	0	0	0	1
01:15 PM	1	0	1	2	0	0	4	4	0	0	0	0	0	0	0	0	0	6
01:30 PM	1	0	0	1	0	1	3	4	0	0	0	0	0	1	0	0	1	6
01:45 PM	1	0	1	2	0	0	5	5	0	0	0	0	0	0	0	0	0	7
Total	3	0	2	5	0	2	12	14	0	0	0	0	0	1	0	0	1	20
02:00 PM	1	0	0	1	0	1	3	4	0	0	0	0	0	0	0	0	0	5
02:15 PM	2	0	1	3	0	0	3	3	0	0	0	0	0	0	0	0	0	6
02:30 PM	1	0	0	1	0	1	2	3	0	0	0	0	0	0	0	0	0	4
02:45 PM	0	0	1	1	0	1	3	4	0	0	0	0	0	0	0	0	0	5
Total	4	0	2	6	0	3	11	14	0	0	0	0	0	0	0	0	0	20
Grand Total	7	0	4	11	0	5	23	28	0	0	0	0	0	1	0	0	1	40
Apprch %	63.6	0	36.4		0	17.9	82.1		0	0	0		0	100	0			
Total %	17.5	0	10	27.5	0	12.5	57.5	70	0	0	0	0	0	2.5	0	2.5		

Start Time	Alameda Street Ramp Southbound				Sepulveda Boulevard Westbound				Private Northbound				Sepulveda Boulevard Eastbound				Int. Total	
	Left	Thru	Right	App. Total	Left	Thru	Right	App. Total	Left	Thru	Right	App. Total	Left	Thru	Right	App. Total		
Peak Hour Analysis From 01:30 PM to 02:15 PM - Peak 1 of 1																		
Peak Hour for Entire Intersection Begins at 01:30 PM																		
01:30 PM	1	0	0	1	0	1	3	4	0	0	0	0	0	1	0	0	1	6
01:45 PM	1	0	1	2	0	0	5	5	0	0	0	0	0	0	0	0	0	7
02:00 PM	1	0	0	1	0	1	3	4	0	0	0	0	0	0	0	0	0	5
02:15 PM	2	0	1	3	0	0	3	3	0	0	0	0	0	0	0	0	0	6
Total Volume	5	0	2	7	0	2	14	16	0	0	0	0	0	1	0	0	1	24
% App. Total	71.4	0	28.6		0	12.5	87.5		0	0	0		0	100	0			
PHF	.625	.000	.500	.583	.000	.500	.700	.800	.000	.000	.000	.000	.000	.250	.000	.250		.857

0[^ } 0 AM | a a a Q & E
 UU A Q c A F I I
 0 [: [] a a 0 0 A G I i
 Q I F D G i E d i

0 a r A - S [] * A ^ a s @
 P B U I K C H a a ^ a a U d ^ a ^ a U a a]
 O E Y K A ^ ^] [c ^ a a a 0 [^] c a a a
 Y ^ a a @ : K A ^ } } ^

0 a r A a a ^ K S O O O S U O T O
 U a a A O [a ^ K E E E E E E I
 U c a a 0 0 a a K G B J B D E F G
 U a a ^ A r [K G

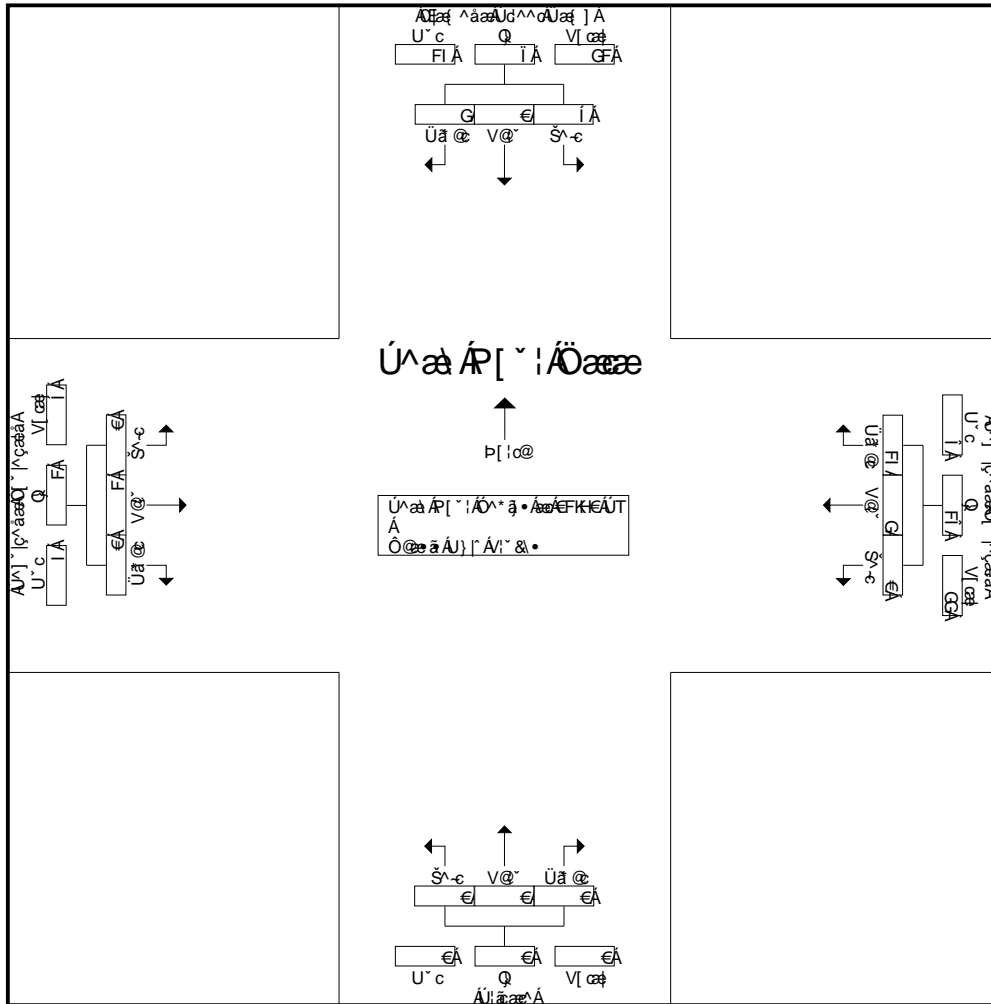

U^aa AP[^ | A O a a e • a A O [{ A E F K E A U T A E G H I A U T A E U ^ a a A E A - A
 Peak Hour for Each Approach Begins at:

	01:30 PM				01:30 PM				01:30 PM				01:30 PM			
+0 mins.	1	0	0	1	0	1	3	4	0	0	0	0	0	1	0	1
+15 mins.	1	0	1	2	0	0	5	5	0	0	0	0	0	0	0	0
+30 mins.	1	0	0	1	0	1	3	4	0	0	0	0	0	0	0	0
+45 mins.	2	0	1	3	0	0	3	3	0	0	0	0	0	0	0	0
Total Volume	5	0	2	7	0	2	14	16	0	0	0	0	0	1	0	1
% App. Total	71.4	0	28.6		0	12.5	87.5		0	0	0		0	100	0	
PHF	.625	.000	.500	.583	.000	.500	.700	.800	.000	.000	.000	.000	.000	.250	.000	.250

01:30 PM
 01:45 PM
 02:00 PM
 02:15 PM

01:30 PM
 01:45 PM
 02:00 PM
 02:15 PM

01:30 PM
 01:45 PM
 02:00 PM
 02:15 PM

Groups Printed- Container Trucks

Start Time	Alameda Street Ramp Southbound				Sepulveda Boulevard Westbound				Private Northbound				Sepulveda Boulevard Eastbound				Int. Total
	Left	Thru	Right	App. Total	Left	Thru	Right	App. Total	Left	Thru	Right	App. Total	Left	Thru	Right	App. Total	
01:00 PM	7	0	3	10	0	0	5	5	0	0	0	0	0	5	0	5	20
01:15 PM	10	0	1	11	0	3	3	6	0	0	0	0	3	9	0	12	29
01:30 PM	6	0	4	10	0	3	4	7	0	0	0	0	3	8	0	11	28
01:45 PM	11	0	3	14	0	5	3	8	0	0	0	0	2	6	0	8	30
Total	34	0	11	45	0	11	15	26	0	0	0	0	8	28	0	36	107
02:00 PM	0	0	0	0	0	0	0	0	0	0	0	0	0	0	0	0	0
02:15 PM	0	0	0	0	0	0	0	0	0	0	0	0	0	0	0	0	0
02:30 PM	0	0	0	0	0	0	0	0	0	0	0	0	0	0	0	0	0
02:45 PM	0	0	0	0	0	0	0	0	0	0	0	0	0	0	0	0	0
Total	0	0	0	0	0	0	0	0	0	0	0	0	0	0	0	0	0
Grand Total	34	0	11	45	0	11	15	26	0	0	0	0	8	28	0	36	107
Apprch %	75.6	0	24.4		0	42.3	57.7		0	0	0		22.2	77.8	0		
Total %	31.8	0	10.3	42.1	0	10.3	14	24.3	0	0	0	0	7.5	26.2	0	33.6	

Start Time	Alameda Street Ramp Southbound				Sepulveda Boulevard Westbound				Private Northbound				Sepulveda Boulevard Eastbound				Int. Total
	Left	Thru	Right	App. Total	Left	Thru	Right	App. Total	Left	Thru	Right	App. Total	Left	Thru	Right	App. Total	
Peak Hour Analysis From 01:30 PM to 02:15 PM - Peak 1 of 1																	
Peak Hour for Entire Intersection Begins at 01:30 PM																	
01:30 PM	6	0	4	10	0	3	4	7	0	0	0	0	3	8	0	11	28
01:45 PM	11	0	3	14	0	5	3	8	0	0	0	0	2	6	0	8	30
02:00 PM	0	0	0	0	0	0	0	0	0	0	0	0	0	0	0	0	0
02:15 PM	0	0	0	0	0	0	0	0	0	0	0	0	0	0	0	0	0
Total Volume	17	0	7	24	0	8	7	15	0	0	0	0	5	14	0	19	58
% App. Total	70.8	0	29.2		0	53.3	46.7		0	0	0		26.3	73.7	0		
PHF	.386	.000	.438	.429	.000	.400	.438	.469	.000	.000	.000	.000	.417	.438	.000	.432	.483

0[^ } . 0 AM | a a a Q & E
 UU A Q c A F I I
 0[| | } a a 0 A G I i
 Q I F D G i E d i

0 a r A - S [] * A ^ a s @
 P B U I K C H a a ^ a a U d ^ a c U a a]
 O E Y K A ^ ^] [c ^ a a a 0 [^ c a a a
 Y ^ a a @ : K A ^ } } ^

0 a ^ A p a a ^ K S O O O S U O T O
 U a a A O [a ^ K E E E E E E I
 U c a a 0 A a a K G B J B D E F G
 U a a ^ A p [K G

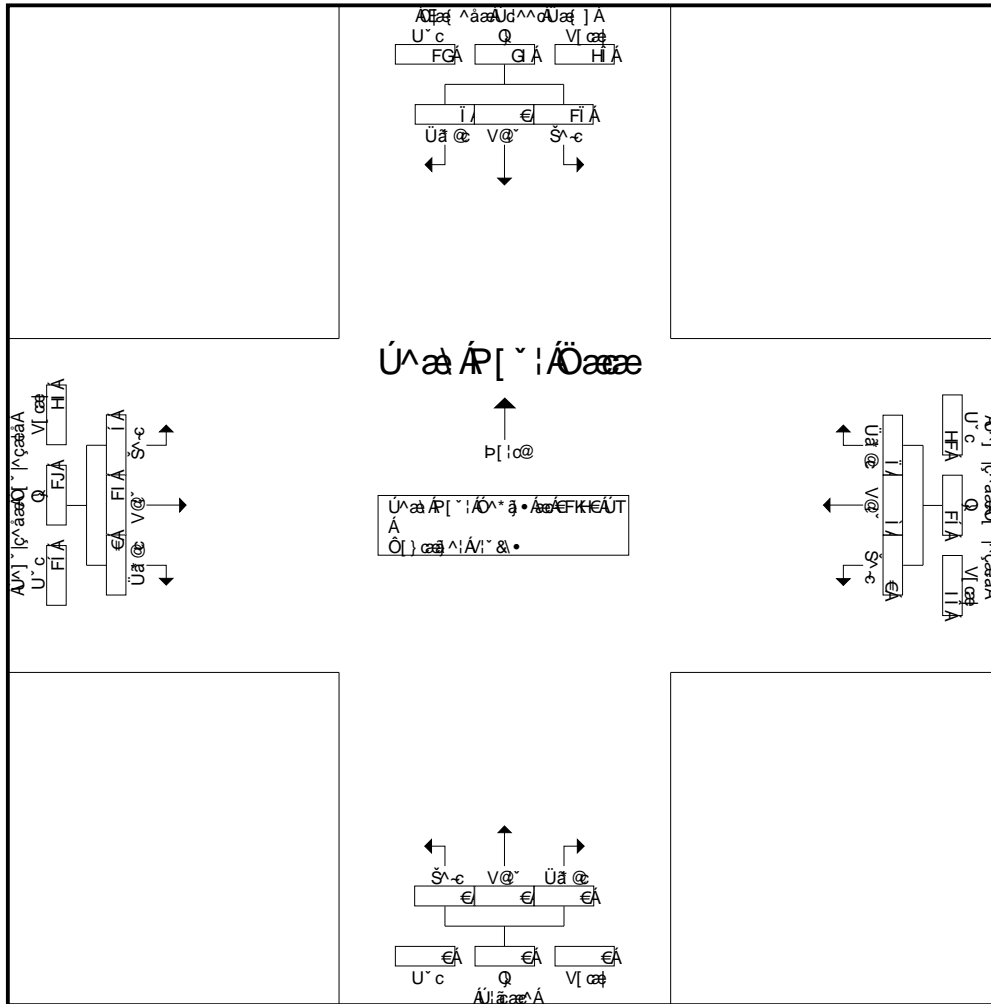

U^ a a A P [^ | A O a a e a A O [{ A E F K E A U T A E G H I A U T A E U ^ a a A E A A - A
 Peak Hour for Each Approach Begins at:

	01:30 PM				01:30 PM				01:30 PM				01:30 PM			
+0 mins.	6	0	4	10	0	3	4	7	0	0	0	0	3	8	0	11
+15 mins.	11	0	3	14	0	5	3	8	0	0	0	0	2	6	0	8
+30 mins.	0	0	0	0	0	0	0	0	0	0	0	0	0	0	0	0
+45 mins.	0	0	0	0	0	0	0	0	0	0	0	0	0	0	0	0
Total Volume	17	0	7	24	0	8	7	15	0	0	0	0	5	14	0	19
% App. Total	70.8	0	29.2		0	53.3	46.7		0	0	0		26.3	73.7	0	
PHF	.386	.000	.438	.429	.000	.400	.438	.469	.000	.000	.000	.000	.417	.438	.000	.432

01:30 PM
 01:45 PM
 02:00 PM
 02:15 PM

01:30 PM
 01:45 PM
 02:00 PM
 02:15 PM

01:30 PM
 01:45 PM
 02:00 PM
 02:15 PM

Groups Printed- Other trucks

Start Time	Alameda Street Ramp Southbound				Sepulveda Boulevard Westbound				Private Northbound				Sepulveda Boulevard Eastbound				Int. Total
	Left	Thru	Right	App. Total	Left	Thru	Right	App. Total	Left	Thru	Right	App. Total	Left	Thru	Right	App. Total	
01:00 PM	2	1	5	8	0	1	4	5	0	3	0	3	0	3	1	4	20
01:15 PM	4	3	1	8	0	4	3	7	1	2	0	3	2	3	0	5	23
01:30 PM	5	2	3	10	0	4	1	5	0	1	0	1	0	7	0	7	23
01:45 PM	3	2	1	6	1	4	6	11	1	3	0	4	0	2	0	2	23
Total	14	8	10	32	1	13	14	28	2	9	0	11	2	15	1	18	89
02:00 PM	0	0	0	0	0	0	0	0	0	0	0	0	0	0	0	0	0
02:15 PM	0	0	0	0	0	0	0	0	0	0	0	0	0	0	0	0	0
02:30 PM	0	0	0	0	0	0	0	0	0	0	0	0	0	0	0	0	0
02:45 PM	0	0	0	0	0	0	0	0	0	0	0	0	0	0	0	0	0
Total	0	0	0	0	0	0	0	0	0	0	0	0	0	0	0	0	0
Grand Total	14	8	10	32	1	13	14	28	2	9	0	11	2	15	1	18	89
Apprch %	43.8	25	31.2		3.6	46.4	50		18.2	81.8	0		11.1	83.3	5.6		
Total %	15.7	9	11.2	36	1.1	14.6	15.7	31.5	2.2	10.1	0	12.4	2.2	16.9	1.1	20.2	

Start Time	Alameda Street Ramp Southbound				Sepulveda Boulevard Westbound				Private Northbound				Sepulveda Boulevard Eastbound				Int. Total
	Left	Thru	Right	App. Total	Left	Thru	Right	App. Total	Left	Thru	Right	App. Total	Left	Thru	Right	App. Total	
01:30 PM	5	2	3	10	0	4	1	5	0	1	0	1	0	7	0	7	23
01:45 PM	3	2	1	6	1	4	6	11	1	3	0	4	0	2	0	2	23
02:00 PM	0	0	0	0	0	0	0	0	0	0	0	0	0	0	0	0	0
02:15 PM	0	0	0	0	0	0	0	0	0	0	0	0	0	0	0	0	0
Total Volume	8	4	4	16	1	8	7	16	1	4	0	5	0	9	0	9	46
% App. Total	50	25	25		6.2	50	43.8		20	80	0		0	100	0		
PHF	.400	.500	.333	.400	.250	.500	.292	.364	.250	.333	.000	.313	.000	.321	.000	.321	.500

Peak Hour Analysis From 01:30 PM to 02:15 PM - Peak 1 of 1

Peak Hour for Entire Intersection Begins at 01:30 PM

0[^ } , o AM | a a a Q & E
 UU A O | c A F I I
 O [: |] } a a O A G I i
 Q I F D G i E d i

O a r A - S [] * A O a s @
 P B U I K O C H a a a U d ^ ^ o U a a]
 O E Y K A U ^] [c ^ a a a O [^ c a a a
 Y ^ a a @ : K A U } } ^

O a r A a a ^ K S O O O S U O T O
 U a a A O | a ^ K E C C C C C E I I
 U c a a o O a a ^ K G B J B D E F G
 U a a ^ A r [K G

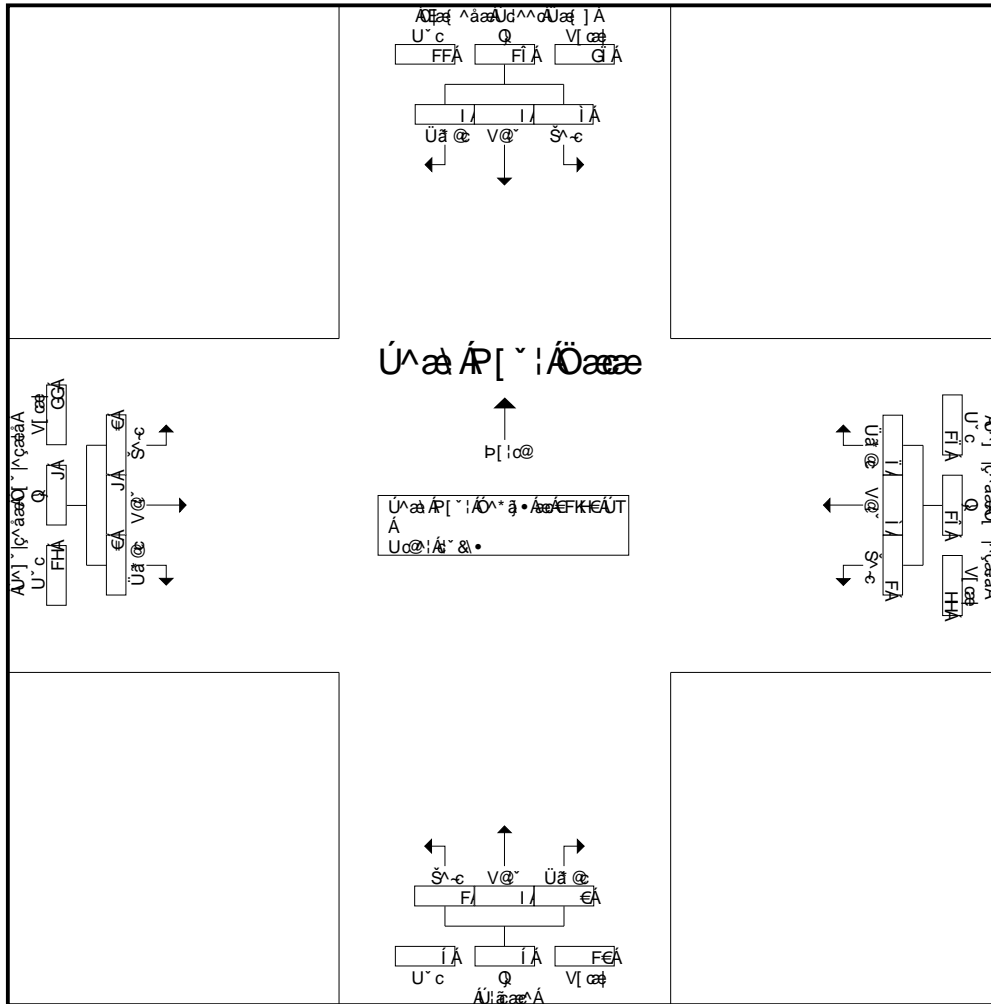

U a a A r [^ | A O a a e } a A O [{ A E F I K E A U T A E G H I A U T A A U a a A r A - A
 Peak Hour for Each Approach Begins at:

	01:30 PM				01:30 PM				01:30 PM				01:30 PM			
+0 mins.	5	2	3	10	0	4	1	5	0	1	0	1	0	7	0	7
+15 mins.	3	2	1	6	1	4	6	11	1	3	0	4	0	2	0	2
+30 mins.	0	0	0	0	0	0	0	0	0	0	0	0	0	0	0	0
+45 mins.	0	0	0	0	0	0	0	0	0	0	0	0	0	0	0	0
Total Volume	8	4	4	16	1	8	7	16	1	4	0	5	0	9	0	9
% App. Total	50	25	25		6.2	50	43.8		20	80	0		0	100	0	
PHF	.400	.500	.333	.400	.250	.500	.292	.364	.250	.333	.000	.313	.000	.321	.000	.321

01 ~ } o ÁM |ã ã á ÁQ&E
 UUÁO cÁFI I
 ÔI () aÉOÖÁG I i
 QI FDG i È G I

Ôã Á -S() * Á^ã@
 PDUKÇã ããÁÜd^ÁÜã]
 ÖY KÁ] ~ |c^ããÔ ~ |cãã
 Y ^ã@:KÁ } } ^

Ôã Áã ^ KÖÖÖSÜÖT
 Üã ÁO ã^ KÉÉÉÉÉ I
 Üã ÖÖã KÇBWBFG
 Üã ÁP | Kã

Groups Printed- Passenger Vehicles - Bobtail Trucks - Chasis Only Trucks - Container Trucks - Other Trucks

Start Time	Alameda Street Ramp Southbound				Sepulveda Boulevard Westbound				Private Northbound				Sepulveda Boulevard Eastbound				Int. Total
	Left	Thru	Right	App. Total	Left	Thru	Right	App. Total	Left	Thru	Right	App. Total	Left	Thru	Right	App. Total	
04:00 PM	20	3	30	53	4	91	65	160	2	11	0	13	44	182	3	229	455
04:15 PM	25	2	30	57	2	103	78	183	1	6	8	15	35	176	0	211	466
04:30 PM	34	1	37	72	1	107	83	191	1	8	6	15	52	183	0	235	513
04:45 PM	38	6	36	80	0	87	59	146	1	5	1	7	43	195	1	239	472
Total	117	12	133	262	7	388	285	680	5	30	15	50	174	736	4	914	1906
05:00 PM	28	5	38	71	1	107	65	173	1	0	0	1	30	248	0	278	523
05:15 PM	34	2	33	69	0	99	30	129	1	4	0	5	39	206	1	246	449
05:30 PM	21	1	14	36	0	91	26	117	2	5	0	7	40	179	1	220	380
05:45 PM	25	2	20	47	1	100	30	131	0	5	1	6	24	172	0	196	380
Total	108	10	105	223	2	397	151	550	4	14	1	19	133	805	2	940	1732
Grand Total	225	22	238	485	9	785	436	1230	9	44	16	69	307	1541	6	1854	3638
Apprch %	46.4	4.5	49.1		0.7	63.8	35.4		13	63.8	23.2		16.6	83.1	0.3		
Total %	6.2	0.6	6.5	13.3	0.2	21.6	12	33.8	0.2	1.2	0.4	1.9	8.4	42.4	0.2	51	
Passenger Vehicles	150	2	184	336	6	710	228	944	9	19	16	44	248	1348	4	1600	2924
% Passenger Vehicles	66.7	9.1	77.3	69.3	66.7	90.4	52.3	76.7	100	43.2	100	63.8	80.8	87.5	66.7	86.3	80.4
Bobtail Trucks	38	0	35	73	0	42	135	177	0	0	0	0	12	110	0	122	372
% Bobtail Trucks	16.9	0	14.7	15.1	0	5.4	31	14.4	0	0	0	0	3.9	7.1	0	6.6	10.2
Chasis Only Trucks	3	0	2	5	0	0	4	4	0	0	0	0	1	7	0	8	17
% Chasis Only Trucks	1.3	0	0.8	1	0	0	0.9	0.3	0	0	0	0	0.3	0.5	0	0.4	0.5
Container Trucks	26	0	10	36	0	26	50	76	0	0	0	0	32	63	0	95	207
% Container Trucks	11.6	0	4.2	7.4	0	3.3	11.5	6.2	0	0	0	0	10.4	4.1	0	5.1	5.7
Other Trucks	8	20	7	35	3	7	19	29	0	25	0	25	14	13	2	29	118
% Other Trucks	3.6	90.9	2.9	7.2	33.3	0.9	4.4	2.4	0	56.8	0	36.2	4.6	0.8	33.3	1.6	3.2

Start Time	Alameda Street Ramp Southbound				Sepulveda Boulevard Westbound				Private Northbound				Sepulveda Boulevard Eastbound				Int. Total
	Left	Thru	Right	App. Total	Left	Thru	Right	App. Total	Left	Thru	Right	App. Total	Left	Thru	Right	App. Total	
04:15 PM	25	2	30	57	2	103	78	183	1	6	8	15	35	176	0	211	466
04:30 PM	34	1	37	72	1	107	83	191	1	8	6	15	52	183	0	235	513
04:45 PM	38	6	36	80	0	87	59	146	1	5	1	7	43	195	1	239	472
05:00 PM	28	5	38	71	1	107	65	173	1	0	0	1	30	248	0	278	523
Total Volume	125	14	141	280	4	404	285	693	4	19	15	38	160	802	1	963	1974
% App. Total	44.6	5	50.4		0.6	58.3	41.1		10.5	50	39.5		16.6	83.3	0.1		
PHF	.822	.583	.928	.875	.500	.944	.858	.907	1.00	.594	.469	.633	.769	.808	.250	.866	.944

Peak Hour Analysis From 04:15 PM to 05:00 PM - Peak 1 of 1

Peak Hour for Entire Intersection Begins at 04:15 PM

Ô[~ } , Ô ÁM | ä ä ä Ä Q & E
 UU Ä Ö c Ä F I I
 Ô [! |] ä ä Ö Ä G I I
 Q I F D G I E G I

Ô ä Ä - Ä [] * Ä ^ ä ä @
 P B U I K O Ä ä ä ä Ä U d ^ Ä Ä U ä ä]
 Ö E Y K Ä ^ ^ [ç ^ ä ä Ä Ö [^ ç ä ä ä
 Y ^ ä ä @ : K Ä ^ } } ^

Ô Ä Ä ä ä ^ K S Ö Ö C S U Ö U T
 U ä ä Ä Ö [ä ä ^ K E C C C C C I
 U ä ä c Ö ä ä ^ K C B U B D E F G
 U ä ä ^ Ä [K G

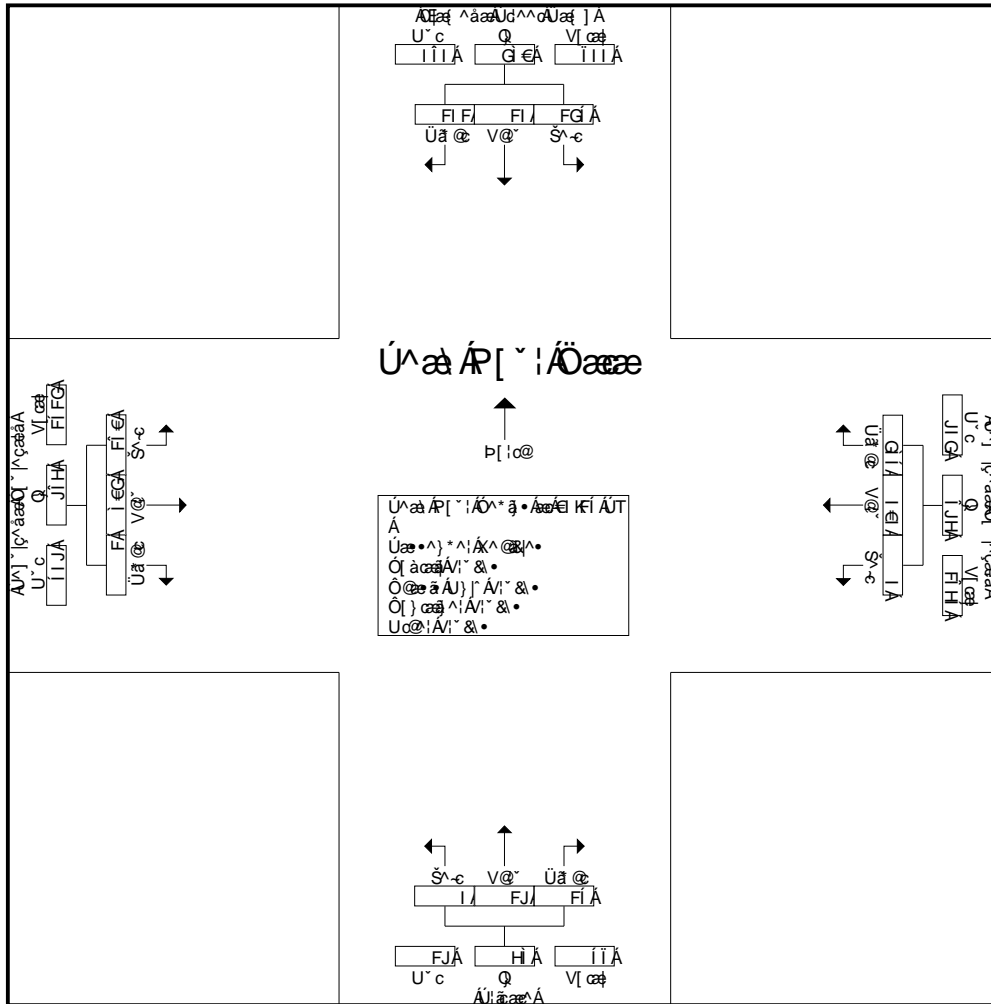

U ä ä Ä R [~ ! Ä Ö ä ä ä • ä ä Ä [{ Ä I K F I Ä U T Ä Ä I K E Ä U T Ä Ä U ä ä Ä Ä Ä - Ä
 Peak Hour for Each Approach Begins at:

	04:15 PM				04:15 PM				04:15 PM				04:15 PM			
+0 mins.	25	2	30	57	2	103	78	183	1	6	8	15	35	176	0	211
+15 mins.	34	1	37	72	1	107	83	191	1	8	6	15	52	183	0	235
+30 mins.	38	6	36	80	0	87	59	146	1	5	1	7	43	195	1	239
+45 mins.	28	5	38	71	1	107	65	173	1	0	0	1	30	248	0	278
Total Volume	125	14	141	280	4	404	285	693	4	19	15	38	160	802	1	963
% App. Total	44.6	5	50.4		0.6	58.3	41.1		10.5	50	39.5		16.6	83.3	0.1	
PHF	.822	.583	.928	.875	.500	.944	.858	.907	1.000	.594	.469	.633	.769	.808	.250	.866

0[~ } o ÁM |ã ä á ÁQ&É
 UUÁOj cÁFI I
 ÔI() äZOOÁG I i
 QI FDG i È G I

Ôä Á -S() * Á^æ@
 PDUKÇä äääÜd^^Üä]
 ÖY KÜ^] c^ääÖ] ^çää
 Y ^æ@:KÜ } } ^

ÔÄ Á ç ^ KÖÖÖSÜÖT
 Üä ÁÖ ä^ KÉÉÉÉÉ I
 ÜääÖÖä KÇJ BDFG
 Üä ^ Á [KÄ

Groups Printed- Passenger Vehicles

Start Time	Alameda Street Ramp Southbound				Sepulveda Boulevard Westbound				Private Northbound				Sepulveda Boulevard Eastbound				Int. Total
	Left	Thru	Right	App. Total	Left	Thru	Right	App. Total	Left	Thru	Right	App. Total	Left	Thru	Right	App. Total	
04:00 PM	13	0	18	31	2	66	28	96	2	5	0	7	34	144	1	179	313
04:15 PM	13	0	20	33	1	88	34	123	1	5	8	14	31	154	0	185	355
04:30 PM	25	0	31	56	1	94	45	140	1	7	6	14	45	151	0	196	406
04:45 PM	24	0	25	49	0	77	24	101	1	0	1	2	31	176	1	208	360
Total	75	0	94	169	4	325	131	460	5	17	15	37	141	625	2	768	1434
05:00 PM	17	1	31	49	1	106	45	152	1	0	0	1	22	214	0	236	438
05:15 PM	22	1	28	51	0	96	19	115	1	0	0	1	31	186	1	218	385
05:30 PM	15	0	11	26	0	89	15	104	2	2	0	4	35	159	1	195	329
05:45 PM	21	0	20	41	1	94	18	113	0	0	1	1	19	164	0	183	338
Total	75	2	90	167	2	385	97	484	4	2	1	7	107	723	2	832	1490
Grand Total	150	2	184	336	6	710	228	944	9	19	16	44	248	1348	4	1600	2924
Apprch %	44.6	0.6	54.8		0.6	75.2	24.2		20.5	43.2	36.4		15.5	84.2	0.2		
Total %	5.1	0.1	6.3	11.5	0.2	24.3	7.8	32.3	0.3	0.6	0.5	1.5	8.5	46.1	0.1	54.7	

Start Time	Alameda Street Ramp Southbound				Sepulveda Boulevard Westbound				Private Northbound				Sepulveda Boulevard Eastbound				Int. Total
	Left	Thru	Right	App. Total	Left	Thru	Right	App. Total	Left	Thru	Right	App. Total	Left	Thru	Right	App. Total	
Peak Hour Analysis From 04:15 PM to 05:00 PM - Peak 1 of 1																	
Peak Hour for Entire Intersection Begins at 04:15 PM																	
04:15 PM	13	0	20	33	1	88	34	123	1	5	8	14	31	154	0	185	355
04:30 PM	25	0	31	56	1	94	45	140	1	7	6	14	45	151	0	196	406
04:45 PM	24	0	25	49	0	77	24	101	1	0	1	2	31	176	1	208	360
05:00 PM	17	1	31	49	1	106	45	152	1	0	0	1	22	214	0	236	438
Total Volume	79	1	107	187	3	365	148	516	4	12	15	31	129	695	1	825	1559
% App. Total	42.2	0.5	57.2		0.6	70.7	28.7		12.9	38.7	48.4		15.6	84.2	0.1		
PHF	.790	.250	.863	.835	.750	.861	.822	.849	1.00	.429	.469	.554	.717	.812	.250	.874	.890

0[~ } 0 AM |ã äããQ&E
 UUÄJ cÄFFII
 Ö[!:] äãÖÖÄGii
 QI FÄG i E ä i

Öã Ä -Ä[] * Ä^ã&@
 ÞEÜKÖEä äããÄd^ãÄÜä]
 ÖEY KÄ^~ |ç^ããÖ[^çãää
 Y ^ã&@:KÄ^}}^

Ö^ Äã ^ KÖÖÖÖSÜÖÜT
 Üã ÄÖ[ä^ KÉÉÉÉÉÉ i
 ÜããÖãä KÖGJ BDFG
 Üã ^ Ä[KÖG

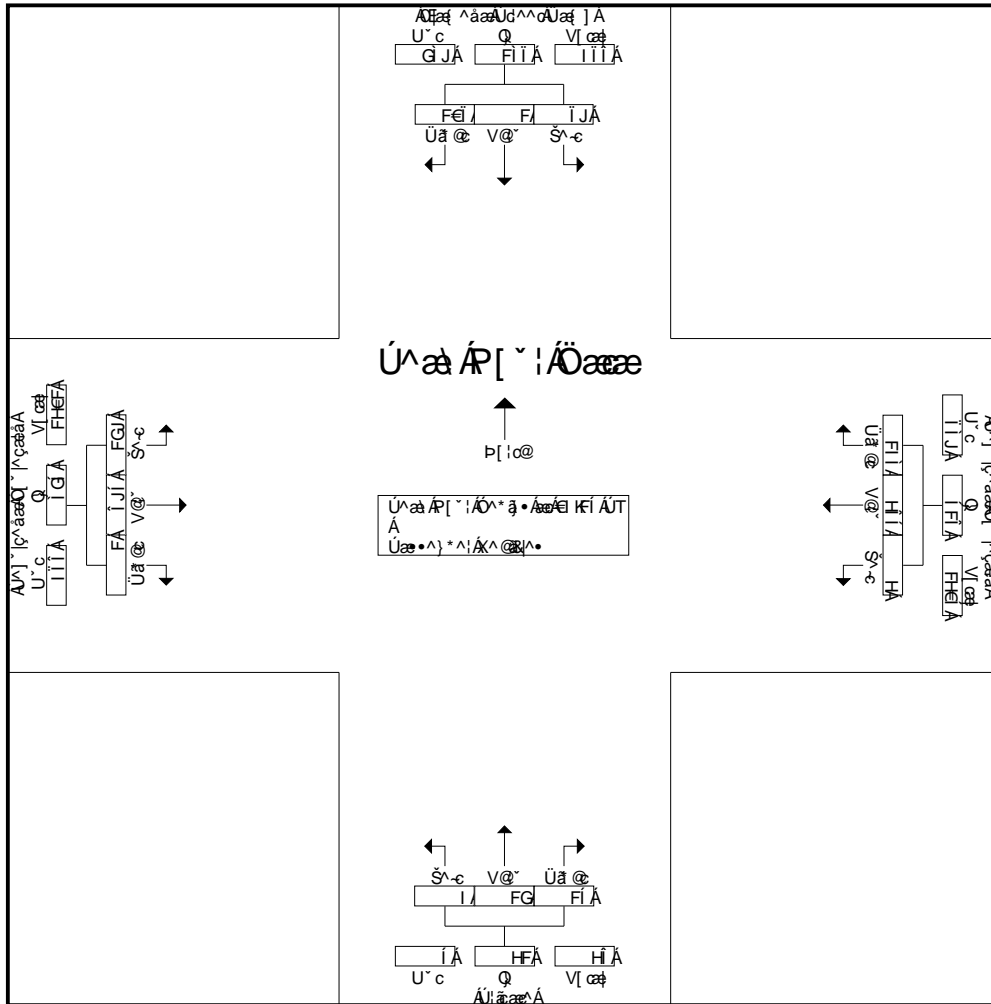

Üã ä Ä[~ | ÄÖäææ • ä ÄÖ[{ ÄE KFI ÄÜT ÄE ÄE KÉÄÜT ÄÄÜã ä ÄÄ -Ä
 Peak Hour for Each Approach Begins at:

	04:15 PM				04:15 PM				04:15 PM				04:15 PM			
+0 mins.	13	0	20	33	1	88	34	123	1	5	8	14	31	154	0	185
+15 mins.	25	0	31	56	1	94	45	140	1	7	6	14	45	151	0	196
+30 mins.	24	0	25	49	0	77	24	101	1	0	1	2	31	176	1	208
+45 mins.	17	1	31	49	1	106	45	152	1	0	0	1	22	214	0	236
Total Volume	79	1	107	187	3	365	148	516	4	12	15	31	129	695	1	825
% App. Total	42.2	0.5	57.2		0.6	70.7	28.7		12.9	38.7	48.4		15.6	84.2	0.1	
PHF	.790	.250	.863	.835	.750	.861	.822	.849	1.000	.429	.469	.554	.717	.812	.250	.874

01 ~ } o ÁM |ã à^áQ&É
 UUÁO cÁFI I
 ÔI() aZOOÁG I i
 QI FDG i È G i

Ôã Á -S() * Á^as@
 PDUKChã ^ããUd^ãUã]
 OBY KÁU] ^c^ããO] ^cãã
 Y ^ãã@:KÁ } } ^

Qã Áã ^ K\$OOCSÙÓUT
 Úã ÁO] á^ KÉÉÉÉÉ I
 ÚããOãã KCBJDEFG
 Úã ^Á] KÁ

Groups Printed- Bobtail Trucks

Start Time	Alameda Street Ramp Southbound				Sepulveda Boulevard Westbound				Private Northbound				Sepulveda Boulevard Eastbound				Int. Total
	Left	Thru	Right	App. Total	Left	Thru	Right	App. Total	Left	Thru	Right	App. Total	Left	Thru	Right	App. Total	
04:00 PM	4	0	9	13	0	12	25	37	0	0	0	0	4	20	0	24	74
04:15 PM	4	0	5	9	0	13	32	45	0	0	0	0	1	13	0	14	68
04:30 PM	5	0	4	9	0	4	27	31	0	0	0	0	1	16	0	17	57
04:45 PM	8	0	6	14	0	8	21	29	0	0	0	0	1	10	0	11	54
Total	21	0	24	45	0	37	105	142	0	0	0	0	7	59	0	66	253
05:00 PM	6	0	5	11	0	1	12	13	0	0	0	0	2	22	0	24	48
05:15 PM	4	0	5	9	0	2	5	7	0	0	0	0	1	10	0	11	27
05:30 PM	3	0	1	4	0	1	9	10	0	0	0	0	2	13	0	15	29
05:45 PM	4	0	0	4	0	1	4	5	0	0	0	0	0	6	0	6	15
Total	17	0	11	28	0	5	30	35	0	0	0	0	5	51	0	56	119
Grand Total	38	0	35	73	0	42	135	177	0	0	0	0	12	110	0	122	372
Apprch %	52.1	0	47.9		0	23.7	76.3		0	0	0		9.8	90.2	0		
Total %	10.2	0	9.4	19.6	0	11.3	36.3	47.6	0	0	0	0	3.2	29.6	0	32.8	

Start Time	Alameda Street Ramp Southbound				Sepulveda Boulevard Westbound				Private Northbound				Sepulveda Boulevard Eastbound				Int. Total
	Left	Thru	Right	App. Total	Left	Thru	Right	App. Total	Left	Thru	Right	App. Total	Left	Thru	Right	App. Total	
04:15 PM	4	0	5	9	0	13	32	45	0	0	0	0	1	13	0	14	68
04:30 PM	5	0	4	9	0	4	27	31	0	0	0	0	1	16	0	17	57
04:45 PM	8	0	6	14	0	8	21	29	0	0	0	0	1	10	0	11	54
05:00 PM	6	0	5	11	0	1	12	13	0	0	0	0	2	22	0	24	48
Total Volume	23	0	20	43	0	26	92	118	0	0	0	0	5	61	0	66	227
% App. Total	53.5	0	46.5		0	22	78		0	0	0		7.6	92.4	0		
PHF	.719	.000	.833	.768	.000	.500	.719	.656	.000	.000	.000	.000	.625	.693	.000	.688	.835

Peak Hour Analysis From 04:15 PM to 05:00 PM - Peak 1 of 1

Peak Hour for Entire Intersection Begins at 04:15 PM

0[^ } , o AM | a , a a Q & E
 UU A Q c A F F I I
 0 [: |] a a Q A G I i
 Q I F D G i E G i

0 a r A - S [] * A O ^ a a @
 P B U I K O C H a a ^ a a U d ^ ^ c U a a]
 O E Y K A U ^] [c ^ a a a O ^] ^ c a a a
 Y ^ a a @ : K A U } } ^

0 a r A a a ^ K S O O C S U O U T
 U a a A O] a ^ K E C C C C C E I
 U c a a c O a a K C B J B D E F G
 U a a ^ A r K G

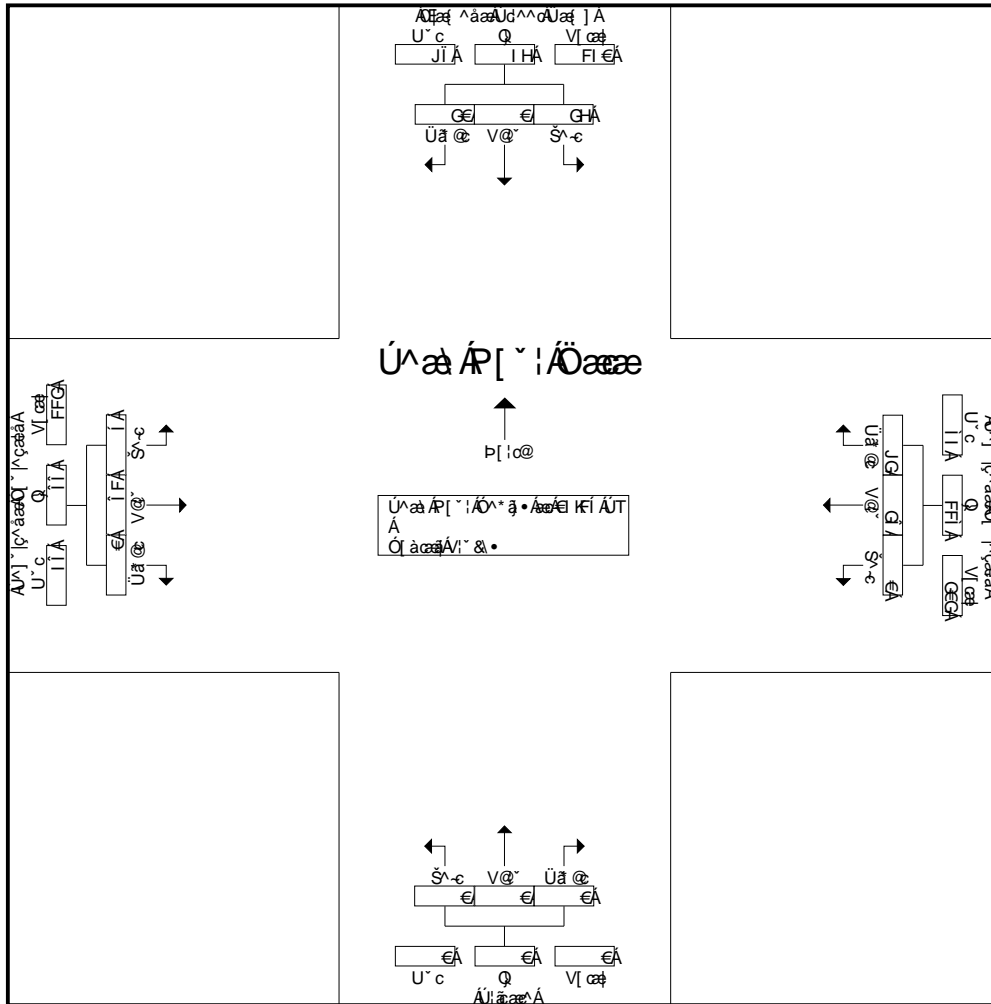

U a a A R [^] A O a a e . A a a K I A U T A e A i K E A U T A U U a a A r A - A
 Peak Hour for Each Approach Begins at:

	04:15 PM				04:15 PM				04:15 PM				04:15 PM			
+0 mins.	4	0	5	9	0	13	32	45	0	0	0	0	1	13	0	14
+15 mins.	5	0	4	9	0	4	27	31	0	0	0	0	1	16	0	17
+30 mins.	8	0	6	14	0	8	21	29	0	0	0	0	1	10	0	11
+45 mins.	6	0	5	11	0	1	12	13	0	0	0	0	2	22	0	24
Total Volume	23	0	20	43	0	26	92	118	0	0	0	0	5	61	0	66
% App. Total	53.5	0	46.5		0	22	78		0	0	0		7.6	92.4	0	
PHF	.719	.000	.833	.768	.000	.500	.719	.656	.000	.000	.000	.000	.625	.693	.000	.688

01 } 0 AM | a a a Q & E
 UU A O c A F I I
 O I () a 0 0 A G I I
 Q I F D G i E G I

O a A - S () * A ^ a s @
 P B U K O C a a ^ a a U d ^ a ^ U a a]
 O E Y K A U ^ (c ^ a a a O ^ (c a a a
 Y ^ a a @ (K U ^) } ^

O a A a a ^ K S O O C S U O U T
 U a e A O i a ^ K E C C C C C I
 U a e o O a a ^ K C B U B D E F G
 U a e ^ A p [K F

Groups Printed- Chasis Only Trucks

Start Time	Alameda Street Ramp Southbound				Sepulveda Boulevard Westbound				Private Northbound				Sepulveda Boulevard Eastbound				Int. Total
	Left	Thru	Right	App. Total	Left	Thru	Right	App. Total	Left	Thru	Right	App. Total	Left	Thru	Right	App. Total	
04:00 PM	0	0	0	0	0	0	0	0	0	0	0	0	1	0	0	1	1
04:15 PM	0	0	2	2	0	0	0	0	0	0	0	0	0	3	0	3	5
04:30 PM	2	0	0	2	0	0	0	0	0	0	0	0	0	1	0	1	3
04:45 PM	0	0	0	0	0	0	1	1	0	0	0	0	0	0	0	0	1
Total	2	0	2	4	0	0	1	1	0	0	0	0	1	4	0	5	10
05:00 PM	0	0	0	0	0	0	0	0	0	0	0	0	0	1	0	1	1
05:15 PM	0	0	0	0	0	0	1	1	0	0	0	0	0	1	0	1	2
05:30 PM	1	0	0	1	0	0	0	0	0	0	0	0	0	1	0	1	2
05:45 PM	0	0	0	0	0	0	2	2	0	0	0	0	0	0	0	0	2
Total	1	0	0	1	0	0	3	3	0	0	0	0	0	3	0	3	7
Grand Total	3	0	2	5	0	0	4	4	0	0	0	0	1	7	0	8	17
Apprch %	60	0	40		0	0	100		0	0	0		12.5	87.5	0		
Total %	17.6	0	11.8	29.4	0	0	23.5	23.5	0	0	0	0	5.9	41.2	0	47.1	

Start Time	Alameda Street Ramp Southbound				Sepulveda Boulevard Westbound				Private Northbound				Sepulveda Boulevard Eastbound				Int. Total
	Left	Thru	Right	App. Total	Left	Thru	Right	App. Total	Left	Thru	Right	App. Total	Left	Thru	Right	App. Total	
04:15 PM	0	0	2	2	0	0	0	0	0	0	0	0	0	3	0	3	5
04:30 PM	2	0	0	2	0	0	0	0	0	0	0	0	0	1	0	1	3
04:45 PM	0	0	0	0	0	0	1	1	0	0	0	0	0	0	0	0	1
05:00 PM	0	0	0	0	0	0	0	0	0	0	0	0	0	1	0	1	1
Total Volume	2	0	2	4	0	0	1	1	0	0	0	0	0	5	0	5	10
% App. Total	50	0	50		0	0	100		0	0	0		0	100	0		
PHF	.250	.000	.250	.500	.000	.000	.250	.250	.000	.000	.000	.000	.000	.417	.000	.417	.500

Peak Hour Analysis From 04:15 PM to 05:00 PM - Peak 1 of 1

Peak Hour for Entire Intersection Begins at 04:15 PM

0[] 0 AM | a a a Q & E
 UU A Q c A F I I
 0[] | } a a Q A G I I
 Q I F D G I E G I

0 a A - S [] * A ^ a a @
 P B U K C H a a ^ a a U d ^ a ^ a U a a]
 O E Y K A ^] ^ [c ^ a a Q [^] c a a a
 Y ^ a a @ : K A ^ } } ^

0 a A a a ^ K S O O C S U O U T
 U a a A Q] a ^ K E C C C C E I
 U c a a 0 a a ^ K C B U B D E F G
 U a a ^ A [K G

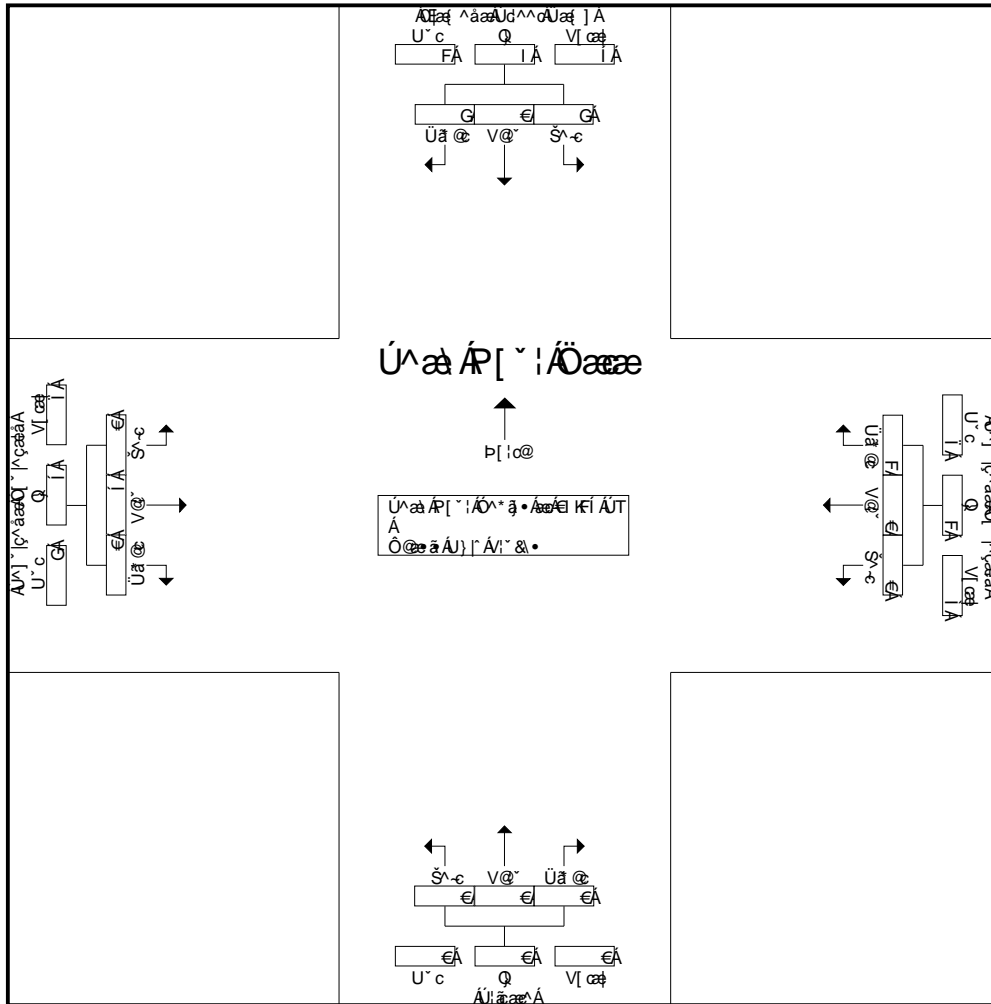

U a a A R [^] A O a a e * a a a [{ A E K F I A U T A E A I K E A U T A U U a a A A A - A
 Peak Hour for Each Approach Begins at:

	04:15 PM				04:15 PM				04:15 PM				04:15 PM			
+0 mins.	0	0	2	2	0	0	0	0	0	0	0	0	0	3	0	3
+15 mins.	2	0	0	2	0	0	0	0	0	0	0	0	0	1	0	1
+30 mins.	0	0	0	0	0	0	1	1	0	0	0	0	0	0	0	0
+45 mins.	0	0	0	0	0	0	0	0	0	0	0	0	0	1	0	1
Total Volume	2	0	2	4	0	0	1	1	0	0	0	0	0	5	0	5
% App. Total	50	0	50		0	0	100		0	0	0		0	100	0	
PHF	.250	.000	.250	.500	.000	.000	.250	.250	.000	.000	.000	.000	.000	.417	.000	.417

01 } 0 AM | a a a Q & E
 UU O c A F I
 O I () a 00 A G I i
 Q I F D G i E G i

O a A - S () * A ^ a s @
 P B U K O a a ^ a a U d ^ a ^ U a a]
 O E Y K A ^] ~ [c ^ a a a O ~ | r c a a a
 Y ^ a a @ : K A } } ^

O a A a a ^ K S O O C S U O U T
 U a a O j a ^ K E C C C C C I
 U a a O O a a ^ K C B J B D E F G
 U a a ^ A [K F

Groups Printed- Container Trucks

Start Time	Alameda Street Ramp Southbound				Sepulveda Boulevard Westbound				Private Northbound				Sepulveda Boulevard Eastbound				Int. Total
	Left	Thru	Right	App. Total	Left	Thru	Right	App. Total	Left	Thru	Right	App. Total	Left	Thru	Right	App. Total	
04:00 PM	1	0	3	4	0	9	11	20	0	0	0	0	2	13	0	15	39
04:15 PM	8	0	2	10	0	1	10	11	0	0	0	0	2	6	0	8	29
04:30 PM	2	0	1	3	0	9	5	14	0	0	0	0	5	14	0	19	36
04:45 PM	6	0	2	8	0	1	12	13	0	0	0	0	8	9	0	17	38
Total	17	0	8	25	0	20	38	58	0	0	0	0	17	42	0	59	142
05:00 PM	4	0	1	5	0	0	4	4	0	0	0	0	4	8	0	12	21
05:15 PM	4	0	0	4	0	1	3	4	0	0	0	0	5	7	0	12	20
05:30 PM	1	0	1	2	0	1	2	3	0	0	0	0	2	4	0	6	11
05:45 PM	0	0	0	0	0	4	3	7	0	0	0	0	4	2	0	6	13
Total	9	0	2	11	0	6	12	18	0	0	0	0	15	21	0	36	65
Grand Total	26	0	10	36	0	26	50	76	0	0	0	0	32	63	0	95	207
Apprch %	72.2	0	27.8		0	34.2	65.8		0	0	0		33.7	66.3	0		
Total %	12.6	0	4.8	17.4	0	12.6	24.2	36.7	0	0	0	0	15.5	30.4	0	45.9	

Start Time	Alameda Street Ramp Southbound				Sepulveda Boulevard Westbound				Private Northbound				Sepulveda Boulevard Eastbound				Int. Total
	Left	Thru	Right	App. Total	Left	Thru	Right	App. Total	Left	Thru	Right	App. Total	Left	Thru	Right	App. Total	
Peak Hour Analysis From 04:15 PM to 05:00 PM - Peak 1 of 1																	
Peak Hour for Entire Intersection Begins at 04:15 PM																	
04:15 PM	8	0	2	10	0	1	10	11	0	0	0	0	2	6	0	8	29
04:30 PM	2	0	1	3	0	9	5	14	0	0	0	0	5	14	0	19	36
04:45 PM	6	0	2	8	0	1	12	13	0	0	0	0	8	9	0	17	38
05:00 PM	4	0	1	5	0	0	4	4	0	0	0	0	4	8	0	12	21
Total Volume	20	0	6	26	0	11	31	42	0	0	0	0	19	37	0	56	124
% App. Total	76.9	0	23.1		0	26.2	73.8		0	0	0		33.9	66.1	0		
PHF	.625	.000	.750	.650	.000	.306	.646	.750	.000	.000	.000	.000	.594	.661	.000	.737	.816

0[^ } 0 AM | a a a Q & E
 UU A Q c A F F I
 0[| |] a a Q A G I i
 Q I F D G i E d i

0 a r A - S [] * A ^ a s @
 P B U K C H a a ^ a a U d ^ a ^ c U a a]
 O E Y K A ^] ^ [c ^ a a a O [^] c a a a
 Y ^ a a @ : K A ^ } } ^

0 a r A a a ^ K S O O C S U O U T
 U a a A O] a ^ K E C E C E C E I
 U c a a c O a a ^ K C B J B D E F G
 U a a ^ A r [K G

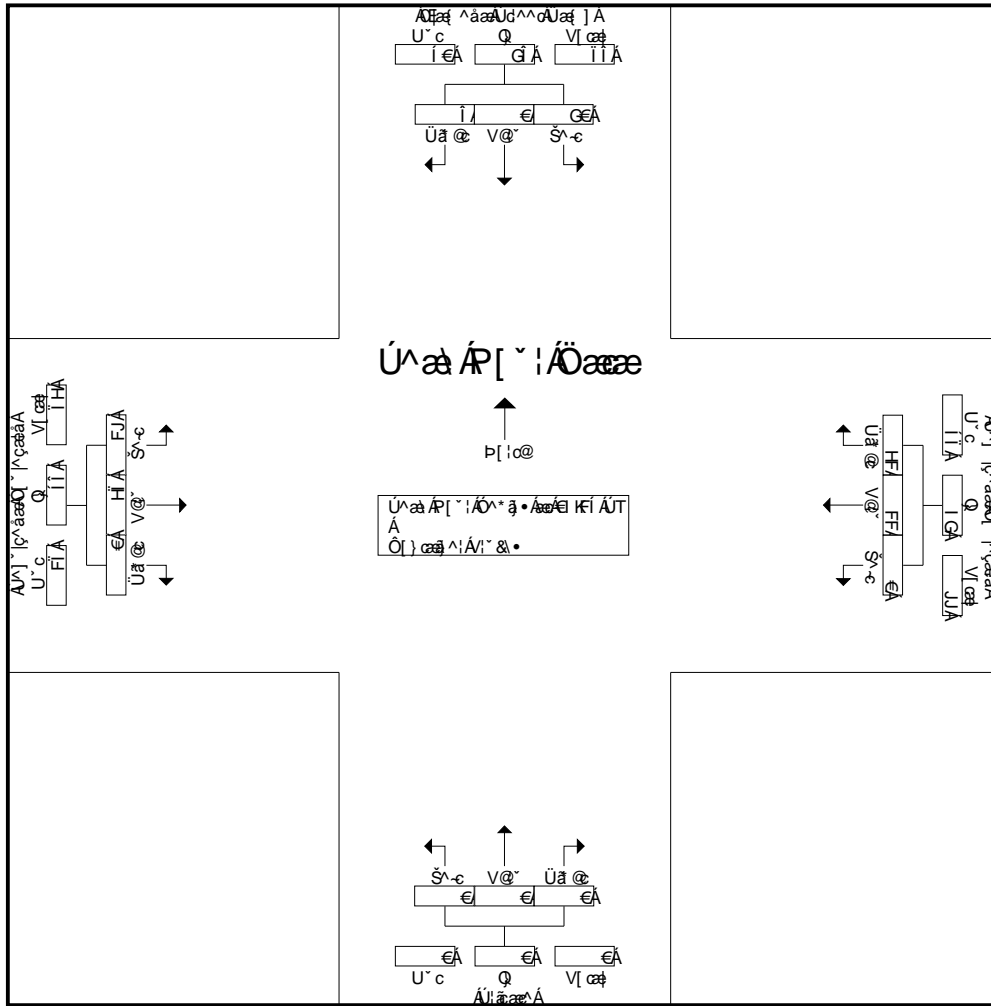

U a a A R [^] A O a a e • a A O [{ A e I K I A U T A e I K E A U T A U U a a A r A - A
 Peak Hour for Each Approach Begins at:

	04:15 PM				04:15 PM				04:15 PM				04:15 PM			
+0 mins.	8	0	2	10	0	1	10	11	0	0	0	0	2	6	0	8
+15 mins.	2	0	1	3	0	9	5	14	0	0	0	0	5	14	0	19
+30 mins.	6	0	2	8	0	1	12	13	0	0	0	0	8	9	0	17
+45 mins.	4	0	1	5	0	0	4	4	0	0	0	0	4	8	0	12
Total Volume	20	0	6	26	0	11	31	42	0	0	0	0	19	37	0	56
% App. Total	76.9	0	23.1		0	26.2	73.8		0	0	0		33.9	66.1	0	
PHF	.625	.000	.750	.650	.000	.306	.646	.750	.000	.000	.000	.000	.594	.661	.000	.737

01 ~ } o ÁM |ã ä á Q&E
 UUÁOí cÁFI í
 Ôí (í) äÖÖÁGíí
 Qí FDí Ë í

Ôä Á -Sí } * Á^æ@
 PDUKÇä äääÜd^^Üä]
 ÖEY KÁ] ~ |c^ääÖí ~ |çää
 Y ^æ@:KÁ } } ^

QÄ Á ç ^ KÖÖÖSÜÖÜT
 Üä ÁÖí ä^ KÉÉÉÉÉ í
 Üää Öää KÇBWBDFG
 Üä ^ Á [KÄ

Groups Printed- Other Trucks

Start Time	Alameda Street Ramp Southbound				Sepulveda Boulevard Westbound				Private Northbound				Sepulveda Boulevard Eastbound				Int. Total
	Left	Thru	Right	App. Total	Left	Thru	Right	App. Total	Left	Thru	Right	App. Total	Left	Thru	Right	App. Total	
04:00 PM	2	3	0	5	2	4	1	7	0	6	0	6	3	5	2	10	28
04:15 PM	0	2	1	3	1	1	2	4	0	1	0	1	1	0	0	1	9
04:30 PM	0	1	1	2	0	0	6	6	0	1	0	1	1	1	0	2	11
04:45 PM	0	6	3	9	0	1	1	2	0	5	0	5	3	0	0	3	19
Total	2	12	5	19	3	6	10	19	0	13	0	13	8	6	2	16	67
05:00 PM	1	4	1	6	0	0	4	4	0	0	0	0	2	3	0	5	15
05:15 PM	4	1	0	5	0	0	2	2	0	4	0	4	2	2	0	4	15
05:30 PM	1	1	1	3	0	0	0	0	0	3	0	3	1	2	0	3	9
05:45 PM	0	2	0	2	0	1	3	4	0	5	0	5	1	0	0	1	12
Total	6	8	2	16	0	1	9	10	0	12	0	12	6	7	0	13	51
Grand Total	8	20	7	35	3	7	19	29	0	25	0	25	14	13	2	29	118
Apprch %	22.9	57.1	20		10.3	24.1	65.5		0	100	0		48.3	44.8	6.9		
Total %	6.8	16.9	5.9	29.7	2.5	5.9	16.1	24.6	0	21.2	0	21.2	11.9	11	1.7	24.6	

Start Time	Alameda Street Ramp Southbound				Sepulveda Boulevard Westbound				Private Northbound				Sepulveda Boulevard Eastbound				Int. Total
	Left	Thru	Right	App. Total	Left	Thru	Right	App. Total	Left	Thru	Right	App. Total	Left	Thru	Right	App. Total	
04:15 PM	0	2	1	3	1	1	2	4	0	1	0	1	1	0	0	1	9
04:30 PM	0	1	1	2	0	0	6	6	0	1	0	1	1	1	0	2	11
04:45 PM	0	6	3	9	0	1	1	2	0	5	0	5	3	0	0	3	19
05:00 PM	1	4	1	6	0	0	4	4	0	0	0	0	2	3	0	5	15
Total Volume	1	13	6	20	1	2	13	16	0	7	0	7	7	4	0	11	54
% App. Total	5	65	30		6.2	12.5	81.2		0	100	0		63.6	36.4	0		
PHF	.250	.542	.500	.556	.250	.500	.542	.667	.000	.350	.000	.350	.583	.333	.000	.550	.711

Peak Hour Analysis From 04:15 PM to 05:00 PM - Peak 1 of 1

Peak Hour for Entire Intersection Begins at 04:15 PM

0[~ } 0 AM | a a a Q & E
 UU A Q c A F I I
 0 [| |] a a 0 0 A G I i
 Q I F D G i E d i

0 a r A - S [] * A ^ a s @
 P B U K C H a a ^ a a U d ^ a ^ a U a a]
 O E Y K A ^ ^] [c ^ a a a 0 [~] c a a a
 Y ^ a a @ : K A ^ } } ^

0 a r A a a ^ K S O O C S U O U T
 U a e A O j a ^ K E C C C C C C i
 U c a s 0 0 a a ^ K C B J B D E F G
 U a e ^ A r [K G

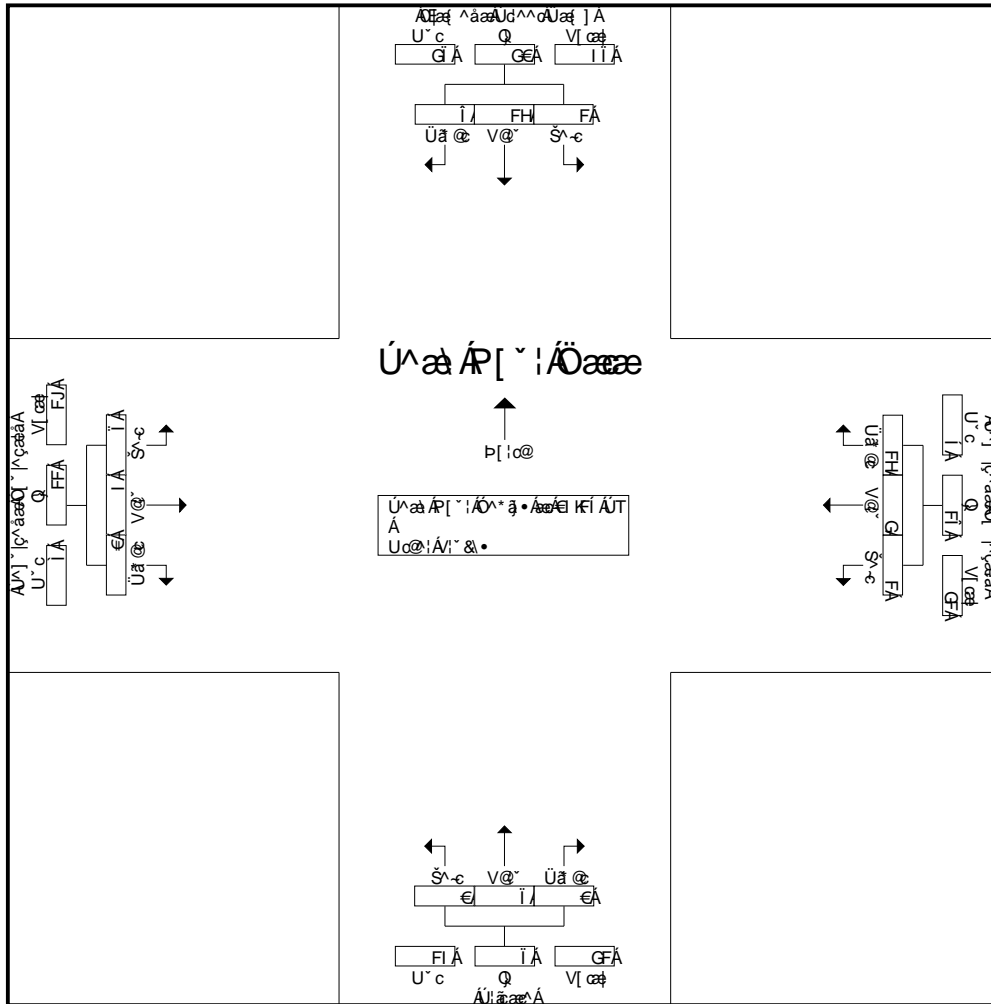

U ^ a a A r [~] A O a a e • a A O [{ A e K I A U T A e A e K A U T A U ^ a a A r A - A
 Peak Hour for Each Approach Begins at:

	04:15 PM				04:15 PM				04:15 PM				04:15 PM			
+0 mins.	0	2	1	3	1	1	2	4	0	1	0	1	1	0	0	1
+15 mins.	0	1	1	2	0	0	6	6	0	1	0	1	1	1	0	2
+30 mins.	0	6	3	9	0	1	1	2	0	5	0	5	3	0	0	3
+45 mins.	1	4	1	6	0	0	4	4	0	0	0	0	2	3	0	5
Total Volume	1	13	6	20	1	2	13	16	0	7	0	7	7	4	0	11
% App. Total	5	65	30		6.2	12.5	81.2		0	100	0		63.6	36.4	0	
PHF	.250	.542	.500	.556	.250	.500	.542	.667	.000	.350	.000	.350	.583	.333	.000	.550

Ö|~}•ÁV|ã ã^áÁ&É
 UUÁÖ|çÁFÍÍ
 Ö|{ }ãÖÖÁGÍÍ
 Q|FÖGÍÉGÍ

Öã: Á-Á[]*ÁÖã@
 ÞÖU|Öç|{ [ããÁ æ
 ÖËY KÁU| }ç^ããÖ| }çããá
 Y^ãã@:KÁU| } } }

Öã: Áã ã ^ KÖÖÖÖ ÖÜÖÇÊ
 Üã:ÁÖ| á^ KEEEEEEF
 ÜããÖÖã KÖÖHDEFG
 Üã^Á| KÆ

Ö|{ }•ÁV|ã ç^áÁ&É • ÁÖ|ããÁV| } & • ÁÖ|ããáÁU| } ÁV| } & • ÁÖ| } çã^ÁV| } & • ÁV|ç@:ÁV| } & •

ÜããÁV ^	Qç { [ããÁ æ U ç@ } á			Ü^ } ç^ããÖ } çããá Y^•çá } á			Ü^ } ç^ããÖ } çããá Öãçá } á			QçÁV çã
	Š^c	Üã @	Ö } ÉV çã	V@~	Üã @	Ö } ÉV çã	Š^c	V@~	Ö } ÉV çã	
É KÉÖÇÊ	ì	H	FF	Fíì	€	Fíì	€	íí	íí	GÍ
É KÍ ÁÇÊ	F€	I	FÍ	Fíí	€	Fíí	€	Féí	Féí	GÍ
É KÉÁÇÊ	F€	I	FÍ	Fíí	€	Fíí	G	FÇH	FÇH	HG
É KÍ ÁÇÊ	Fí	G	FJ	FíJ	G	FJF	€	Fíí	Fíí	HÍ
V çã	íí	FH	íí	ííí	G	ííJ	G	ííF	ííH	FG€€
É KÉÖÇÊ	FF	H	FÍ	Fíí	F	Fíí	F	FHí	FHí	HÉí
É KÍ ÁÇÊ	Fí	€	Fí	Fíí	€	Fíí	F	FFí	FFí	G J
É KÉÁÇÊ	G	G	GH	FGJ	€	FGJ	€	FÇG	FÇG	GÍ
É KÍ ÁÇÊ	G€	H	GH	FFG	€	FFG	€	Féí	Féí	GH
V çã	íí	í	íí	ííH	F	ííH	G	íí€	ííG	F€JG
Ö ã ãÁV çã	FFH	G	FH	FG€	H	FGFH	I	JIF	Jíí	GGJG
Ö } :&@Á	ííÉH	FíÉ	Á	JJÉ	€É	Á	€É	JJÉ	Á	Á
V çãÁ	IÉ	€É	íÉ	íGÉ	€É	íGÉ	€É	I FÉ	I FÉ	
Üã•^ } *^Á^ Ç@ ^•	G	€	G	FéJ	F	Fé€	G	ííí	ííí	Fí Ç€
Á ÁÜã•^ } *^Á^ Ç@ ^•	FÉ	€	FÉ	ííÉ	HÉ	ííÉ	í€	ííÉ	ííÉ	íí
Ö çãÁV } &•	€	F	F	H€	F	H€	€	Fíí	Fíí	Fí J
Á ÁÖ çãÁV } &•	€	IÉ	€É	GÉ	HÉ	GÉ	€	FíÉ	FíÉ	í É
Ö çã á ÁU } ÁV } &•	€	€	€	í	€	í	€	í	í	FG
Á ÁÖ çã á ÁU } ÁV } &•	€	€	€	€É	€	€É	€	€É	€É	€É
Ö } çã^ÁV } &•	FF€	G€	FHE	H	F	H	€	í€	í€	GÍ
Á ÁÖ } çã^ÁV } &•	JíÉH	JíÉG	Jí	HÉ	HÉ	HÉ	€	íÉH	íÉH	JÉ
Uç@:ÁV } &•	F	€	F	íí	€	íí	G	íG	íí	FíH
Á ÁUç@:ÁV } &•	€É	€	€É	íÉ	€	íÉ	í€	íÉ	íÉ	íÉ

ÜããÁV ^	Qç { [ããÁ æ U ç@ } á			Ü^ } ç^ããÖ } çããá Y^•çá } á			Ü^ } ç^ããÖ } çããá Öãçá } á			QçÁV çã
	Š^c	Üã @	Ö } ÉV çã	V@~	Üã @	Ö } ÉV çã	Š^c	V@~	Ö } ÉV çã	
ÜããÁV } ÁV çã • á ÁÖ { ÁÉ KÉÖÇÊ ÁÉ KÍ ÁÇÊ ÁV çã ÁV çã										
ÜããÁV } ÁV çã :ÁV çã :ÁV çã :ÁV çã :ÁV çã :ÁV çã :ÁV çã										
É KÍ ÁÇÊ	F€	4	FÍ	Fíí	€	Fíí	€	Féí	Féí	GÍ
É KÉÁÇÊ	F€	I	FÍ	Fíí	€	Fíí	2	FÇH	FÇH	HG
É KÍ ÁÇÊ	17	G	19	189	2	191	€	147	147	357
É KÉÖÇÊ	FF	H	FÍ	Fíí	F	Fíí	F	FHí	FHí	HÉí
V çãÁV } ^	íí	FH	íí	ííí	H	ííí	H	ííF	ííF	FÇH
Á ÁUç ÉV çã	ííÉ	GÉH	Á	JJÉ	€É	Á	€É	JJÉ	JJÉ	Á
UPØ	É€	ÉFH	É€H	É€	Éí	É€F	Éíí	ÉíJ	Éíí	Éíí

Ó[~] • ÁY | ä ä Á Q & E
 UU Á Ö c Á F I I
 Ö I I I } ä Ö Ö Á G I I
 Q I F D G I È G I

Óä Á - Á I } * Á Ö ä @
 P D U I K Ö c I { [ä ä Á Y ä
 Ö E Y K Á U ^ } | c ^ ä ä Ö I ~ | c ç ä ä
 Y ^ ä ä @ : K Á U } } ^

Ö ä Á P ä ^ K Ö Ö Ö Ö Ö Ö Ö Ö
 Ü ä Á Ö I ä ^ K E E E E E E F
 Ü ä Ö Ö Ö ä ^ K G H H E F G
 Ü ä ^ Á P | K F

Ö I I ~] • Á Y | ä ä Á Q & E * Á I K Á Ö I I

Ü ä Ö Á Y ä ^	Q c I { [ä ä Á Y ä U I ~ c Ö I ~ } ä			Ü Á ~ c ^ ä ä Ö I ~ c ç ä ä Y ^ • c ä I ~ } ä			Ü Á ~ c ^ ä ä Ö I ~ c ç ä ä Ö ä c ä I ~ } ä			Q c Ä V c ç
	Š ^ c	Ü ä @	Ö I È V c ç	V @ ~	Ü ä @	Ö I È V c ç	Š ^ c	V @ ~	Ö I È V c ç	
È I K E Á Ö F	€	€	€	F H	€	F H	€	Ï H	Ï H	G E F
È I K I Á Ö F	€	€	€	F I G	€	F I G	€	Ï G	Ï G	G F I
È I K E Á Ö F	F	€	€	F I I	€	F I I	F	J I	J I	G I I
È I K I Á Ö F	€	€	€	F I G	F	F I H	€	F E H	F E H	G I I
V c ç	F	€	F	Ï G E	F	Ï G F	F	H H	H I	J I I
È I K E Á Ö F	€	€	€	F H	€	F H	F	J F	J G	G H E
È I K I Á Ö F	€	€	€	F F I	€	F F I	€	Ï F	Ï F	F J I
È I K E Á Ö F	F	€	F	F È I	€	F È I	€	Ï I	Ï I	F I H
È I K I Á Ö F	€	€	€	J F	€	J F	€	Ï I	Ï I	F I I
V c ç	F	€	F	I I J	€	I I J	F	H F H	H F I	Ï I I
Ö I ä ä Á V c ç	G	€	G	F È J	F	F È I	G	Ï I	Ï I	F I G E
Ö I I : & @ Á	F E €	€	Á	J J È	€ È F	Á	€ È H	J J È	Á	Á
V c ç Á	€ È F	€	€ È F	Ï G G	€ È F	Ï G G	€ È F	H È È	H È È	

Ü ä Ö Á Y ä ^	Q c I { [ä ä Á Y ä U I ~ c Ö I ~ } ä			Ü Á ~ c ^ ä ä Ö I ~ c ç ä ä Y ^ • c ä I ~ } ä			Ü Á ~ c ^ ä ä Ö I ~ c ç ä ä Ö ä c ä I ~ } ä			Q c Ä V c ç
	Š ^ c	Ü ä @	Ö I È V c ç	V @ ~	Ü ä @	Ö I È V c ç	Š ^ c	V @ ~	Ö I È V c ç	
È I K I Á Ö F	€	€	€	F I G	€	F I G	€	Ï G	Ï G	G F I
È I K E Á Ö F	1	€	1	F I I	€	F I I	1	J I	J I	G I I
È I K I Á Ö F	€	€	€	172	1	173	€	103	103	276
È I K E Á Ö F	€	€	€	F H	€	F H	F	J F	J G	G H E
V c ç X I ~ } ^	F	€	F	Ï G E	F	Ï G F	G	H F	H H	J I I
Á Ö I È V c ç	F E €	€	Á	J J È	€ È G	Á	€ È H	J J È	Á	Á
U P Ø	È I €	È E €	È I €	È È F	È I €	È È J I	È È €	È È I	È È F	È È J G

Ü ä Ö Á P I ~ | c ç ä ä • ä Á I I { È I K I Á Ö F È I K E Á Ö F Ü ä Ö Á Y ä Á F Á F
 Ü ä Ö Á P I ~ | c ç ä ä • ä Á I I { È I K I Á Ö F È I K E Á Ö F Ü ä Ö Á Y ä Á F Á F

Ö[] ÖÄ |ä ääÄ&E
 UUÄÖ cÄFFii
 Ö[]] ääÖÄGii
 QI FÄi E äi

Öä Ä -Ä[] *Äöä@
 ÞEUKÖc[] { ääÄ ä
 ÖEY KÄ^] [ç^ ääÖ[] ^çä ä
 Y ^ ää@:KÄ" } } ^

Öä Ä ä ^ KÄÖÖÖÜÖE
 Üä ÄÖ[] ä ^ KÄÖÖÖÖÖF
 Üä ä Öä ^ KÄÖHDEFG
 Üä ^ Ä[] KÄG

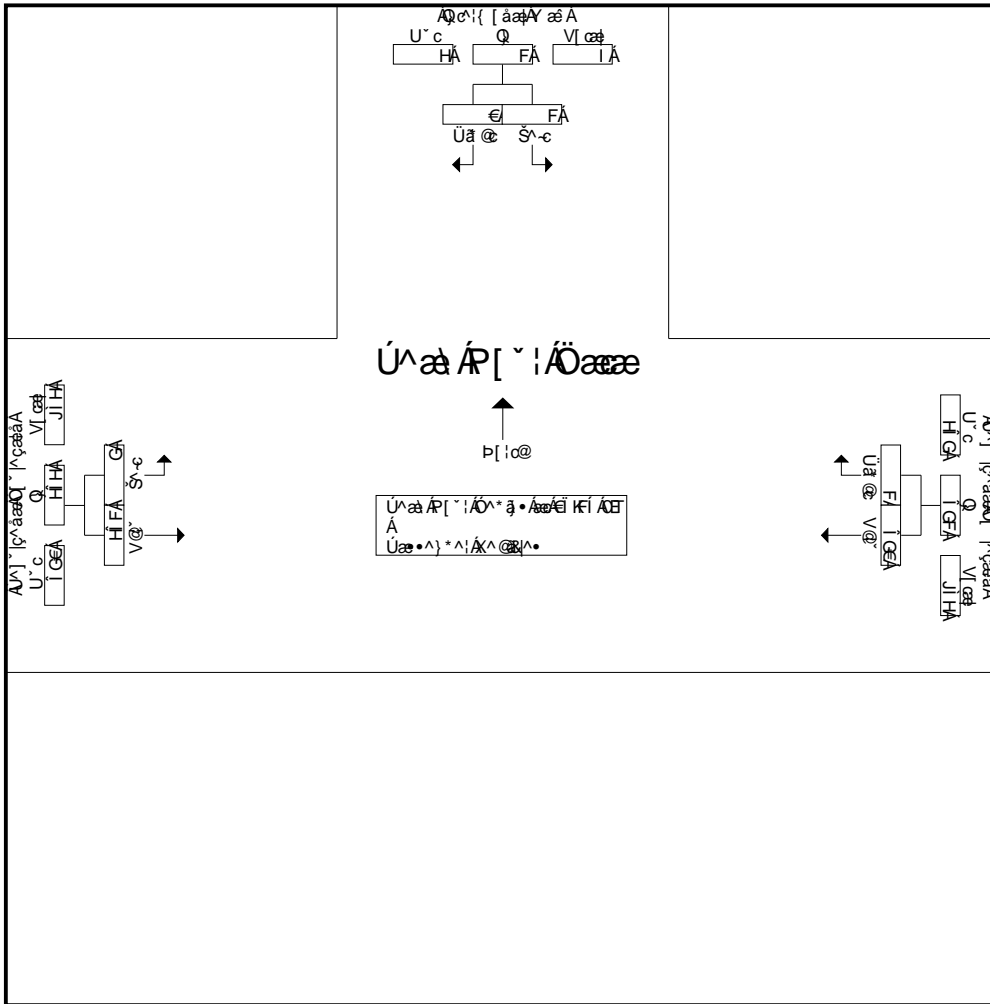

Ú^ä ÄR[] ^ |ÄÖäææ
 Ú^ä ÄR[] ^ |ÄÖäææ

	€	€	€	€	€	€	€	€	€
ÉÉÄ ä •É	€	€	€	FIG	€	FIG	€	ïG	ïG
ÉFÄ ä •É	1	€	1	Fîi	€	Fîi	1	Jí	Jí
ÉHÄ ä •É	€	€	€	172	€	173	€	103	103
ÉiÄ ä •É	€	€	€	FH	€	FH	F	JF	JG
V[] Ä [] ^	F	€	F	îG	F	îG	G	HíF	HíH
Ä Ö [] E V[]	F€€	€	Ä	JJÉ	€€	Ä	€€	JJÉ	Ä
UPØ	€€	€€€	€€	ÉÉF	€€	ÉÉ	€€	ÉÉ	ÉÉ

Ö[] • ÁV[] ä á ÁQ&É
 UUÁÖ[] cÁFíí
 Ö[] () äÖÖÁGíí
 Qí FíGí í È Gí

Öä Á -Á[] * ÁÖä@
 ÞÖU[] Ö[] { [äáÁV ä
 ÖY KÁV[] {c^ääÖ[] ^cääá
 Y ^ää@:KÁV[] } }

Öä ÁV[] ^ KÖÖÖÖÖÖÖÖÖÖ
 Üä ÁÖ[] ä^ KÖÖÖÖÖÖÖÖÖÖ
 ÜääÖÖä KÖÖÖÖÖÖÖÖÖÖ
 Üää^Á[] KÖÖÖÖÖÖÖÖÖÖ

Ö[] • ÁV[] ä á ÁQ&É

ÜääÖÁV[] ^	Ö[] { [äáÁV ä U[] cÖ[] } ä			Ü[] ^ {c^ääÖ[] ^cääá Y ^•cá[] } ä			Ü[] ^ {c^ääÖ[] ^cääá Öääcá[] } ä			Q cÁV[] cö
	Š^c	Üä @	Ö[] ÈV[] cö	V@~	Üä @	Ö[] ÈV[] cö	Š^c	V@~	Ö[] ÈV[] cö	
€	€	€	€	€	€	€	€	Fí	Fí	Fí
€	€	€	€	G	€	G	€	GG	GG	G
€	€	F	F	G	€	G	€	Fí	Fí	Fí
€	€	€	€	€	€	€	€	ÖE	ÖE	ÖE
V[] cö	€	F	F	I	€	I	€	íí	íí	í€
€	€	€	€	€	F	F	€	GG	GG	GH
€	€	€	€	FH	€	FH	€	ÖE	ÖE	HH
€	€	€	€	J	€	J	€	GG	GG	HF
€	€	€	€	I	€	I	€	Fí	Fí	GG
V[] cö	€	€	€	G	F	G	€	ìG	ìG	FÈJ
Ö[] äÁV[] cö	€	F	F	H€	F	HF	€	Fíí	Fíí	FíJ
Ö[] :&Ö[]	€	F€€	Á	Jí È	H€G	Á	€	F€€	Á	Á
V[] cöÁ	€	ÈÈ	ÈÈ	Fí È	ÈÈ	Fí È	€	ìHÈ	ìHÈ	

ÜääÖÁV[] ^	Ö[] { [äáÁV ä U[] cÖ[] } ä			Ü[] ^ {c^ääÖ[] ^cääá Y ^•cá[] } ä			Ü[] ^ {c^ääÖ[] ^cääá Öääcá[] } ä			Q cÁV[] cö
	Š^c	Üä @	Ö[] ÈV[] cö	V@~	Üä @	Ö[] ÈV[] cö	Š^c	V@~	Ö[] ÈV[] cö	
€	€	€	€	2	€	2	€	22	22	24
€	€	1	1	G	€	G	€	Fí	Fí	Fí
€	€	€	€	€	€	€	€	ÖE	ÖE	ÖE
€	€	€	€	€	1	F	€	GG	GG	GH
V[] cöK[] ^	€	F	F	I	F	I	€	íJ	íJ	íí
Á Ö[] ÈV[] cö	€	F€€	Á	ì€	ÖE	Á	€	F€€	Á	Á
UPØ	È€€	È€	È€	È€€	È€	ÈG	È€€	ÈJí	ÈJí	Èíí

Ó[] , o ÁM |ã, äããQ&É
 UUÁQ| c ÁFII
 Ó[] | } äããQ&É
 QI FÁQI È G I

Óã Á -Á[] * ÁQã@
 PBUKQ c { [äããY äé
 ÖEY KÁU^] ç^ äããQ | ^ çããä
 Y ^ äãã@ : KÁU^ } } ^

Qã ÁPãä ^ KãSÓQ Q ÚQCE
 Úã ÁQ | ä^ KãE E E E E E E F
 ÚãããQãã KãG H E D E F G
 Úãã ^ ÁP | KãG

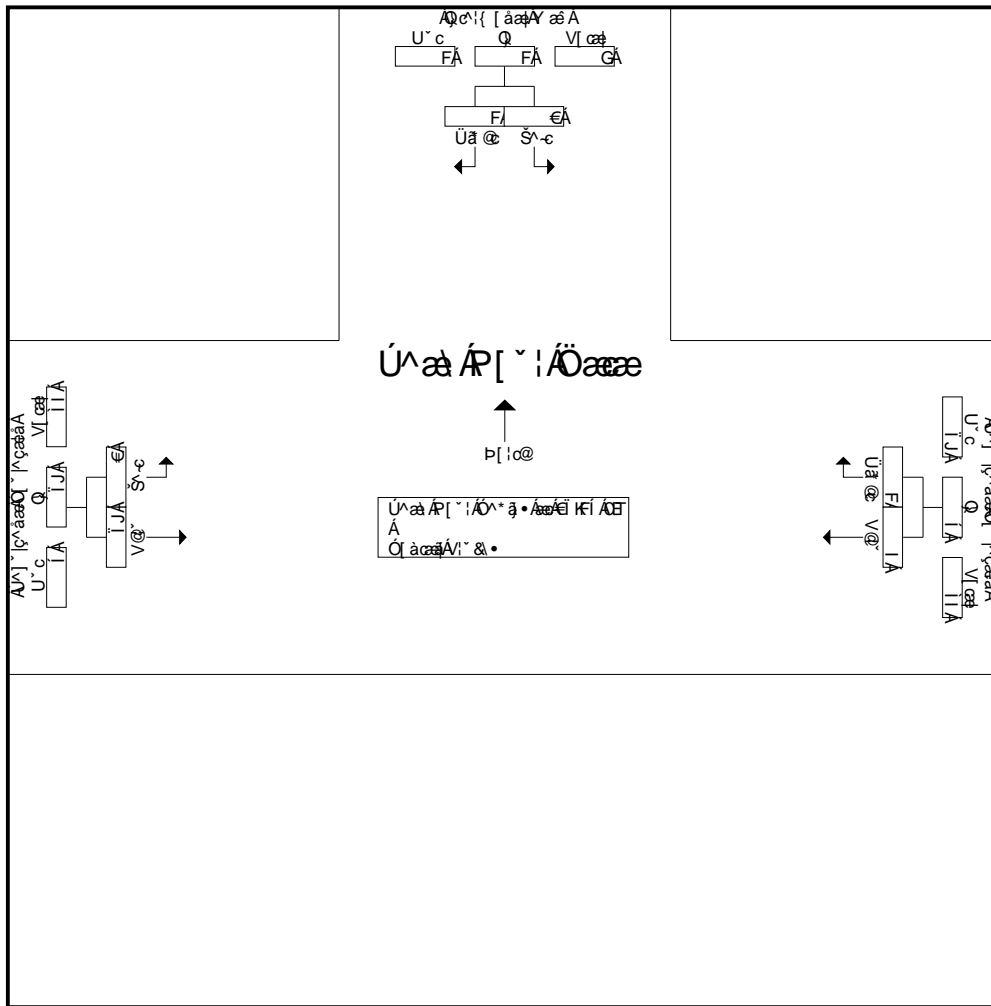

Ú^äã ÁP[^ | ÁCE äã • äã ÁQ [{ ÁE KFI ÁCE ÁE ÁE KãCE ÁE Ú^äã ÁP[^ | ÁCE
 Ú^äã ÁP[^ | ÁQ | ÁQããQ] | äããQ ^ äããK

	€ KFI ÁCE			€ KFI ÁCE			€ KFI ÁCE		
É€Á ä • È	€	€	€	2	€	2	€	22	22
ÉFI Á ä • È	€	1	1	G	€	G	€	FÍ	FÍ
ÉHEÁ ä • È	€	€	€	€	€	€	€	Q€	Q€
ÉI Á ä • È	€	€	€	€	1	F	€	GG	GG
V cããK] { ^	€	F	F	I	F	I	€	I J	I J
Á ÁQ ÈV cãã	€	F€€	Á	I €	Q€	Á	€	F€€	Á
ÚPØ	€€€	€€ €	€€ €	€€ €€	€€ €	€€ €	€€€	€€ JÍ	€€ JÍ

Ö[~]•ÁV|ã äãÁQ&É
 UUÁÖ|çÁFI
 Ö[~]•áÖÖáGíi
 QI FÖG i È G i

Öã Á -Á[] * ÁÖã@
 PDUKÖç: { [äãÁ æ
 ÖY KÁ^ } |ç^ääÖ | ^çääá
 Y ^ã@:KÁ } } ^

Öã Áã ^ KÖÖÖÖÖÖÖÖÖ
 Üã ÁÖ | ä ^ KÖÖÖÖÖÖÖÖ
 Üã ÖÖã ^ KÖÖÖÖÖÖÖÖ
 Üã ^ Á | KÖ

Ö[~]•ÁV|ã äãÁQ&É

Üã Ö Á ^	Qç: { [äãÁ æ U çã } ä			Ü^ ç^ääÖ ^çääá Y ^•çã } ä			Ü^ ç^ääÖ ^çääá Öã çã } ä			Q çã çã
	Š^c	Üã @	Ö ÈV çã	V@~	Üã @	Ö ÈV çã	Š^c	V@~	Ö ÈV çã	
è KÈÁÖF	€	€	€	€	€	€	€	€	€	€
è KÍ ÁÖF	€	€	€	€	€	€	€	F	F	F
è KÈÁÖF	€	€	€	€	F	€	€	€	€	€
è KÍ ÁÖF	€	€	€	€	G	€	€	G	G	G
V çã	€	€	€	€	H	€	€	H	H	í
è KÈÁÖF	€	€	€	€	F	€	€	F	F	G
è KÍ ÁÖF	€	€	€	€	€	€	€	€	€	€
è KÈÁÖF	€	€	€	€	€	€	€	F	F	F
è KÍ ÁÖF	€	€	€	€	G	€	€	G	G	H
V çã	€	€	€	€	H	€	€	H	H	í
Ö äã ÁV çã	€	€	€	€	í	€	€	í	í	FG
Ö : & @ Á	€	€	€	€	F€€	€	€	F€€	€	Á
V çã Á	€	€	€	€	í€	€	€	í€	í€	Á

Üã Ö Á ^	Qç: { [äãÁ æ U çã } ä			Ü^ ç^ääÖ ^çääá Y ^•çã } ä			Ü^ ç^ääÖ ^çääá Öã çã } ä			Q çã çã
	Š^c	Üã @	Ö ÈV çã	V@~	Üã @	Ö ÈV çã	Š^c	V@~	Ö ÈV çã	
è KÍ ÁÖF	€	€	€	€	€	€	€	F	F	F
è KÈÁÖF	€	€	€	€	F	€	€	€	€	F
è KÍ ÁÖF	€	€	€	€	2	€	€	2	2	4
è KÈÁÖF	€	€	€	€	F	€	€	F	F	G
V çã } ^	€	€	€	€	l	€	€	l	l	í
Á Ö ÈV çã	€	€	€	€	F€€	€	€	F€€	€	Á
UP Ø	€€€	€€€	€€€	€€€	È €€	È €€€	È €€	È €€	È €€	È €€

Ö[] • ÁY | ä ä ÁQ&É
 UUÁÖ cÁFI I
 Ö[] : äÖÖÁGII
 QI FDG i È G I

Öä Á -Á[] * ÁÖä@
 ÞEUIKÖc[] { [äáY ä
 ÖEY KÁ^] [c^ääÖ[] ^cää
 Y ^ä@:KÁ^] }

Öä Á ä ^ KÖÖÖÖ ÖÖÖÖ
 Üä Á Ö[] ä ^ KÖÖÖÖÖÖÖ
 Ücää Öä ^ KÖÖÖÖÖÖÖ
 Üä ^ Á[] KÖ

Ö[] • ÁY | ä ä ÁQ&É [] Ö[] ÁY | ä ä ÁQ&É

Ücää ÁY ^	Öc[] { [äáY ä Ü[] cÖ[] } ä			Ü^] [c^ääÖ[] ^cää Y ^•cá[] } ä			Ü^] [c^ääÖ[] ^cää Öc cá[] } ä			Q cÁV[] cö
	Š^c	Üä @	Ö[] ÈV[] cö	V@~	Üä @	Ö[] ÈV[] cö	Š^c	V@~	Ö[] ÈV[] cö	
èi KÖÖÖ	i	H	FF	i	€	i	€	€	€	Fi
èi KÍ ÁÖ	F€	I	FI	I	€	I	€	G	G	ÖE
èi KÖÖÖ	J	H	FG	I	€	I	€	G	G	Fi
èi KÍ ÁÖ	Fí	G	FJ	I	F	í	€	FG	FG	Hí
V[] cö	II	FG	íí	Fí	F	Fí	€	Fí	Fí	I J
èi KÖÖÖ	FF	H	FI	H	€	H	€	F€	F€	Gí
èi KÍ ÁÖ	Fí	€	Fí	F	€	F	€	i	i	G
èi KÖÖÖ	ÖE	G	GG	i	€	i	€	F€	F€	I €
èi KÍ ÁÖ	ÖE	H	GH	J	€	J	€	í	í	Hí
V[] cö	íí	i	íi	GF	€	GF	€	Hí	Hí	FGJ
Ö[] ä ÁY[] cö	FF€	ÖE	FHE	Hí	F	Hí	€	í €	í €	GFí
Ö[] : & ÖÁ	i i È	Fí È	Á	Jí È	ÖÈ	Á	€	F€€	Á	Á
V[] cö Á	i €È	JÈG	í JÈ	Fí	€È	Fí È	€	GÖÈ	GÖÈ	

Ücää ÁY ^	Öc[] { [äáY ä Ü[] cÖ[] } ä			Ü^] [c^ääÖ[] ^cää Y ^•cá[] } ä			Ü^] [c^ääÖ[] ^cää Öc cá[] } ä			Q cÁV[] cö
	Š^c	Üä @	Ö[] ÈV[] cö	V@~	Üä @	Ö[] ÈV[] cö	Š^c	V@~	Ö[] ÈV[] cö	
èi KÍ ÁÖ	F€	4	FI	4	€	I	€	G	G	ÖE
èi KÖÖÖ	J	H	FG	I	€	I	€	G	G	Fi
èi KÍ ÁÖ	17	G	19	I	1	5	€	12	12	36
èi KÖÖÖ	FF	H	FI	H	€	H	€	F€	F€	Gí
V[] cö K[] ^	II	FG	í J	Fí	F	Fí	€	Gí	Gí	F€F
Á Ö[] ÈV[] cö	í JÈ	GÈH	Á	JHÈ	í ÈG	Á	€	F€€	Á	Á
UPØ	È JF	È í €	È íí	È H	È €	È €€	È €€	È I G	È I G	È €F

Üä Á Á[] : Ö[] ä ÁY[] cö { èi KÍ ÁÖ èi KÖÖÖ èi KÍ ÁÖ }
 Üä Á Á[] : Á[] Ö[] cÁQc[] : ^ ä Ö[] : ÁÖ^ ä • Á èi KÍ ÁÖ

Ó[] , o ÁM |ã, ãããQ&É
 UUÁQ c ÁFII
 Ó[] } ãããQ&É
 QI FQ&É Ë Ë

Óã Á -Á[] * ÁQ&@
 P&UQ&@ { [ããÁ ã
 ÓEY KÁ^] [ç^ããQ [^çãã
 Y ^ãã@ : KÁ^ } }

Q& ÁP& ^ K&SÓQ& ÚÓQ&E
 Úã ÁQ [ã^ K&E&E&E&E&E&E&E
 ÚããQ&O&ã K&G&H&E&F&G
 Úãã^ ÁP [K&G

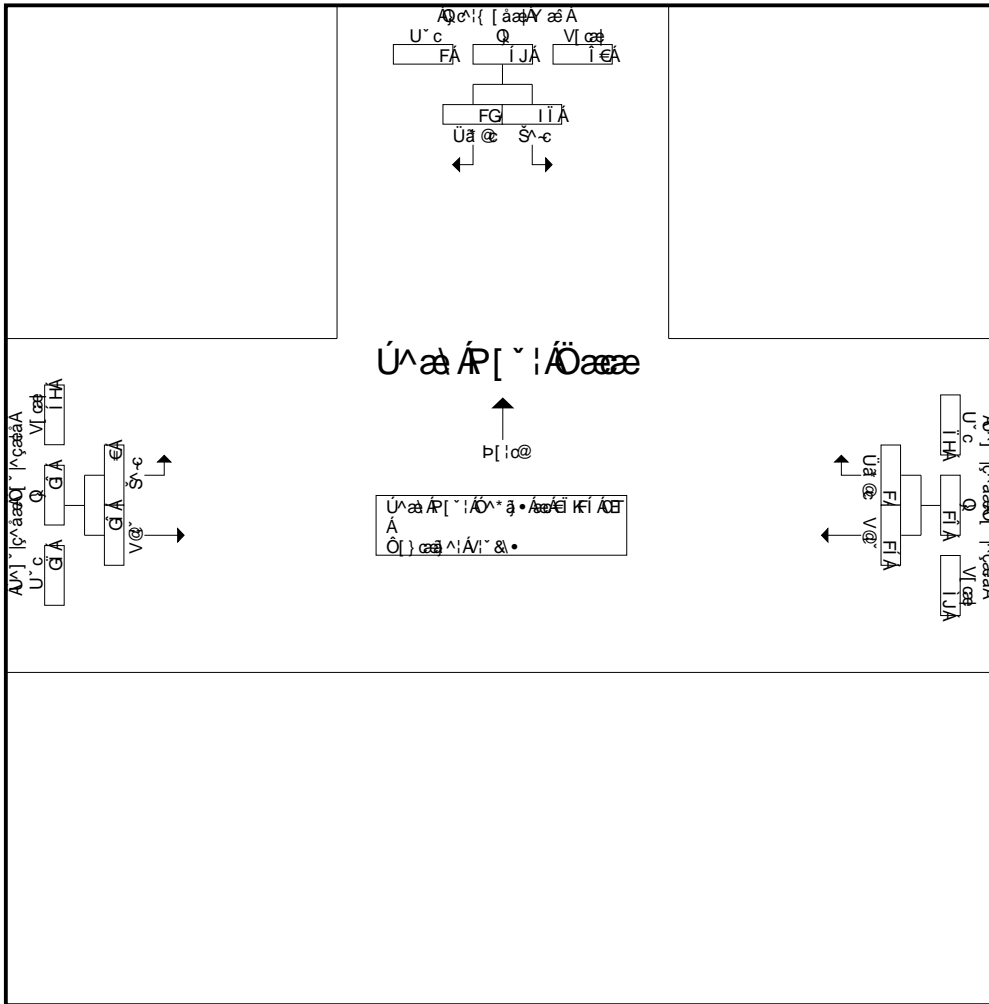

Ú^ã ÁP [^ | ÁQ&E ã • ÁQ [[ÁE KFI ÁQ&E ÁE ÁE K&E&E&E ÁÚ^ã ÁKÁ -Á
 Ú^ã ÁP [^ | ÁQ&E Q&E] [ããQ&E^ã • ÁãK

	EÍ KFI ÁQ&E			EÍ KFI ÁQ&E			EÍ KFI ÁQ&E		
EÉÁ ã • E	FE	4	FI	4	€	I	€	G	G
EÍÁ ã • E	J	H	FG	I	€	I	€	G	G
EÉÁ ã • E	17	G	19	I	1	5	€	12	12
EÍÁ ã • E	FF	H	FI	H	€	H	€	FE	FE
VI c&ãK[] { ^	IÍ	FG	I J	FI	F	FÍ	€	G	G
Á Q&E] E V [c&ã	I J E	G&E H	Á	J H E	I E G	Á	€	FE	Á
ÚPØ	E J F	E I €	E I I	E H	E €	E €	E €	E I G	E I G

Ö[]·ÁÁ|ä ä·ÁÁ&É
 ÚÚÁÖ|ÁÁÍÍ
 Ö[]·ááÖÁÁÍÍ
 Ö[]·ááÖÁÁÍÍ

Öá Á-Á[]·ÁÖá@
 ÞÖÚÁÖ[]·ááÁ á
 ÖÉY ÁÁ[]·ááÁÖ[]·Áçáá
 Y^á@:ÁÁ[]·

Öá Á·á ^ ÁÖÖÖÖÖÖÖÖÖ
 Úá ÁÖ[]·á ^ ÁÖÖÖÖÖÖÖÖÖ
 Úá ÖÖÖÖÖÖÖÖÖÖ
 Úá Á·Á[]· Á

Ö[]·ÁÁ|ä ä·ÁÁ&É

ÚááÁ·Á ^	Ö[]·ááÁ á Ú[]·áá[]·á			Ú[]·ááÁÖ[]·Áçáá Y^·á[]·á			Ú[]·ááÁÖ[]·Áçáá Öáá[]·á			Ö[]·áá[]·á
	Á·c	Úá @	Ö[]·áá[]·á	V@	Úá @	Ö[]·áá[]·á	Á·c	V@	Ö[]·áá[]·á	
É ÁÖÖÖ	€	€	€	í	€	í	€	í	í	FE
É ÁÍ ÁÖ	€	€	€	í	€	í	€	J	J	FÍ
É ÁÖÖÖ	€	€	€	FE	€	FE	€	FF	FG	GG
É ÁÍ ÁÖ	€	€	€	FF	€	FF	€	FE	FE	GF
V[]·áá[]·á	€	€	€	H	€	H	€	F	H	ÍJ
É ÁÖÖÖ	€	€	€	FI	€	FI	€	FF	FF	Í
É ÁÍ ÁÖ	F	€	F	í	€	í	€	í	í	FÍ
É ÁÖÖÖ	€	€	€	í	€	í	€	FÍ	FÍ	GG
É ÁÍ ÁÖ	€	€	€	í	€	í	€	FI	FI	GE
V[]·áá[]·á	F	€	F	H	€	H	€	F	ÍÍ	ÍJ
Ö[]·áá[]·á	F	€	F	íí	€	íí	€	G	íG	íí
Ö[]·áá[]·á	FE	€	Á	FE	€	Á	€	GÍ	JÍÉ	Á
V[]·áá[]·á	ÉÉ	€	ÉÉ	ÍÍÉ	€	ÍÍÉ	€	FÉH	ÍÉ	ÍÍÉ

ÚááÁ·Á ^	Ö[]·ááÁ á Ú[]·áá[]·á			Ú[]·ááÁÖ[]·Áçáá Y^·á[]·á			Ú[]·ááÁÖ[]·Áçáá Öáá[]·á			Ö[]·áá[]·á
	Á·c	Úá @	Ö[]·áá[]·á	V@	Úá @	Ö[]·áá[]·á	Á·c	V@	Ö[]·áá[]·á	
É ÁÍ ÁÖ	€	€	€	í	€	í	€	J	J	FÍ
É ÁÖÖÖ	€	€	€	FE	€	FE	1	11	12	GG
É ÁÍ ÁÖ	€	€	€	FF	€	FF	€	FE	FE	GF
É ÁÖÖÖ	€	€	€	14	€	14	€	FF	FF	25
V[]·áá[]·á	€	€	€	IG	€	IG	F	IF	IG	ÍÍ
Á Ö[]·áá[]·á	€	€	Á	FE	€	Á	GÍ	JÍÉ	Á	Á
UPØ	ÉÉÉ	ÉÉÉ	ÉÉÉ	ÉÍÉ	ÉÉÉ	ÉÍÉ	ÉÍÉ	ÉHG	ÉÍÍ	ÉÍÉ

Ó[~}oÁM|ã,ãããQ&É
 UUÁQ]cÁFII
 Ó[!|]ããÖÖÁGII
 QI FÁGII È Ì

Óã Á -Á[]*Ácã@
 PÉUÁQc{ [ããÁ æ
 ÖEY ÁU^] [ç^ããÖ]~'çããã
 Y^ãã@:ÁU" } } ^

Qã Á pã ^ K&SÓÓQ ÙÖCE
 Úã ÁÖ] á^ K&E&E&E&E&E
 ÚcãcÖãæ K&G&H&E&F&G
 Úæ^Ár K&G

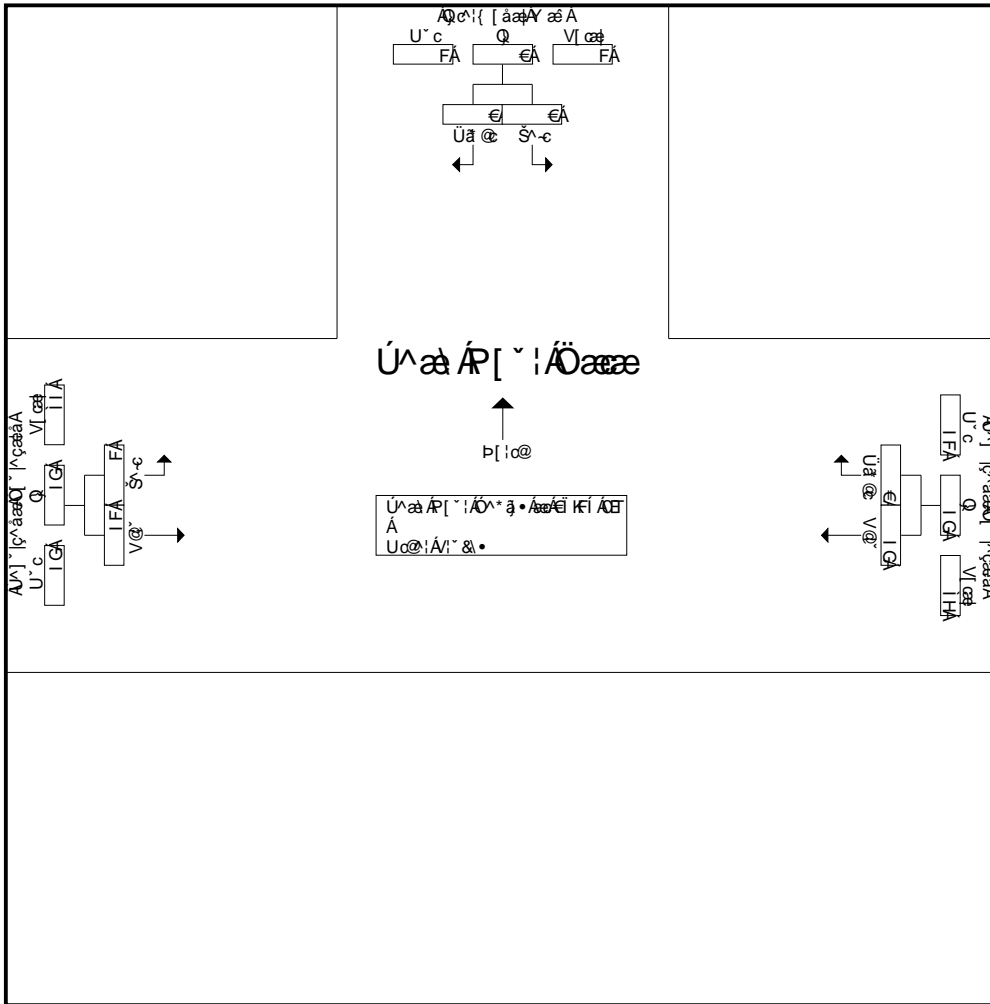

Ú^ãã ÁR [~ | ÁÖææ *ã ÁÖ [(ÁÈ KFI ÁÖÈ ÁÈ ÁÈ K&E&E&E ÁU^ãã ÁÁ -Á
 Ú^ãã ÁR [~ | ÁÖææ ÖEY ÁU^] [ç^ããÖ]~'çããã

Ú^ãã ÁR [~ ÁÖææ	ÁÈ KFI ÁÖÈ	ÁÈ KFI ÁÖÈ	ÁÈ KFI ÁÖÈ	ÁÈ KFI ÁÖÈ	ÁÈ KFI ÁÖÈ	ÁÈ KFI ÁÖÈ	ÁÈ KFI ÁÖÈ
É€Á ã • È	€	€	€	ì	€	ì	€
ÉFI Á ã • È	€	€	€	F€	€	F€	1
ÉH€Á ã • È	€	€	€	FF	€	FF	€
Éí Á ã • È	€	€	€	14	€	14	€
Vl cã Á [] { ^	€	€	€	IG	€	IG	F
Á ÁÖÈ] ÈV] cã	€	€	€	F€€	€	Á	GÈ
UPØ	ÈÈÈÈ	ÈÈÈÈ	ÈÈÈÈ	È È €	ÈÈÈÈ	È È €	È È €

Ö| | ~ | • Á | ð | ä | Å | & E
 UU | Ö | ç | Å | F | I
 Ö | | | } ~ | ç | ä | Å | Ö | |
 ç | I | F | Ö | | È | È | I

Ö | ä | Å | - | ç | | } ~ | ç | ä | Å | Ö | |
 P | H | U | Ö | ç | | { | ä | ç | Å | Ö |
 Ö | Y | Å | | ~ | ç | ä | Å | Ö | | ç | ä | Å |
 Y | ^ | ç | ä | Å | Ö | | } ~ |

Ö | ä | Å | | ^ | ç | ä | Å | Ö | | U | Ö |
 U | ä | Å | | ä | ç | | ç | ä | Å | Ö |
 U | ç | ä | Å | Ö | | ç | ä | Å | Ö |
 U | ä | Å | | ç | ä | Å | Ö |

Ö | | | ~ | • Á | | ð | | ä | Å | Ö | • Å | Ö | ç | ä | Å | Ö | | ~ | Å | | & • Å | Ö | ç | ä | Å | Ö | | ~ | Å | | & • Å | Ö | ç | ä | Å | Ö | | ~ | Å | | & •

	Ö { [ä ç Å Ö U ç ä Å Ö } ä			U ^ ç ä Å Ö ^ ç ä Å Ö Y ^ ç ä Å Ö } ä			U ^ ç ä Å Ö ^ ç ä Å Ö Ö ç ä Å Ö } ä			Q ç ä Å Ö
U ç ä Å Ö ^	Š ç	Ü ä Ç	Ö È V ç	V Ö	Ü ä Ç	Ö È V ç	Š ç	V Ö	Ö È V ç	Q ç ä Å Ö
É K È Å Ü T	€	€	€	J I	€	J I	€	F È	F È	È F
É K Í Å Ü T	€	F	F	F È	F	F È	€	F È	F È	È G
É K È Å Ü T	G	€	G	F I G	€	F I G	G	J I	J I	G €
É K Í Å Ü T	€	€	€	F I €	F	F I F	€	F È	F È	G I
V ç	G	F	H	I I J	G	I I F	G	I €	I È	I I
É K È Å Ü T	€	€	€	F I J	F	F J €	F	F F I	F F I	È I
É K Í Å Ü T	F	€	F	F I H	€	F I H	F	F F J	F G È	G I
É K È Å Ü T	F	€	F	F Í	€	F Í	€	F Í I	F Í I	H È
É K Í Å Ü T	€	€	€	F Í F	€	F Í F	€	F Í I	F Í I	È I
V ç	G	€	G	I I I	F	I I J	G	I I I	I I I	F G I
Ö ð ä Å ç	I	F	I	F F Í	H	F F I €	I	J I Í	J I J	G F I
Ö : & Ö Å V ç Å	I €	Ö È	Å	J J È	È H	Å	È È	J J È	Å	Å
U ç ä Å Ö ^	€ G	€	€ G	I È	F	I È	€ G	I È	I È	F G J
Ä Å ç ä Å Ö ^	I €	€	I €	I È	H È	I G È	I €	I G	I F È	I F È
Ö ç ä Å Ö ^ & •	€	€	€	G H	F	G H	€	I H	I H	G I
Ä Å Ö ç ä Å Ö ^ & •	€	€	€	G È	H È	G È	€	I È	I È	F H È
Ö ç ä Å Ö ^ ~ Å Ö ^ & •	€	€	€	I	€	I	€	F H	F H	F J
Ä Å Ö ç ä Å Ö ^ ~ Å Ö ^ & •	€	€	€	È È	€	È È	€	F È	F È	È È
Ö ç ä Å Ö ^ ~ Å Ö ^ & •	€	€	€	G H	€	G H	€	F F I	F F I	H È
Ä Å Ö ç ä Å Ö ^ ~ Å Ö ^ & •	€	€	€	G F	€	G È	€	F G È	F G È	F I
U ç ä Å Ö ^ ~ Å Ö ^ & •	G	F	H	I I	F	I J	G	I G	I I	F I
Ä Å Ö ç ä Å Ö ^ ~ Å Ö ^ & •	I €	F È	I €	I È	H È	I È	I €	I È	I È	I È

	Ö { [ä ç Å Ö U ç ä Å Ö } ä			U ^ ç ä Å Ö ^ ç ä Å Ö Y ^ ç ä Å Ö } ä			U ^ ç ä Å Ö ^ ç ä Å Ö Ö ç ä Å Ö } ä			Q ç ä Å Ö
U ç ä Å Ö ^	Š ç	Ü ä Ç	Ö È V ç	V Ö	Ü ä Ç	Ö È V ç	Š ç	V Ö	Ö È V ç	Q ç ä Å Ö
U ç ä Å Ö ^ Ö ç ä Å Ö ^	€	€	€	189	1	190	1	F F I	F F I	È I
U ç ä Å Ö ^ Å Ö ç ä Å Ö ^	€	€	€	F I H	€	F I H	F	F F J	F G È	G I
U ç ä Å Ö ^ Å Ö ç ä Å Ö ^	F	€	F	F Í	€	F Í	€	164	164	330
U ç ä Å Ö ^ Å Ö ç ä Å Ö ^	€	€	€	F Í F	€	F Í F	€	F Í I	F Í I	È I
V ç Å { ^	G	€	G	I I I	F	I I J	G	I I I	I I I	F G I
Ä Å Ö È V ç	F È	È È	È È	J J È	È È	Å	È È	J J È	Å	Å
U P Ø	È È	È È	È È	È È J I	È È €	È È H	È È	È È G I	È È G I	È H È

Ô[] * ÁY [ã] ä ä ÁQ&E
 UUÁÖ ç ÁFI I
 Ô[] : ä ÖÖÄG I I
 QI F D G I E G I

Ôä Á -Á[] * ÁÖä@
 PDUKÖ{ [ääY ä
 ÖBY KÁ^ } [ç^ääÖ] ^ çää
 Y ^ ää@ : KÁ^ } } ^

ÖY Á p ä ^ KÖÖÖ Ö UÖT Ö
 Üä ÁÖ[ä ^ KÖÖÖÖÖÖF
 Üää ÖÖä KÖÖ Ö Ö EFG
 Üä ^ Á [KÖ

Ô[] ^ ÁÜä ç ä ÖÜä * ^ Á K ^ Ö [] ^

ÜääÖÁ [] ^	Qç{ [ääY ä U[çä] ^ ä			Ü^ [ç^ääÖ] ^ çää Y ^ çä] ^ ä			Ü^ [ç^ääÖ] ^ çää Öä çä] ^ ä			Q çä] ^
	S^c	Üä @	Ö[] ÉV[çä	V@	Üä @	Ö[] ÉV[çä	S^c	V@	Ö[] ÉV[çä	
ÉKÉÁÜT	€	€	€	ïï	€	ïï	€	ïF	ïF	FIJ
ÉKÍ ÁÜT	€	€	€	ïJ	€	ïJ	€	ïJ	ïJ	FH
ÉKÉÁÜT	F	€	F	ïï	€	ïï	F	ïï	ïï	FH
ÉKÍ ÁÜT	€	€	€	ïï	F	ïï	€	ïï	ïï	FI F
V[çä	F	€	F	G F	F	G G	F	G J	GJ€	ï H
ÉKÉÁÜT	€	€	€	J I	€	J I	F	ïï	ï J	Fï H
ÉKÍ ÁÜT	€	€	€	ïï	€	ïï	€	ïF	ïF	Fí I
ÉKÉÁÜT	F	€	F	ïï	€	ïï	€	F G	F G	GFF
ÉKÍ ÁÜT	€	€	€	ï G	€	ï G	€	Fé	Fé	Fí €
V[çä	F	€	F	H G	€	H G	F	H F	H J G	ï F J
Ö[] ä Á [] çä	G	€	G	ï é	F	ï é	G	ïï €	ïï G	F G J G
Ö[] : & Ö []	F € €	€	Á	J J É	€ É G	Á	€ H	J J É	Á	Á
V[çä Á	€ É G	€	€ É G	ïï	€ É F	ïï É	€ É G	ï G É	ï G É	

ÜääÖÁ [] ^	Qç{ [ääY ä U[çä] ^ ä			Ü^ [ç^ääÖ] ^ çää Y ^ çä] ^ ä			Ü^ [ç^ääÖ] ^ çää Öä çä] ^ ä			Q çä] ^
	S^c	Üä @	Ö[] ÉV[çä	V@	Üä @	Ö[] ÉV[çä	S^c	V@	Ö[] ÉV[çä	
Üä Á [] : Ö [] ä Á [] { ÉKÉÁÜT Á ÉKÍ ÁÜT Á Üä Á [] Á										
Üä Á [] : Á [] Ö [] çä Á [] ^ & çä } Ö^ ä * Á ÉKÉÁÜT										
ÉKÉÁÜT	€	€	€	94	€	94	1	ïï	ï J	Fï H
ÉKÍ ÁÜT	€	€	€	ïï	€	ïï	€	ïF	ïF	Fí I
ÉKÉÁÜT	1	€	1	ïï	€	ïï	€	124	124	211
ÉKÍ ÁÜT	€	€	€	ï G	€	ï G	€	Fé	Fé	Fí €
V[çä Á [] ^	F	€	F	H G	€	H G	F	H F	H J G	ï F J
Á [] Ö [] ÉV[çä	F € €	€	Á	F € €	€	Á	€ H	J J É	Á	Á
UP Ø	€ É €	€ € €	€ É €	€ É ï	€ € €	€ É ï	€ É €	€ É ï	€ É J €	€ É G

Ö[] • ÁV[] ä á ÁQ&É
 UUÁÖ[] cÁFI I
 Ö[] () äÖÖÁGII
 QI FÖG i È G I

Öä Á -Á[] * ÁÖä@
 PDUKÖ[] { [äáÁV ä
 ÖBY KÁV[] { c^ääÖ[] ^cääá
 Y ^ää@:KÁV[] } }

Öä ÁPä[] ^ KÖÖÖÖ ÖÜT Ö
 Üä ÁÖ[] ä ^ KÖÖÖÖÖÖF
 ÜcääÖÖä[] KÖÖÖÖÖÖF
 Üä ^Á[] KÖÖÖÖÖÖF

Ö[] • ÁV[] ä á ÁQ&É

ÜcääÁV[] ^	Q[] { [äáÁV ä U[] cÖ[] } ä			Ü[] ^ c^ääÖ[] ^ cääá Y ^ • cä[] } ä			Ü[] ^ c^ääÖ[] ^ cääá Öä cä[] } ä			Q[] cÄV[] cÄ
	Š^c	Üä @	Ö[] ÈV[] cÄ	V@~	Üä @	Ö[] ÈV[] cÄ	Š^c	V@~	Ö[] ÈV[] cÄ	
€K€ÁÜT	€	€	€	FÍ	€	FÍ	€	í	í	G
€KÍ ÁÜT	€	€	€	FI	€	FI	€	FF	FF	G
€K€ÁÜT	€	€	€	H	€	H	€	í	í	I
€KÍ ÁÜT	€	€	€	G	€	G	€	í	í	H
V[] cÄ	€	€	€	JI	€	JI	€	HG	HG	FG
€K€ÁÜT	€	€	€	H	F	H	€	í	í	HU
€KÍ ÁÜT	€	€	€	H	€	H	€	í	í	HU
€K€ÁÜT	€	€	€	HG	€	HG	€	í	í	H
€KÍ ÁÜT	€	€	€	H	€	H	€	í	í	I
V[] cÄ	€	€	€	FHU	F	FI	€	GF	GF	FIF
Ö[] ä á ÁV[] cÄ	€	€	€	GH	F	GH	€	íH	íH	G I
Ö[] : & Ö[]	€	€	€	JJÈ	€È	Á	€	F€€	Á	Á
V[] cÄ	€	€	€	ì FÈG	€ÈH	ì FÈ	€	Fì È	Fì È	

ÜcääÁV[] ^	Q[] { [äáÁV ä U[] cÖ[] } ä			Ü[] ^ c^ääÖ[] ^ cääá Y ^ • cä[] } ä			Ü[] ^ c^ääÖ[] ^ cääá Öä cä[] } ä			Q[] cÄV[] cÄ
	Š^c	Üä @	Ö[] ÈV[] cÄ	V@~	Üä @	Ö[] ÈV[] cÄ	Š^c	V@~	Ö[] ÈV[] cÄ	
€K€ÁÜT	€	€	€	H	1	H	€	í	í	HU
€KÍ ÁÜT	€	€	€	H	€	H	€	í	í	HU
€K€ÁÜT	€	€	€	HG	€	HG	€	í	í	H
€KÍ ÁÜT	€	€	€	38	€	38	€	8	8	46
V[] cÄ	€	€	€	FHU	F	FI	€	GF	GF	FIF
Á Ö[] ÈV[] cÄ	€	€	€	JJÈH	€È	Á	€	F€€	Á	Á
UPØ	€€€	€€€	€€€	ÈFI	€È	ÈGF	€€€	Èíí	Èíí	Èíí

Üä ÁP[] : Ö[] ä á ÁV[] { €K€ÁÜT Á €KÍ ÁÜT Á ÜcääÁV[] -Á
 Üä ÁP[] : Á[] Ö[] cÄ ÁQ[] • ^ & cä[] } ÁV[] ä á ÁQ&É

Ól' } o ÁM |ã, ä, ä, ä, ä, ä
 UUÜÜÜÜÜÜÜÜÜÜ
 Ö: | | } ä, ä, ä, ä, ä, ä
 Q | F, G | I | E | D |

Ö: Ä -Ä | } * Ä ä ä @
 P H U I Q Ü c { [ä ä Ä ä ä
 Ö Y K U A ~ | ç ^ ä ä Ö ~ | ç ä ä
 Y ^ ä ä @ : K U ~ } }

Ö: Ä ä ä ^ K S Ö Ö Ü Ö Ü Ö
 U ä Ä Ö | ä ^ K E E E E E E F
 Ü ä ä Ö ä ä K A B H E D E F G
 Ü ä ^ Ä | K G

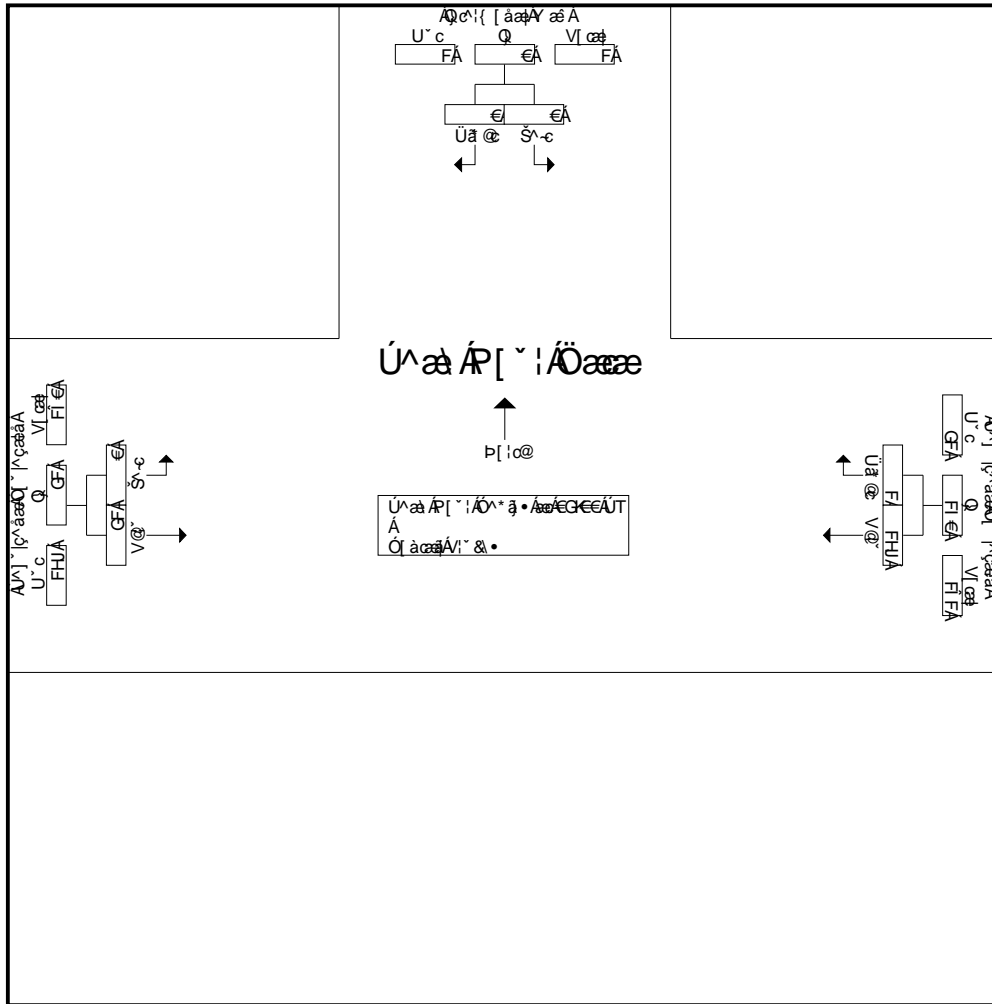

Ú^ ä ä Ä | ~ | I Ö ä ä ä | { Ä G E E Ä Ü T Ä | Ä G K I Ä Ü T Ä Ü ^ ä ä Ä Ä - Ä
 Ú^ ä ä Ä | ~ | Ä | Ö ä ä @ Ü | | ä ä @ ^ ä ä - Ä ä K

	€ G E E Ä Ü T			€ G E E Ä Ü T			€ G E E Ä Ü T		
É È Ä ä ä - È	€	€	€	H	1	H	€		
É F I Ä ä ä - È	€	€	€	H	€	H	€		
É H Ä ä ä - È	€	€	€	H G	€	H G	€		
É I Ä ä ä - È	€	€	€	38	€	38	€	8	8
V I c ä ä { ^	€	€	€	F H U	F	F I €	€	G F	G F
Ä Ä È V c ä ä	€	€	€	J J È H	€ È	Ä	€	F € €	Ä
Ü P Ø	€ € € €	€ € € €	€ € € €	È F I	È €	È G F	€ € € €	È È Ì	È È Ì

Ó[~) , • ÁM | ä ä á Å & Ë
 ÚUÁÓ| c Á F I I
 Ó[() a ä ö Å ð i i
 ç I F D G i Ë Ñ I

Óä: Á - Å [] * Á Ö ä @
 Þ Æ Ú K Ó c [[ä å Á ä
 Ö Y K Á ^] [c ^ ä å Ó | ^ c ä å
 Y ^ ä @ : K Á } } ^

Ö Á Á ä ^ K S Ó Ö Ú Ö T Ö
 Ú ä Á Ö | ä ^ K E E E E E E F
 Ú ä ö Ö ä ^ K G B H E F G
 Ú ä ^ Á | K F

Ö[~] • Á Ú ä c ä ä Ö c ä Á Ú } | Á / ~ & •

Ú ä ö Á / ä ^	Ö c [[ä å Á ä Ú c ä ~ } ä			Ú ^ c ^ ä å Ö ^ c ä å Y ^ • c ä ~ } ä			Ú ^ c ^ ä å Ö ^ c ä å Ö ä c ä ~ } ä			Ö c ä ~ } ä
	Š ^ c	Ü ä @	Ö Æ ç	V @ ~	Ü ä @	Ö Æ ç	Š ^ c	V @ ~	Ö Æ ç	
€ K E Ä Ú T	€	€	€	€	€	€	€	F	F	F
€ K Í Á Ú T	€	€	€	€	€	€	€	F	F	F
€ K H Ä Ú T	€	€	€	F	€	F	€	€	€	F
€ K Í Á Ú T	€	€	€	G	€	G	€	G	G	I
V ç	€	€	€	H	€	H	€	I	I	I
€ G E Ä Ú T	€	€	€	F	€	F	€	H	H	I
€ G K Í Á Ú T	€	€	€	€	€	€	€	I	I	I
€ G K H Ä Ú T	€	€	€	€	€	€	€	F	F	F
€ G K Í Á Ú T	€	€	€	G	€	G	€	F	F	H
V ç	€	€	€	H	€	H	€	J	J	FG
Ö ä ä Á ç	€	€	€	î	€	î	€	FH	FH	FJ
Ö : & @	€	€	€	F€€	€	Á	€	F€€	Á	Á
V ç	€	€	€	H F Ë	€	H F Ë	€	î Ë	î Ë	

Ú ä ö Á / ä ^	Ö c [[ä å Á ä Ú c ä ~ } ä			Ú ^ c ^ ä å Ö ^ c ä å Y ^ • c ä ~ } ä			Ú ^ c ^ ä å Ö ^ c ä å Ö ä c ä ~ } ä			Ö c ä ~ } ä
	Š ^ c	Ü ä @	Ö Æ ç	V @ ~	Ü ä @	Ö Æ ç	Š ^ c	V @ ~	Ö Æ ç	
€ G E Ä Ú T	€	€	€	F	€	F	€	H	H	4
€ G K Í Á Ú T	€	€	€	€	€	€	€	4	4	I
€ G K H Ä Ú T	€	€	€	€	€	€	€	F	F	F
€ G K Í Á Ú T	€	€	€	2	€	2	€	F	F	H
V ç	€	€	€	H	€	H	€	J	J	FG
Á Ö Æ ç	€	€	€	F€€	€	Á	€	F€€	Á	Á
UP Ø	€€€	€€€	€€€	È Í	€€€	È Í	€€€	È Í H	È Í H	È Í €

Ô[˘]•õÁM|ã,ããÀQ&É
UUÁQ)cÁFFI
Ô[˘]i}ã¿OÁD I i
Q I F D G i È d i

Ôã: Á -Á[] * Áõã@
PBUKQc{ [áãÁY æ
OBY KÁU] ˘|ç^áãO ˘ ˘çãää
Y^æ@:KÁU} }} ˘

Qã ÁPã^ KSSÓOQ UÒT Ô
Uã ÁQ] á^ KEEEEEEEF
UãõOÁæ KÁBHDEFG
Uæ^ÁP] KÁG

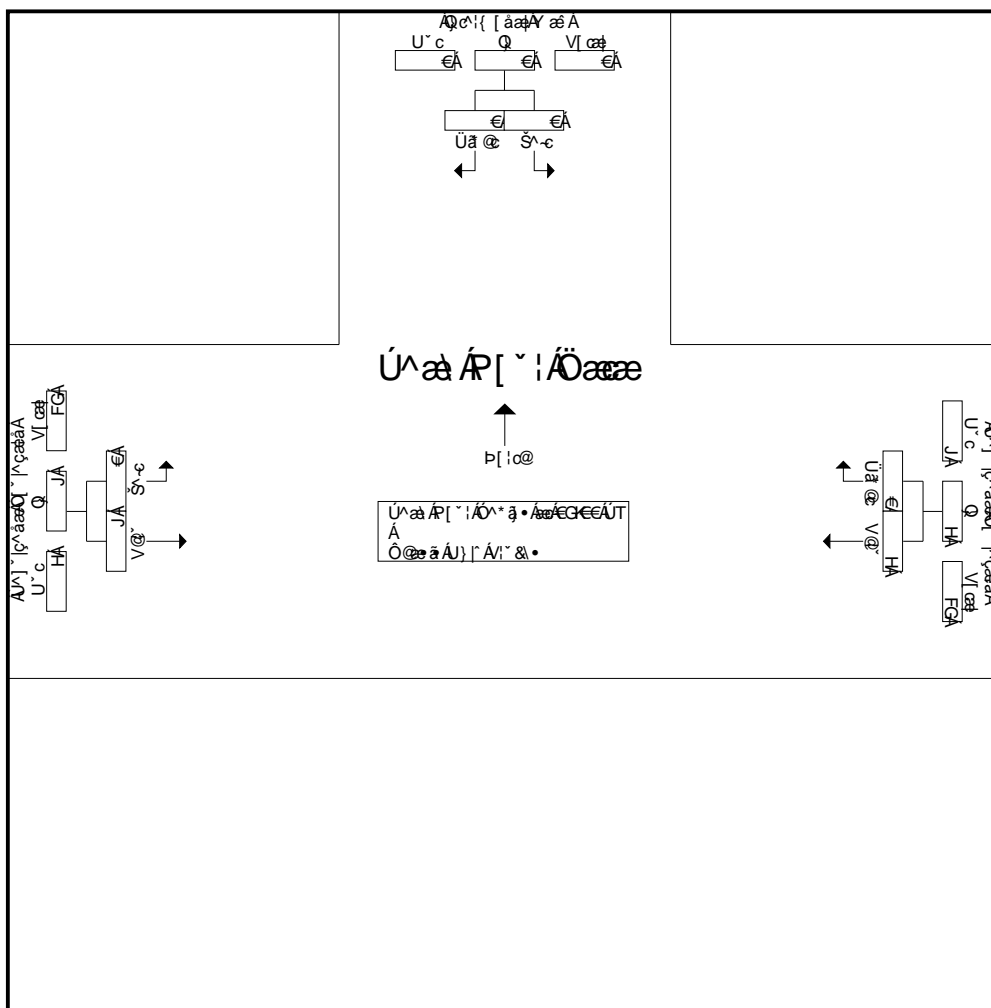

Ú^ãã ÁP[˘ | ÁÖææ • á ÁQ[(ÁEGEEÄT Á ÁEGKI ÁUT ÁÁU^ãã ÁÁÁ -Á
Ú^ãã ÁP[˘ | ÁQ] Oã&OQ] i i] æ@Ö^*ã • ÁæK

	EGEEÄT	EGEEÄT	EGEEÄT	EGEEÄT	EGEEÄT	EGEEÄT	EGEEÄT	EGEEÄT	EGEEÄT	EGEEÄT	EGEEÄT
ÉEÁ ä • È	€	€	€	F	€	F	€	H	H	€	H
ÉFI Á ä • È	€	€	€	€	€	€	€	4	4	€	€
ÉHEÁ ä • È	€	€	€	€	€	€	€	F	F	€	€
Éi Á ä • È	€	€	€	2	€	2	€	F	F	€	€
V[çãK[] ˘ ^	€	€	€	H	€	H	€	J	J	€	€
Á ÁQ] ÁV[çã	€	€	€	FEE	€	Á	€	FEE	Á	€	€
UPØ	BECE	BECE	BECE	ÈÈI	BECE	ÈÈI	BECE	ÈÈH	ÈÈH	BECE	BECE

Ö| | ~ } • ÁV| ä ä ÁQ&É
 UUÁÖ| çÁFÍÍ
 Ö| | | } äÖÖÁGÍÍ
 Q| FÖG| È G|

Öä: Á -Á| } * ÁÖä@
 ÞÖU|KÖ| { [ääY äé
 ÖY KÁ| } | ç^ääÖ| ~ | çäää
 Y ^ ää@: KÁ| } } ^

Öä: Á ä ^ KÖÖÖÖ ÖÖT Ö
 Üä: ÁÖ| ä ^ KÖÖÖÖÖF
 Üää: Öä ^ KÖÖ ÖÖFÖG
 Üä: Á| KÖ

Ö| | ~ } • ÁV| ä ä ÁQ&É | çÁFÍÍ & •

Üää: Á ^	Qç { [ääY äé U çÖ ~ } ä			Ü ~ ç^ääÖ ~ çäää Y ^ • çä ~ } ä			Ü ~ ç^ääÖ ~ çäää Öä çä ~ } ä			Q çÄ çä
	Š^c	Üä @	Ö ÈV çä	V@~	Üä @	Ö ÈV çä	Š^c	V@~	Ö ÈV çä	
€K€ÁÜT	€	€	€	í	€	í	€	FF	FF	FÍ
€KÍ ÁÜT	€	€	€	F€	€	F€	€	F€	F€	Ö€
€K€ÁÜT	€	€	€	G	€	G	€	F€	F€	H
€KÍ ÁÜT	€	€	€	G	€	G	€	FF	FF	H
V çä	€	€	€	íí	€	íí	€	I G	I G	F€J
€K€ÁÜT	€	€	€	íí	€	íí	€	Fí	Fí	íí
€KÍ ÁÜT	€	€	€	íí	€	íí	€	GH	GH	íJ
€K€ÁÜT	€	€	€	I F	€	I F	€	Fí	Fí	íJ
€KÍ ÁÜT	€	€	€	I H	€	I H	€	Fí	Fí	íJ
V çä	€	€	€	Fíí	€	Fíí	€	íí	íí	G F
Ö ä ä ÁV çä	€	€	€	G H	€	G H	€	FFí	FFí	H €
Ö : & ÖÄ	€	€	€	F€€	€	F€€	€	F€€	F€€	Á
V çä Ä	€	€	€	íí È	€	íí È	€	HÖÈ	HÖÈ	

Üää: Á ^	Qç { [ääY äé U çÖ ~ } ä			Ü ~ ç^ääÖ ~ çäää Y ^ • çä ~ } ä			Ü ~ ç^ääÖ ~ çäää Öä çä ~ } ä			Q çÄ çä
	Š^c	Üä @	Ö ÈV çä	V@~	Üä @	Ö ÈV çä	Š^c	V@~	Ö ÈV çä	
Üä: Á ~ Ö ä ä ÁV çä { €K€ÁÜT Ä €KÍ ÁÜT Ä Üä: Á ~ Á										
Üä: Á ~ Á : Ö ç^ääÖ ~ çäää } Ö ä ä ÁV çä										
€K€ÁÜT	€	€	€	46	€	46	€	Fí	Fí	íí
€KÍ ÁÜT	€	€	€	íí	€	íí	€	23	23	69
€K€ÁÜT	€	€	€	I F	€	I F	€	Fí	Fí	íJ
€KÍ ÁÜT	€	€	€	I H	€	I H	€	Fí	Fí	íJ
V çä K } ^	€	€	€	Fíí	€	Fíí	€	íí	íí	G F
Á Ö ÈV çä	€	€	€	F€€	€	F€€	€	F€€	F€€	Á
UPØ	€€€	€€€	€€€	Èíí	€€€	Èíí	€€€	È Fí	È Fí	È €J

Ö[~]•ÁŸ|ä ä•áQ&É
 ÚUÁŸcÁFíí
 Ö[í]•áÖÖáŸíí
 QíFDíÉí

Öä Á-Ÿ[]•ÁÖä@
 ÞEUIÖÖ[]{ [ääŸŸ ä
 ÖEY KÁŸ[]{c^ääÖ[]^cää
 Y^ä@:KÁŸ[]}^

Öä Á-Ÿ[]•ÁÖä@ KÖÖÖÖÖÖÖÖÖÖ
 ÞEUIÖÖ[]{ [ääŸŸ ä KÖÖÖÖÖÖÖÖÖÖ
 ÖEY KÁŸ[]{c^ääÖ[]^cää KÖÖÖÖÖÖÖÖÖÖ
 Y^ä@:KÁŸ[]}^ KÖÖÖÖÖÖÖÖÖÖ

Ö[í]•ÁŸ|ä ä•áQ&É•

	Qö[í]{ [ääŸŸ ä U[]cö[í] }ä			ÚŸ[]{c^ääÖ[]^cää Y^•cä[]}ä			ÚŸ[]{c^ääÖ[]^cää Öäcä[]}ä			
ÚcääÁŸ[]^	Š^c	Üä@	Ö[í]ÉV[]cä	V@~	Üä@	Ö[í]ÉV[]cä	Š^c	V@~	Ö[í]ÉV[]cä	Qö[í]cä
€K€ÁŸ	€	€	€	í	€	í	€	í	í	F€
€Kí ÁŸ	€	F	F	í	F	í	€	J	J	Fí
€K€ÁŸ	F	€	F	F€	€	F€	F	FF	FG	GH
€Kí ÁŸ	€	€	€	FF	€	FF	€	F€	F€	GF
V[]cä	F	F	G	H	F	H	F	H	H	íG
€K€ÁŸ	€	€	€	Fí	€	Fí	€	FF	FF	í
€Kí ÁŸ	F	€	F	í	€	í	F	í	í	Fí
€K€ÁŸ	€	€	€	í	€	í	€	Fí	Fí	GG
€Kí ÁŸ	€	€	€	í	€	í	€	Fí	Fí	GE
V[]cä	F	€	F	H	€	H	F	íí	íJ	íí
Ö[í]•áÁŸ[]cä	G	F	H	íí	F	íJ	G	íG	íí	Fíí
Ö[í]•áÁŸ[]cä	ííÉ	HÉH	Á	JíÉ	FÉ	Á	GÉ	JíÉ	Á	Á
V[]cä	FÉH	ÉÉ	FÉ	íHÉ	ÉÉ	ííÉ	FÉH	íGÉ	íHÉ	

	Qö[í]{ [ääŸŸ ä U[]cö[í] }ä			ÚŸ[]{c^ääÖ[]^cää Y^•cä[]}ä			ÚŸ[]{c^ääÖ[]^cää Öäcä[]}ä			
ÚcääÁŸ[]^	Š^c	Üä@	Ö[í]ÉV[]cä	V@~	Üä@	Ö[í]ÉV[]cä	Š^c	V@~	Ö[í]ÉV[]cä	Qö[í]cä
€K€ÁŸ	€	€	€	14	€	14	€	FF	FF	25
€Kí ÁŸ	1	€	1	í	€	í	1	í	í	Fí
€K€ÁŸ	€	€	€	í	€	í	€	16	16	GG
€Kí ÁŸ	€	€	€	í	€	í	€	Fí	Fí	GE
V[]cä	F	€	F	H	€	H	F	íí	íJ	íí
Á ÁŸ[]ÉV[]cä	F€€	€	Á	F€€	€	Á	G	Jí	Á	Á
UPØ	Éí€	É€€	Éí€	Éí€	É€€	Éí€	Éí€	Éí€	Éí€	Éí€

ÚŸ[]{c^ääÖ[]^cää
Y^•cä[]}ä

ÚŸ[]{c^ääÖ[]^cää
Öäcä[]}ä

Ó[~}oAM|ã.ããAQ&E
 UUÁQ|cAFIi
 Ó[!|]ãÖÖÁGii
 QI FÁi È ð i

Óã Á -Á[]*ÁOã@
 ÞEUIQc{ [ããÁ æ
 ÖEY KÁ^]~|ç^ããÖ|~|çããã
 Y^ãã@:KÁ^}}^

Qã Áãã ^ KÖÖÖQ UÖT Ö
 Úã ÁÖ| á^ KEEEEEEF
 ÚããÖOãã KÁBDEFG
 Úãã^Áã KÁG

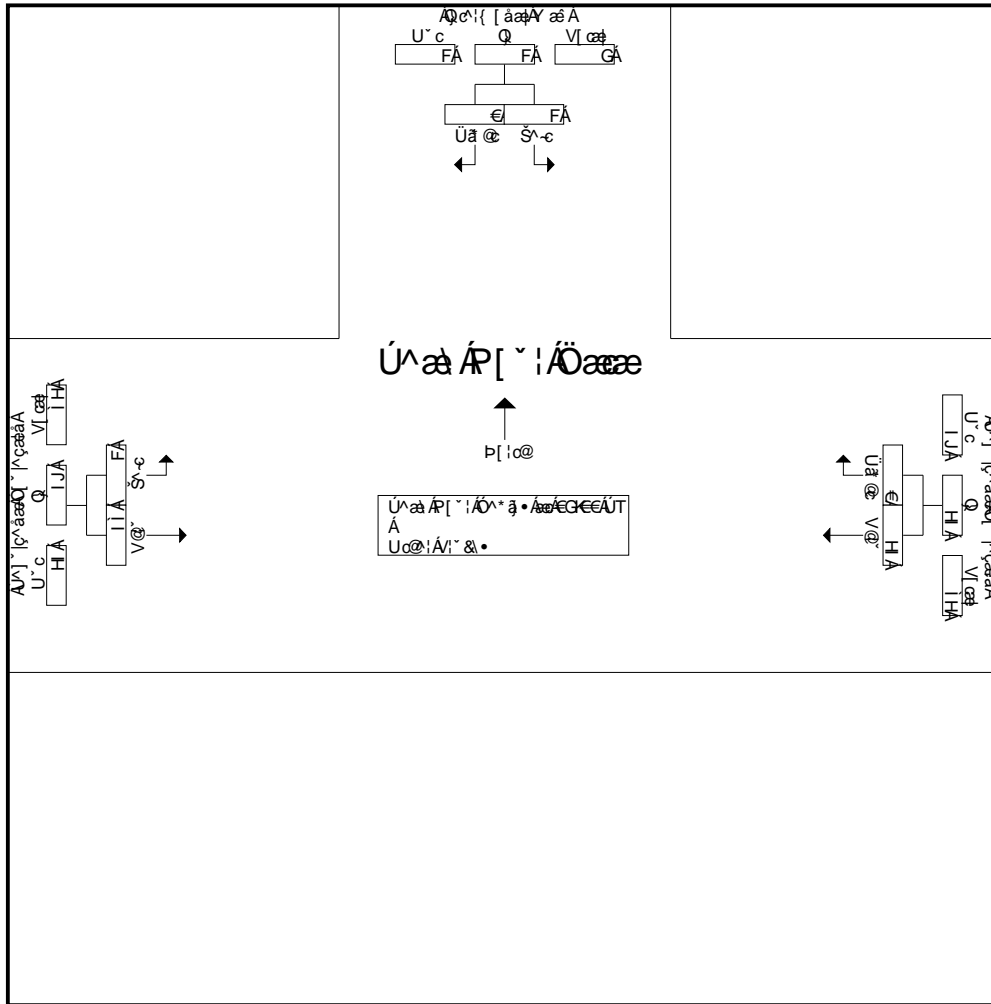

Úãã ÁR[~|ÁÖãã • ÁããEGEEÁUT ÁããEGKÍ ÁUT ÁããÚãã Áãã Áãã
 Úãã ÁR[~|ÁÖãã • ÁããEGEEÁUT ÁããEGKÍ ÁUT ÁããÚãã Áãã Áãã

	EGEEÁUT			EGEEÁUT			EGEEÁUT		
ÉÉÁ ã • È	€	€	€	14	€	14	€	FF	FF
ÉFÍ Á ã • È	1	€	1	ì	€	ì	1	ì	16
ÉHEÁ ã • È	€	€	€	î	€	î	€	16	16
ÉI Í Á ã • È	€	€	€	î	€	î	€	FI	FI
V cããK] { ^	F	€	F	H	€	H	F	Iì	I J
Á ÁÖ ÈV cãã	FEE	€	Á	FEE	€	Á	G	Jì	Á
ÚPØ	€	€	€	È È	€	È È	€	È È	È È

Ó{ } • ÁM | á á á Á Q & E
 UUÁQ c Á F I I
 Ó{ | } á á á Á G I I
 Q I F Á G I I E G I

Óá Á - Á { } * Á Q á @
 P B U K Q c { [á á Á á
 O E Y K Á U } { ç ^ á á Á { } ^ ç á á
 Y ^ á á @ : K Á } } }

Q á Á P á ^ K S Ó Q U Ó Ú T
 Ú á Á Q | á ^ K E E E E E E F
 U á á Á Q á ^ K G H E F G
 Ú á ^ Á P | K G

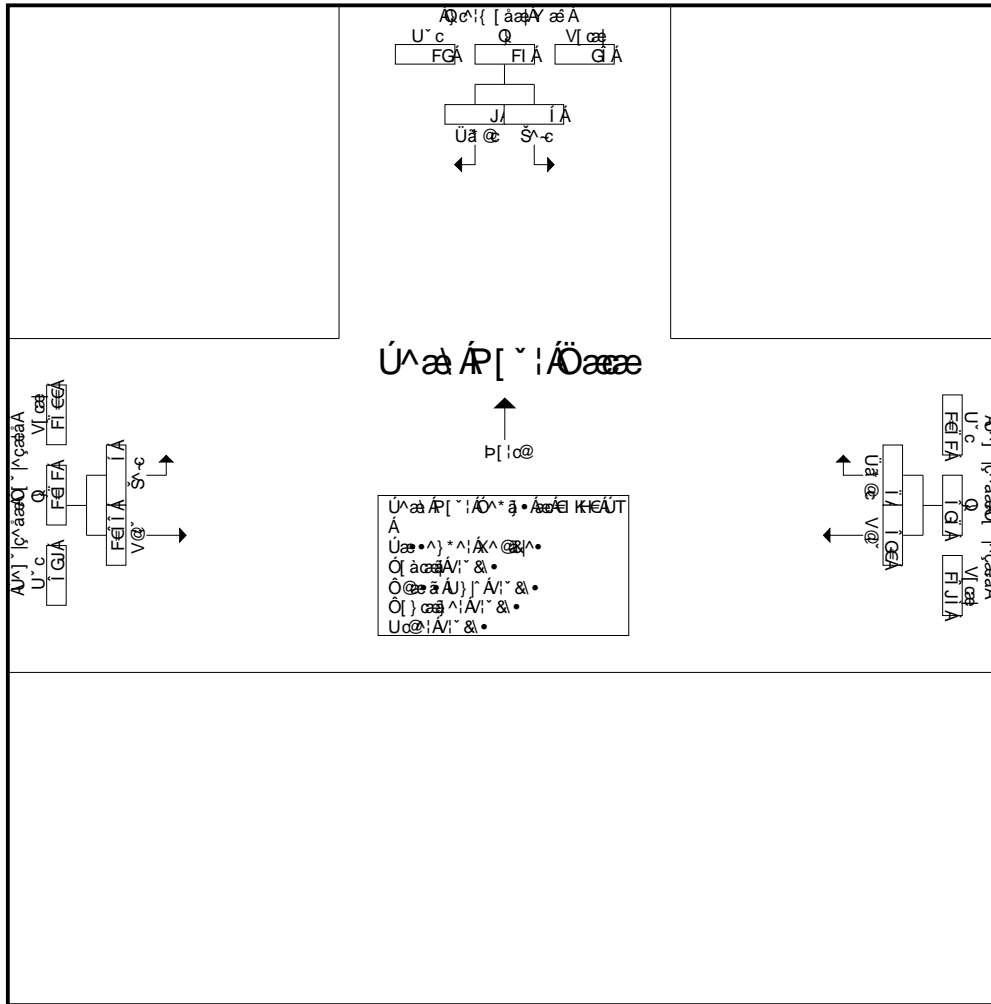

Ú á á Á P [~ | Á Ö á á • á Á { } Á K K E Á Ú T Á Á K I Á Ú T Á U á á Á Á Á Á
 Ú á á Á P [~ | Á Ö á á Q I } | á á @ Á * á • Á á K

	€ K E Á Ú T			€ K I Á Ú T			€ K E Á Ú T		
É É Á á • É	3	€	H	F I í	F	F I ï	2	G í	G í
É F I Á á • É	G	3	5	F I í	5	F I J	F	G G	G H
É H E Á á • É	G	F	H	F I í	G	F I ï	G	G í	G í
É I Á á • É	F	H	I	174	€	174	€	295	295
V ~ ç á á K I } { ^	í	í	F I	í H E	í	í H	í	F E í	F E F
Á Á Q E V ç á	í H E	í í E	Á	J I E	F E H	Á	€	J J E	Á
Ú P Ø	E í	E í H	E í €	E í	E í €	E í	E í G	E í H	E í

Ö [~] • Á V [ä] ä á Á Q & E
 UU Á Ö ç Á F I I
 Ö [()] ä á Ö ç Á G I I
 Q I F D G I Æ G I

Ö ä Á - Å [~] * Á Ö ä @
 P E U K Ö ç [~] { [ä ä Á Y ä
 Ö Y K Á V [~] ç ^ ä ä Ö [~] ç ä ä
 Y ^ ä @ : K Á } } }

Ö ä Á ç ^ K S Ö Ö Ö U Ö U T
 U ä Á Ö [ä ^ K E E E E E E F
 Ö ç Ö Ö ä K G H E D E F G
 U ä ^ Á [K F

Ö [~] • Á V [ä] ä á Á Q & E

Ü ç Ö Á V [ä] ^	Q ç [~] { [ä ä Á Y ä U [~] ç [~] } ä			Ü [~] ç ^ ä ä Ö [~] ç ä ä Y ^ • ç [~] } ä			Ü [~] ç ^ ä ä Ö [~] ç ä ä Ö ä ç [~] } ä			Q ç V [ç]
	Š ^ c	Ü ä @	Ö [] È V [ç]	V @ ~	Ü ä @	Ö [] È V [ç]	Š ^ c	V @ ~	Ö [] È V [ç]	
É K E Á U T	€	€	€	F E G	€	F E G	€	F I J	F I J	G F
É K I Á U T	F	F	G	J G	€	J G	€	G È	G È	H E G
É K E Á U T	€	F	F	F E H	€	F E H	€	G G H	G G H	H G
É K I Á U T	F	€	F	J I	€	J I	€	G F F	G F F	H F E
V [ç]	G	G	I	H J I	€	H J I	€	I F F	I F F	F G F E
É K E Á U T	F	€	F	F H U	€	F H U	€	G H F	G H F	H F
É K I Á U T	€	€	€	F È	€	F È	€	G G	G G	H I
É K E Á U T	€	€	€	F F F	€	F F F	€	G G	G G	H I
É K I Á U T	€	€	€	J F	€	J F	€	F I I	F I I	G I
V [ç]	F	€	F	I I I	€	I I I	€	I I H	I I H	F H E
Ö [ä] ä Á V [ç]	H	G	I	I I F	€	I I F	€	F I J I	F I J I	G I €
Ö [] : & Ö Á	I €	I €	Á	F E E	€	Á	€	F E E	Á	Á
V [ç] Á	È È	È È	È G	H È	€	H È	€	I I È	I I È	

Ü ç Ö Á V [ä] ^	Q ç [~] { [ä ä Á Y ä U [~] ç [~] } ä			Ü [~] ç ^ ä ä Ö [~] ç ä ä Y ^ • ç [~] } ä			Ü [~] ç ^ ä ä Ö [~] ç ä ä Ö ä ç [~] } ä			Q ç V [ç]
	Š ^ c	Ü ä @	Ö [] È V [ç]	V @ ~	Ü ä @	Ö [] È V [ç]	Š ^ c	V @ ~	Ö [] È V [ç]	
Ü ä Á V [~] : Ö ç [~] • ä Á V [~] { [ä E K E Á U T Á E K I Á U T Á V ä Á V [~] - Á										
Ü ä Á V [~] : Á [~] Ö ç [~] • ä Á V [~] { [ä E K E Á U T										
É K E Á U T	€	1	1	F E H	€	F E H	€	G G H	G G H	H G
É K I Á U T	1	€	F	J I	€	J I	€	G F F	G F F	H F E
É K E Á U T	F	€	F	139	€	139	€	G H F	G H F	371
É K I Á U T	€	€	€	F È	€	F È	€	252	252	H I
V [ç] X [~] ^	G	F	H	I I I	€	I I I	€	J F I	J F I	F H I
Á Ö [] È V [ç]	I I È	H È H	Á	F E E	€	Á	€	F E E	Á	Á
U P Ø	È €	È €	È I €	È €	È €	È €	È €	È F E	È F E	È G E

Ô[~ } • ÁM |ã. äããQ&E
 UUÁQ cAFIi
 Ô[!|} äÖÖÁGii
 QI FÖG i È ð i

Ôã Á -Á[] * ÁÖã@
 ÞEUIQ c{ [äãY äe
 ÖEY KÁ^] [ç^ äãÖ [~ |çãää
 Y ^ äã@ : KÁ } } }

Öã Á pã ^ KÖÖÖÖ ÖÚÓÚT
 Úã ÁÖ [ä ^ KEEEEEEEF
 ÚããÖ Öãã KÖÖÖ HDEFG
 Úãã ^ Á [KÁG

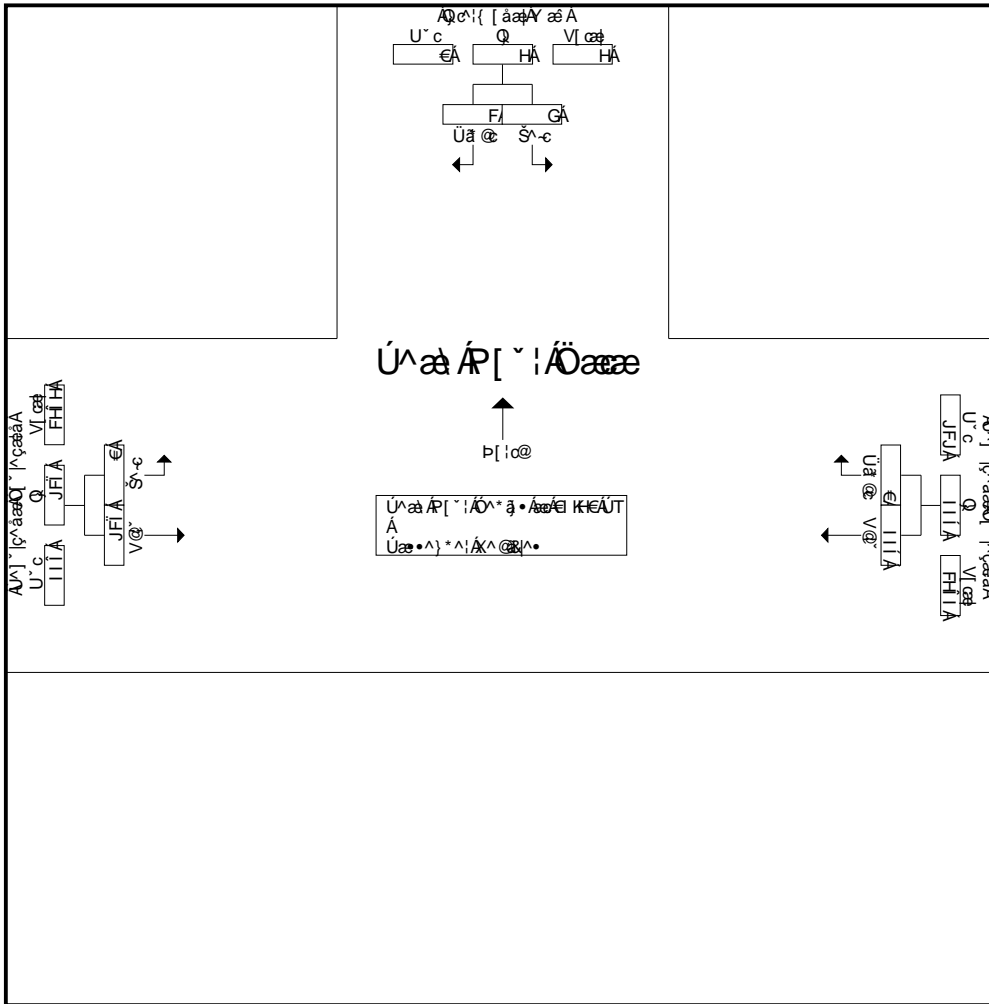

Ú^ äã ÁR [~ | ÁÖ äãæ • ä ÁÖ [(ÁE KHEÚT ÁE ÁE KHE ÚT ÁE Ú^ äã ÁR Á - Á
 Ú^ äã ÁR [~ | ÁÖ äãæ ÖÚ [] : äã ÖÚ ^ ä • ÁãK

	Ei KHEÚT			Ei KHEÚT			Ei KHEÚT		
ÉÉÁ ä • È	€	1	1	FEH	€	FEH	€	GGH	GGH
ÉFÍ Á ä • È	1	€	F	Ji	€	Ji	€	GFF	GFF
ÉHEÁ ä • È	F	€	F	139	€	139	€	GHF	GHF
Éi Á ä • È	€	€	€	Féi	€	Féi	€	252	252
Vj çãX [] { ^	G	F	H	III	€	III	€	JFí	JFí
Á ÁÖ [] E V [çã	î î È	H ÈH	Á	FEE	€	Á	€	FEE	Á
UPØ	È €€	È €	È í €	È €€	È€€€	È €€	È€€€	ÈF€	ÈF€

Ó[~ } o ÁM |ã. ããÁQ&É
 UUÁQ c ÁFFII
 Ó[! |] ããÁQÁGII
 QI FÁGII ÈGÍ

Óã Á -Á[] * ÁCã@
 PDUKQ c { [ããÁ ãé
 OBY KÁU } |ç^ããÁQ | ^ çããá
 Y ^ãã@: KÁU } }

Qã Á pã ^ KÁSOÓQ ÚÓÚT
 Úã Á Q | á ^ KÁEEEEEFF
 ÚããÁQãã KÁGBHDEF G
 Úãã Á p | KÁG

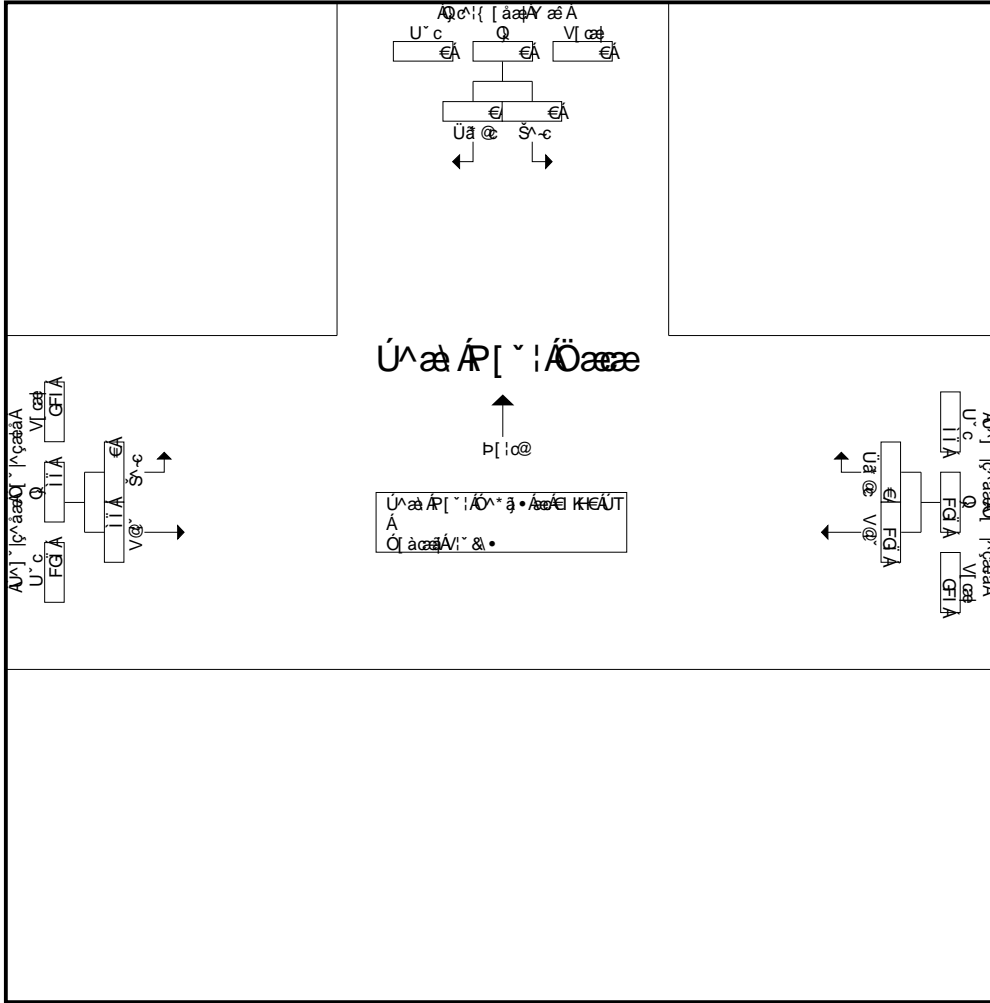

Úãã Á P[~ | ÁQãã. ÁããÁ { ÁKÁËÚT ÁKÁËÚT ÁKÁËÚT ÁKÁËÚT ÁKÁËÚT ÁKÁËÚT
 Úãã Á P[~ | ÁKÁËÚT ÁKÁËÚT ÁKÁËÚT ÁKÁËÚT ÁKÁËÚT ÁKÁËÚT ÁKÁËÚT

	€ KÁËÚT			€ KÁËÚT			€ KÁËÚT		
É€Á ã • È	€	€	€	H	€	H	€	24	24
ÉFÍ Á ã • È	€	€	€	41	€	41	€	GG	GG
ÉH€Á ã • È	€	€	€	G	€	G	€	FÍ	FÍ
ÉI Á ã • È	€	€	€	G	€	G	€	GH	GH
V çãÁK] { ^	€	€	€	FG	€	FG	€	II	II
Á ÁQ] EV çã	€	€	Á	FEE	€	Á	€	FEE	Á
ÚPØ	€€€	€€€	€€€	È II	€€€	È II	€€€	È€	È€

Ö[]•ÁV[]á áÁQ&É
 UUÁÖ[]ÁFÍ
 Ö[]ááÖÖÁGÍ
 QI FÖG I È G I

Öá Á -Á[]•ÁÖá@
 ÞÖU[]Ö[]{ [ááÁ á
 ÖY KÁ[]{ [ááÁÖ[] Áçáá
 Y ^áá@:KÁ[]}}^

Öá Á á ^ KÖÖÖÖÖÖÖÖÖÖÖÖ
 Üá ÁÖ[] á ^ KÖÖÖÖÖÖÖÖÖÖÖÖ
 ÜááÖÖá KÖÖÖÖÖÖÖÖÖÖÖÖ
 ÜááÁ[] KÖÖÖÖÖÖÖÖÖÖÖÖ

Ö[]•ÁV[]á áÁQ&É

	Ö[]{ [ááÁ á U[]Ö[]}á			Ü[]{ [ááÁ á Y ^•á[]}á			Ü[]{ [ááÁ á Öáá[]}á			
ÜááÁ[] ^	Š^c	Üá @	Ö[] ÈV[] Ö	V@	Üá @	Ö[] ÈV[] Ö	Š^c	V@	Ö[] ÈV[] Ö	Q ÖV[] Ö
É KÉÁÜT	G	€	G	FÍ	F	FÍ	G	F€	FG	HF
É KÍ ÁÜT	F	F	G	FÍ	F	FÍ	€	J	J	G
É KÉÁÜT	G	€	G	F€	Í	FÍ	G	FÍ	FÍ	H
É KÍ ÁÜT	€	H	H	FÍ	G	FÍ	F	í	í	G
V[] Ö	Í	I	J	ÍÍ	J	ÍÍ	Í	I€	ÍÍ	FFJ
É KÉÁÜT	F	F	G	H	€	H	G	J	FF	FÍ
É KÍ ÁÜT	€	I	I	Í	€	Í	€	FI	FI	GH
É KÉÁÜT	G	€	G	I	€	I	F	FF	FG	FÍ
É KÍ ÁÜT	G	F	H	Í	€	Í	F	í	J	FÍ
V[] Ö	Í	Í	FF	FÍ	€	FÍ	I	IG	ÍÍ	ÍÍ
Ö[] áÁ[] Ö	F€	F€	G€	ÍI	J	ìH	J	ìG	JF	FJI
Ö[] :&Ö	Í€	Í€	Á	ìJÈ	FèÈ	Á	JÈ	JèÈ	Á	Á
V[] Ö	ÍÈ	ÍÈ	FèÈ	H È	I È	I È	I È	I È	I È	

	Ö[]{ [ááÁ á U[]Ö[]}á			Ü[]{ [ááÁ á Y ^•á[]}á			Ü[]{ [ááÁ á Öáá[]}á			
ÜááÁ[] ^	Š^c	Üá @	Ö[] ÈV[] Ö	V@	Üá @	Ö[] ÈV[] Ö	Š^c	V@	Ö[] ÈV[] Ö	Q ÖV[] Ö
ÜááÁ[] :&Ö	Í€	Í€	Á	ìJÈ	FèÈ	Á	JÈ	JèÈ	Á	Á
ÜááÁ[] :Á[] Ö	ÍÈ	ÍÈ	FèÈ	H È	I È	I È	I È	I È	I È	
É KÉÁÜT	2	€	G	F€	5	FÍ	2	15	17	34
É KÍ ÁÜT	€	H	H	14	G	16	F	í	í	G
É KÉÁÜT	F	F	G	H	€	H	G	J	FF	FÍ
É KÍ ÁÜT	€	4	4	Í	€	Í	€	FI	FI	GH
V[] Ö	H	Í	FF	HG	Í	HJ	Í	II	IJ	JJ
Á Ö[] ÈV[] Ö	G È	Í È	Á	ì È	F È	Á	F È	ì È	Á	Á
UPØ	È Í	È €	È Í	È Í	È €	È €	È G	È H	È G	È G

Ô[~ } • ÁM jã ããÁQ&É
UUÁQ cÁFfi
Ô[!:] æÁQ&G i i
QI F&G i È ð i

Ôã Á -Á[] * ÁQ&@
P&UjKQ c! { [áãÁ æ
OËY KÁU] ~ [ç^áãÁQ ~ ^çãää
Y ^æ@:KÁU" } }

Qã Ápã ^ K&SÓQ&ÙÓÚT
Uã ÁQ[á^ K&E&E&E&E&E&E&E&F
UããÁQ&æ K&G&H&E&F&G
Uã ^ Áp[K&G

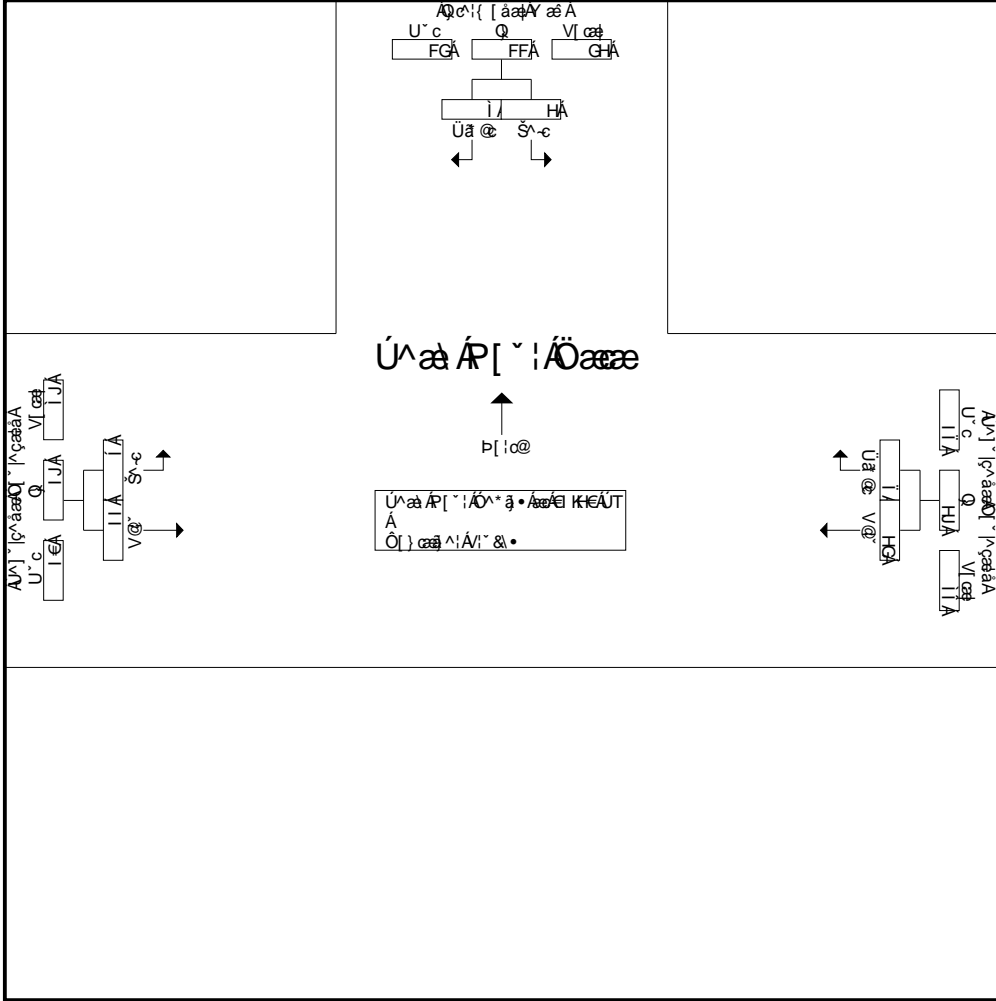

Ú^æá ÁP[~ | ÁÖææ * Á ÁP[(Ái K&EÚT Ái Ái K&I ÁÚT ÁEÚ^æá ÁÁ -Á
Ú^æá ÁP[~ | ÁÖææ Q[] ! : áãÁQ&G i i : æÁQ&G i i * Á ÁK

	€i K&EÚT			€i K&EÚT			€i K&EÚT		
ÉÉÁ á • È	2	€	G	F€	5	Fí	2	15	17
ÉFí Á á • È	€	H	H	14	G	16	F	í	í
ÉHÉÁ á • È	F	F	G	H	€	H	G	J	FF
Éí Á á • È	€	4	4	í	€	í	€	FI	FI
Ví çãÁK[] { ^	H	í	FF	HG	í	HJ	í	II	IJ
Á ÁQ[] ÈV[] çã	G ÈH	í GÈ	Á	í GÈ	Fí È	Á	F€G	í JÈ	Á
ÚPØ	Èí í	Èí €	Èí i	Èí F	Èí €	Èí €	Èí G	Èí H	Èí G

Ó[~]·ÁÁ|ã á·ÁQ&É
 ÚUÁÓ cÁFIÍ
 Ó[~]·ÁÁ|ã á·ÁQ&É
 QI FDI Ë GI

Óã Á -Á[]·ÁQ&@
 PDUKQc: { [áãÁ æ
 OBY KÁ^ } |ç^áãÓ | ^çãá
 Y ^æ@:KÁ^ } } ^

Qã ÁPã ^ K&ÓÓQ ÚÓÚT
 Úã ÁÓ | á^ K&E&E&E&E&E F
 Úã ÓÓæ K&G&H&E&F&G
 Úã ^Á | K&F

Öi[~]·ÁÚã ç·áÉUc@:Á/Í·&·

	Qc: { [áãÁ æ U ç@ } á			Ú^ ç^áãÓ ^çãá Y ^·çá } á			Ú^ ç^áãÓ ^çãá Oæ çá } á			Q çÁ çæ
ÚçãÁ/ã ^	Š^c	Üã @	Q[] ÉV çæ	V@~	Üã @	Q[] ÉV çæ	Š^c	V@~	Q[] ÉV çæ	Q çÁ çæ
É K&ÉÚT	F	€	F	í	€	í	€	G	G	F€
É KÍ ÁÚT	€	F	F	l	€	l	F	H	l	J
É K&ÉÚT	€	€	€	H	€	H	€	G	G	í
É KÍ ÁÚT	€	€	€	G	€	G	€	G	G	l
V çæ	F	F	G	Fí	€	Fí	F	J	F€	G
É K&ÉÚT	€	€	€	í	€	í	€	l	l	J
É KÍ ÁÚT	€	€	€	G	€	G	€	l	l	í
É K&ÉÚT	€	€	€	G	€	G	€	í	í	í
É KÍ ÁÚT	€	€	€	F	€	F	€	í	í	í
V çæ	€	€	€	F€	€	F€	€	FJ	FJ	GJ
Ó[] áÁ çæ	F	F	G	G	€	G	F	G	GJ	í í
Q[] : & @	í €	í €	Á	F€€	€	Á	HÉ	Jí È	Á	Á
V çæ	FÈ	FÈ	HÈ	í í È	€	í í È	FÈ	l J È	í € È	

	Qc: { [áãÁ æ U ç@ } á			Ú^ ç^áãÓ ^çãá Y ^·çá } á			Ú^ ç^áãÓ ^çãá Oæ çá } á			Q çÁ çæ
ÚçãÁ/ã ^	Š^c	Üã @	Q[] ÉV çæ	V@~	Üã @	Q[] ÉV çæ	Š^c	V@~	Q[] ÉV çæ	Q çÁ çæ
Úã ÁP ~ Á[] ç·á·áÁ { ÁÉ K&ÉÚT ÁÉ KÍ ÁÚT ÁÚã ÁÁ -Á										
Úã ÁP ~ Á[] ç·á·áÁ { ÁÚã ÁÁ -Á										
É K&ÉÚT	€	€	€	H	€	H	€	G	G	í
É KÍ ÁÚT	€	€	€	G	€	G	€	G	G	l
É K&ÉÚT	€	€	€	5	€	5	€	4	4	9
É KÍ ÁÚT	€	€	€	G	€	G	€	l	l	í
V çæ	€	€	€	FG	€	FG	€	FG	FG	G
Á ÁQ ÉV çæ	€	€	Á	F€€	€	Á	€	F€€	Á	Á
UP Ø	È€€	È€€	È€€	È €€	È€€	È €€	È€€	È í €	È í €	È í í

Ó[~}•ÁM|á.ããÁQ&É
 UUÁQ|cÁFII
 Ó[!|]ããÁQ&É
 Q|FÁQ|ÉÉ|

Óã Á -Á[]*Á^ãã@
 ÞEYKÓEã ^ããÁUd^^c
 ÓEY KÁãããÁQ|ããÁ@ããÁUã]
 Y^ãã@!KÁ" } } ^

Óã Áã ^ KÖÓÓÖSÚÓPÜCÉ
 Úã ÁQ|ã^ KÉÉÉÉÉÉ F
 ÚããÁQãã KÖÖJHDEFG
 ÚããÁQ| KÖ

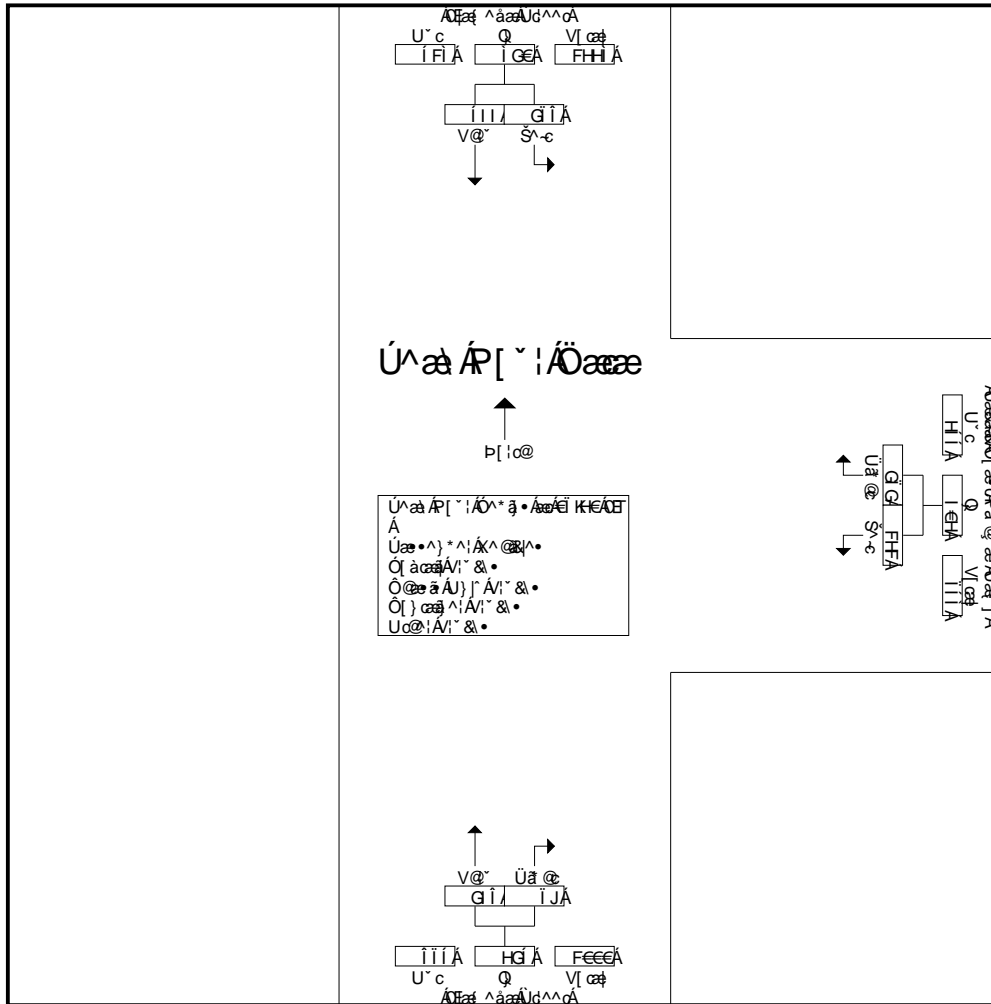

Úã ÁR[~|ÁQãã•ãÁQ|{ Áí KÉÁÉ Áí Áí KÉ ÁÉ ÁU^ã ÁÁ Á-Á
 Úã ÁR[~|Á| ÁQãã@Q|!|ãã@Á^ã•ÁãK

	Éí KÉÁÉ			Éí KÉÁÉ			Éí KÉÁÉ		
ÉÉÁ á•É	89	149	238	HH	91	124	íí	22	ìJ
ÉFí Á á•É	íí	F F	GFJ	37	íG	FÉJ	í€	FJ	ìJ
ÉHÁ á•É	íí	FH	Géí	HH	íH	íí	íí	Fí	íí
Éí Á á•É	IG	FFí	Fíí	G	íí	íí	81	G€	101
V cãK] { ^	Gí	ííí	íGé	FHF	G G	íEH	Gí	íJ	HG
Á ÁQ ÉV cã	HÉ	ííÉH	Á	HGÉ	ííÉ	Á	ííÉ	G ÉH	Á
UPØ	Éíí	ÉFH	ÉíF	Éíí	Éíí	ÉFH	ÉíJ	ÉJí	Éé

Ó[~]·ÁŸ|ã ä·áÁ&É
 ÚÚÁÓ|çÁFÍÍ
 Ó[~]·áŸÓçÁGíí
 QÍ FĐG í È G í

Óã Á-Á[~]·ÁŸ·áã@
 ÞÞÍKÓÇä ^áãÁÚd^^c
 ÖËY KÁŸáãÁÓ[æ óPã @ æ ÁÚä]
 Y ^áã@:KÁŸ } } }

Ç^ ÁPä ^ KÖÓÓçSÚÓPÚçÞ
 Úã ÁÓ| ä^ KÉÉÉÉÉ F
 ÚççóÓçä KÇBUBDFG
 Úã ÁP[KÇ

Ó[~]·ÁŸ|ã ç·áÁŸ·^)*·Á|Á^@·
 Y ^·çá[~]·á

ÚççóÁŸ ^	Çäç ^áãÁÚd^^c Ú[~]·çá[~]·á			ÚáãáÁÓ[æ óPã @ æ ÁÚä] Y ^·çá[~]·á			Çäç ^áãÁÚd^^c P[~]·çá[~]·á			Q çá[~]·á
	Š^·c	V@~	Ç[~] ÈV[çä]	Š^·c	Úã @	Ç[~] ÈV[çä]	V@~	Úã @	Ç[~] ÈV[çä]	
È KÉÁÇÞ	IJ	ÍÍ	FFI	FJ	ÍÉ	ÍJ	G	Í	H	GF
È KÍ ÁÇÞ	ÍÍ	ÍH	FGJ	J	ÍÍ	ÍÍ	G	Í	HG	GFÍ
È KÉÁÇÞ	ÍÉ	FFG	FJG	GH	ÍJ	FEG	HU	FF	ÍÉ	HÍ
È KÍ ÁÇÞ	ÍJ	FFF	FÍÉ	HF	ÍÍ	JÍ	G	FF	H	HFI
V[çä]	GÍ	HÍ	ÍFÍ	IG	G F	HGH	FFI	HÍ	FÍH	FÉJÍ
È KÉÁÇÞ	ÍÉ	JG	FÍG	G	ÍÍ	ÍF	ÇÉ	Í	G	GHU
È KÍ ÁÇÞ	G	ÍH	FÉF	GG	ÍÉ	ÍG	ÍÍ	FH	ÍÍ	GHE
È KÉÁÇÞ	HH	ÍÍ	JJ	FJ	IG	ÍF	FÍ	FG	HÉ	FJÉ
È KÍ ÁÇÞ	ÍÉ	ÍÍ	ÍÍ	FJ	HF	ÍÉ	HÉ	FG	IG	FÍÉ
V[çä]	FÍF	GJ	ÍHÉ	ÍÍ	FÍÍ	GÍ	FFG	ÍH	FÍÍ	ÍHU
Ó[~]·áÁ[çä]	ÍÉ	ÍH	FÉÍ	FÍÍ	ÍÉ	ÍÍ	GHE	ÍÍ	HÉ	FJHH
Ç[~]·:;&ÇÄ	HÍ È	ÍFÈ	Á	GJÈ	ÍÉÈ	Á	ÍÍÈ	G ÈÈ	Á	Á
V[çä]	G	HÈ	ÍÍÈ	ÍÈ	G FÈ	GJÈ	FFÈ	Í	FÍÈ	

ÚççóÁŸ ^	Çäç ^áãÁÚd^^c Ú[~]·çá[~]·á			ÚáãáÁÓ[æ óPã @ æ ÁÚä] Y ^·çá[~]·á			Çäç ^áãÁÚd^^c P[~]·çá[~]·á			Q çá[~]·á
	Š^·c	V@~	Ç[~] ÈV[çä]	Š^·c	Úã @	Ç[~] ÈV[çä]	V@~	Úã @	Ç[~] ÈV[çä]	
È KÉÁÇÞ	80	112	192	GH	79	102	HU	FF	ÍÉ	344
È KÍ ÁÇÞ	ÍJ	FFF	FÍÉ	31	ÍÍ	JÍ	G	FF	H	HFI
È KÉÁÇÞ	ÍÉ	JG	FÍG	G	ÍÍ	ÍF	ÇÉ	Í	G	GHU
È KÍ ÁÇÞ	G	ÍH	FÉF	GG	ÍÉ	ÍG	44	13	57	GHE
V[çä]	GG	HÍ	ÍFÍ	FEG	G F	HÍH	FG	ÍF	FÍJ	FFG
Á Ç[~] ÈV[çä]	HÍ È	ÍHÈ	Á	GJÈ	ÍÉÈ	Á	ÍÍÈ	G ÈÈ	Á	Á
UPØ	ÈÉ	ÈÍ	ÈÉF	ÈGH	ÈÍH	ÈÍF	ÈG	ÈÍ	ÈÍF	ÈFJ

Úã ÁP[~]·:;&ÇÄ { È| KÉÁÇÞ È| KÍ ÁÇÞ ÈÚã ÁP[~]·F
 Úã ÁP[~]·:;&ÇÄ } ÁŸ·áã·ÁŸ·^)*·Á|Á^@· È| KÉÁÇÞ

Ó[~}•ÁM|ãããÁQ&É
 UUÁQ]cÁFII
 Ó[!|]ããÁQ&É
 QI FÁQI ÈÉI

Óã Á -Á[]*Á^ãã@
 ÞEYKÓEã ^ããÁUd^^c
 ÖEY KÁãããÁQ]ããÁ @ããÁUã]
 Y^ãã@:KÁ" } } ^

Qã Áã ^ KÖÖÖÖÖÖÖÖÖÖÖÖ
 Úã ÁQ]ã^ KÉÉÉÉÉÉÉ F
 ÚããÁQãã KÖÖÖÖÖÖÖÖÖÖ
 ÚããÁQ] KÖ

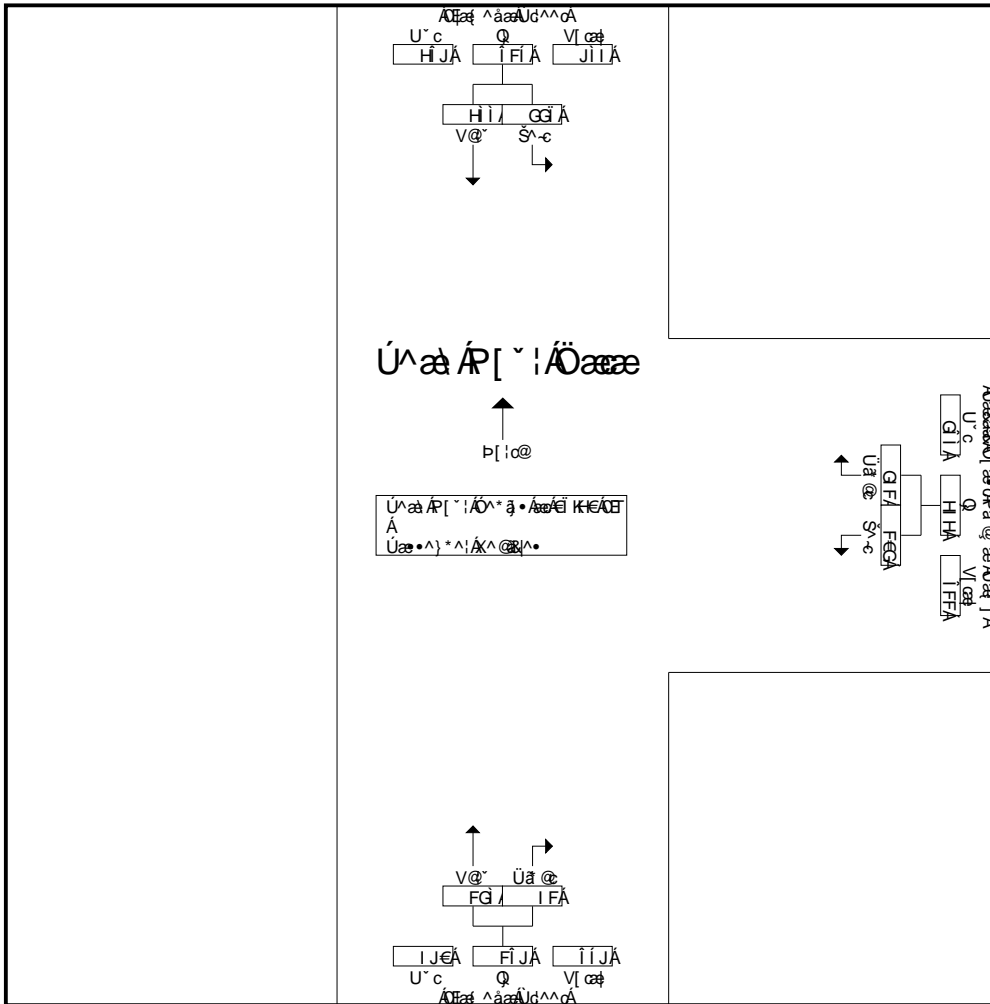

Ú^ãã ÁR[~!ÁQãã•ãÁQ] { ÁI KÉÁQ ÁI ÁI KÉÁQ ÁU^ãã ÁRÁ-Á
 Ú^ãã ÁR[~!ÁQãã@Q]!|ãã@Ö^ãã•ÁãK

	ÉI KÉÁQ			ÉI KÉÁQ			ÉI KÉÁQ		
ÉÉÁ ã•È	80	112	192	GH	79	102	HU	FF	í€
ÉFÁ ã•È	îJ	FFF	Fí€	31	íí	Jì	G	FF	H
ÉHÁ ã•È	í€	JG	FIG	G	í	ÏF	Q€	í	G
ÉIÁ ã•È	G	ÏH	F€F	GG	í€	ÏG	44	13	57
V[cããK] { ^	GQ	HÏ	ÏFí	FEG	G F	H H	FG	IF	FíJ
Á ÁQ] ÈV[cãã	H È	Ï È	Á	GJÈ	í €H	Á	í í È	G ÈH	Á
UPØ	È€	Èí	È€F	ÈGH	ÈíH	ÈíF	ÈG	Èí	ÈíF

Ö[]•ÁV|ã ä^ÁQ&É
 UUÁÖ cÁFIÍ
 Ö[] äÖÖÁGÍÍ
 QI FÖG I È G I

Öä Á -Á[]*Á^ã@
 ÞÖUÍKÖFä ^ããÁÜd^^c
 ÖEY KÁÜããÁÖ[ä öP ä @ ä ÁÜä]
 Y ^ã@:KÁ } } }

Ö^ Á ä ^ KÖÖÖÖÖÖÖÖÖÖÖÖÖÖÖÖ
 Üä ÁÖ[ä^ KÉÉÉÉÉÉ F
 Ücä Öäã KÖÖÖÖÖÖÖÖÖÖÖÖÖÖÖÖ
 Üä ^ Á [KÖ

Ö[]•ÁV|ã ä^ÁQ&É äãÁV|ã &•

Ücä ÖÁV ã ^	ÖFä ^ããÁÜd^^c U cÖ[] ä			ÜããÁÖ[ä öP ä @ ä ÁÜä] Y ^•cä[] ä			ÖFä ^ããÁÜd^^c P[:cÖ[] ä			Q cÄV cä
	Š^c	V@~	Ö[] ÈV cä	Š^c	Üä @	Ö[] ÈV cä	V@~	Üä @	Ö[] ÈV cä	
È KÉÁÖF	F	FH	FI	G	€	G	F€	F	FF	G
È KÍ ÁÖF	F	í	í	I	F	í	í	í	F€	GF
È KÉÁÖF	€	í	í	H	H	í	G	í	F€	GG
È KÍ ÁÖF	F	í	í	H	€	H	G	í	í	FÍ
V cä	H	H€	HH	FG	I	FÍ	FJ	FJ	H	IÍ
È KÉÁÖF	I	í	F€	H	€	H	I	G	í	FJ
È KÍ ÁÖF	í	GF	G	H	€	H	Fí	F	FJ	IÍ
È KÉÁÖF	G	FG	FI	í	í	FG	H	G	í	HF
È KÍ ÁÖF	€	FÍ	FÍ	F	I	í	J	H	FG	HG
V cä	FF	íI	íí	FH	F€	GH	H	í	IG	FHE
Ö[] ä ÁV cä	FI	íI	Jí	G	FI	HU	íH	G	í€	GÍ
Ö[] :&ÖÁ	FI ÈH	íí ÈÈ	Á	íí ÈÈ	Hí ÈÈ	Á	íí ÈÈ	HÈÈ	Á	Á
V cä Á	íÈÈ	Hí ÈÈ	Ií ÈÈ	FFÈÈ	íÈÈ	Fí	G ÈÈ	FGÈÈ	Hí ÈÈ	

Ücä ÖÁV ã ^	ÖFä ^ããÁÜd^^c U cÖ[] ä			ÜããÁÖ[ä öP ä @ ä ÁÜä] Y ^•cä[] ä			ÖFä ^ããÁÜd^^c P[:cÖ[] ä			Q cÄV cä
	Š^c	V@~	Ö[] ÈV cä	Š^c	Üä @	Ö[] ÈV cä	V@~	Üä @	Ö[] ÈV cä	
È KÉÁÖF	€	í	í	3	3	6	G	8	F€	GG
È KÍ ÁÖF	F	í	í	H	€	H	G	í	í	FÍ
È KÉÁÖF	I	í	F€	H	€	H	I	G	í	FJ
È KÍ ÁÖF	5	21	26	H	€	H	18	F	19	48
V cä K[] ^	F€	HU	IJ	FG	H	FÍ	G	FÍ	IG	F€
Á Ö[] ÈV cä	GÈÈ	íJÈÈ	Á	í€	G€	Á	íFÈÈ	Hí ÈÈ	Á	Á
UPØ	È€€	ÈíI	ÈíF	FÈ€	È€	ÈG	ÈíF	È€€	ÈíH	ÈíG

Üã ÁP[] :&ÖÁ { ÁÈ KÉÁÖF ÁÈ KÍ ÁÖF ÁÜã ÁV|ã ÁF
 Üã ÁP[] :Á[] Ö[] ä ÁV|ã :&ÖÁ } Á^* ä • ÁÈ KÉÁÖF

Ó[^] o ÁM |ã äãÁQ&E
 UUÁQ] cÁFfI
 Ó[!:] äáÖÖÁG I i
 Q! FÁG i È G i

Óã Á -Á[] * Á^ã@
 ÞEUKIÖEä ^ããÁUd^^c
 ÖEY KÁUãããÁÖ[ä öPã @ äãÁUä]
 Y ^ã@:KÁU''}}

Qã ÁPã ^ KÖÖÖÖÖÖÖÖÖÖÖ ÖPÜÇE
 Úã ÁÖ[ä^ KÉÉÉÉÉÉÉÉÉÉÉÉ F
 Úã ö Öãã KÖBJRDEFG
 Úã ÁP[KÖ

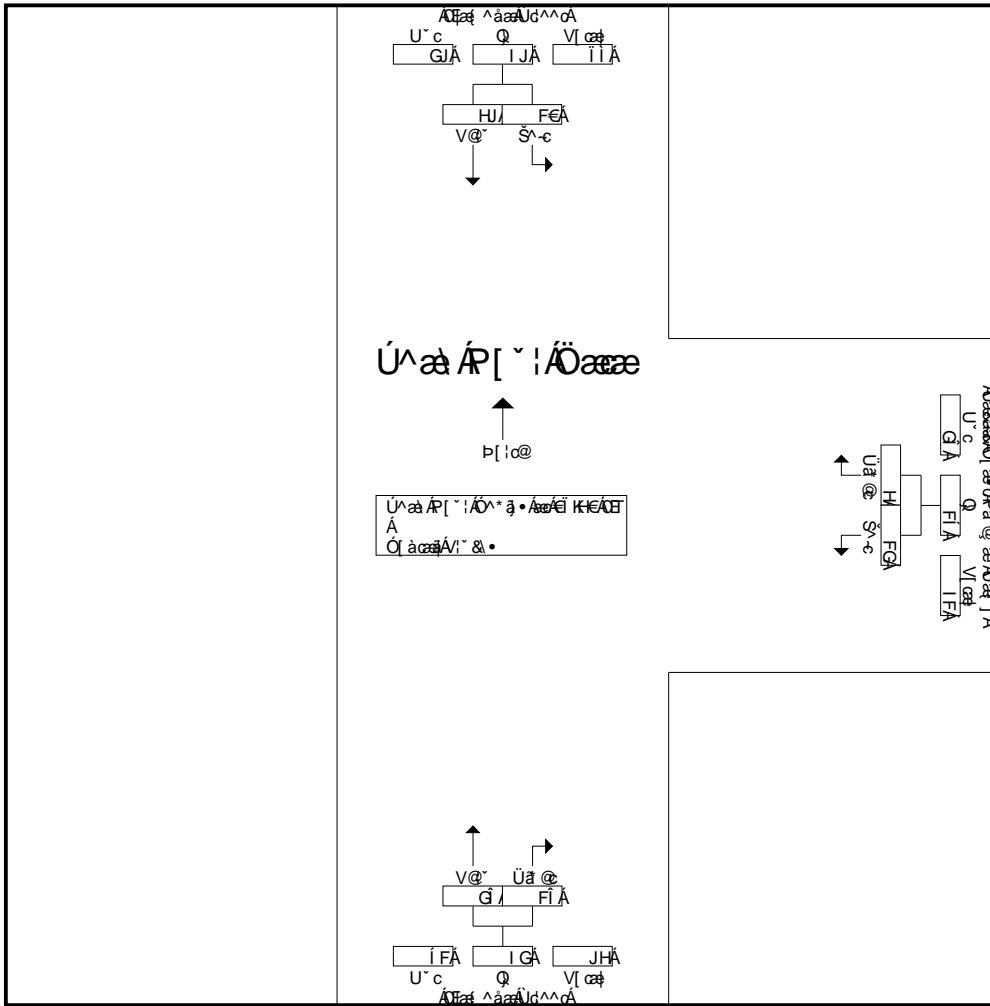

Úã ÁP[^! ÖÖäæ * ä ÁÖ[] Ái KÉÁÇE Ái Ái KÉÁÇE ÁU^ã ÁFÄ -Á
 Úã ÁP[^! Á[Öä@Ö[]! ä äÖ^ ä * ÁãK

	€ KÉÁÇE			€ KÉÁÇE			€ KÉÁÇE		
ÉÉÁ ä • È	€	î	î	3	3	6	G	8	F€
ÉFÍ Á ä • È	F	î	î	H	€	H	G	í	î
ÉHÉ Á ä • È	I	î	F€	H	€	H	I	G	î
ÉÍ Á ä • È	5	21	26	H	€	H	18	F	19
V[cãÁ[] { ^	F€	HJ	I J	FG	H	FÍ	G	FÍ	I G
Á ÁÖ[] ÉV[cã	ÖEÈ	Í JÈ	Á	ì €	ÖE	Á	î FÈ	H È	Á
UPØ	È €€	È Í I	È Í F	FÈ€€	È €	È G	È Í F	È €€	È Í H

Ö[~]•ÁM|ã ä^ÁQ&É
 ÚUÁÖ|çÁFÍÍ
 Ö[!:]ãÖÖãGÍÍ
 QÍFÖGíÈGÍ

Öã Á-Á[]*Á^ã@
 ÞEUIKÖã ^ããÁÜd^^c
 ÖEY KÁãããÁÖ[æ öPã @ æ ÁÜã]
 Y ^ã@:KÁ } } }

Ö^ Áã ^ KÖÖÖSÜÖPÜÖE
 Úã ÁÖ[ä^ KÉÉÉÉÉ F
 Üã öÖã KÖBUBDFG
 Üã ^Á[K

Ö[~]•ÁÜã çãÉÖ çã ÁÜ } Á/ ~ & •

Üã öÁ/ã ^	Öã ^ããÁÜd^^c U[~]çã[~]ã			ÚãããÁÖ[æ öPã @ æ ÁÜã] Y ^•çã[~]ã			Öã ^ããÁÜd^^c P[!:]çã[~]ã			Q çã[~]ã
	Š^c	V@~	Ö[] ÈV[] çã	Š^c	Üã @	Ö[] ÈV[] çã	V@~	Üã @	Ö[] ÈV[] çã	
È KÉÁÖE	€	€	€	€	€	€	F	€	F	F
È KÍ ÁÖE	€	€	€	€	€	€	F	€	F	F
È KÉÁÖE	€	H	H	€	€	€	F	F	G	Í
È KÍ ÁÖE	€	€	€	€	€	€	F	F	G	G
V[] çã	€	H	H	€	€	€	I	G	Í	J
È KÉÁÖE	G	I	Í	€	€	€	H	F	I	F€
È KÍ ÁÖE	€	€	€	€	€	€	€	€	€	€
È KÉÁÖE	€	€	€	€	€	€	€	€	€	€
È KÍ ÁÖE	€	G	G	€	F	F	G	€	G	Í
V[] çã	G	Í	Í	€	F	F	Í	F	Í	FÍ
Ö!ã äÁ[] çã	G	J	FF	€	F	F	J	H	FG	G
Ö[] !:&ÖÁ	FÍ ÈG	Ì FÈ	Á	€	F€€	Á	ÍÍ	G	Á	Á
V[] çãÁ	Í ÈH	H Í È	Í Í È	€	I ÈG	I ÈG	H Í È	FGÈ	Í €	

Üã öÁ/ã ^	Öã ^ããÁÜd^^c U[~]çã[~]ã			ÚãããÁÖ[æ öPã @ æ ÁÜã] Y ^•çã[~]ã			Öã ^ããÁÜd^^c P[!:]çã[~]ã			Q çã[~]ã
	Š^c	V@~	Ö[] ÈV[] çã	Š^c	Üã @	Ö[] ÈV[] çã	V@~	Üã @	Ö[] ÈV[] çã	
È KÉÁÖE	€	H	H	€	€	€	F	1	G	Í
È KÍ ÁÖE	€	€	€	€	€	€	F	F	G	G
È KÉÁÖE	2	4	6	€	€	€	3	F	4	10
È KÍ ÁÖE	€	€	€	€	€	€	€	€	€	€
V[] çãK[] ^	G	Í	J	€	€	€	Í	H	I	FÍ
Á Ö[] ÈV[] çã	GFG	ÍÍ È	Á	€	€	Á	Í GÈ	H Í È	Á	Á
UPØ	ÈG €	ÈH	ÈÍ	È€€€	È€€€	È€€€	ÈFÍ	ÈÍ €	È€€	ÈG

Úã äÁ[] !:&ÖÁ { È KÉÁÖE È KÍ ÁÖE È ÁÜã äÁ-Á
 Úã äÁ[] !:&ÖÁ çã ÁÖ çã ^ãã } ÁÖ*ã • Áã È KÉÁÖE

Ó[] ÁM |á àáÁQ&É
 UUÁQ| cÁFÍÍ
 Ó[]|] áÁÖÁGíí
 Qí FÁGí É Gí

Óá Á -Á[] *Á^áá@
 ÞÁUíKíQí ááÁUd^^c
 ÖY KÁáááÁÖí ááÁ @ áÁUá]
 Y ^áá@:KÁ" }}^

Qá Á á ^ KÖÖÖÖÖÖÖÖÖÖ ÖPÜÖF
 Úá ÁÖí á ^ KÉÉÉÉÉÉ F
 Úáá Öáá KÖÖÖÖÖ ÖPÜÖF
 Úáá Á [KÖ

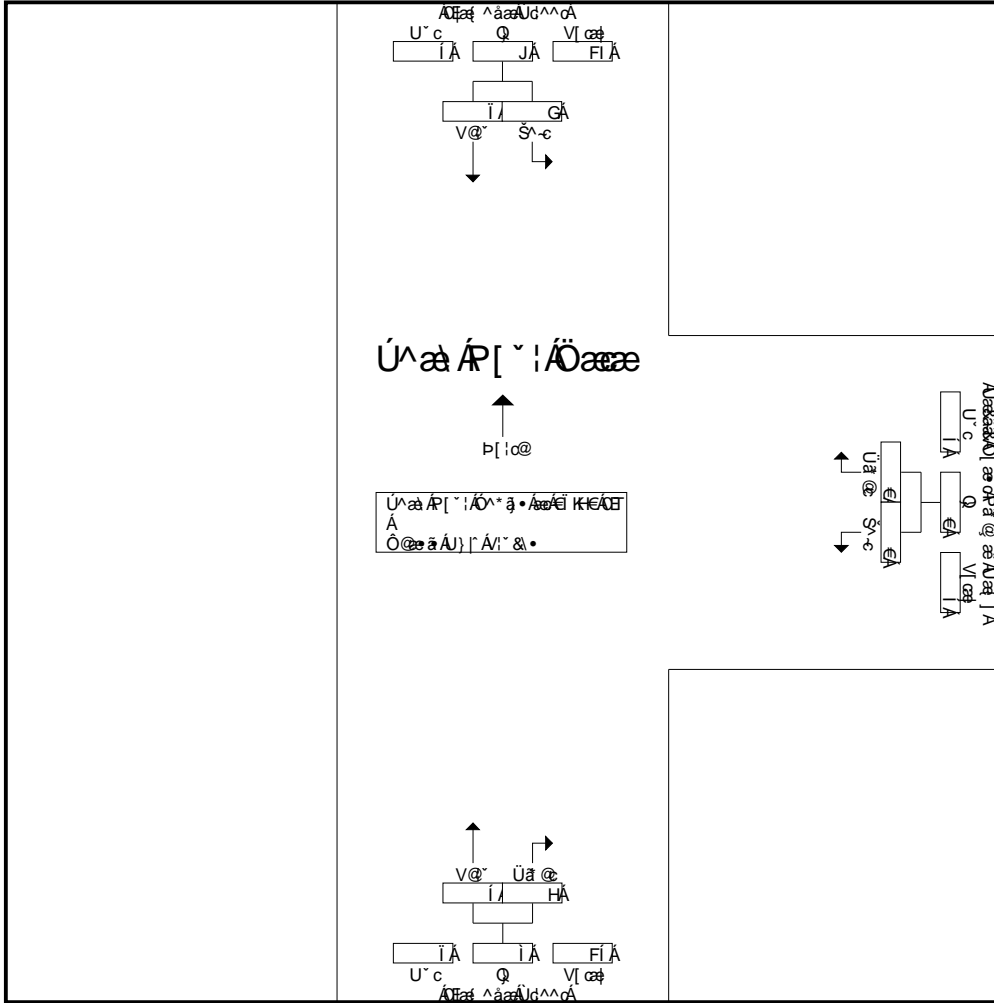

Úáá ÁP[~ | ÁÖ á • ÁÁ [(Áí KíKíÖF Áí Áí KíKíÖF ÁÁ Úáá Á Á -Á
 Úáá ÁP[~ | Áí ÁÖááÖí] |] áá@Á^ á • ÁáK

	Éí KíKíÖF			Éí KíKíÖF			Éí KíKíÖF		
ÉÉÁ á • É	€	H	H	€	€	€	F	1	G
ÉFí Á á • É	€	€	€	€	€	€	F	F	G
ÉHÁ á • É	2	4	6	€	€	€	3	F	4
Éí Á á • É	€	€	€	€	€	€	€	€	€
V cáKí] { ^	G	í	J	€	€	€	í	H	í
Á ÁÖí ÉV cá	GGG	ííÉ	Á	€	€	Á	í Gí	Hí É	Á
UPØ	Éí €	Éí H	Éí í	ÉÉÉÉ	ÉÉÉÉ	ÉÉÉÉ	Éí Fí	Éí €	Éí €€

Ö[] • Á | ä ä Ä & E
 UUÁÖ cÄFI
 Ö[] ä ÖÖÄGII
 QI FDI È G I

Öä Ä -Ä[] * Ä^ ä@
 ÞEJKEÄ ^ ä ä Ä d^ c
 ÖEY KÄ ä ä Ö[ä ö P ä @ ä Ä ä]
 Y ^ ä @ : KÄ } }

Öä Ä ä ^ KÖÖÖÜÖPÜÖE
 Üä Ä[ä ^ KEEEEÉ F
 Ü ä ö Ö ä KGBJ BDFG
 Ü ä Ä [KÄ

Ö[] • Ä | ä c ä Ö[] ä Ä | Ä | & •

Ü ä ö Ä ^	Öä Ä ä d^ c U[cÄ[] ä			Ü ä ä Ö[ä ö P ä @ ä Ä ä] Y ^ cÄ[] ä			Öä Ä ä d^ c P[cÄ[] ä			Q cÄ[]
	Š^ c	V@^	Ö[] ÈV[]	Š^ c	Ü ä @	Ö[] ÈV[]	V@^	Ü ä @	Ö[] ÈV[]	
È KÈÄE	F	í	í	€	F	F	í	í	F€	FJ
È KÍ ÄE	F	F€	FF	€	€	€	FF	F	FG	GH
È KÈÄE	€	FG	FG	F	€	F	FI	€	FI	G
È KÍ ÄE	G	Fí	Fí	€	€	€	FF	G	FH	HE
V[]	I	II	Ií	F	F	G	IG	í	IJ	JJ
È KÈÄE	H	GH	G	€	€	€	í	í	FI	I€
È KÍ ÄE	G	FG	FI	F	€	F	í	í	FG	G
È KÈÄE	F	Fí	Fí	F	€	F	F€	í	FI	HF
È KÍ ÄE	F	FH	FI	H	F	I	J	í	Fí	HH
V[]	í	íH	í€	í	F	í	Hí	Ö€	íí	FHF
Ö[] ä Ä[]	FF	F€í	FFí	í	G	í	íí	G	F€í	GHE
Ö[] : & ÖÄ	JÈH	J€È	Á	íí	G	Á	íí	G	Á	Á
V[] cÄÄ	I È	Ií È	í FÈH	GÈ	€È	HÈ	HÈÈ	FFÈÈ	íí ÈÈ	

Ü ä ö Ä ^	Öä Ä ä d^ c U[cÄ[] ä			Ü ä ä Ö[ä ö P ä @ ä Ä ä] Y ^ cÄ[] ä			Öä Ä ä d^ c P[cÄ[] ä			Q cÄ[]
	Š^ c	V@^	Ö[] ÈV[]	Š^ c	Ü ä @	Ö[] ÈV[]	V@^	Ü ä @	Ö[] ÈV[]	
È KÈÄE	€	FG	FG	1	€	1	14	€	14	G
È KÍ ÄE	G	Fí	Fí	€	€	€	FF	G	FH	HE
È KÈÄE	3	23	26	€	€	€	í	6	FI	40
È KÍ ÄE	G	FG	FI	F	€	F	í	í	FG	G
V[] cÄ[] ^	í	íG	íJ	G	€	G	IF	FG	íH	FG
Ä Ä[] ÈV[]	F€È	íJÈ	Á	F€€	€	Á	ííÈÈ	GÈÈ	Á	Á
UPØ	ÈíH	ÈíI	ÈíH	È€€	È€€	È€€	ÈHG	È€€	ÈíI	ÈíI

Ü ä Ä P[] : & Ä[] ä Ä[] { Ä KÈÄE Ä KÍ ÄE Ä Ü ä Ä Ä - Ä
 Ü ä Ä P[] : Ä[] : & Ä[] c Ä Ä c : ^ & Ä[] Ä * ä • Ä Ä KÈÄE

Ó[~ } , o ÁM |ã, äããQ&É
 UUÁQ] cÁFFI
 Ó[!|] äãÖÖÁG I i
 QI FÁG I È G I

Óã Á -Á[] * ÁO^ãã@
 ÞEUIKÓEã ^ããÁUd^^c
 ÖEY KÁUãããÁO[äãÓPã @ äãÁUã]
 Y ^ãã@:KÁU" } } ^

Qã ÁPã ^ KÖÖÖÖÖÖÖÖÖÖÖÖÖÖÖÖ
 Úã ÁO[ä^ KÉÉÉÉÉÉÉ F
 ÚããÓÖãã KGBJHDEFG
 Úãã ÁP[KÖ

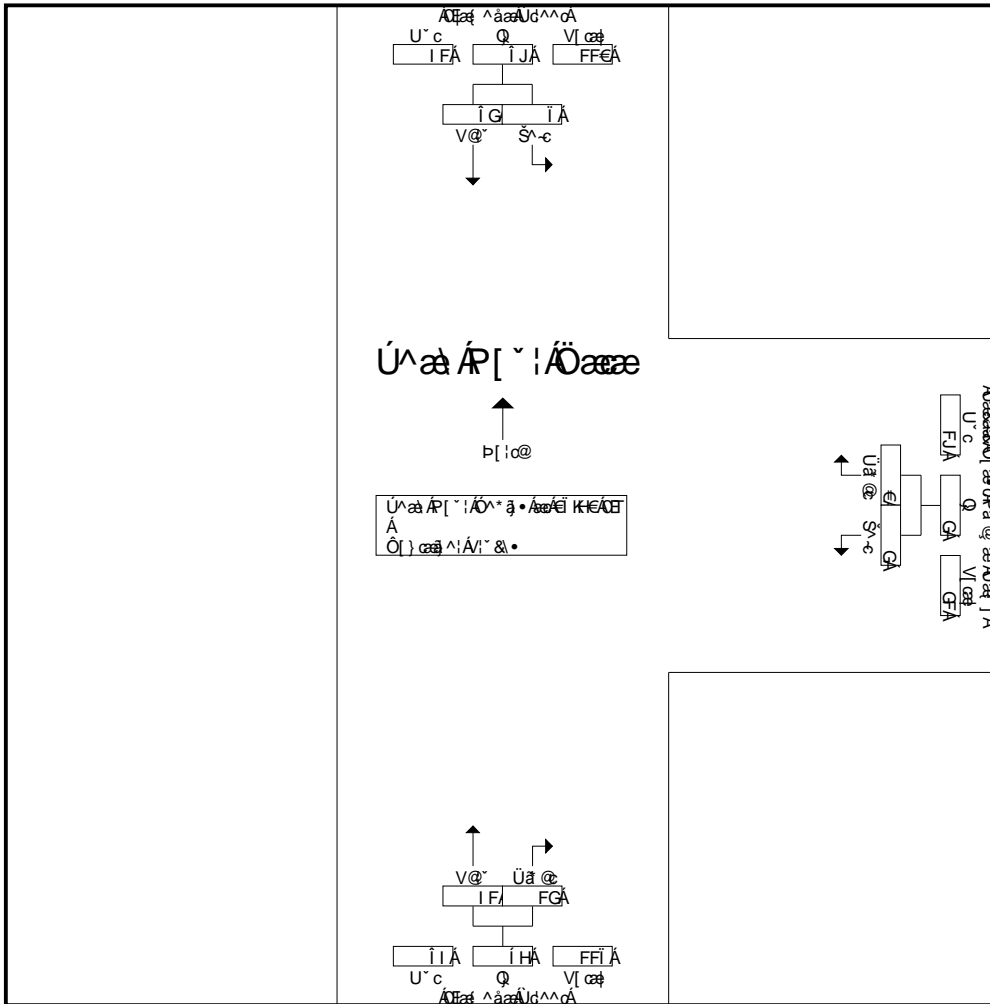

Úãã ÁP[~ ! ÁÖããæ * ä ÁO[! | ÁE KÉÁÖE ÁE ÁE KÉ ÁÖE ÁE Úãã ÁP[~ ÁE
 Úãã ÁP[~ ! ÁE ÁÖããæ QI]! | äã@Ö^ã * ÁãK

	EÍ KÉÁÖE			EÍ KÉÁÖE			EÍ KÉÁÖE		
EÉÁ ä • È	€	FG	FG	1	€	1	14	€	14
ÉFÍ Á ä • È	G	FÍ	FÍ	€	€	€	FF	G	FH
ÉHÁ ä • È	3	23	26	€	€	€	i	6	FI
ÉI Á ä • È	G	FG	FI	F	€	F	i	I	FG
V/cãK[] { ^	I	I G	I J	G	€	G	I F	FG	I H
Á ÖE] E V] cã	F€E	i JÈ	Á	F€€	€	Á	iiÈ	G€E	Á
UØ	È I H	È I I	È I H	È €€	È €€€	È €€	È È G	È €€	È I I

Ö[~]•ÁM|ã ä^ÁQ&É
 ÚUÁÖ cÁFÍÍ
 Ö[~]•áÖÖÁGÍÍ
 QÍFDGÍÉGÍ

Öä Á-Á[~]•Á^á@
 ÞHÍKÖä ^ááÁÜd^^c
 ÖEY KÁáááÁÖ[ä öP ä @ ä ÁÜä]
 Y ^á@:KÁ[~]•

Ö^ ÁPä ^ KÖÖÖÖÖÖÖÖÖÖÖÖ
 Úä ÁÖ[ä^ KÉÉÉÉÉÉ F
 Úcä öÖä KÖÖÖÖÖÖÖÖÖÖÖÖ
 Úä ^ ÁP[KÖ

Ö[~]•ÁÜä c^áÜc@:Á/Í^&•

ÚcäöÁ/ã ^	Öä ^ááÁÜd^^c U[~]c@[~]•á			ÚáááÁÖ[ä öP ä @ ä ÁÜä] Y ^•cá[~]•á			Öä ^ááÁÜd^^c P[~]c@[~]•á			Q cÄV[cä]
	Š^c	V@~	Ö[~]ÉV[cä]	Š^c	Üä @	Ö[~]ÉV[cä]	V@~	Üä @	Ö[~]ÉV[cä]	
É KÉÁÖE	í	J	FÍ	€	í	í	í	F	í	HÉ
É KÍ ÁÖE	í	FF	FÍ	F	í	í	í	F	í	HÉ
É KÉÁÖE	J	FÍ	G	í	J	FÍ	FF	G	FH	ÍH
É KÍ ÁÖE	í	J	FÍ	H	í	í	FF	€	FF	H
V[cä]	G	ÍÍ	ÍG	F€	G	H	H	I	H	FÍÍ
É KÉÁÖE	ì	FH	GF	I	ì	FG	FH	H	FÍ	IJ
É KÍ ÁÖE	ì	F€	FÍ	G	ì	FG	FF	G	FH	H
É KÉÁÖE	ì	FH	FÍ	í	ì	FÍ	F€	í	FÍ	ÍÍ
É KÍ ÁÖE	ì	FJ	G	í	ì	FH	F€	í	FÍ	ÍÍ
V[cä]	G	ÍÍ	ÍG	FÍ	H€	ÍÍ	ÍÍ	FÍ	ÍF	FJ€
Ö[~]•áÁV[cä]	íí	F€€	FÍÍ	G	íí	íí	íí	GF	JJ	HÍ
Ö[~]•:áÁV[cä]	HÍÉ	ÍÍÉ	Á	H€É	ííÉ	Á	ííÉ	GF€G	Á	Á
V[cä]	FÍ	GJÉ	ÍÍÉ	í	FÍÉ	GÉ	GÉ	ÍÉ	GJÉ	

ÚcäöÁ/ã ^	Öä ^ááÁÜd^^c U[~]c@[~]•á			ÚáááÁÖ[ä öP ä @ ä ÁÜä] Y ^•cá[~]•á			Öä ^ááÁÜd^^c P[~]c@[~]•á			Q cÄV[cä]
	Š^c	V@~	Ö[~]ÉV[cä]	Š^c	Üä @	Ö[~]ÉV[cä]	V@~	Üä @	Ö[~]ÉV[cä]	
É KÉÁÖE	9	16	25	6	9	15	FF	G	FH	53
É KÍ ÁÖE	í	J	FÍ	H	í	í	FF	€	FF	H
É KÉÁÖE	í	FH	GF	I	ì	FG	13	3	16	IJ
É KÍ ÁÖE	ì	F€	FÍ	G	ì	í	FF	G	FH	H
V[cä]	H€	ÍÍ	ÍÍ	FÍ	G	ÍH	ÍÍ	í	ÍH	FÍÍ
Á Ö[~]ÉV[cä]	HÍÉ	ÍFÉ	Á	HÉ	ííÉ	Á	ííÉ	FHG	Á	Á
UPØ	ÉH	ÉÍ€	ÉÍ€	ÉG	ÉÍ	ÉFÍ	ÉÍ	ÉÍH	ÉG	ÉGF

Ú^ä ÁP[~]•:áÁV[cä] { ÁÉ KÉÁÖE ÁÉ KÍ ÁÖE ÁÜä ÁÁ-Á
 Ú^ä ÁP[~]•:Á[~]•(Á) c^ÁQ c^•^&á } Á^*á • ÁÁÉ KÉÁÖE

Ó[~}•ÁM|ãããÁQ&É
 UUÁQ]cÁFíí
 Ó[!|]ããÁQ&Éíí
 Q|FÁQ|ÉÉí

Óã Á -Á[]*Á^ãã@
 ÞEUIKQãã ^ããÁUd^^c
 ÖEY KÁãããÁQ]ããÁ @ããÁUã]
 Y^ãã@!KÁ" } } ^

Q^ Áãã ^ KÖÓÓÖSÚÓPÜCÉ
 Úã ÁQ] á^ KÉÉÉÉÉÉ F
 ÚããÁQãã KÖBUBDEFG
 Úãã ÁQ] KÖ

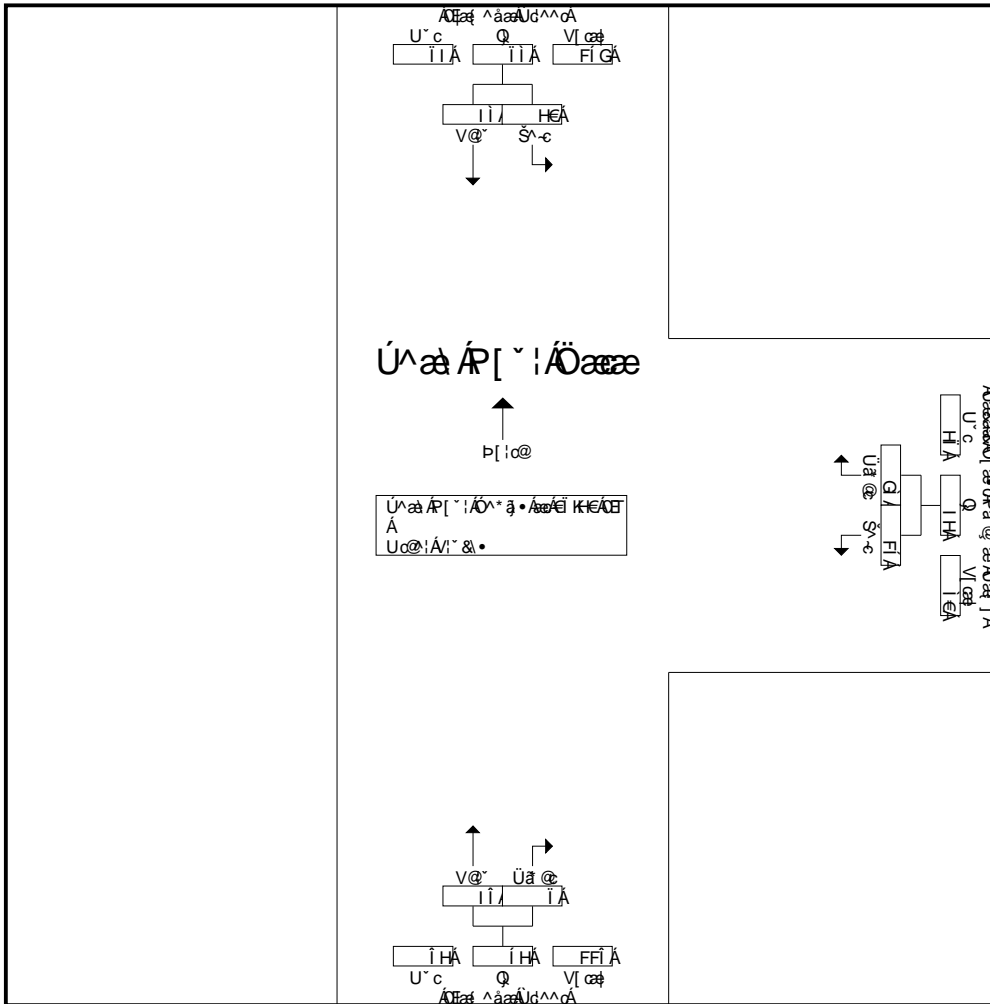

Úãã ÁR[~!ÁQãã•ãÁQ]! Áí KÍKÁQÉ Áí Áí KÍ ÁQÉ ÁÁÚãã ÁRÁ -Á
 Úãã ÁR[~!Á!ÁÖããQÉ]!|ããÁQ^ãã•ÁãK

	Éí KÍKÁQÉ			Éí KÍKÁQÉ			Éí KÍKÁQÉ		
ÉÉÁ á•É	9	16	25	6	9	15	FF	G	FH
ÉFÍÁ á•É	í	J	Fí	H	í	í	FF	€	FF
ÉHEÁ á•É	ì	FH	GF	I	ì	FG	13	3	16
ÉÍÁ á•É	ï	F€	Fí	G	í	ì	FF	G	FH
V cãK] { ^	HE	ÍÍ	ÍÍ	Fí	Q	IH	ÍÍ	í	ÍH
Á ÁQ] ÉV cã	H É	Í FÉ	Á	H É	Í Í É	Á	Í Í É	F H G	Á
UPØ	É H H	É Í €	É Í €	É G	É Í	É Fí	É Í	É Í H	É G

0[~) 0 ÁM |ã æ á Q&E
 UUÁOj cAFI I
 0[() æ 00ÁG I i
 QI FDG i È G I

Ôæ Á -S[] * Á^æ@
 PDUKÇæ ^áæÁD^c
 OBY KÁææáÁ[æ O P á @ æ ÁUæ]
 Y ^æ@:KÁ" } }

0P ^æ ^ K SÓOCSUÓPÜT Ö
 Úæ ÁO[á^ K CCCCC F
 Úæ Oææ K C B J B E F G
 Úæ ^ Á[K F

Groups Printed- Passenger vehicles - Bobtail Trucks - Chasis Only Trucks - Container Trucks - Other trucks

Start Time	Alameda Street Southbound			Pacific Coast Highway Ramp Westbound			Alameda Street Northbound			Int. Total
	Left	Thru	App. Total	Left	Right	App. Total	Thru	Right	App. Total	
01:00 PM	40	71	111	31	38	69	58	31	89	269
01:15 PM	30	100	130	22	39	61	89	35	124	315
01:30 PM	41	90	131	22	49	71	91	35	126	328
01:45 PM	51	94	145	27	50	77	78	27	105	327
Total	162	355	517	102	176	278	316	128	444	1239
02:00 PM	34	69	103	23	73	96	100	26	126	325
02:15 PM	41	93	134	31	54	85	90	23	113	332
02:30 PM	41	103	144	26	57	83	83	46	129	356
02:45 PM	60	102	162	22	58	80	85	53	138	380
Total	176	367	543	102	242	344	358	148	506	1393
Grand Total	338	722	1060	204	418	622	674	276	950	2632
Apprch %	31.9	68.1		32.8	67.2		70.9	29.1		
Total %	12.8	27.4	40.3	7.8	15.9	23.6	25.6	10.5	36.1	
Passenger vehicles	283	423	706	140	342	482	390	217	607	1795
% Passenger vehicles	83.7	58.6	66.6	68.6	81.8	77.5	57.9	78.6	63.9	68.2
Bobtail Trucks	17	87	104	21	24	45	94	28	122	271
% Bobtail Trucks	5	12	9.8	10.3	5.7	7.2	13.9	10.1	12.8	10.3
Chasis Only Trucks	2	7	9	7	9	16	19	3	22	47
% Chasis Only Trucks	0.6	1	0.8	3.4	2.2	2.6	2.8	1.1	2.3	1.8
Container Trucks	21	136	157	21	12	33	81	10	91	281
% Container Trucks	6.2	18.8	14.8	10.3	2.9	5.3	12	3.6	9.6	10.7
Other trucks	15	69	84	15	31	46	90	18	108	238
% Other trucks	4.4	9.6	7.9	7.4	7.4	7.4	13.4	6.5	11.4	9

Start Time	Alameda Street Southbound			Pacific Coast Highway Ramp Westbound			Alameda Street Northbound			Int. Total
	Left	Thru	App. Total	Left	Right	App. Total	Thru	Right	App. Total	
02:00 PM	34	69	103	23	73	96	100	26	126	325
02:15 PM	41	93	134	31	54	85	90	23	113	332
02:30 PM	41	103	144	26	57	83	83	46	129	356
02:45 PM	60	102	162	22	58	80	85	53	138	380
Total Volume	176	367	543	102	242	344	358	148	506	1393
% App. Total	32.4	67.6		29.7	70.3		70.8	29.2		
PHF	.733	.891	.838	.823	.829	.896	.895	.698	.917	.916

Peak Hour Analysis From 02:00 PM to 02:45 PM - Peak 1 of 1

Peak Hour for Entire Intersection Begins at 02:00 PM

0[~ } 0 AM |ã äããQ&E
 UUÄJ cÄFFII
 Ö[!|] äãÖÖÄG I i
 QI FÄG i E G i

Öã Ä -Ä[] * Ä^ äã@
 ÞHJ KÖHä ^ããÄd^^c
 ÖEY KÄãããÄÖ[äã Öã @ äã ÄÜä]
 Y ^ äã@:KÄ" } } ^

ÖH^ Ä äã ^ KÖÖÖÖÜÖPÜT Ö
 Üã ÄÖ[ä^ KÖÖÖÖÖ F
 Üãã ÖÄä KÖBJBDEFG
 Üãã ^Ä[KÖ

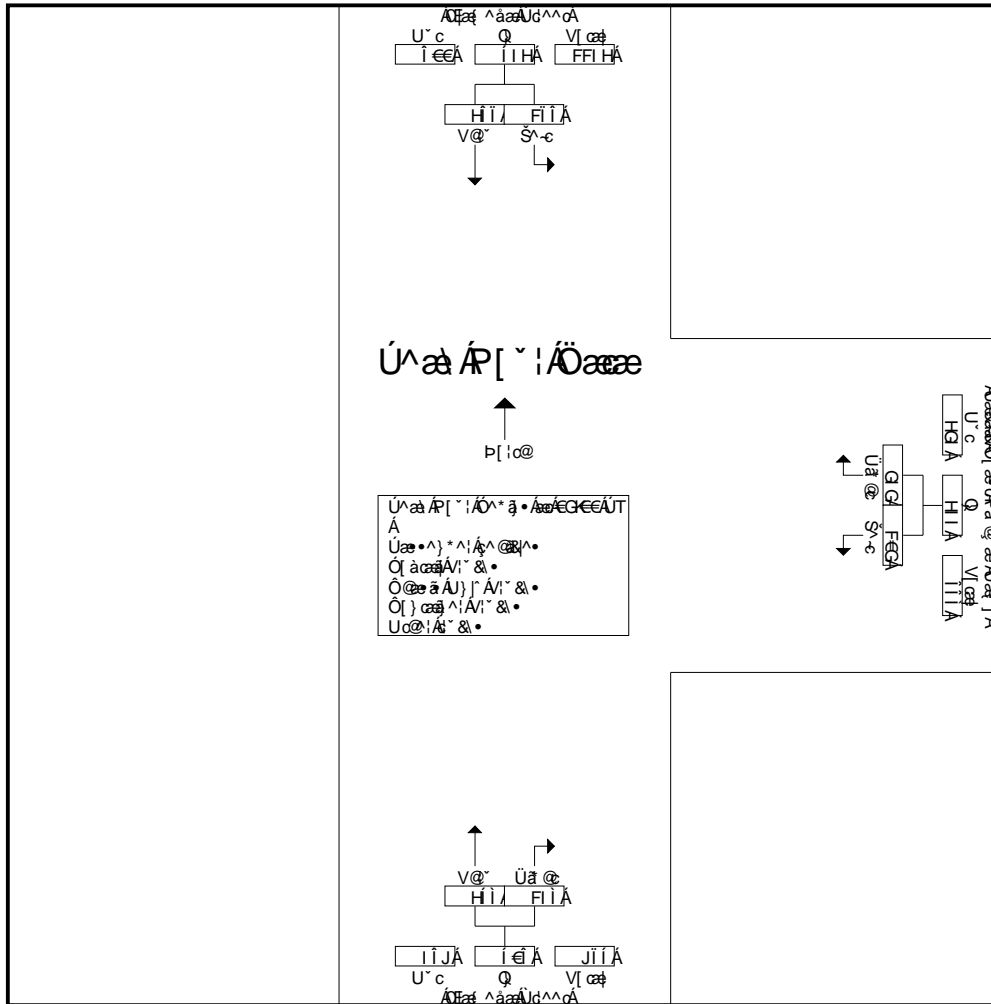

Üã ä ÄP[~ | ÄÖäææ * ä ÄÖ[{ ÄGÖÖÄÜT Ä ÄGK I ÄÜT ÄÜ^ ä ÄÄ Ä

Peak Hour for Each Approach Begins at:

	02:00 PM			02:00 PM			02:00 PM		
+0 mins.	34	69	103	23	73	96	100	26	126
+15 mins.	41	93	134	31	54	85	90	23	113
+30 mins.	41	103	144	26	57	83	83	46	129
+45 mins.	60	102	162	22	58	80	85	53	138
Total Volume	176	367	543	102	242	344	358	148	506
% App. Total	32.4	67.6		29.7	70.3		70.8	29.2	
PHF	.733	.891	.838	.823	.829	.896	.895	.698	.917

01:00 AM
 01:15 AM
 01:30 AM
 01:45 AM

01:00 PM
 01:15 PM
 01:30 PM
 01:45 PM
 Total

02:00 PM
 02:15 PM
 02:30 PM
 02:45 PM
 Total

Groups Printed- Passenger vehicles

Start Time	Alameda Street Southbound			Pacific Coast Highway Ramp Westbound			Alameda Street Northbound			Int. Total
	Left	Thru	App. Total	Left	Right	App. Total	Thru	Right	App. Total	
01:00 PM	36	45	81	24	32	56	34	25	59	196
01:15 PM	26	59	85	18	26	44	47	26	73	202
01:30 PM	36	60	96	15	44	59	57	29	86	241
01:45 PM	43	53	96	20	41	61	48	24	72	229
Total	141	217	358	77	143	220	186	104	290	868
02:00 PM	25	43	68	15	59	74	52	22	74	216
02:15 PM	34	52	86	15	45	60	43	15	58	204
02:30 PM	36	46	82	16	44	60	56	34	90	232
02:45 PM	47	65	112	17	51	68	53	42	95	275
Total	142	206	348	63	199	262	204	113	317	927
Grand Total	283	423	706	140	342	482	390	217	607	1795
Apprch %	40.1	59.9		29	71		64.3	35.7		
Total %	15.8	23.6	39.3	7.8	19.1	26.9	21.7	12.1	33.8	

Start Time	Alameda Street Southbound			Pacific Coast Highway Ramp Westbound			Alameda Street Northbound			Int. Total
	Left	Thru	App. Total	Left	Right	App. Total	Thru	Right	App. Total	
02:00 PM	25	43	68	15	59	74	52	22	74	216
02:15 PM	34	52	86	15	45	60	43	15	58	204
02:30 PM	36	46	82	16	44	60	56	34	90	232
02:45 PM	47	65	112	17	51	68	53	42	95	275
Total Volume	142	206	348	63	199	262	204	113	317	927
% App. Total	40.8	59.2		24	76		64.4	35.6		
PHF	.755	.792	.777	.926	.843	.885	.911	.673	.834	.843

Peak Hour Analysis From 02:00 PM to 02:45 PM - Peak 1 of 1
 Peak Hour for Entire Intersection Begins at 02:00 PM

0[~ } o AM | a a a Q & E
 U U A O | c A F F I I
 O [! |] a a O O A U G I I
 Q I F D G I E G I

O a t A - A [] * A O ^ a a @
 P B U I K O C H a a a U d ^ ^ c
 O E Y K U a a a a A O [a e o P a @ a s A U a]
 Y ^ a a @ : K A U } } ^

O P ^ A a a ^ K S O O C S U O P U T O
 U a a A O [a ^ K E E E E E F
 U a a o O a a K C B U B E F G
 U a a ^ A P [K G

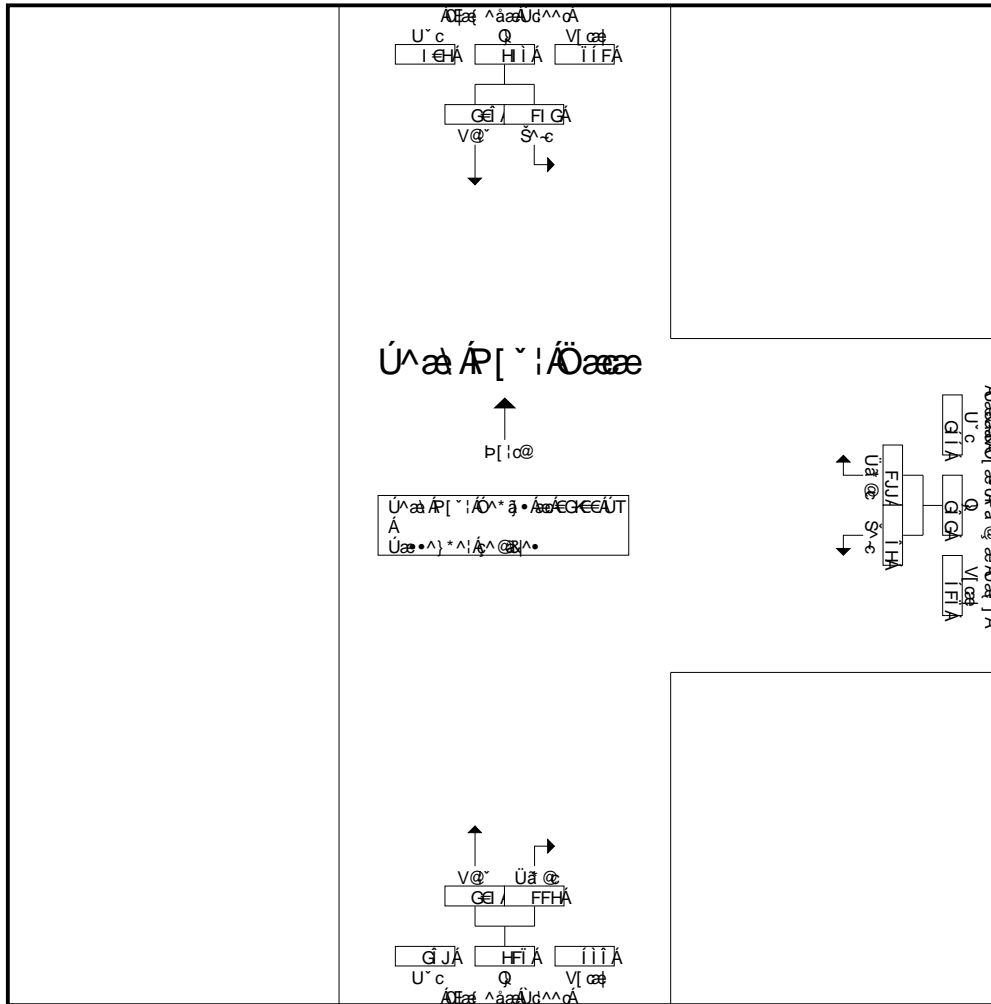

U^ a a A P [~ | A O a a e } a A O [{ A E G E A U T A t A E G K i A U T A A U ^ a a A A - A
 Peak Hour for Each Approach Begins at:

	02:00 PM			02:00 PM			02:00 PM		
+0 mins.	25	43	68	15	59	74	52	22	74
+15 mins.	34	52	86	15	45	60	43	15	58
+30 mins.	36	46	82	16	44	60	56	34	90
+45 mins.	47	65	112	17	51	68	53	42	95
Total Volume	142	206	348	63	199	262	204	113	317
% App. Total	40.8	59.2		24	76		64.4	35.6	
PHF	.755	.792	.777	.926	.843	.885	.911	.673	.834

0[~) 0 AM |ã æ á Á Q&E
 UUÁŒ cAFI I
 ÖI () æÖÖÁG I i
 QI FDG i È G i

Öæ Á -S[] * ÁŒ æ@
 PDUKŒæ ^ááÁŒd^^c
 ÖEY KÁæááÁŒ[æ ö P á @ æ ÁŒæ]
 Y ^æ@:KÁ } } ^

Öæ Á æ ^ KÖÖÖÖÖÖÖÖÖ Ö
 Úæ ÁŒ[á ^ KÖÖÖÖÖ F
 Úæ ö Öæ ^ KÖÖÖÖ ÖFG
 Úæ ^ ÁŒ[KÖ

Groups Printed- Bobtail Trucks

Start Time	Alameda Street Southbound			Pacific Coast Highway Ramp Westbound			Alameda Street Northbound			Int. Total
	Left	Thru	App. Total	Left	Right	App. Total	Thru	Right	App. Total	
01:00 PM	2	9	11	1	1	2	7	3	10	23
01:15 PM	1	12	13	1	7	8	17	3	20	41
01:30 PM	1	5	6	2	1	3	10	2	12	21
01:45 PM	4	9	13	2	2	4	7	3	10	27
Total	8	35	43	6	11	17	41	11	52	112
02:00 PM	3	11	14	2	5	7	20	3	23	44
02:15 PM	1	12	13	6	4	10	11	5	16	39
02:30 PM	1	19	20	3	4	7	11	5	16	43
02:45 PM	4	10	14	4	0	4	11	4	15	33
Total	9	52	61	15	13	28	53	17	70	159
Grand Total	17	87	104	21	24	45	94	28	122	271
Apprch %	16.3	83.7		46.7	53.3		77	23		
Total %	6.3	32.1	38.4	7.7	8.9	16.6	34.7	10.3	45	

Start Time	Alameda Street Southbound			Pacific Coast Highway Ramp Westbound			Alameda Street Northbound			Int. Total
	Left	Thru	App. Total	Left	Right	App. Total	Thru	Right	App. Total	
02:00 PM	3	11	14	2	5	7	20	3	23	44
02:15 PM	1	12	13	6	4	10	11	5	16	39
02:30 PM	1	19	20	3	4	7	11	5	16	43
02:45 PM	4	10	14	4	0	4	11	4	15	33
Total Volume	9	52	61	15	13	28	53	17	70	159
% App. Total	14.8	85.2		53.6	46.4		75.7	24.3		
PHF	.563	.684	.763	.625	.650	.700	.663	.850	.761	.903

Peak Hour Analysis From 02:00 PM to 02:45 PM - Peak 1 of 1
 Peak Hour for Entire Intersection Begins at 02:00 PM

0[~ } 0 AM | a a a Q & E
 UU A Q c A F I I
 0[! |] a a 0 0 A G I I
 Q I F D G I E G I

0 a t A - A [] * A ^ a a @
 P H U K C H a a a U d ^ a c
 O E Y K U a a a A [a e o r a @ a e A U a]
 Y ^ a a @ ! K U } } ^

0 a t A a a ^ K S O O C S U O P U T O
 U a a A O [a a K E E E E E F
 U a a o O a a K C B J B E F G
 U a a ^ A [K G

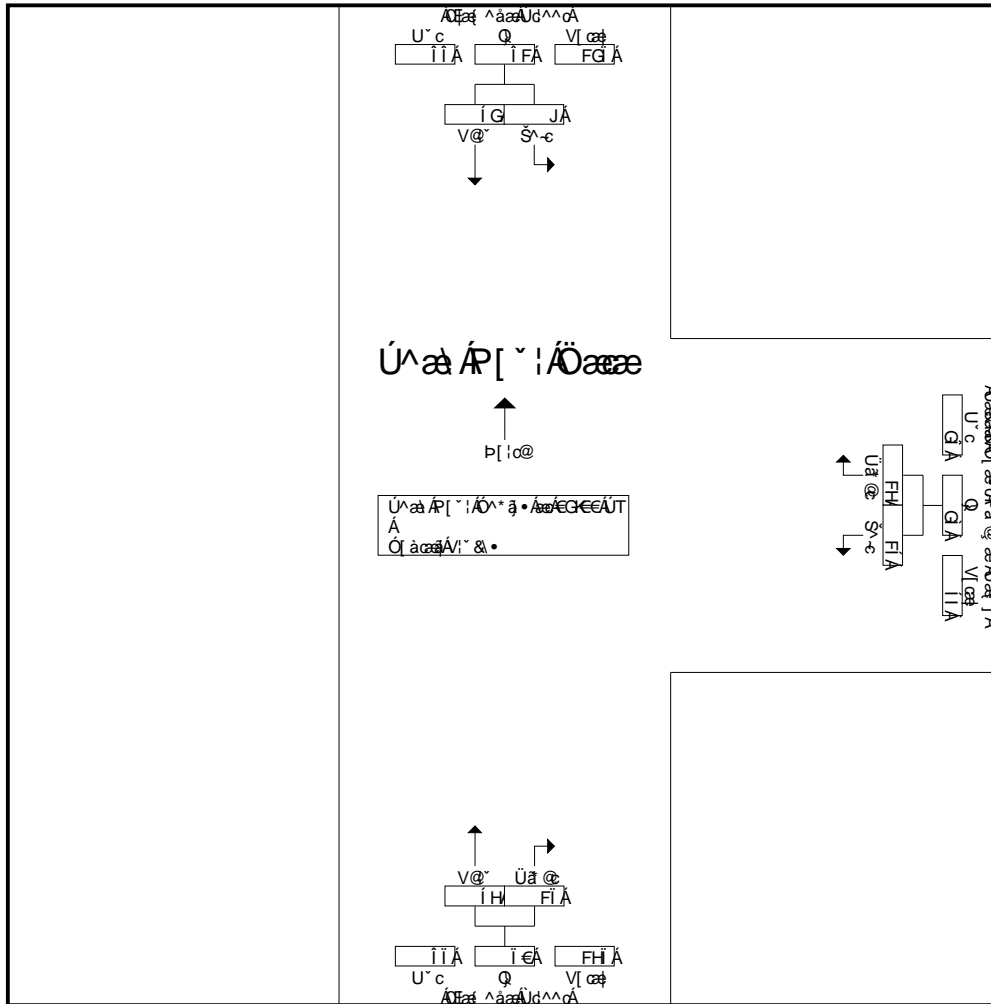

U a a A P [~ ! A O a a e • a A O [{ A E G E A U T A E G K I A U T A U a a A A A - A
 Peak Hour for Each Approach Begins at:

	02:00 PM			02:00 PM			02:00 PM		
+0 mins.	3	11	14	2	5	7	20	3	23
+15 mins.	1	12	13	6	4	10	11	5	16
+30 mins.	1	19	20	3	4	7	11	5	16
+45 mins.	4	10	14	4	0	4	11	4	15
Total Volume	9	52	61	15	13	28	53	17	70
% App. Total	14.8	85.2		53.6	46.4		75.7	24.3	
PHF	.563	.684	.763	.625	.650	.700	.663	.850	.761

0[~) 0 AM |ã æ á Á Q&E
 UUÁO cAFI I
 Ô I () æ 00Á G I i
 QI FD G i E G I

Ôæ Á -S[] * Á ^æ @
 PDUK Oæ ^áæ Á D ^c
 OBY K Áæáá Á [æ o P á @ æ Á Üæ]
 Y ^æ @ : K U } }

Qæ Á Pæ ^ K S O O C S U O P U T Ö
 Üæ Á O [á ^ K C C C C C F
 Üæ o Oæ ^ K C B J B D E F G
 Üæ ^ Á [K F

Groups Printed- Chasis Only Trucks

Start Time	Alameda Street Southbound			Pacific Coast Highway Ramp Westbound			Alameda Street Northbound			Int. Total
	Left	Thru	App. Total	Left	Right	App. Total	Thru	Right	App. Total	
01:00 PM	0	0	0	3	0	3	0	0	0	3
01:15 PM	0	0	0	0	0	0	5	0	5	5
01:30 PM	0	0	0	0	0	0	2	0	2	2
01:45 PM	0	0	0	0	1	1	1	0	1	2
Total	0	0	0	3	1	4	8	0	8	12
02:00 PM	0	2	2	0	4	4	3	0	3	9
02:15 PM	0	2	2	3	2	5	4	1	5	12
02:30 PM	0	3	3	1	0	1	1	1	2	6
02:45 PM	2	0	2	0	2	2	3	1	4	8
Total	2	7	9	4	8	12	11	3	14	35
Grand Total	2	7	9	7	9	16	19	3	22	47
Apprch %	22.2	77.8		43.8	56.2		86.4	13.6		
Total %	4.3	14.9	19.1	14.9	19.1	34	40.4	6.4	46.8	

Start Time	Alameda Street Southbound			Pacific Coast Highway Ramp Westbound			Alameda Street Northbound			Int. Total
	Left	Thru	App. Total	Left	Right	App. Total	Thru	Right	App. Total	
02:00 PM	0	2	2	0	4	4	3	0	3	9
02:15 PM	0	2	2	3	2	5	4	1	5	12
02:30 PM	0	3	3	1	0	1	1	1	2	6
02:45 PM	2	0	2	0	2	2	3	1	4	8
Total Volume	2	7	9	4	8	12	11	3	14	35
% App. Total	22.2	77.8		33.3	66.7		78.6	21.4		
PHF	.250	.583	.750	.333	.500	.600	.688	.750	.700	.729

Peak Hour Analysis From 02:00 PM to 02:45 PM - Peak 1 of 1
 Peak Hour for Entire Intersection Begins at 02:00 PM

0[~ } . 0 AM | a . a a Q & E
 U U A Q | c A F F I I
 0 [: [] } a a 0 0 A G I i
 Q I F D G i E d i

0 a t A - A [] * A ^ a s @
 P B U I K O H a a a U d ^ A ^ c
 O E Y K U a s a a A [a e o r a @ a s A U a]
 Y ^ a a @ : K A } } ^

0 a t A a s ^ K S O O C S U O P U T O
 U a t A O [a ^ K E E E E E F
 U a s o A a e K C B U B E F G
 U a s ^ A [K G

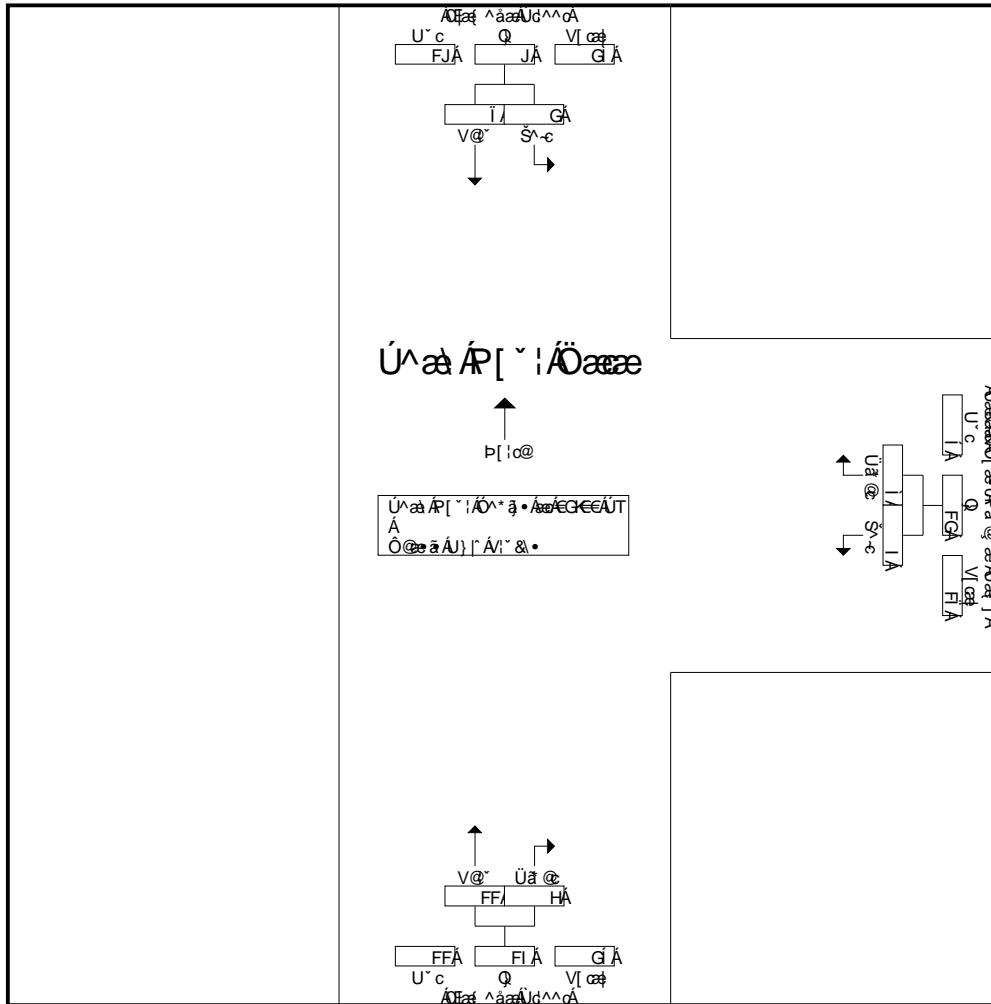

U a s A R [~ | A O a e e • a A O [{ A E G E E A U T A t A E G K i A U T A U ^ a s A A - A
 Peak Hour for Each Approach Begins at:

	02:00 PM			02:00 PM			02:00 PM		
+0 mins.	0	2	2	0	4	4	3	0	3
+15 mins.	0	2	2	3	2	5	4	1	5
+30 mins.	0	3	3	1	0	1	1	1	2
+45 mins.	2	0	2	0	2	2	3	1	4
Total Volume	2	7	9	4	8	12	11	3	14
% App. Total	22.2	77.8		33.3	66.7		78.6	21.4	
PHF	.250	.583	.750	.333	.500	.600	.688	.750	.700

0[~) . 0 ÁM |ã ä á ÁQ&É
 UUÁÖ cÁFI I
 ÖI () äÖÖÁG I i
 QI FDG i È G i

Öä Á -Á[] * ÁÖ^æ@
 PDUKÖFä ^ääÁÜd^^c
 ÖEY KÁasääÁÖ[ä ö P ä @ ä ÁÜæ]
 Y ^æ@:KÜ" } } ^

ÖP^ Á æ ^ KÖÖÖÖÖÜÖPÜT Ö
 Üä ÁÖ[ä^ KÖÖÖÖÖ F
 Üæ ö Öæ^ KÖBÜBDFG
 Üæ ^ Á [KÖ

Groups Printed- Container Trucks

Start Time	Alameda Street Southbound			Pacific Coast Highway Ramp Westbound			Alameda Street Northbound			Int. Total
	Left	Thru	App. Total	Left	Right	App. Total	Thru	Right	App. Total	
01:00 PM	1	13	14	2	1	3	7	0	7	24
01:15 PM	3	17	20	2	3	5	5	2	7	32
01:30 PM	1	16	17	3	1	4	7	2	9	30
01:45 PM	2	23	25	4	1	5	12	0	12	42
Total	7	69	76	11	6	17	31	4	35	128
02:00 PM	2	7	9	6	1	7	12	0	12	28
02:15 PM	2	15	17	2	0	2	19	1	20	39
02:30 PM	4	25	29	2	3	5	11	3	14	48
02:45 PM	6	20	26	0	2	2	8	2	10	38
Total	14	67	81	10	6	16	50	6	56	153
Grand Total	21	136	157	21	12	33	81	10	91	281
Apprch %	13.4	86.6		63.6	36.4		89	11		
Total %	7.5	48.4	55.9	7.5	4.3	11.7	28.8	3.6	32.4	

Start Time	Alameda Street Southbound			Pacific Coast Highway Ramp Westbound			Alameda Street Northbound			Int. Total
	Left	Thru	App. Total	Left	Right	App. Total	Thru	Right	App. Total	
02:00 PM	2	7	9	6	1	7	12	0	12	28
02:15 PM	2	15	17	2	0	2	19	1	20	39
02:30 PM	4	25	29	2	3	5	11	3	14	48
02:45 PM	6	20	26	0	2	2	8	2	10	38
Total Volume	14	67	81	10	6	16	50	6	56	153
% App. Total	17.3	82.7		62.5	37.5		89.3	10.7		
PHF	.583	.670	.698	.417	.500	.571	.658	.500	.700	.797

Peak Hour Analysis From 02:00 PM to 02:45 PM - Peak 1 of 1
 Peak Hour for Entire Intersection Begins at 02:00 PM

0[~ } 0 AM |ã äããQ&E
 UUÄJ cAFii
 Ö[!|] äããÖÄGii
 QI FÄGii Eäi

Öã Ä -Ä[] * Ä^ãã@
 ÞEJÄÖãä äããÄd^c
 ÖEY ÄÜãããÄ[äããÄ @ äãÄã]
 Y ^ãã@:ÄÜ" } } ^

ÖÄ Ä äã ^ ÄÖÖÖÜÖPÜT Ö
 Üã ÄÖ[ä^ ÄÖÖÖÖ F
 ÜããÖãä ÄÖBÜBDFG
 Üãä ^Ä[ÄG

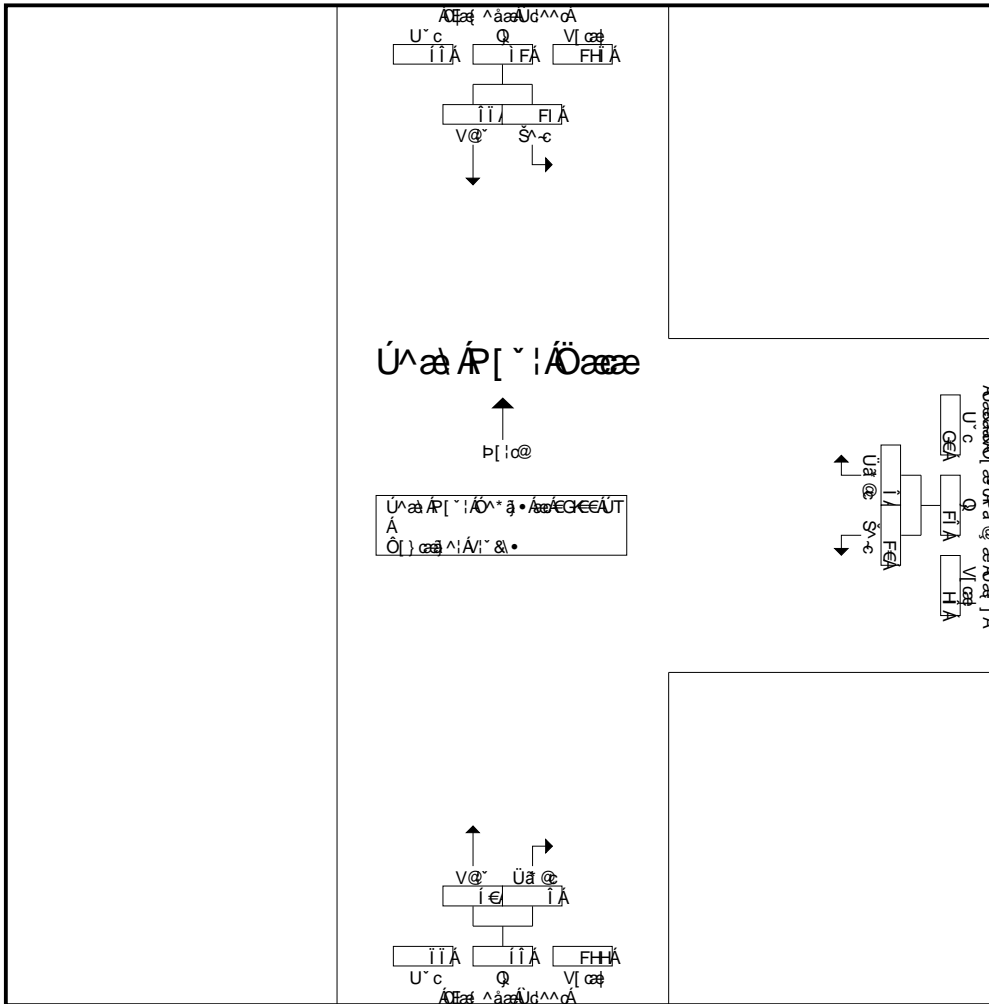

Üãä ÄP[~ | ÄÖãäë • äããÄ[{ ÄGEEÄÜT ÄÄ ÄGK i ÄÜT ÄÄÜãä ÄÄÄ ÄÄ

Peak Hour for Each Approach Begins at:

	02:00 PM			02:00 PM			02:00 PM		
+0 mins.	2	7	9	6	1	7	12	0	12
+15 mins.	2	15	17	2	0	2	19	1	20
+30 mins.	4	25	29	2	3	5	11	3	14
+45 mins.	6	20	26	0	2	2	8	2	10
Total Volume	14	67	81	10	6	16	50	6	56
% App. Total	17.3	82.7		62.5	37.5		89.3	10.7	
PHF	.583	.670	.698	.417	.500	.571	.658	.500	.700

0[~) 0 AM |ã æ á Á Q&E
 UUÁŒ cAFI I
 0[() æ 00Á G I i
 QI FD G i E G I

0ã Á -S[] * Á ^æ @
 PDUKŒæ ^ããÁŒd^^c
 0EY KÁãããÁŒ æ 0Pã @ æ ÁŒæ]
 Y ^æ @ :KÁ } } ^

0E^ Á æ ^ K S O O C S U O P U T Ö
 Úã ÁŒ á ^ K C C C C C F
 Úã 0 Á æ K C B J B E F G
 Úã ^ Á [K F

Groups Printed- Other trucks

Start Time	Alameda Street Southbound			Pacific Coast Highway Ramp Westbound			Alameda Street Northbound			Int. Total
	Left	Thru	App. Total	Left	Right	App. Total	Thru	Right	App. Total	
01:00 PM	1	4	5	1	4	5	10	3	13	23
01:15 PM	0	12	12	1	3	4	15	4	19	35
01:30 PM	3	9	12	2	3	5	15	2	17	34
01:45 PM	2	9	11	1	5	6	10	0	10	27
Total	6	34	40	5	15	20	50	9	59	119
02:00 PM	4	6	10	0	4	4	13	1	14	28
02:15 PM	4	12	16	5	3	8	13	1	14	38
02:30 PM	0	10	10	4	6	10	4	3	7	27
02:45 PM	1	7	8	1	3	4	10	4	14	26
Total	9	35	44	10	16	26	40	9	49	119
Grand Total	15	69	84	15	31	46	90	18	108	238
Apprch %	17.9	82.1		32.6	67.4		83.3	16.7		
Total %	6.3	29	35.3	6.3	13	19.3	37.8	7.6	45.4	

Start Time	Alameda Street Southbound			Pacific Coast Highway Ramp Westbound			Alameda Street Northbound			Int. Total
	Left	Thru	App. Total	Left	Right	App. Total	Thru	Right	App. Total	
02:00 PM	4	6	10	0	4	4	13	1	14	28
02:15 PM	4	12	16	5	3	8	13	1	14	38
02:30 PM	0	10	10	4	6	10	4	3	7	27
02:45 PM	1	7	8	1	3	4	10	4	14	26
Total Volume	9	35	44	10	16	26	40	9	49	119
% App. Total	20.5	79.5		38.5	61.5		81.6	18.4		
PHF	.563	.729	.688	.500	.667	.650	.769	.563	.875	.783

Peak Hour Analysis From 02:00 PM to 02:45 PM - Peak 1 of 1
 Peak Hour for Entire Intersection Begins at 02:00 PM

Ö[~ } , o AM | ä ä a Q & E
 UUÄÖ | c A F I I
 Ö[! |] ä ä Ö A G I i
 Q I F D G i E d i

Öä Ä -Ä[] * A^ ä ä @
 P H U K O Ä ä ä ä U d ^ ^ c
 Ö E Y K U ä ä ä A [ä ä ö Ä @ ä ä U ä ä]
 Y ^ ä ä @ ! Ä U " } } ^

Ö Ä Ä ä ä ^ K S Ö Ö C S U Ö P Ü T Ö
 Ü ä ä A Ö [ä ä ^ K E E E E E E F
 Ü ä ä ö A ä ä ^ K C B U B E F G
 Ü ä ä ^ Ä [K G

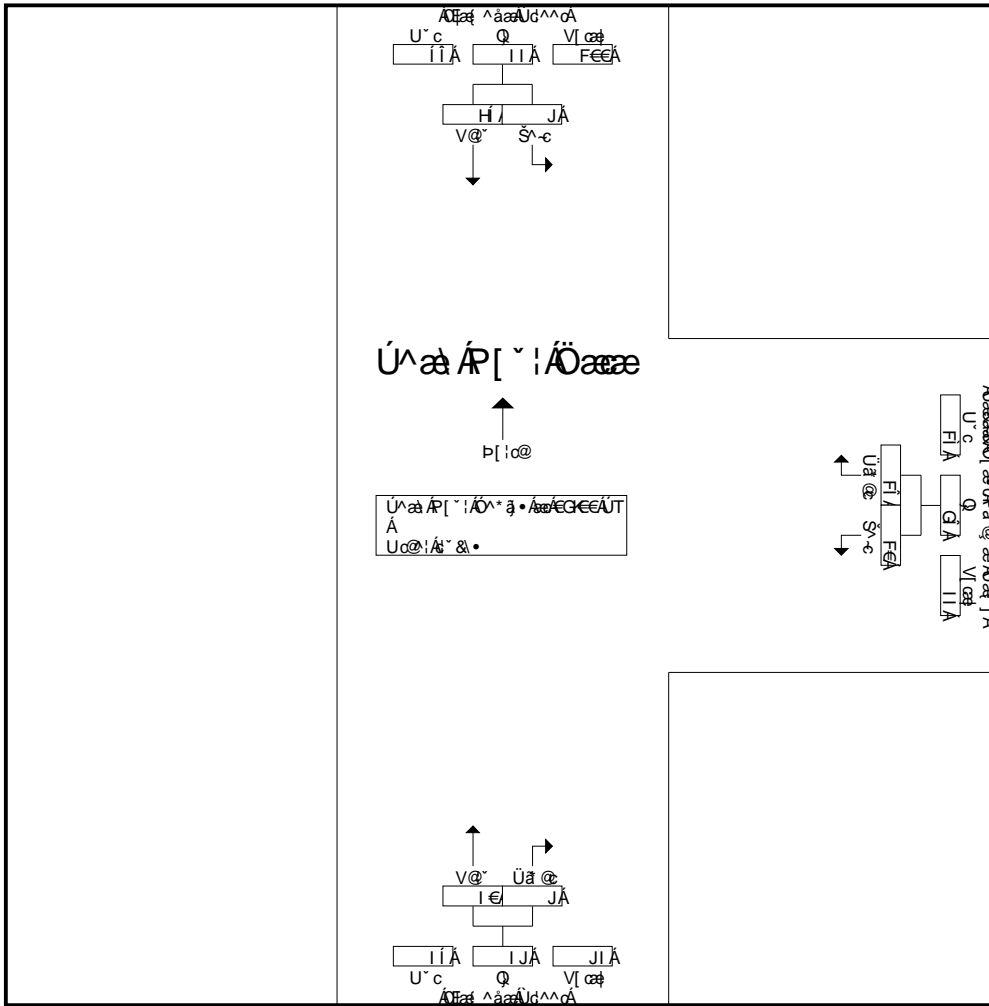

Ü ä ä Ä P [~ ! A Ö ä ä ä • ä ä A [{ Ä G E E Ä Ü T Ä Ä G K i Ä Ü T Ä U ä ä Ä Ä Ä - Ä
 Peak Hour for Each Approach Begins at:

	02:00 PM			02:00 PM			02:00 PM		
+0 mins.	4	6	10	0	4	4	13	1	14
+15 mins.	4	12	16	5	3	8	13	1	14
+30 mins.	0	10	10	4	6	10	4	3	7
+45 mins.	1	7	8	1	3	4	10	4	14
Total Volume	9	35	44	10	16	26	40	9	49
% App. Total	20.5	79.5		38.5	61.5		81.6	18.4	
PHF	.563	.729	.688	.500	.667	.650	.769	.563	.875

0[~) 0 ÁM |ã æ á Q&E
 UUÁOj cAFI I
 0[() æ 00ÁG I i
 QI FDG i È G I

0ã Á -S[] * ÁO^æ@
 PDUKÇæ ^ããÁUd^c
 OBY KÁJããÁO[æ oPã @ æ ÁUæ]
 Y ^æ@:KÁ" } } ^

0ã Á æ ^ K5000SÚOPÚT
 Úã ÁO[á^ KCCCCC F
 Úæ oOææ KGBJ BDFG
 Úæ ^ Á[KÆ

Groups Printed- Passenger Vehicles - Bobtail Trucks - Chasis Only Trucks - Container Trucks - Other Trucks

Start Time	Alameda Street Southbound			Pacific Coast Highway Ramp Westbound			Alameda Street Northbound			Int. Total
	Left	Thru	App. Total	Left	Right	App. Total	Thru	Right	App. Total	
04:00 PM	60	169	229	19	62	81	117	33	150	460
04:15 PM	73	158	231	25	70	95	147	48	195	521
04:30 PM	71	161	232	26	101	127	161	43	204	563
04:45 PM	78	160	238	22	74	96	129	25	154	488
Total	282	648	930	92	307	399	554	149	703	2032
05:00 PM	69	146	215	25	162	187	121	34	155	557
05:15 PM	70	142	212	26	80	106	108	25	133	451
05:30 PM	71	118	189	15	97	112	103	27	130	431
05:45 PM	60	75	135	15	63	78	105	21	126	339
Total	270	481	751	81	402	483	437	107	544	1778
Grand Total	552	1129	1681	173	709	882	991	256	1247	3810
Apprch %	32.8	67.2		19.6	80.4		79.5	20.5		
Total %	14.5	29.6	44.1	4.5	18.6	23.1	26	6.7	32.7	
Passenger Vehicles	471	741	1212	122	676	798	725	205	930	2940
% Passenger Vehicles	85.3	65.6	72.1	70.5	95.3	90.5	73.2	80.1	74.6	77.2
Bobtail Trucks	33	109	142	34	9	43	116	25	141	326
% Bobtail Trucks	6	9.7	8.4	19.7	1.3	4.9	11.7	9.8	11.3	8.6
Chasis Only Trucks	9	21	30	0	3	3	15	2	17	50
% Chasis Only Trucks	1.6	1.9	1.8	0	0.4	0.3	1.5	0.8	1.4	1.3
Container Trucks	22	181	203	11	8	19	55	17	72	294
% Container Trucks	4	16	12.1	6.4	1.1	2.2	5.5	6.6	5.8	7.7
Other Trucks	17	77	94	6	13	19	80	7	87	200
% Other Trucks	3.1	6.8	5.6	3.5	1.8	2.2	8.1	2.7	7	5.2

Start Time	Alameda Street Southbound			Pacific Coast Highway Ramp Westbound			Alameda Street Northbound			Int. Total
	Left	Thru	App. Total	Left	Right	App. Total	Thru	Right	App. Total	
04:15 PM	73	158	231	25	70	95	147	48	195	521
04:30 PM	71	161	232	26	101	127	161	43	204	563
04:45 PM	78	160	238	22	74	96	129	25	154	488
05:00 PM	69	146	215	25	162	187	121	34	155	557
Total Volume	291	625	916	98	407	505	558	150	708	2129
% App. Total	31.8	68.2		19.4	80.6		78.8	21.2		
PHF	.933	.970	.962	.942	.628	.675	.866	.781	.868	.945

Peak Hour Analysis From 04:00 PM to 05:45 PM - Peak 1 of 1

Peak Hour for Entire Intersection Begins at 04:15 PM

Ö[~ } • ÄM | ä ä ä Ä & E
 U U Ä Ö c Ä F I I
 Ö [!] } ä ä Ö Ä G I i
 Q I F D G i E G i

Ö ä Ä - Ä [] * Ä ^ ä ä @
 P B U K C H ä ä ä Ä d ^ ^ c
 Ö E Y Ä U ä ä ä Ä [ä ö Ä ä @ ä ä Ä ä]
 Y ^ ä ä @ ! Ä U } } ^

Ö ä Ä ä ^ Ä Ö Ö Ö S U Ö P U T
 U ä Ä Ö [ä ^ Ä Ö Ö Ö Ö F
 U ä ä ö Ä ä Ä Ä G B J B D E F G
 U ä ä Ä [Ä G

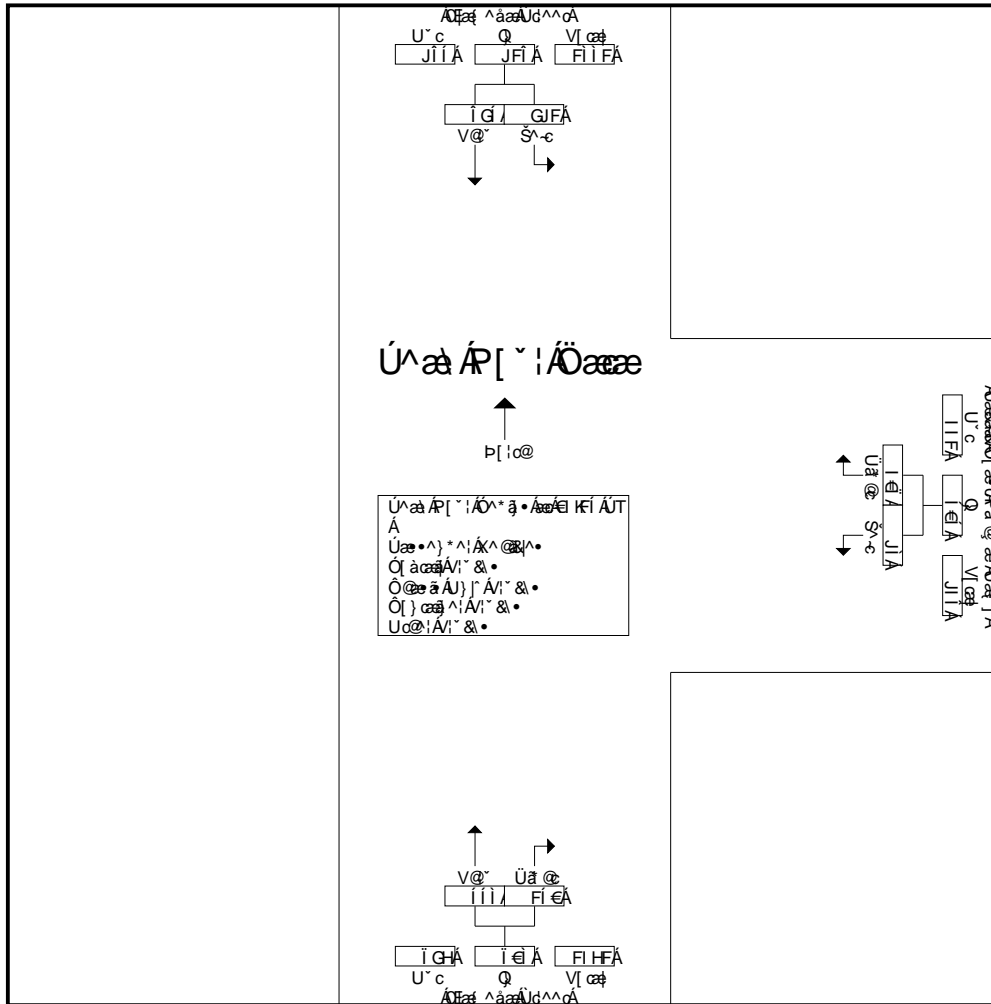

U^ ä ä Ä P [~ ! Ä Ö ä ä ä { Ä I Ä Ö Ä T Ä Ä I Ä I Ä U T Ä U^ ä ä Ä Ä Ä Ä

Peak Hour for Each Approach Begins at:

	04:00 PM			04:30 PM			04:15 PM		
+0 mins.	60	169	229	26	101	127	147	48	195
+15 mins.	73	158	231	22	74	96	161	43	204
+30 mins.	71	161	232	25	162	187	129	25	154
+45 mins.	78	160	238	26	80	106	121	34	155
Total Volume	282	648	930	99	417	516	558	150	708
% App. Total	30.3	69.7		19.2	80.8		78.8	21.2	
PHF	.904	.959	.977	.952	.644	.690	.866	.781	.868

0[~) 0 ÁM |ã ä á Q&E
 UUÁO cAFI I
 Ô[() äÖÖÁG I i
 QI FDG i È G I

Ôã Á -S[] * Á^ã@
 PDUKÇã ^ããÁD^c
 ÖY KÁãããÁ[ä ö Pã @ ä Áã]
 Y ^ã@:KÁ" } } ^

Ôã Áã ^ KÖÖÖSÜÖPÜT
 Üã ÁO[ä^ KÉÉÉÉÉ F
 Üã ö Öãã KÖBUBDFG
 Üã ^ Á[K

Groups Printed- Passenger Vehicles

Start Time	Alameda Street Southbound			Pacific Coast Highway Ramp Westbound			Alameda Street Northbound			Int. Total
	Left	Thru	App. Total	Left	Right	App. Total	Thru	Right	App. Total	
04:00 PM	52	109	161	13	57	70	73	23	96	327
04:15 PM	61	108	169	17	63	80	113	41	154	403
04:30 PM	58	125	183	21	96	117	115	32	147	447
04:45 PM	67	107	174	18	70	88	91	19	110	372
Total	238	449	687	69	286	355	392	115	507	1549
05:00 PM	60	101	161	19	158	177	97	30	127	465
05:15 PM	61	91	152	14	76	90	93	21	114	356
05:30 PM	59	58	117	9	93	102	73	24	97	316
05:45 PM	53	42	95	11	63	74	70	15	85	254
Total	233	292	525	53	390	443	333	90	423	1391
Grand Total	471	741	1212	122	676	798	725	205	930	2940
Apprch %	38.9	61.1		15.3	84.7		78	22		
Total %	16	25.2	41.2	4.1	23	27.1	24.7	7	31.6	

Start Time	Alameda Street Southbound			Pacific Coast Highway Ramp Westbound			Alameda Street Northbound			Int. Total
	Left	Thru	App. Total	Left	Right	App. Total	Thru	Right	App. Total	
04:15 PM	61	108	169	17	63	80	113	41	154	403
04:30 PM	58	125	183	21	96	117	115	32	147	447
04:45 PM	67	107	174	18	70	88	91	19	110	372
05:00 PM	60	101	161	19	158	177	97	30	127	465
Total Volume	246	441	687	75	387	462	416	122	538	1687
% App. Total	35.8	64.2		16.2	83.8		77.3	22.7		
PHF	.918	.882	.939	.893	.612	.653	.904	.744	.873	.907

Peak Hour Analysis From 04:15 PM to 05:30 PM - Peak 1 of 1
 Peak Hour for Entire Intersection Begins at 04:15 PM

0[~ } 0 AM |ã äããQ&E
 UUÄQ cÄFI I
 Ö[!|] äãÖÖÄG I i
 QI FÄG I E G I

Öã Ä -Ä[] *Ä^ãã@
 ÞHUKÖHä ^ããÄd^c
 ÖEY KÄãããÄ[ä öPã @ äÄÜä]
 Y ^ãã@:KÄ" } } ^

Öã Ä ä ^ KÖÖÖÜÖPÜÜT
 Üã ÄÖ[ä ^ KÖÖÖÖÖ F
 Üã öÖäã KÖÖJHDEFG
 Üã Ä Ä[KÖ

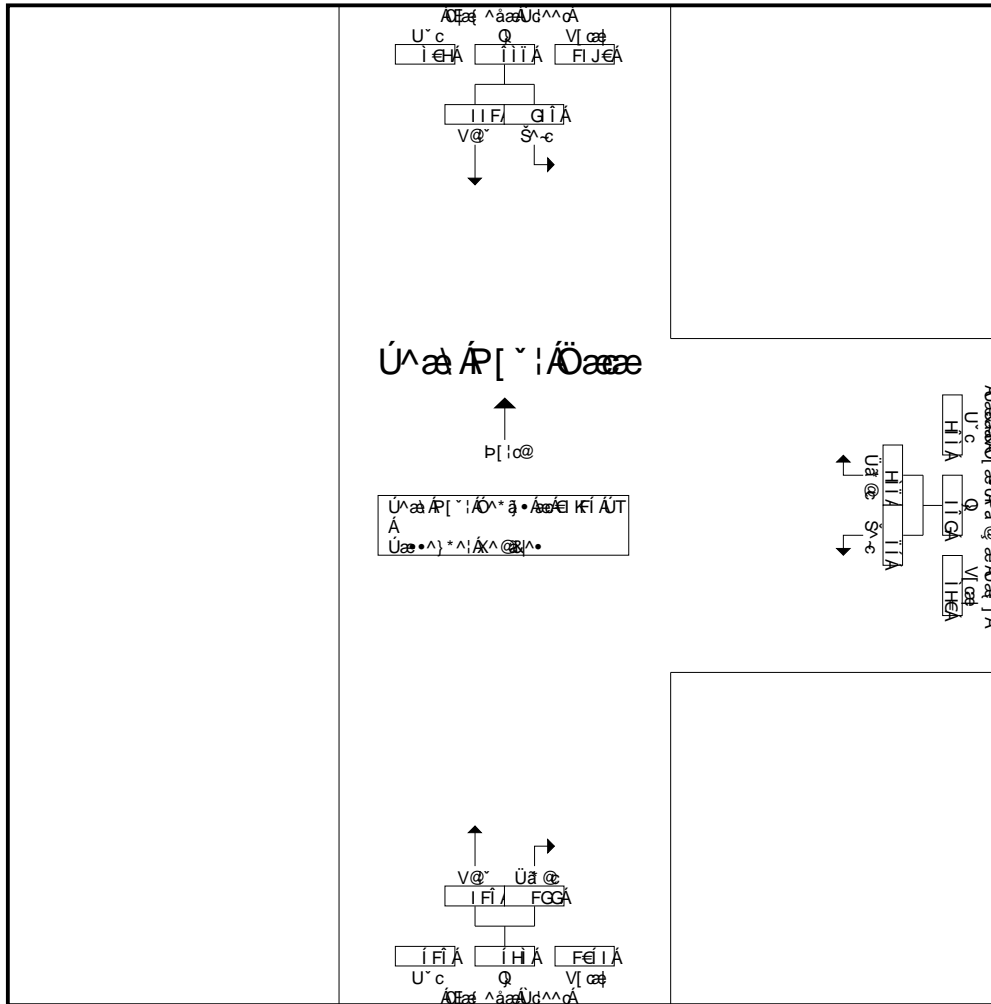

Üã ä ÄP[~ |ÄÖäææ • äÄ[{ Ä I KÄÜT Ä Ä I KÄÜT ÄÜã ä ÄÄ Ä

Peak Hour for Each Approach Begins at:

	04:15 PM			04:30 PM			04:45 PM		
+0 mins.	61	108	169	21	96	117	113	41	154
+15 mins.	58	125	183	18	70	88	115	32	147
+30 mins.	67	107	174	19	158	177	91	19	110
+45 mins.	60	101	161	14	76	90	97	30	127
Total Volume	246	441	687	72	400	472	416	122	538
% App. Total	35.8	64.2		15.3	84.7		77.3	22.7	
PHF	.918	.882	.939	.857	.633	.667	.904	.744	.873

0[~) 0 ÁM |ã ä á ÁQ&É
 UUÁOj cÁFI I
 Ô[!|) äÖÖÁG I i
 QI FDG i È G I

Ôã Á -S|) * Á^ã@
 PDUKÇã ^ããÁÜd^^c
 ÖEY KÁãããÁ[ä ö Pã @ ä ÁÜã]
 Y ^ã@:KÜ } } ^

Ôã Áã ^ KÖÖÖÖÖÜÖPÜÜT
 Üã ÁÖ| ä^ KÉÉÉÉÉ F
 Üã ö Öãã KÖÖJ BDEFG
 Üã ^ Á[KÉ

Groups Printed- Bobtail Trucks

Start Time	Alameda Street Southbound			Pacific Coast Highway Ramp Westbound			Alameda Street Northbound			Int. Total
	Left	Thru	App. Total	Left	Right	App. Total	Thru	Right	App. Total	
04:00 PM	1	7	8	4	1	5	15	5	20	33
04:15 PM	3	16	19	7	2	9	15	5	20	48
04:30 PM	3	10	13	4	3	7	32	3	35	55
04:45 PM	5	23	28	2	0	2	14	4	18	48
Total	12	56	68	17	6	23	76	17	93	184
05:00 PM	6	15	21	3	2	5	11	1	12	38
05:15 PM	7	17	24	9	1	10	3	0	3	37
05:30 PM	6	15	21	2	0	2	11	3	14	37
05:45 PM	2	6	8	3	0	3	15	4	19	30
Total	21	53	74	17	3	20	40	8	48	142
Grand Total	33	109	142	34	9	43	116	25	141	326
Apprch %	23.2	76.8		79.1	20.9		82.3	17.7		
Total %	10.1	33.4	43.6	10.4	2.8	13.2	35.6	7.7	43.3	

Start Time	Alameda Street Southbound			Pacific Coast Highway Ramp Westbound			Alameda Street Northbound			Int. Total
	Left	Thru	App. Total	Left	Right	App. Total	Thru	Right	App. Total	
04:15 PM	3	16	19	7	2	9	15	5	20	48
04:30 PM	3	10	13	4	3	7	32	3	35	55
04:45 PM	5	23	28	2	0	2	14	4	18	48
05:00 PM	6	15	21	3	2	5	11	1	12	38
Total Volume	17	64	81	16	7	23	72	13	85	189
% App. Total	21	79		69.6	30.4		84.7	15.3		
PHF	.708	.696	.723	.571	.583	.639	.563	.650	.607	.859

Peak Hour Analysis From 04:15 PM to 05:30 PM - Peak 1 of 1
 Peak Hour for Entire Intersection Begins at 04:15 PM

0[~ } . 0 AM | a . a a Q & E
 UU A Q c A F I I
 0 [! |] a a 0 0 A G I i
 Q I F D G i E d i

0 a t A - A [] * A ^ a s @
 P B U I K O C a a ^ a a U d ^ a c
 O E Y K U a s a a A [a e o r a @ a s U a s]
 Y ^ a a @ : K U } } ^

0 a ^ A a s ^ K S O O O S U O P U T
 U a a A O [a ^ K E E E E E F
 U c a s o A a a K G B J B D E F G
 U a s ^ A p [K G

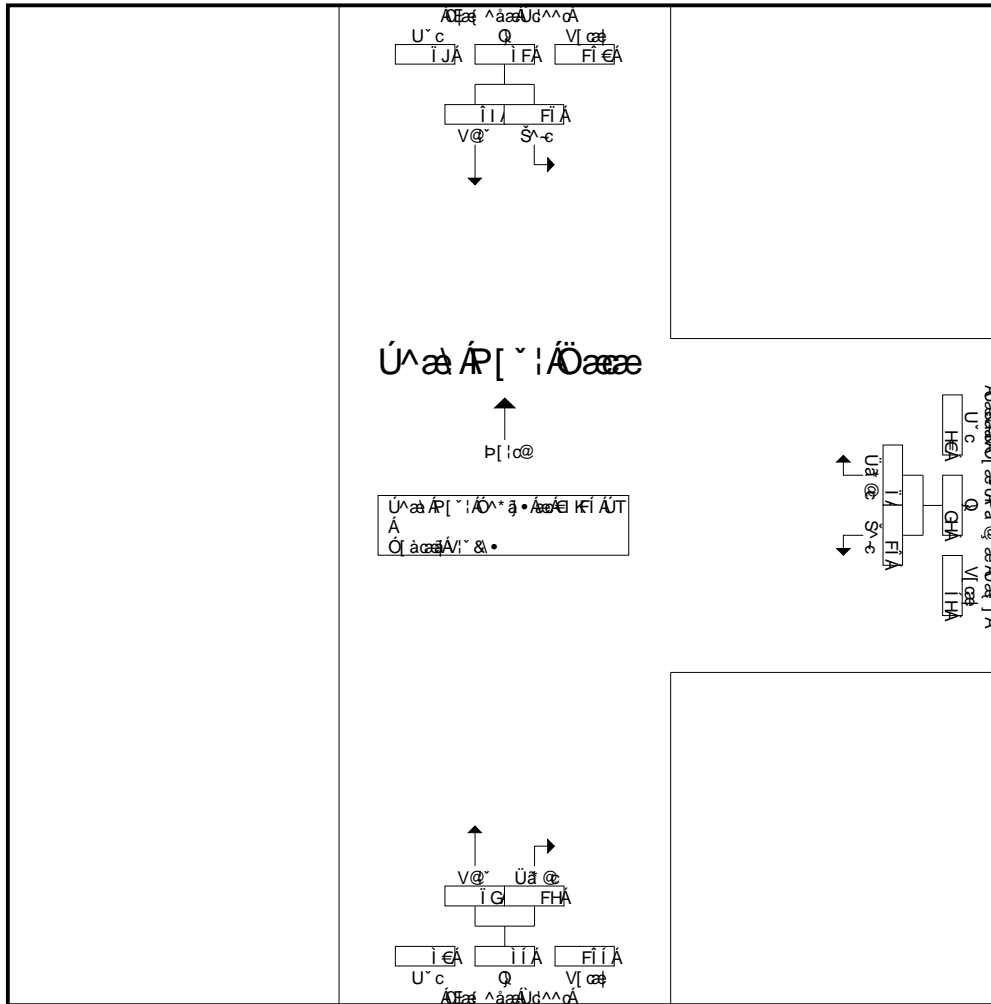

U^ a a A P [~ | A O a a e . a A O [{ A e I K I A U T A e A e I K E A U T A U ^ a a A e A - A
 Peak Hour for Each Approach Begins at:

	04:45 PM			04:30 PM			04:15 PM		
+0 mins.	5	23	28	4	3	7	15	5	20
+15 mins.	6	15	21	2	0	2	32	3	35
+30 mins.	7	17	24	3	2	5	14	4	18
+45 mins.	6	15	21	9	1	10	11	1	12
Total Volume	24	70	94	18	6	24	72	13	85
% App. Total	25.5	74.5		75	25		84.7	15.3	
PHF	.857	.761	.839	.500	.500	.600	.563	.650	.607

0[~) 0 ÁM |ã ä á ÁQ&É
 UUÁÖ cÁFI I
 ÖI () äÖÖÁG I i
 QI FDG i È G I

Öä Á -S[] * Á^ ä@
 PDUKÖEä ^ääÁÜd^^c
 ÖEY KÁääáÁÖ[ä öP ä @ ä ÁÜä]
 Y ^ ä@ :KÜ } } ^

Öä Á ä ^ KÖÖÖÖÖÜÖPÜÜT
 Üä ÁÖ[ä ^ KÖÖÖÖÖ F
 Üä ö Öää KÖÖÖÖÖ F
 Üä ^ Á [KÖ

Groups Printed- Chasis Only Trucks

Start Time	Alameda Street Southbound			Pacific Coast Highway Ramp Westbound			Alameda Street Northbound			Int. Total
	Left	Thru	App. Total	Left	Right	App. Total	Thru	Right	App. Total	
04:00 PM	0	6	6	0	1	1	3	0	3	10
04:15 PM	1	2	3	0	1	1	0	1	1	5
04:30 PM	6	4	10	0	0	0	2	0	2	12
04:45 PM	0	0	0	0	1	1	0	1	1	2
Total	7	12	19	0	3	3	5	2	7	29
05:00 PM	0	2	2	0	0	0	0	0	0	2
05:15 PM	0	0	0	0	0	0	1	0	1	1
05:30 PM	2	6	8	0	0	0	6	0	6	14
05:45 PM	0	1	1	0	0	0	3	0	3	4
Total	2	9	11	0	0	0	10	0	10	21
Grand Total	9	21	30	0	3	3	15	2	17	50
Apprch %	30	70		0	100		88.2	11.8		
Total %	18	42	60	0	6	6	30	4	34	

Start Time	Alameda Street Southbound			Pacific Coast Highway Ramp Westbound			Alameda Street Northbound			Int. Total
	Left	Thru	App. Total	Left	Right	App. Total	Thru	Right	App. Total	
04:15 PM	1	2	3	0	1	1	0	1	1	5
04:30 PM	6	4	10	0	0	0	2	0	2	12
04:45 PM	0	0	0	0	1	1	0	1	1	2
05:00 PM	0	2	2	0	0	0	0	0	0	2
Total Volume	7	8	15	0	2	2	2	2	4	21
% App. Total	46.7	53.3		0	100		50	50		
PHF	.292	.500	.375	.000	.500	.500	.250	.500	.500	.438

Peak Hour Analysis From 04:15 PM to 05:30 PM - Peak 1 of 1
 Peak Hour for Entire Intersection Begins at 04:15 PM

0[^ } . 0 AM | a a a Q & E
 U U A O | c A F F I I
 0 [! |] a a 0 0 A G I i
 Q I F D G i E d i

0 a t A - A [] * A ^ a a @
 P B U I K O C H a a a A d ^ ^ c
 O E Y K U a a a a A [a e o r a @ a s A U a]
 Y ^ a a @ ! K U } } ^

0 a ^ A a a ^ K S O O O S U O P U T
 U a a A O | a ^ K E E E E E F
 U c a a o A a a K G B J B D E F G
 U a a ^ A [K G

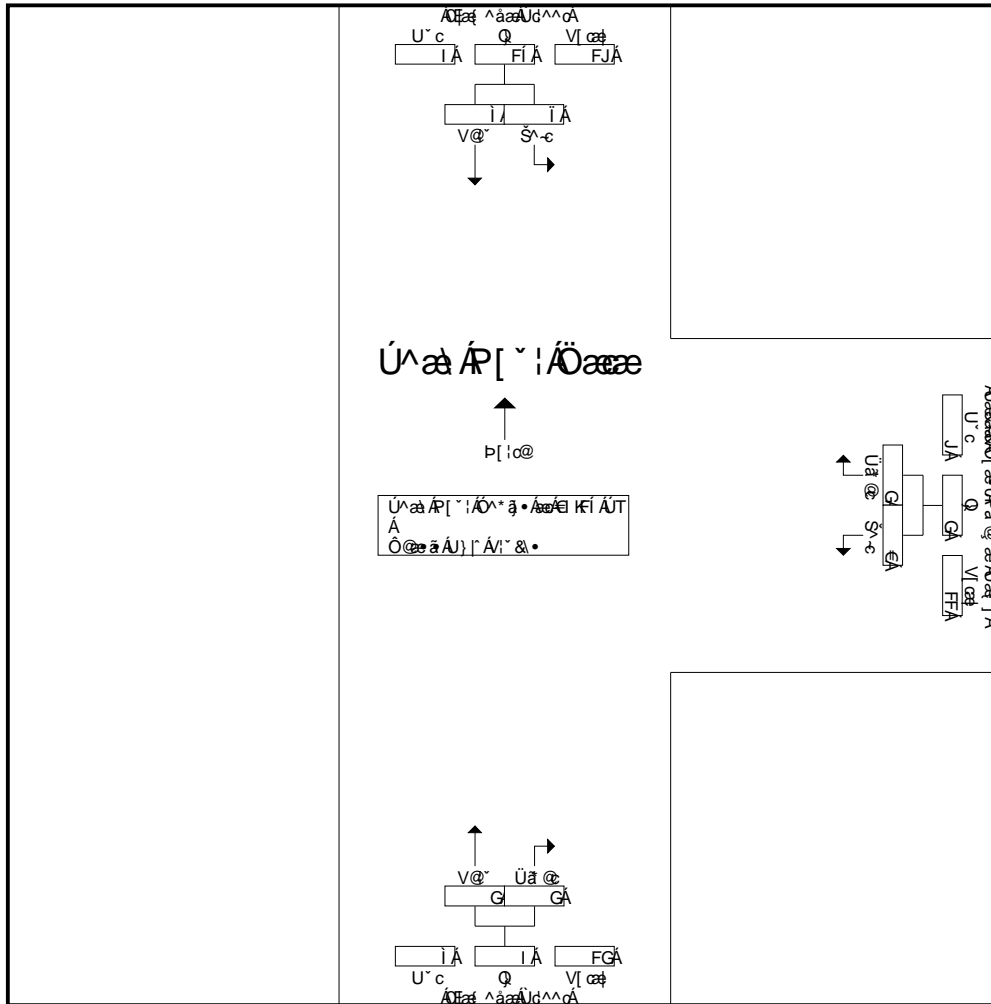

U^ a a A P [^ | A O a a e * a A O [{ A e I K F I A U T A e A e I K E A U T A U ^ a a A A A A A
 Peak Hour for Each Approach Begins at:

	04:15 PM			04:15 PM			04:45 PM		
+0 mins.	1	2	3	0	1	1	0	1	1
+15 mins.	6	4	10	0	0	0	0	0	0
+30 mins.	0	0	0	0	1	1	1	0	1
+45 mins.	0	2	2	0	0	0	6	0	6
Total Volume	7	8	15	0	2	2	7	1	8
% App. Total	46.7	53.3		0	100		87.5	12.5	
PHF	.292	.500	.375	.000	.500	.500	.292	.250	.333

0[~) 0 ÁM |ã æ á ÁQ&E
 UUÁOj cAFI I
 Ô[() æ 00ÁG I i
 QI FDG i È G I

Ôæ Á -S[] * ÁOæ@
 PDUKÇæ ^ããÁD^c
 OBY KÚããÁO[æ óPã @ æ ÁÚæ]
 Y ^æ@:KÚ } } ^

Qã ÁPæ ^ K500SÚOPÚT
 Úã ÁO[á^ KCCCCCF
 ÚæóOææ KGBJDEFG
 Úæ ^ ÁP[K&

Groups Printed- Container Trucks

Start Time	Alameda Street Southbound			Pacific Coast Highway Ramp Westbound			Alameda Street Northbound			Int. Total
	Left	Thru	App. Total	Left	Right	App. Total	Thru	Right	App. Total	
04:00 PM	4	37	41	1	1	2	11	4	15	58
04:15 PM	4	20	24	0	2	2	12	0	12	38
04:30 PM	4	18	22	1	0	1	6	6	12	35
04:45 PM	1	23	24	2	1	3	7	0	7	34
Total	13	98	111	4	4	8	36	10	46	165
05:00 PM	1	21	22	3	0	3	5	2	7	32
05:15 PM	2	23	25	1	1	2	2	3	5	32
05:30 PM	3	22	25	3	3	6	4	0	4	35
05:45 PM	3	17	20	0	0	0	8	2	10	30
Total	9	83	92	7	4	11	19	7	26	129
Grand Total	22	181	203	11	8	19	55	17	72	294
Apprch %	10.8	89.2		57.9	42.1		76.4	23.6		
Total %	7.5	61.6	69	3.7	2.7	6.5	18.7	5.8	24.5	

Start Time	Alameda Street Southbound			Pacific Coast Highway Ramp Westbound			Alameda Street Northbound			Int. Total
	Left	Thru	App. Total	Left	Right	App. Total	Thru	Right	App. Total	
04:15 PM	4	20	24	0	2	2	12	0	12	38
04:30 PM	4	18	22	1	0	1	6	6	12	35
04:45 PM	1	23	24	2	1	3	7	0	7	34
05:00 PM	1	21	22	3	0	3	5	2	7	32
Total Volume	10	82	92	6	3	9	30	8	38	139
% App. Total	10.9	89.1		66.7	33.3		78.9	21.1		
PHF	.625	.891	.958	.500	.375	.750	.625	.333	.792	.914

Peak Hour Analysis From 04:15 PM to 05:30 PM - Peak 1 of 1

Peak Hour for Entire Intersection Begins at 04:15 PM

0[^) . o AM | a a a Q & E
 U U A O | c A F F I I
 O [! |] a a O O A G I i
 Q I F D G i E d i

O a t A - S [] * A O ^ a s @
 P B U I K O C a a ^ a a A U d ^ A ^ c
 O E Y K U a s a a A O [a e o P a @ a s A U a]
 Y ^ a a @ : K A U } } ^

O a ^ P a s ^ K S O O O S U O P U T
 U a a A O | a ^ K E C E C E C E F
 U c a s o O a a ^ K G B J B D E F G
 U a s ^ A P | K G

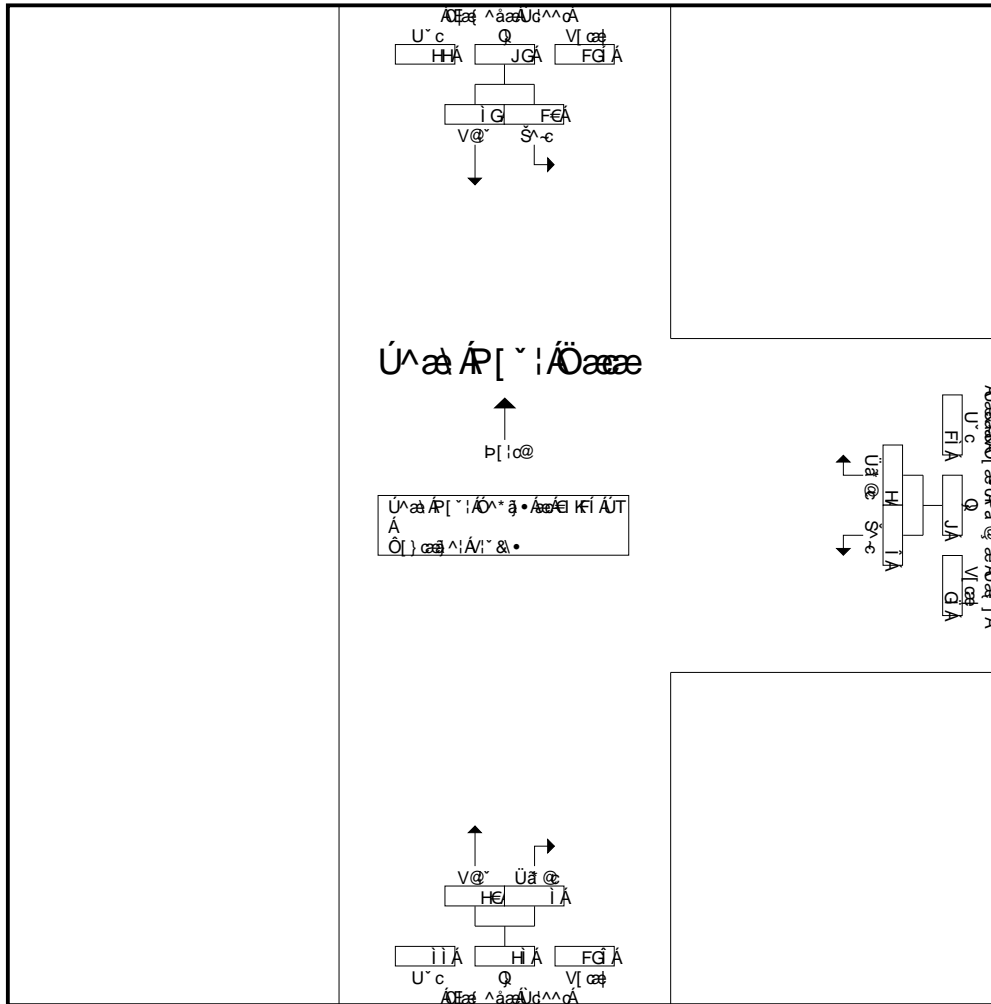

U a a A P [~ | A O a a e . a A O [{ A e I K I A U T A e A e I K E A U T A U ^ a a A e A ^ A - A
 Peak Hour for Each Approach Begins at:

	04:45 PM			04:45 PM			04:15 PM		
+0 mins.	1	23	24	2	1	3	12	0	12
+15 mins.	1	21	22	3	0	3	6	6	12
+30 mins.	2	23	25	1	1	2	7	0	7
+45 mins.	3	22	25	3	3	6	5	2	7
Total Volume	7	89	96	9	5	14	30	8	38
% App. Total	7.3	92.7		64.3	35.7		78.9	21.1	
PHF	.583	.967	.960	.750	.417	.583	.625	.333	.792

0[~) 0 ÁM |ã ä á ÁQ&É
 ÚUÁÚ cÁFI I
 0[() äÉÚÚG I i
 QI FDG i É G I

Óä Á -S[] * Á^ ä@
 PDUKÓEä ^ääÁÚd^^c
 ÖEY KÚääáÁÚ[ä öP ä @ ä ÁÚä]
 Y ^ ä@ :KÚ } } ^

Qä Á ä ^ KÖÖÖSÚÖPÚÜT
 Úä ÁÚ[ä ^ KÉÉÉÉÉ F
 Úä ö Ö ää KÖBÚBÉFG
 Úä ^ ÁÚ[KÉ

Groups Printed- Other Trucks

Start Time	Alameda Street Southbound			Pacific Coast Highway Ramp Westbound			Alameda Street Northbound			Int. Total
	Left	Thru	App. Total	Left	Right	App. Total	Thru	Right	App. Total	
04:00 PM	3	10	13	1	2	3	15	1	16	32
04:15 PM	4	12	16	1	2	3	7	1	8	27
04:30 PM	0	4	4	0	2	2	6	2	8	14
04:45 PM	5	7	12	0	2	2	17	1	18	32
Total	12	33	45	2	8	10	45	5	50	105
05:00 PM	2	7	9	0	2	2	8	1	9	20
05:15 PM	0	11	11	2	2	4	9	1	10	25
05:30 PM	1	17	18	1	1	2	9	0	9	29
05:45 PM	2	9	11	1	0	1	9	0	9	21
Total	5	44	49	4	5	9	35	2	37	95
Grand Total	17	77	94	6	13	19	80	7	87	200
Apprch %	18.1	81.9		31.6	68.4		92	8		
Total %	8.5	38.5	47	3	6.5	9.5	40	3.5	43.5	

Start Time	Alameda Street Southbound			Pacific Coast Highway Ramp Westbound			Alameda Street Northbound			Int. Total
	Left	Thru	App. Total	Left	Right	App. Total	Thru	Right	App. Total	
04:45 PM	5	7	12	0	2	2	17	1	18	32
05:00 PM	2	7	9	0	2	2	8	1	9	20
05:15 PM	0	11	11	2	2	4	9	1	10	25
05:30 PM	1	17	18	1	1	2	9	0	9	29
Total Volume	8	42	50	3	7	10	43	3	46	106
% App. Total	16	84		30	70		93.5	6.5		
PHF	.400	.618	.694	.375	.875	.625	.632	.750	.639	.828

Peak Hour Analysis From 04:15 PM to 05:30 PM - Peak 1 of 1
 Peak Hour for Entire Intersection Begins at 04:45 PM

0[^ } o AM |ã äããQ&E
 UUÄJ cÄFFI
 Ö[!|] äãÖÄG I i
 QI FÄG I E G I

Öã Ä -Ä[] * Ä^ äã@
 ÞEYKÖEä äãÄUd^c
 ÖEY KÄäããÄ[ä öPã @ äÄÜä]
 Y ^ äã@:KÄ" } } ^

Öã Ä ä ^ KÖÖÖÜÖPÜÜT
 Üã ÄÖ[ä ^ KÄÄÄÄÄÄ F
 Üäã öÄäã KÄBÄBÄEFG
 Üäã ÄP[KÄG

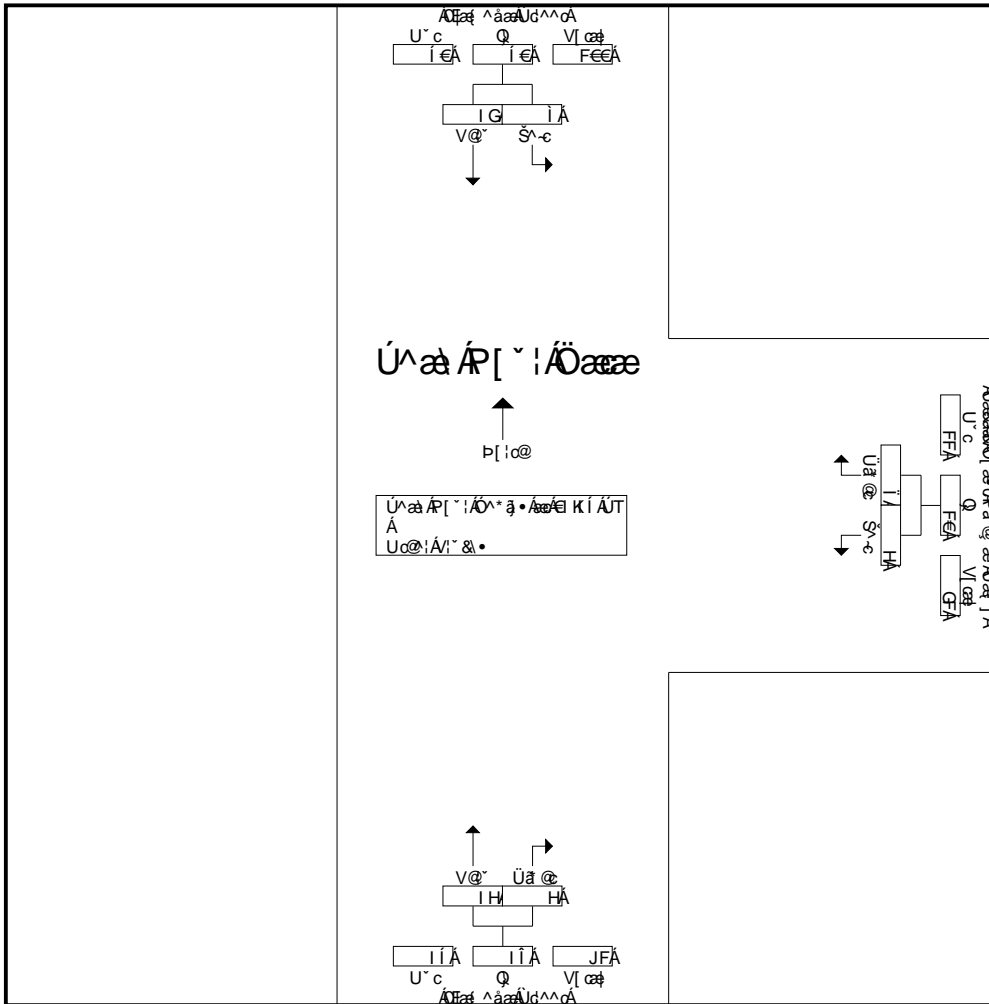

Ü^ä ÄP[^ | ÄÖäææ • äÄÄ[{ ÄI KÄÄÜT ÄÄ ÄI KÄÄÜT ÄÄÜ^ä ÄÄÄ -Ä
 Peak Hour for Each Approach Begins at:

	04:45 PM			04:30 PM			04:45 PM		
+0 mins.	5	7	12	0	2	2	17	1	18
+15 mins.	2	7	9	0	2	2	8	1	9
+30 mins.	0	11	11	0	2	2	9	1	10
+45 mins.	1	17	18	2	2	4	9	0	9
Total Volume	8	42	50	2	8	10	43	3	46
% App. Total	16	84		20	80		93.5	6.5	
PHF	.400	.618	.694	.250	1.000	.625	.632	.750	.639

Ô[~}•ÁM|ã ããÁQ&E
 UUÁOí cÁFI
 Ô[~}ãÁOáGí
 QI FdG í È G í

Ôã Á -Á[~}•ÁOã&@
 PBUKÁ~}•ÁQ íãÁOÁ~}•
 OBY KÁO~}•ÁUd^c
 Y^ã&@:KÁ~}•}

ÔÁ~}•Áã ^ K&OÓP.ÔOÓE
 Uã~}•ÁOí ãã K&E&E&E&E
 Uãã~}•ÁOã K&E&E&E&E
 Uãã~}•ÁOí K&E

Ô[~}•ÁUíãããÁUã•^}•Á~}•ÁK^@B^•ÁOíããÁV~}•&•ÁOíãããÁV~}•ããÁVUo@:ÁV~}•&•

Uãã~}•ÁV~}• ^	P~}•ÁV~}•ÁOíããÁOÁ~}• ^ Uí~}•ããÁ~}•}ã				Ô~}•ÁUd^c Y^•ãá~}•}ã				P~}•ÁV~}•ÁOíããÁOÁ~}• ^ P[í@ã[~}•}ã				Ô~}•ÁUd^c Oãããá~}•}ã				QãV~}•ãã
	Š^c	V@~}•	Uã @	Qí ÒV[ãã]	Š^c	V@~}•	Uã @	Qí ÒV[ãã]	Š^c	V@~}•	Uã @	Qí ÒV[ãã]	Š^c	V@~}•	Uã @	Qí ÒV[ãã]	
Èí K&EÁOÉ	G	HG	€	H	F	€	H	I	€	H	G	I€	F	€	€	F	íJ
Èí Kí ÁOÉ	I	HH	€	H	G	€	€	G	€	I	G	I I	G	G	F	í	íí
Èí K&EÁOÉ	€	íí	€	íí	€	F	F	G	€	H	G	H	I	F	€	€	Fé
Èí Kí ÁOÉ	H	íí	€	íí	H	€	í	í	€	íí	H	í€	í	€	€	í	FH
V[ãã]	J	Fíí	€	Fíí	í	F	J	Fí	€	FíG	J	FíF	Fí	H	F	FJ	I FG
Èí K&EÁOÉ	í	íí	€	íí	F	€	F	G	€	íH	G	íí	FF	€	G	FH	Fíí
Èí Kí ÁOÉ	F	íG	€	íH	G	€	€	G	€	íG	G	íí	J	G	H	Fí	FíH
Èí K&EÁOÉ	F	íí	€	íí	F	F	G	I	€	í€	J	íJ	F€	F	F	FG	F€
Èí Kí ÁOÉ	I	I H	€	Ií	H	€	€	H	€	íG	í	íí	J	€	€	J	Fíí
V[ãã]	Fí	Gí	€	G F	í	F	H	FF	€	Oé	Fí	Gí	HU	H	í	íí	íG
Ô:ãã ÁÁV[ãã]	GH	I Fí	€	I Hí	FH	G	FG	Gí	€	HíJ	Gí	I éí	íí	í	í	íí	JHí
Qí:ãã &OÁ	í Èí	Jí È	€	í È	í Èí	í È	í Èí	Á	€	JHÈ	í È	Á	í Èí	J	Féí	Á	Á
V[ãã]	Gí	Ií È	€	Ií È	FÈ	€	FÈ	Gí	€	I éí	Gí	I HÈ	í È	€	€	í È	í È
Uãã~}•ÁV~}• ^	GH	Gí	€	Gí	J	G	I	Fí	€	Gí	Gí	Gí	H	H	í	I H	ííG
Á ÁUãã~}•ÁV~}• ^	F€	íí È	€	íí È	íJÈ	F€	íí È	íí È	€	í€	Jí È	í€	íH	í€	íí È	íí È	í€
Ô:ãã ÁÁV~}• ^	€	íí	€	íí	€	€	€	€	€	í€	€	í€	F	€	F	G	Fí€
Á ÁUãã~}•ÁV~}• ^	€	Fí È	€	Fí È	€	€	€	€	€	Fí È	€	Fí È	Fí	€	Fí È	H	Fí È
Ô:ãã ÁÁV~}• ^	€	O€	€	O€	€	€	€	€	€	FG	€	FG	G	F	€	H	H
Á ÁUãã~}•ÁV~}• ^	€	I È	€	I È	€	€	€	€	€	H€	€	H	HÈ	Fí È	€	I È	HÈ
Ô:ãã ÁÁV~}• ^	€	íG	€	íG	€	€	€	€	€	íí	F	I J	í	€	€	í	Fí
Á ÁUãã~}•ÁV~}• ^	€	FJÈ	€	Fí È	€	€	€	€	€	F€	HÈ	F€	JÈ	€	€	í È	Fí È
Uo@:ÁV~}• ^	€	O€	€	O€	I	€	í	J	€	Gí	€	Gí	FG	G	€	Fí	íí
Á ÁUãã~}•ÁV~}• ^	€	I È	€	I È	HÈ	€	I FÈ	HÈ	€	í È	€	í È	GíG	HÈ	€	Gé	í È

Uãã~}•ÁV~}• ^	P~}•ÁV~}•ÁOíããÁOÁ~}• ^ Uí~}•ããÁ~}•}ã				Ô~}•ÁUd^c Y^•ãá~}•}ã				P~}•ÁV~}•ÁOíããÁOÁ~}• ^ P[í@ã[~}•}ã				Ô~}•ÁUd^c Oãããá~}•}ã				QãV~}•ãã
	Š^c	V@~}•	Uã @	Qí ÒV[ãã]	Š^c	V@~}•	Uã @	Qí ÒV[ãã]	Š^c	V@~}•	Uã @	Qí ÒV[ãã]	Š^c	V@~}•	Uã @	Qí ÒV[ãã]	
Uãã~}•ÁV~}• ^	Uãã~}•ÁV~}• ^	Uãã~}•ÁV~}• ^	Uãã~}•ÁV~}• ^	Uãã~}•ÁV~}• ^	Uãã~}•ÁV~}• ^	Uãã~}•ÁV~}• ^	Uãã~}•ÁV~}• ^	Uãã~}•ÁV~}• ^	Uãã~}•ÁV~}• ^	Uãã~}•ÁV~}• ^	Uãã~}•ÁV~}• ^	Uãã~}•ÁV~}• ^	Uãã~}•ÁV~}• ^	Uãã~}•ÁV~}• ^	Uãã~}•ÁV~}• ^	Uãã~}•ÁV~}• ^	Uãã~}•ÁV~}• ^
Èí Kí ÁOÉ	H	íí	€	íí	3	€	5	8	€	57	H	60	í	€	€	í	Fíí
Èí K&EÁOÉ	8	78	€	86	F	€	F	G	€	íH	G	íí	11	€	G	FH	156
Èí Kí ÁOÉ	F	íG	€	íH	G	€	€	G	€	íG	G	íí	J	2	3	14	FíH
Èí K&EÁOÉ	F	íí	€	íí	F	1	G	I	€	í€	G	9	F€	F	F	FG	F€
V[ãã]K[í~}• ^	FH	Gí	€	Gí	í	F	í	Fí	€	GíG	Fí	Gí	Hí	H	í	íí	ííí
Á ÁUãã~}•ÁV~}• ^	í È	Jí È	€	Á	I HÈ	í È	í€	Á	€	JH	í	Á	í È	í È	F€	Á	Á
U P O	È é	È í	È €€	È F	È H	È €	È €€	È €€	È€€	È H€	È í	È í€	È í	È í	È €€	È HU	È í

Ô[~}•ÔM|ãããã&E
 UUÔj cA FFI
 Ô[!|}ããããGii
 QIFDGiEgi

Ôã Á -S[]*A^ãã@
 BBUK^)^!^AQ|ããA^)^^
 OBY KÔ^)}ãUd^^c
 Y^ãã@:KÁ"}^}^

ÔP^Aã^ KSOOP.ÖÖÖÖE
 Úã^AÔ[ãã KEEEEEEF
 Úãã^Oãã KGBJDEFG
 Úãã^A[KGC

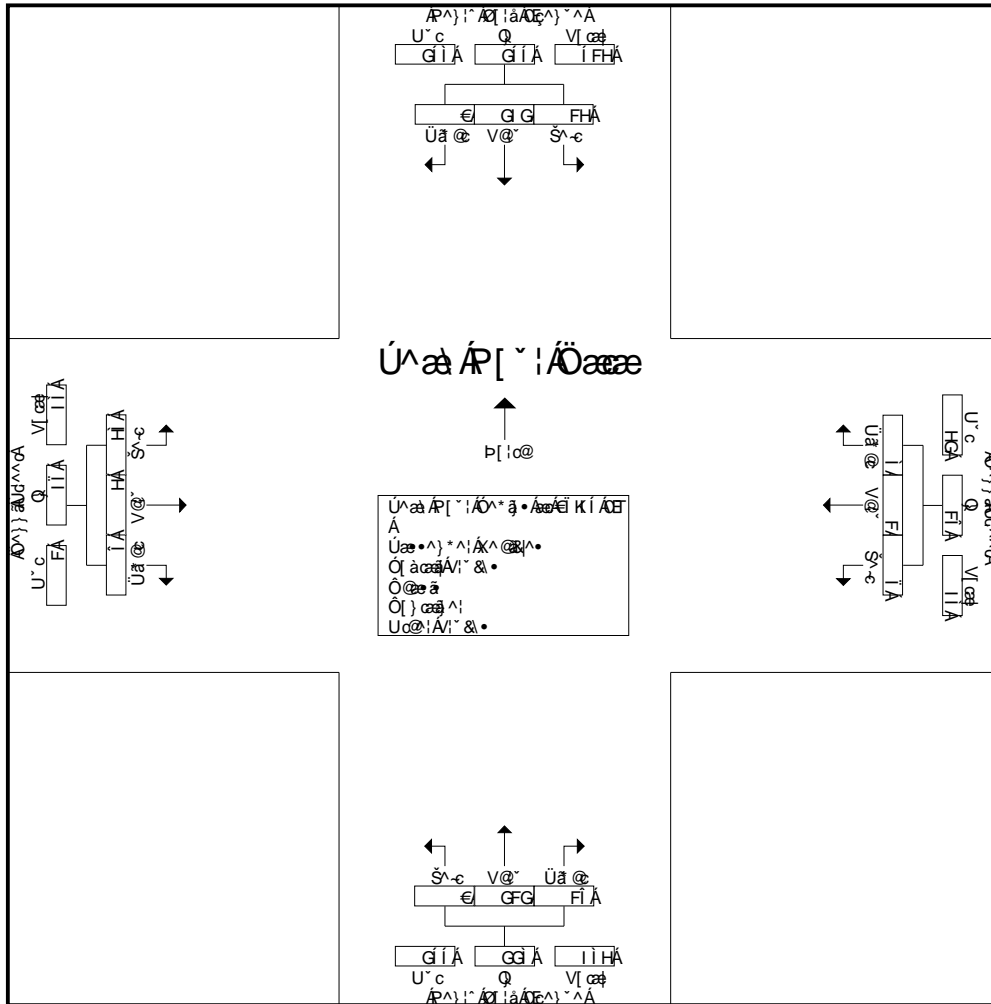

Úãã ÁP[~!Açãã•ããA[! Aí Kí ÁB Áí Aí Kí ÁB ÁU^ãã ÁF ÁF
 Úãã ÁP[~!A[! Öãã@Q[!|}ãã@A^ãã•AãK

ÉéÁ ã•È	H	íí	€	îF	3	€	5	8	€	57	H	60	ì	€	€	ì
ÉFí Á ã•È	8	78	€	86	F	€	F	G	€	íH	G	íí	11	€	G	FH
ÉHé Á ã•È	F	íG	€	îH	G	€	€	G	€	íG	G	íI	J	2	3	14
Éíí Á ã•È	F	II	€	II	F	1	G	I	€	í€	9	íJ	F€	F	F	FG
V[çããK[!^	FH	GG	€	Gí	í	F	í	Fí	€	GFG	Fí	GG	H	H	í	íí
Á ÁB[!V[çãã	íÈ	JiÈ	€	Á	IÈ	íÈ	í€	Á	€	JH	í	Á	ì€	îÈ	FçÈ	Á
ÚPÖ	È€	Èí	È€€	ÈíF	ÈíH	Èí€	Èí€€	Èí€€	È€€€	ÈíH€	ÈíI	Èí€	ÈíI	Èíí	Èí€€	ÈíH

Ó[~}•ÁM|ãããÁQ&É
 UUÁQ|cÁFíí
 Ó[!|}ãããÁGíí
 Q|FÁGíÉGí

Óã Á -Á[] *Á^ãã@
 ÞÉU|K|P^)^!^ ÁQ |ãÁQÉ^)^ ^
 ÖEY KÁÖ^}) ãUd^^c
 Y ^ãã@:KÁU^}}^

ÖE^ Á pã ^ K&ÓÓP.ÖÖÖÖE
 Úã ÁÖ[á^ K&E&E&E&E&E&E&E
 ÚããcÁÖãã K&G&J&B&E&F&G
 Úãã^Áp[K&G

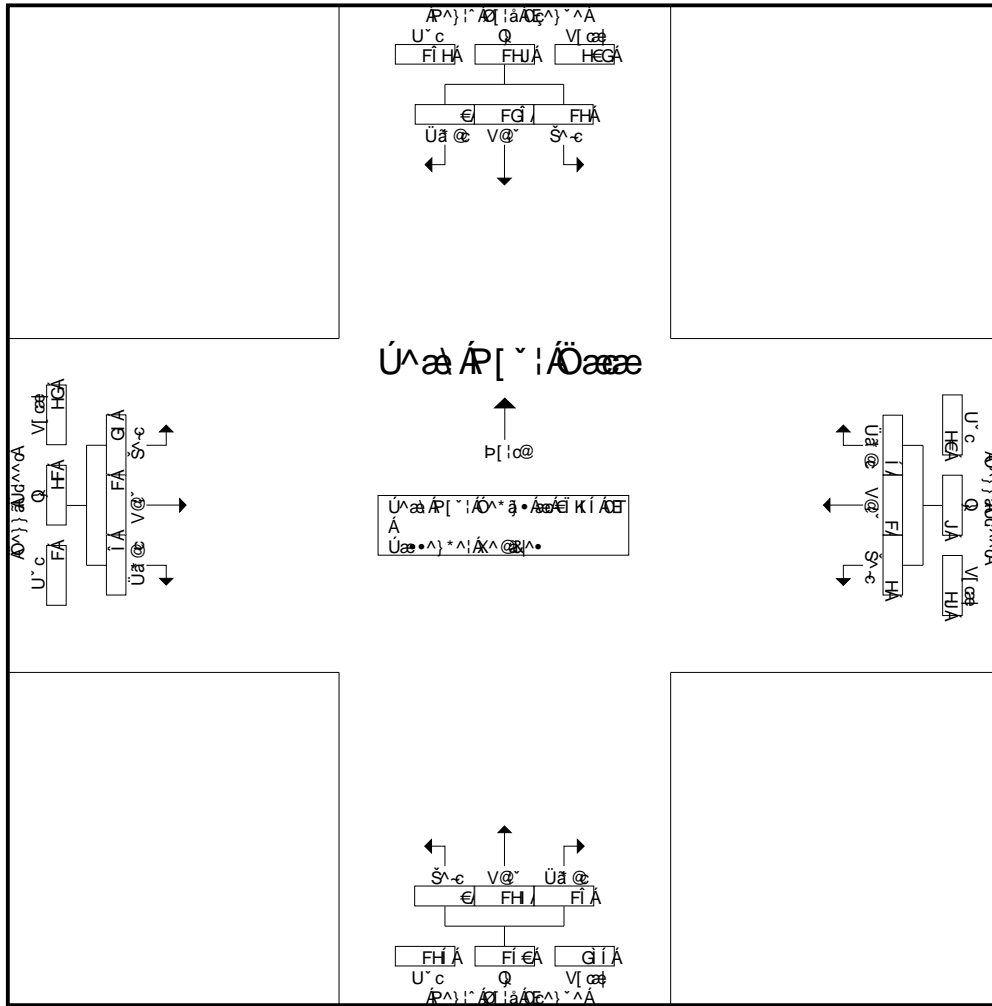

Ú^ãã ÁP[~!ÖÖããã
 Ú^ãã ÁP[~!Á|ÖÖããã!|ãã@Ö^ãã•ÁãK

ÉéÁ ä•È	H	HH	€	Hí	2	€	5	7	€	42	H	45	l	€	€	l
ÉFí Á ä•È	8	44	€	52	F	€	€	F	€	HH	G	Hí	7	€	G	J
ÉHEÁ ä•È	F	GJ	€	H€	€	€	€	€	€	HH	G	Hí	í	1	3	11
Éí Á ä•È	F	G€	€	Gf	€	1	€	F	€	G	9	Hí	í	€	F	í
V cããK ~!^	FH	FQ	€	FHU	H	F	í	J	€	FH	Fí	Fí€	G	F	í	HF
Á ÁQ ÉV cãã	JÉ	JéÉ	€	Á	HÉH	FFÉ	ííÉ	Á	€	íJÉH	FéÉ	Á	ííÉ	H€	FJÉ	Á
ÚPÖ	ÉÉ	ÉFí	É€€	Éíí	Éíí	É€	É€	É€f	É€€	ÉÉJí	Éíí	ÉÉH	Éíí	É€	É€€	Éé

Ó[~]•ÁM|ããÁQ&É
 UUÁQcÁFIÍ
 Ó[~]ããÓÓãGíí
 QIFDQíÉí

Óã Á-Á[~]*Á^ãã@
 PÁKÁ^|~ÁQ|ãÁQ^~^
 ÓEY KÁ^}ãÁUd^^c
 Y^ãã@:KÁ^}}^

ÓE^Áã^ KÓÓP.ÓÓÓE
 ÚãÁQ|ã KÉÉÉÉÉÉÉÉÉÉ
 ÚããÓãã KÁB.ÉBÉFG
 Úã^Á[KÉ

Ó[~]•ÁU:ããÁÓIããÁV~&•

ÚããÁV^	P^} ~ÁQ ãÁQ^~^ U ~cã[~]ã				Ö^}}ãUd^^c Y^•cã[~]ã				P^} ~ÁQ ãÁQ^~^ P :cã[~]ã				Ö^}}ãUd^^c Öãcã[~]ã				Q.dÁV cã
	Š^c	V@~	Uã@	Q ÉV cã	Š^c	V@~	Uã@	Q ÉV cã	Š^c	V@~	Uã@	Q ÉV cã	Š^c	V@~	Uã@	Q ÉV cã	
Éi KÉÁQÉ	€	H	€	H	€	€	€	€	€	H	€	H	€	€	€	€	í
Éi KÍ ÁQÉ	€	í	€	í	€	€	€	€	€	J	€	J	€	€	F	F	Fí
Éi KÉÁQÉ	€	í	€	í	€	€	€	€	€	í	€	í	€	€	€	€	F€
Éi KÍ ÁQÉ	€	FG	€	FG	€	€	€	€	€	í	€	í	€	€	€	€	FJ
V cã	€	G	€	G	€	€	€	€	€	G	€	G	€	€	F	F	íH
Éi KÉÁQÉ	€	FI	€	FI	€	€	€	€	€	FG	€	FG	€	€	€	€	G
Éi KÍ ÁQÉ	€	FG	€	FG	€	€	€	€	€	FH	€	FH	€	€	€	€	G
Éi KÉÁQÉ	€	í	€	í	€	€	€	€	€	FF	€	FF	F	€	€	F	FJ
Éi KÍ ÁQÉ	€	í	€	í	€	€	€	€	€	F€	€	F€	€	€	€	€	Fí
V cã	€	í€	€	í€	€	€	€	€	€	íí	€	íí	F	€	€	F	íí
Ó:ããÁV cã	€	íí	€	íí	€	€	€	€	€	í€	€	í€	F	€	F	G	Fí€
Q :ããÁV cã	€	F€€	€	Á	€	€	€	€	€	F€€	€	Á	í€	€	í€	Á	Á
V cãÁ	€	ííÉ	€	ííÉ	€	€	€	€	€	í€	€	í€	Éí	€	Éí	FÉ	

ÚããÁV^	P^} ~ÁQ ãÁQ^~^ U ~cã[~]ã				Ö^}}ãUd^^c Y^•cã[~]ã				P^} ~ÁQ ãÁQ^~^ P :cã[~]ã				Ö^}}ãUd^^c Öãcã[~]ã				Q.dÁV cã
	Š^c	V@~	Uã@	Q ÉV cã	Š^c	V@~	Uã@	Q ÉV cã	Š^c	V@~	Uã@	Q ÉV cã	Š^c	V@~	Uã@	Q ÉV cã	
U^ããÁV ~ ÁQ ãã•ãÁQ {Ái KÍ ÁQÉ Ái KÉÁQÉ ÁU^ããÁV ~ ÁQ ãã																	
U^ããÁV ~ ÁQ ãã•ãÁQ ããÁQ ãã•ÁQ ããÁQ ãã																	
Éi KÍ ÁQÉ	€	FG	€	FG	€	€	€	€	€	í	€	í	€	€	€	€	FJ
Éi KÉÁQÉ	€	14	€	14	€	€	€	€	€	FG	€	FG	€	€	€	€	26
Éi KÍ ÁQÉ	€	FG	€	FG	€	€	€	€	€	13	€	13	€	€	€	€	G
Éi KÉÁQÉ	€	í	€	í	€	€	€	€	€	FF	€	FF	1	€	€	1	FJ
V cãÁV ~ ÁQ ãã	€	íí	€	íí	€	€	€	€	€	íH	€	íH	F	€	€	F	íJ
ÁÁQ ããÁV cã	€	F€€	€	Á	€	€	€	€	€	F€€	€	Á	F€€	€	€	Á	Á
UPØ	€€€€	Éí	€€€€	Éí	€€€€	€€€€	€€€€	€€€€	€€€€	ÉíG	€€€€	ÉíG	€í€	€€€€	€€€€	€í€	Éíí

Ó[~},oÁM|ã,ãããQ&E
 UUÁQ,cÁFII
 Ó[!|}ããÖÖÁGII
 Q|FDG|ÈG|

Óã Á -Á[] * Á^ãã@
 ÞEUIK^)^!^ ÁQ|ãÁE^)^^
 ÖEY KÁO^})ãUd^^c
 Y^ãã@:KÁU^})^

ÖE^Áãã^ KÖÓOP.ÖÖÖÖE
 Úã^ÁQ|ã^ KEEEEEEEF
 ÚããcÁÖãã KÖEJHBEFG
 Úãã^Á[KÖ

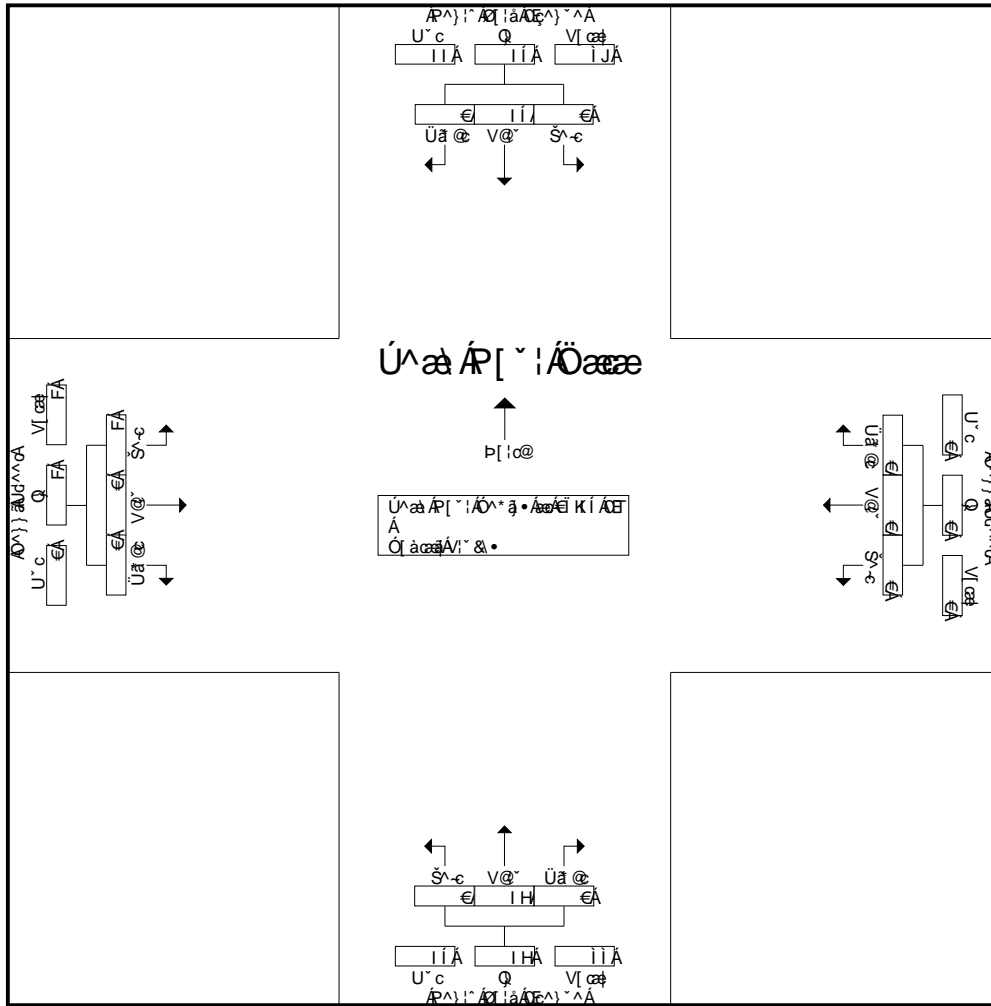

Úãã ÁP[~!ÖÖããã
 Úãã ÁP[~!Á|ÖÖÁQ|!|ããÖÖÁ^ããK

	éí Á ä È				éí Á ä È				éí Á ä È				éí Á ä È			
ÉÉÁ ä È	€	FG	€	FG	€	€	€	€	€	í	€	í	€	€	€	€
ÉFÁ ä È	€	14	€	14	€	€	€	€	€	FG	€	FG	€	€	€	€
ÉHÁ ä È	€	FG	€	FG	€	€	€	€	€	13	€	13	€	€	€	€
ÉIÁ ä È	€	í	€	í	€	€	€	€	€	FF	€	FF	1	€	€	1
V öãK {^	€	IÍ	€	IÍ	€	€	€	€	€	IH	€	IH	F	€	€	F
Á ÁH EÁV öã	€	FEE	€	Á	€	€	€	Á	€	FEE	€	Á	FEE	€	€	Á
UPÖ	€€€	ÈE	€€€	ÈE	€€€	€€€	€€€	€€€	€€€	ÈG	€€€	ÈG	ÈE	€	€€€	ÈE

Ó[~}oÁM|ããáÁQ&É
 UUÁOj cÁFI I
 Ó[~}ãáÁQ&É I
 QI FDI Ë Ë I

Óã Á -Á[] * Á^ã&@
 PÁUjP^} í ÁQ |ãÁQ^} ^
 ÓEY KÁ^} } áUd^c
 Y ^ã&@:KÁU } } ^

ÓE^ Áã ^ K&ÓOP.ÓÓÓE
 Úã ÁO[á^ K&E&E&E&E&E
 Úã&ÁOã K&E&E&E&E&E
 Úã^ ÁP[K&E

Ó[~} • ÁUjããáÁQ&É

Úã&ÁQ^ ^	P^} í ÁQ ãÁQ^} ^ Uí^ cã[~} á				Ö^} } áUd^c Y ^• cã[~} á				P^} í ÁQ ãÁQ^} ^ P[~} cã[~} á				Ö^} } áUd^c Óã cã[~} á				Q dÁV[cã
	Š^c	V@^	Uã @	Qj ÉV[cã	Š^c	V@^	Uã @	Qj ÉV[cã	Š^c	V@^	Uã @	Qj ÉV[cã	Š^c	V@^	Uã @	Qj ÉV[cã	
Éi K&E&E&E	€	F	€	F	€	€	€	€	€	€	€	€	€	€	€	€	F
Éi K&E&E	€	F	€	F	€	€	€	€	€	F	€	F	€	F	€	€	H
Éi K&E&E	€	F	€	F	€	€	€	€	€	€	€	€	€	€	€	€	F
Éi K&E&E	€	I	€	I	€	€	€	€	€	F	€	F	F	€	€	€	Í
V[cã	€	I	€	I	€	€	€	€	€	G	€	G	F	F	€	G	FF
Éi K&E&E	€	F	€	F	€	€	€	€	€	€	€	€	€	€	€	€	F
Éi K&E&E	€	I	€	I	€	€	€	€	€	G	€	G	F	€	€	F	F€
Éi K&E&E	€	G	€	G	€	€	€	€	€	I	€	I	€	€	€	€	Í
Éi K&E&E	€	H	€	H	€	€	€	€	€	H	€	H	€	€	€	€	Í
V[cã	€	FH	€	FH	€	€	€	€	€	F€	€	F€	F	€	€	F	G
Ó[ã] áÁ[cã	€	OE	€	OE	€	€	€	€	€	FG	€	FG	G	F	€	H	HÍ
Qj ÉV[cã	€	F€€	€	Á	€	€	€	Á	€	F€€	€	Á	Í Ë	H€H	€	Á	Á
V[cã	€	Í Ë	€	Í Ë	€	€	€	€	€	H€H	€	H€H	Í Ë	OE	€	Í Ë	

Úã&ÁQ^ ^	P^} í ÁQ ãÁQ^} ^ Uí^ cã[~} á				Ö^} } áUd^c Y ^• cã[~} á				P^} í ÁQ ãÁQ^} ^ P[~} cã[~} á				Ö^} } áUd^c Óã cã[~} á				Q dÁV[cã
	Š^c	V@^	Uã @	Qj ÉV[cã	Š^c	V@^	Uã @	Qj ÉV[cã	Š^c	V@^	Uã @	Qj ÉV[cã	Š^c	V@^	Uã @	Qj ÉV[cã	
U^ã ÁP[~} :ÁQ]ãã • á ÁQ[{ ÁE K&E&E ÁE K&E&E ÁU^ã ÁÁ -Á																	
U^ã ÁP[~} :ÁQ]ãã • á ÁQ[{ ÁE K&E&E ÁE K&E&E ÁU^ã ÁÁ -Á																	
Éi K&E&E	€	I	€	I	€	€	€	€	€	F	€	F	1	€	€	1	Í
Éi K&E&E	€	F	€	F	€	€	€	€	€	€	€	€	€	€	€	€	F
Éi K&E&E	€	7	€	7	€	€	€	€	€	G	€	G	F	€	€	F	10
Éi K&E&E	€	G	€	G	€	€	€	€	€	5	€	5	€	€	€	€	Í
V[cã] K[~} { ^	€	FI	€	FI	€	€	€	€	€	I	€	I	G	€	€	G	G
Á ÁQ] ÉV[cã	€	F€€	€	Á	€	€	€	Á	€	F€€	€	Á	F€€	€	€	Á	Á
UPØ	€€€	€€	€€€	€€	€€€	€€€	€€€	€€€	€€€	€€	€€€	€€	€€	€€€	€€€	€€	€€

Ó[] º ÁM [ã ä] ÁQ&É
 UUÁQ º ÁFIÍ
 Ó[] º ÁQ&ÉFIÍ
 QI FÁQ I É É I

Óã Á -Á[] * ÁQ&É@
 ÞÉU[KP^] : ÁQ [ã] ÁQ&É^ ^
 ÖEY KÁO^ } äUd^^c
 Y ^æ@ : KÁU^ } } ^

ÖE^ Á þã ^ K&ÓÓP.ÖÖÓÖE
 Úã ÁQ [ã] K&ÉÉÉÉÉÉF
 Úæ º ÁQ&É K&G&J&B&E&F&G
 Úæ ^ ÁQ [ã] K&G

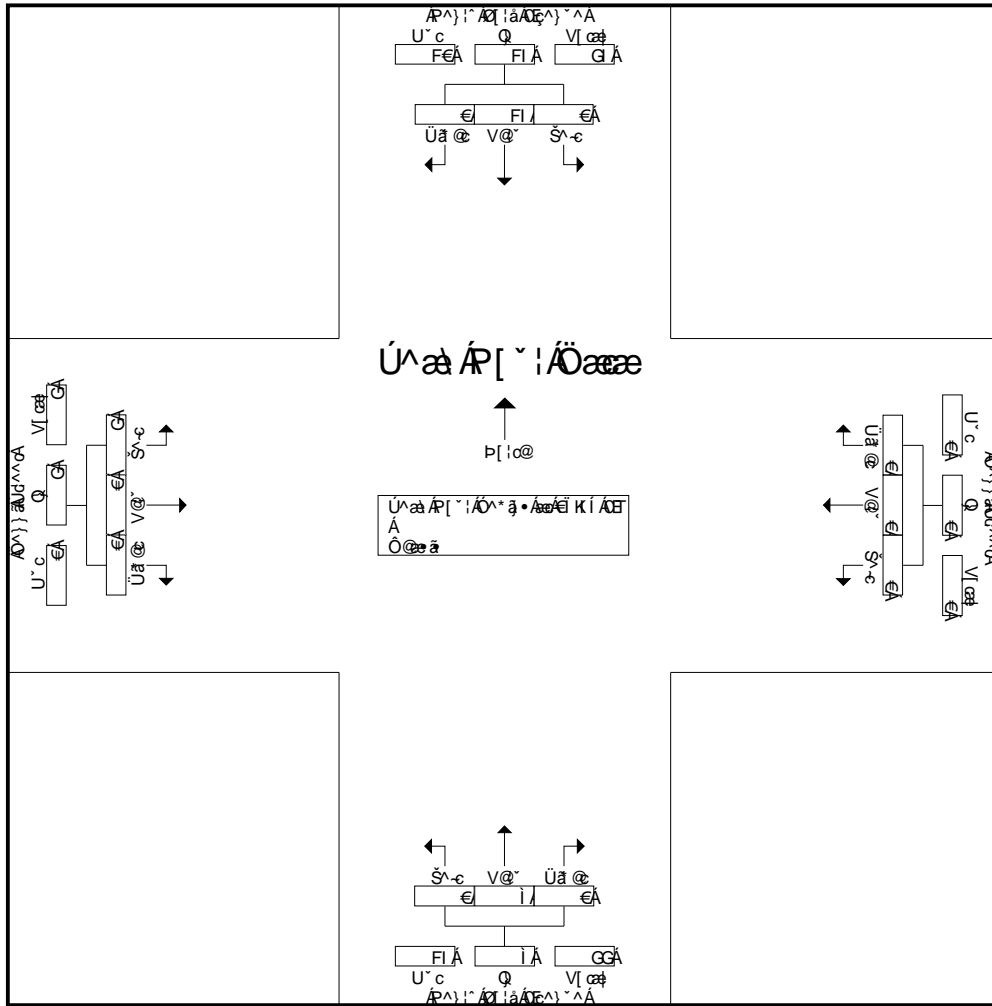

Úã ÁQ [ã] ÁQ&É º ÁQ [ã] ÁQ&É KÁI ÁQ&É ÁQ&É K&ÁQ&É ÁQ&É Úã ÁQ&É ÁQ&É
 Úã ÁQ [ã] ÁQ [ã] ÁQ&ÉFIÍ º ÁQ&ÉFIÍ º ÁQ&ÉFIÍ

	é k í ÁQ&É				é k í ÁQ&É				é k í ÁQ&É				é k í ÁQ&É			
ÉÉÁ ä • É	€	I	€	I	€	€	€	€	€	F	€	F	1	€	€	1
ÉFÍ Á ä • É	€	F	€	F	€	€	€	€	€	€	€	€	€	€	€	€
ÉHEÁ ä • É	€	7	€	7	€	€	€	€	€	G	€	G	F	€	€	F
ÉÍ Á ä • É	€	G	€	G	€	€	€	€	€	5	€	5	€	€	€	€
VI æK [] ^	€	FI	€	FI	€	€	€	€	€	i	€	i	G	€	€	G
Á ÁQ [ã] ÁQ&É	€	F&É	€	Á	€	€	€	€	€	F&É	€	Á	F&É	€	€	Á
UPÖ	€€€	€ €	€€€	€ €	€€€	€€€	€€€	€€€	€€€	€ €	€€€	€ €	€ €	€€€	€€€	€ €

Ö[~]•ÁUjãããÖ}cã^
 UUÁÖcÁFíí
 Ö[~]ãÖÖcãGíí
 QíFDGíEí

Öã Á-Á[~]*ÁÖãã@
 ÞÖUíKÁ^í^ÁÖíãÁÖ^~^
 ÖEY KÁ^}ãUd^^c
 Y^ãã@:KÁ^}^

ÖE^Áã^ KÖÓÖPÖÖÖÖE
 ÚãÁÖíã KÖÖÖÖÖÖE
 ÚcãÖÖã KÖÖÖÖEFG
 Úã^Á[KÖ

Ö[~]•ÁUjãããÖ}cã^

ÚcãÖÁã^	P^}í^ÁÖíãÁÖ^~^ Uí^cã[~]ã				Ö^}ãUd^^c Y^•cã[~]ã				P^}í^ÁÖíãÁÖ^~^ P[í]cã[~]ã				Ö^}ãUd^^c Öãcã[~]ã				QdÁV[~]cã
	Š^c	V@^	Uã@	Öí]ÉV[~]cã	Š^c	V@^	Uã@	Öí]ÉV[~]cã	Š^c	V@^	Uã@	Öí]ÉV[~]cã	Š^c	V@^	Uã@	Öí]ÉV[~]cã	
Éí KÉÖÖE	€	í	€	í	€	€	€	€	€	í	F	í	€	€	€	€	FH
Éí KÍ ÁÖE	€	í	€	í	€	€	€	€	€	í	€	í	F	€	€	F	Fí
Éí KÉÁÖE	€	Fí	€	Fí	€	€	€	€	€	G	€	G	€	€	€	€	Fí
Éí KÍ ÁÖE	€	í	€	í	€	€	€	€	€	í	€	í	F	€	€	F	FH
V[~]cã	€	HG	€	HG	€	€	€	€	€	GH	F	G	G	€	€	G	íí
Éí KÉÁÖE	€	Fí	€	Fí	€	€	€	€	€	í	€	í	F	€	€	F	GG
Éí KÍ ÁÖE	€	FG	€	FG	€	€	€	€	€	í	€	í	€	€	€	€	Fí
Éí KÉÁÖE	€	FG	€	FG	€	€	€	€	€	í	€	í	€	€	€	€	Fí
Éí KÍ ÁÖE	€	FF	€	FF	€	€	€	€	€	F€	€	F€	G	€	€	G	GH
V[~]cã	€	í€	€	í€	€	€	€	€	€	G	€	G	H	€	€	H	íí
Ö[~]ãÁÁ[~]cã	€	íG	€	íG	€	€	€	€	€	íí	F	íJ	í	€	€	í	FH
Ö[~]í:ÖÁ	€	F€€	€	Á	€	€	€	Á	€	Jí	G	Á	F€€	€	€	Á	Á
V[~]cãÁ	€	í€H	€	í€H	€	€	€	€	€	HíH	€H	H	H€	€	€	H€	

ÚcãÖÁã^	P^}í^ÁÖíãÁÖ^~^ Uí^cã[~]ã				Ö^}ãUd^^c Y^•cã[~]ã				P^}í^ÁÖíãÁÖ^~^ P[í]cã[~]ã				Ö^}ãUd^^c Öãcã[~]ã				QdÁV[~]cã
	Š^c	V@^	Uã@	Öí]ÉV[~]cã	Š^c	V@^	Uã@	Öí]ÉV[~]cã	Š^c	V@^	Uã@	Öí]ÉV[~]cã	Š^c	V@^	Uã@	Öí]ÉV[~]cã	
U^ãÁP[~]í:ÁÖãã•ãÁÖ[~]Áí KÍ ÁÖE Áí KÉÁÖE ÁU^ãÁÁ-Á																	
U^ãÁP[~]í:Áí:ÁÖ)ã^ÁÖc!^&ç}ÁÖ^ã•ÁãÁí KÍ ÁÖE																	
Éí KÍ ÁÖE	€	í	€	í	€	€	€	€	€	7	€	7	1	€	€	1	FH
Éí KÉÁÖE	€	15	€	15	€	€	€	€	€	í	€	í	F	€	€	F	22
Éí KÍ ÁÖE	€	FG	€	FG	€	€	€	€	€	í	€	í	€	€	€	€	Fí
Éí KÉÁÖE	€	FG	€	FG	€	€	€	€	€	í	€	í	€	€	€	€	Fí
V[~]cãÁ[~]í^	€	íí	€	íí	€	€	€	€	€	GG	€	GG	G	€	€	G	íí
Á ÁÖ[~]ÉV[~]cã	€	F€€	€	Á	€	€	€	Á	€	F€€	€	Á	F€€	€	€	Á	Á
UPÖ	€€€	€€€	€€€	€€€	€€€	€€€	€€€	€€€	€€€	€íí	€€€	€íí	€€€	€€€	€€€	€€€	€íH

Ó[] , o ÁM | a a a Q & E
 UUÁQ c A F I I
 Ó[] : } a a Q a G i i
 Q I F D G i E d i

Óa: Á -Á[] * ÁO^as@
 P E U I K P ^) : ^ A Q | a a Q E ^) ^ ^
 O E Y K O ^) } a U d ^ ^ c
 Y ^ a a @ : K A U ^) } } ^

Q E ^ Á P a a ^ K S O O P Q O O C E F
 U a a Á O [a ^ K E E E E E E E F
 U a a a O a a ^ K C R U J B D E F G
 U a a ^ Á P [K G

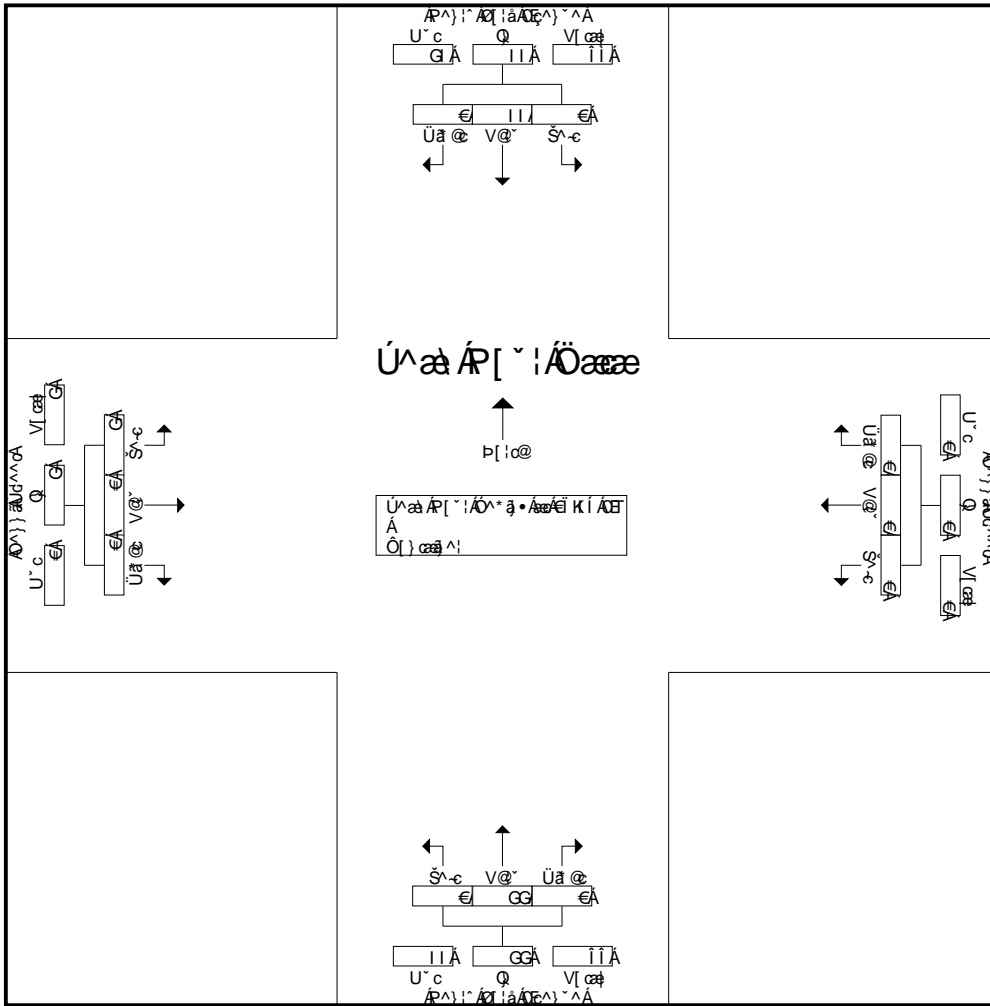

Úaá ÁP[] : ÁÖaæe • a ÁQ [] Á E K I Á E Á Á K E Á E Á U a a Á Á - Á
 Úaá ÁP[] : ÁÖaæe [] : } a a Q a G i i • Á a K

	eí k i Á E				eí k i Á E				eí k i Á E				eí k i Á E			
É e Á a • È	€	í	€	í	€	€	€	€	€	7	€	7	1	€	€	1
É F I Á a • È	€	15	€	15	€	€	€	€	€	i	€	i	F	€	€	F
É H E Á a • È	€	FG	€	FG	€	€	€	€	€	i	€	i	€	€	€	€
É I Á a • È	€	FG	€	FG	€	€	€	€	€	i	€	i	€	€	€	€
V I a a K [] ^	€	II	€	II	€	€	€	€	€	GG	€	GG	G	€	€	G
Á Á E [] V I a a	€	FEE	€	Á	€	€	€	€	€	FEE	€	Á	FEE	€	€	Á
U P O	€€€	€€€	€€€	€€€	€€€	€€€	€€€	€€€	€€€	€€€	€€€	€€€	€€€	€€€	€€€	€€€

Ó[~}•ÁV|ã ä^áQ&É
 UUÁÖ çÁFIÍ
 Ó[{}]ãËÖÖÁGÍÍ
 QIFDÖÍËÍ

Óã Á-Á[~}•Á^ã&@
 ÞEUIKÁ^}Í ÁQ |ãÁÖ^}^
 ÖEY KÁ^}ãÁÖd^^c
 Y^ã&@:KÁ^}~}^

ÖÁ^Áã^ KÖÓÖP.ÖÖÖÖE
 Úã^ÁÖ|ã^ KÖÖÖÖÖÖE
 Úã^ÁÖã^ KÖÖÖÖÖEFG
 Úã^ÁÖ[KÖ

Ö[~}•ÁV|ã ä^áQ&É

Úã^ÁÖ ã^	P^}Í ÁQ ãÁÖ^}^ UÍ^cã[~}^á				Ö^}ãÁÖd^^c Y^•cã[~}^á				P^}Í ÁQ ãÁÖ^}^ P[{}cã[~}^á				Ö^}ãÁÖd^^c Öãcã[~}^á				Q çÁV çã
	Š^c	V@^	Úã @	Ö ÆV çã	Š^c	V@^	Úã @	Ö ÆV çã	Š^c	V@^	Úã @	Ö ÆV çã	Š^c	V@^	Úã @	Ö ÆV çã	
ÈI KÖÖÖE	€	F	€	F	€	€	F	F	€	I	€	I	F	€	€	F	I
ÈI KÍ ÁÖE	€	€	€	€	€	€	€	€	€	G	€	G	€	€	€	€	G
ÈI KÍ ÁÖE	€	I	€	I	€	€	F	F	€	I	€	I	€	€	€	€	FG
ÈI KÍ ÁÖE	€	I	€	I	F	€	€	F	€	€	€	€	G	€	€	€	I
V çã	€	J	€	J	F	€	G	H	€	FH	€	FH	H	€	€	H	G
ÈI KÖÖÖE	€	I	€	I	€	€	F	F	€	G	€	G	H	€	€	H	FE
ÈI KÍ ÁÖE	€	G	€	G	G	€	€	G	€	€	€	€	F	F	€	G	I
ÈI KÍ ÁÖE	€	H	€	H	F	€	G	H	€	H	€	H	H	F	€	I	FH
ÈI KÍ ÁÖE	€	G	€	G	€	€	€	€	€	H	€	H	G	€	€	G	I
V çã	€	FF	€	FF	H	€	H	I	€	I	€	I	J	G	€	FF	H
Ö ã áÁV çã	€	ÖE	€	ÖE	I	€	I	J	€	GF	€	GF	FG	G	€	FI	I
Ö ã &ÖÁ	€	FEE	€	Á	I	€	I	Á	€	FEE	€	Á	I	I	€	Á	Á
V çãÁ	€	HFEG	€	HFEG	I	€	I	FI	€	HGE	€	HGE	FI	HE	€	GF	Á

Úã^ÁÖ ã^	P^}Í ÁQ ãÁÖ^}^ UÍ^cã[~}^á				Ö^}ãÁÖd^^c Y^•cã[~}^á				P^}Í ÁQ ãÁÖ^}^ P[{}cã[~}^á				Ö^}ãÁÖd^^c Öãcã[~}^á				Q çÁV çã
	Š^c	V@^	Úã @	Ö ÆV çã	Š^c	V@^	Úã @	Ö ÆV çã	Š^c	V@^	Úã @	Ö ÆV çã	Š^c	V@^	Úã @	Ö ÆV çã	
U^ã ÁP[~}Í ÁÖ ã^ã^ã ÁQ[{} ÁE KÍ ÁÖE ÁE KÍ ÁÖE ÁU^ã ÁP[~}Í ÁÖ ã^ã^ã																	
U^ã ÁP[~}Í ÁÖ ã^ã^ã ÁQ[{} ÁE KÍ ÁÖE ÁE KÍ ÁÖE ÁU^ã ÁP[~}Í ÁÖ ã^ã^ã																	
ÈI KÍ ÁÖE	€	4	€	4	F	€	€	F	€	€	€	€	G	€	€	G	I
ÈI KÖÖÖE	€	I	€	I	€	€	F	F	€	G	€	G	3	€	€	H	FE
ÈI KÍ ÁÖE	€	G	€	G	2	€	€	G	€	€	€	€	F	1	€	G	I
ÈI KÍ ÁÖE	€	H	€	H	F	€	2	3	€	3	€	3	H	F	€	4	13
V çãÁV çã	€	FH	€	FH	I	€	H	I	€	I	€	I	J	G	€	FF	H
Á ÁÖ ã^ã^ã	€	FEE	€	Á	I	€	I	Á	€	FEE	€	Á	I	I	€	Á	Á
UPØ	€€€	È FH	€€€	È FH	È €€	€€€	È I	È I H	€€€	È FI	€€€	È FI	È I €	È €€	€€€	È I	È JG

Ó[~}•ÁM|ãããÁQ&É
 UUÁQ|cÁFíí
 Ó[!|}ããÓÁGíí
 Q|FÁG|Éíí

Óã Á -Á[]*Á^ãã@
 ÞÉU|K|P^)^!^ÁQ|!ãÁQÉ^)^^
 ÓEY KÁÓ^})ãUd^^c
 Y^ãã@!KÁ^})}^

ÓE^ÁPã^ K&ÓÓP.ØÖÓCE
 Úã^ÁQ|ã^ K&E&E&E&E&E&E&E&E
 Úãã^Óãã^ K&C&B|D&E&F&G
 Úãã^ÁP| K&G

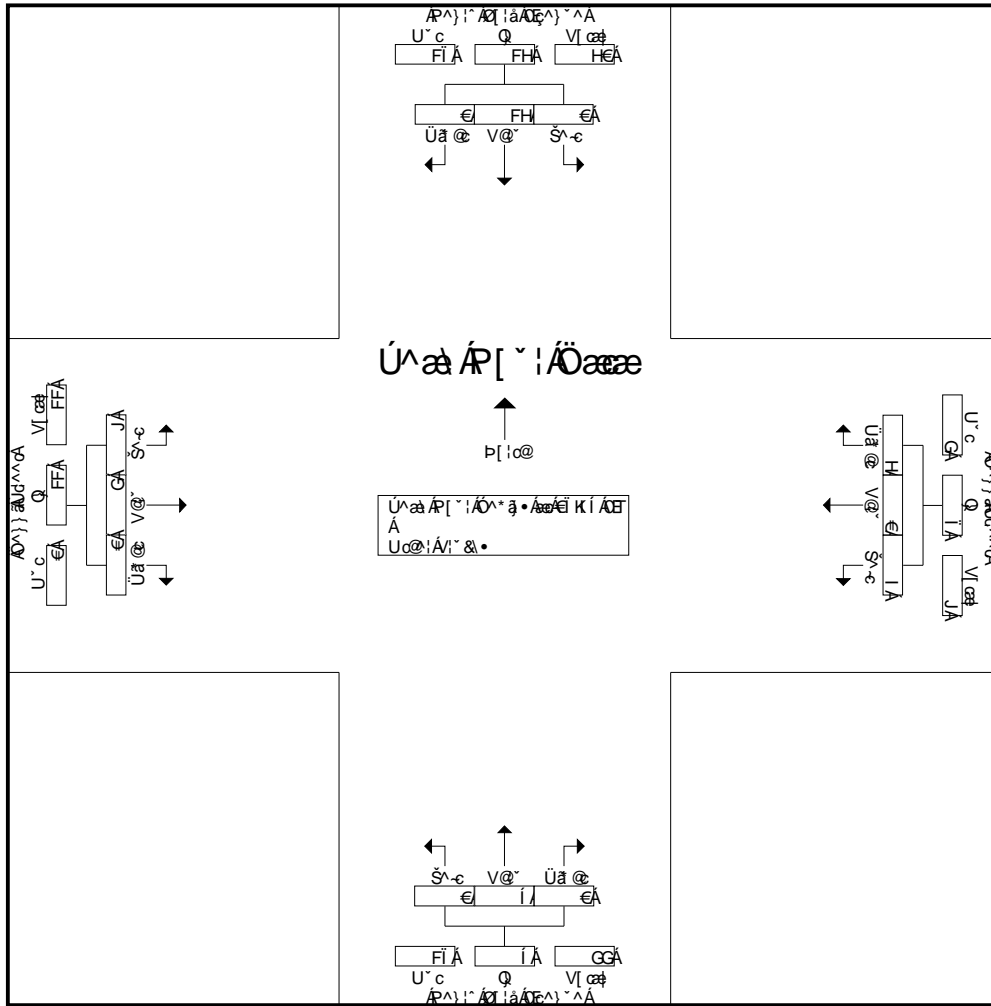

Úãã ÁP[~!ÁQãã•ãÁQ|! Kí Kí ÁQÉ Á Á K&ÁQÉ ÁÚãã ÁÁÁ Á
 Úãã ÁP[~!Á!ÁQããQ|!|ããÓÁ^ã•ÁãK

	éí kí ÁQÉ				éí kí ÁQÉ				éí kí ÁQÉ				éí kí ÁQÉ			
ÉéÁ á•É	€	4	€	4	F	€	€	F	€	€	€	€	G	€	€	G
ÉFí Á á•É	€	I	€	I	€	€	F	F	€	G	€	G	3	€	€	H
ÉHÉÁ á•É	€	G	€	G	2	€	€	G	€	€	€	€	F	1	€	G
Éí Á á•É	€	H	€	H	F	€	2	3	€	3	€	3	H	F	€	4
V cãK ~{^	€	FH	€	FH	I	€	H	í	€	í	€	í	J	G	€	FF
Á ÁQ ÉV cã	€	F&€	€	Á	ííÉ	€	I&€	Á	€	F&€	€	Á	ííÉ	FíÉ	€	Á
ÚPØ	€€€	É FH	€€€	É FH	É€€	€€€	Éí	Éí H	€€€	Éí Fí	€€€	Éí Fí	Éí€	É€€	€€€	Éíí

Ó[~}oÁM|ãããQ&E
 UUÁQ|cÁFFI
 Ó[!|}ããããGii
 Q|FÁG|EÁI

Óã Á -Á[] * Á^ãã@
 ÞEUIKÁ^| ÁQ |ãÁQ^|^
 ÖEY KÁO^}}ãUd^^c
 Y^ãã@:KÁ^}}^

ÖÁ^Áãã ^ KÖÓOP.ÖÖÖT Ö
 ÚãÁQ|ãã KEEEEEEF
 ÚããoÖãã KÖEJHDEFG
 Úãã^Á[K&

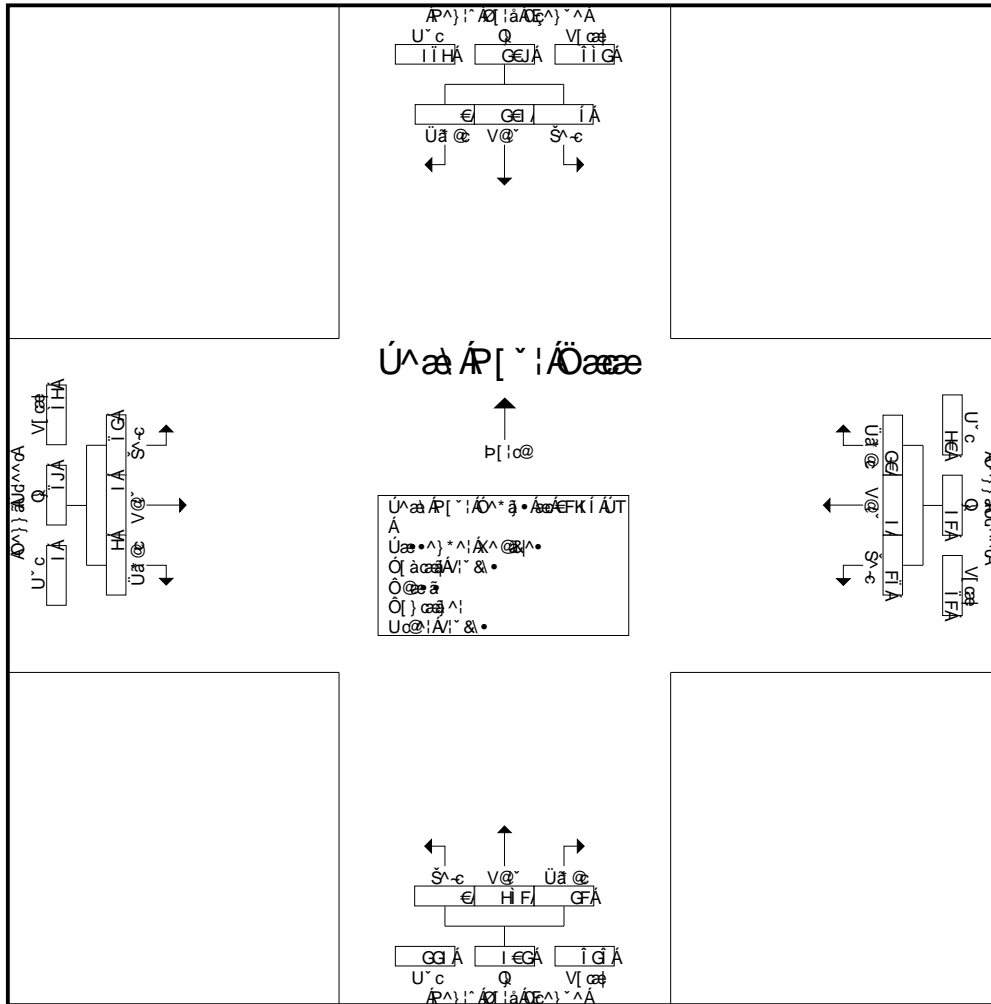

Úã ÁR[~|ÁÖããë * ÁÁQ[| ÁEKKÁÚT ÁEKKÁÚT ÁEKKÁÚT ÁEKKÁÚT ÁEKKÁÚT
 Úã ÁR[~|ÁÖããë * ÁÁQ[| ÁEKKÁÚT ÁEKKÁÚT ÁEKKÁÚT ÁEKKÁÚT ÁEKKÁÚT

	EKKÁÚT				EKKÁÚT				EKKÁÚT				EKKÁÚT			
ÉÉÁ á•È	2	H	€	H	7	F	F	J	€	JF	6	Ji	FH	1	€	FI
ÉFÁ á•È	F	ii	€	ii	H	2	i	FF	€	Ji	i	FEE	Fi	€	€	Fi
ÉHEÁ á•È	€	ii	€	ii	i	F	11	19	€	JH	i	Ji	25	€	H	28
ÉIÁ á•È	G	66	€	68	I	€	i	FF	€	101	i	107	Gh	F	4	G
V cãK[^ ^	i	GE	€	GEJ	GF	I	G	i€	€	H F	GF	I EG	ii	G	i	ii
Á ÁQ EÁV cã	GE	JiE	€	Á	IG	i	i€	Á	€	JiE	iEG	Á	iJiE	GH	i	Á
UPÖ	EÉG	EiH	EE€	Eii	Ei€	E€€	Eii	Eii	EE€	EiH	EiI	EiH	Ei€	E€€	EiH	Eii

Ó[~ } , o ÁM | ä , ä a Q & E
 UUÁO] c Á F F I
 Ó[! !] ä Ö Ö Á G I i
 Q I F D G I È É I

Óä Á - Á [] * Á ^ ä @
 Þ Æ U K P ^) ! ^ Á Q | ä Á Ö E ^) ^
 Ö E Y K Ö ^) } ä U d ^ ^ c
 Y ^ ä @ : K Á ^) } } ^

Ö Ä Á Þ ä ^ K Ö Ö P Ö Ö T Ö
 Ú ä Á Ö [ä ^ K E E E E E E F
 Ú ä ö Á Ö ä ^ K Ö Ö J H Ö E F G
 Ú ä ^ Á Þ K G

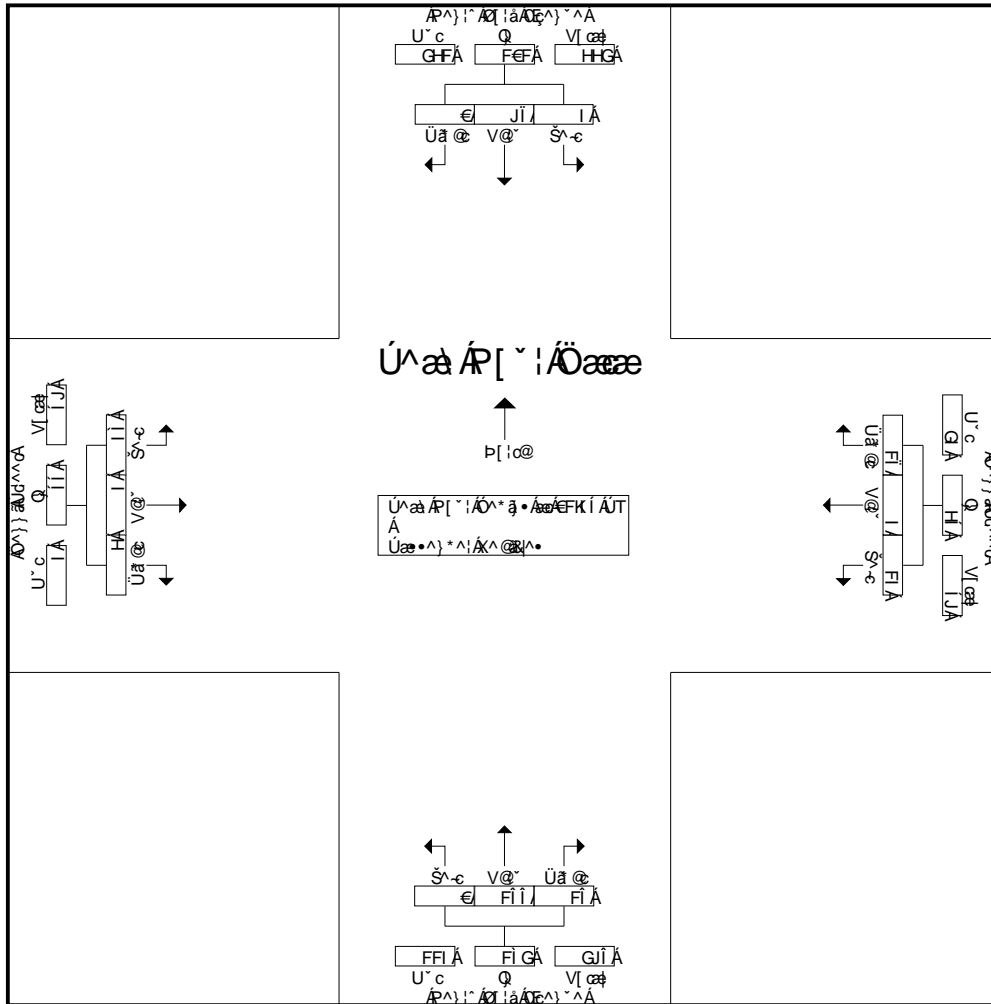

Útárár [~] Á Ö ä } * ä Á [[Á F K Í Á Ú Á Á Á G K K Á Ú Á Á Ú ä ä Á Á - Á
 Útárár [~] Á [Á Ö ä Ö Á] ! : ä @ Á ^ * ä Á K

	efkí ÁÚT				efkí ÁÚT				efkí ÁÚT				efkí ÁÚT			
ÉÉÁ ä ä È	2	Fí	€	FJ	€	€	G	G	€	IG	6	48	FF	3	€	FI
ÉFÍ Á ä È	€	30	€	30	í	F	€	í	€	H	I	IF	FF	F	€	FG
ÉHÉ Á ä È	€	GG	€	GG	G	2	í	F€	€	IF	I	Ií	F€	€	€	F€
ÉÍ Á ä È	G	G	€	H€	7	F	9	17	€	46	G	Ií	16	€	3	19
V [ö Á K] [^	I	Jí	€	F€F	FI	I	Fí	H	€	Fí	Fí	FI G	Ií	I	H	Ií
Á Á Ö] É V [ö	I	Jí	€	Á	I €	FFÈ	Ií È	Á	€	JFÈG	Ií È	Á	Ií ÈH	Ií ÈH	Ií È	Á
Ú Þ Ö	È €	È €	È €	È G	È €	È €	È G	È Fí	È €	È €	È Ií	È Ií	È Ií €	È H	È €	È G

Ö|~}•ÁV|ã ä^áQ&É
 UUÁÖ|çÁFíí
 Ö|í|}ãÉÖÖÁGíí
 QíFDGíÉGí

Öã: Á-Áí}•ÁÖã&@
 ÞÉUíP^}í: ÁQ|ãÁÖ^}^
 ÖEY KÁÖ^}ãUd^^c
 Y^ã&@:KÁU^}^

Öã^Pã ^ KÖÓP.ÖÖÖ Ö
 Úã^ÁÖ|ã KÉÉÉÉÉÉÉÉÉÉ
 Úã&Öã KÖÖJHDEFG
 Úã^ÁP| K&

Ö|í|}•ÁV|ã çãÉÖÖ ÁçãÁV|~&•

Úã&ÁV ã ^	P^}í: ÁQ ãÁÖ^}^ Uí~çã ~}ã				Ö^}ãUd^^c Y^•çã ~}ã				P^}í: ÁQ ãÁÖ^}^ P íçã ~}ã				Ö^}ãUd^^c Öãçã ~}ã				Q çãV çã
	Š^c	V@~	Uã @	ç ÉV çã	Š^c	V@~	Uã @	ç ÉV çã	Š^c	V@~	Uã @	ç ÉV çã	Š^c	V@~	Uã @	ç ÉV çã	
€FKÉÁÚT	€	í	€	í	€	F	€	F	€	F€	€	F€	G	€	€	G	Fí
€FKí ÁÚT	€	í	€	í	€	€	€	€	€	F€	€	F€	F	€	€	F	Fí
€FKÉÁÚT	€	í	€	í	€	€	€	€	€	Fí	€	Fí	F	€	€	F	GF
€FKí ÁÚT	€	í	€	í	€	€	€	€	€	FJ	€	FJ	G	€	€	G	Gí
V çã	€	GF	€	GF	€	F	€	F	€	íí	€	íí	í	€	€	í	íG
€GKÉÁÚT	€	í	€	í	F	€	€	F	€	HG	€	HG	F	€	€	F	í€
€GKí ÁÚT	€	í	€	í	€	€	€	€	€	GH	€	GH	í	€	€	í	Hí
€GKÉÁÚT	€	FG	€	FG	€	€	G	G	€	FH	€	FH	F	€	€	F	Gí
€GKí ÁÚT	€	í	F	í	€	€	€	€	€	í	€	í	F	€	€	F	Fí
V çã	€	HG	F	HH	F	€	G	H	€	íí	€	íí	í	€	€	í	FFJ
Ö ã: áÁV çã	€	íH	F	íí	F	F	G	í	€	FGJ	€	FGJ	FI	€	€	FI	GF
ç í: &ÖÁ	€	JíÉF	FÉ	Á	G	G	í€	Á	€	F€€	€	Á	F€€	€	€	Á	Á
V çãÁ	€	GíÉ	ÉÉ	GíÉ	ÉÉ	ÉÉ	F	G	€	ííÉ	€	ííÉ	í	€	€	í	

Úã&ÁV ã ^	P^}í: ÁQ ãÁÖ^}^ Uí~çã ~}ã				Ö^}ãUd^^c Y^•çã ~}ã				P^}í: ÁQ ãÁÖ^}^ P íçã ~}ã				Ö^}ãUd^^c Öãçã ~}ã				Q çãV çã
	Š^c	V@~	Uã @	ç ÉV çã	Š^c	V@~	Uã @	ç ÉV çã	Š^c	V@~	Uã @	ç ÉV çã	Š^c	V@~	Uã @	ç ÉV çã	
U^ã: ÁP í: ÁQ ã: áÁV çã • á ÁQ í: ÁFKí ÁÚT Áí ÉGKÉÁÚT ÁU^ã: ÁFÁ-ÁF																	
U^ã: ÁP í: ÁQ ã: áÁV çã • á ÁQ í: ÁFKí ÁÚT Áí ÉGKÉÁÚT ÁU^ã: ÁFÁ-ÁF																	
€FKí ÁÚT	€	í	€	í	€	€	€	€	€	FJ	€	FJ	G	€	€	G	Gí
€GKÉÁÚT	€	í	€	í	1	€	€	F	€	32	€	32	F	€	€	F	40
€GKí ÁÚT	€	í	€	í	€	€	€	€	€	GH	€	GH	5	€	€	5	Hí
€GKÉÁÚT	€	12	€	12	€	€	2	2	€	FH	€	FH	F	€	€	F	Gí
V çãÁV í: ^	€	HF	€	HF	F	€	G	H	€	íí	€	íí	J	€	€	J	FHE
Á ÁQ í: ÉV çã	€	F€€	€	Á	HÉH	€	ííÉ	Á	€	F€€	€	Á	F€€	€	€	Á	Á
UPØ	€€€	Éíí	€€€	Éíí	€€	€€€	€€	Éíí	€€€	Éíí	€€€	Éíí	€€	€€€	€€€	Éíí	Éíí

Ó[] , o ÁM | a , a a Q & E
 UU Á Q | c A F F I I
 Ó [|] } a a Ó Á G I i
 Q | F Á G I I È ð I

Ó a Á - Á [] * Á O a a @
 Þ ð U K P ^) ! ^ Á Q | a Á Q E ^) ^ ^
 Ö E Y K Á O ^) } a U d ^ ^ c
 Y ^ a a @ : K Á U " } } ^

Ö Þ ^ Á p a a ^ K S Ó Ó P . Ö Ö Ö T Ö
 Ú a ^ Á Q | a ^ K E E E E E E E F
 Ú a a o Á a a ^ K G E J H D E F G
 Ú a a ^ Á p [K G

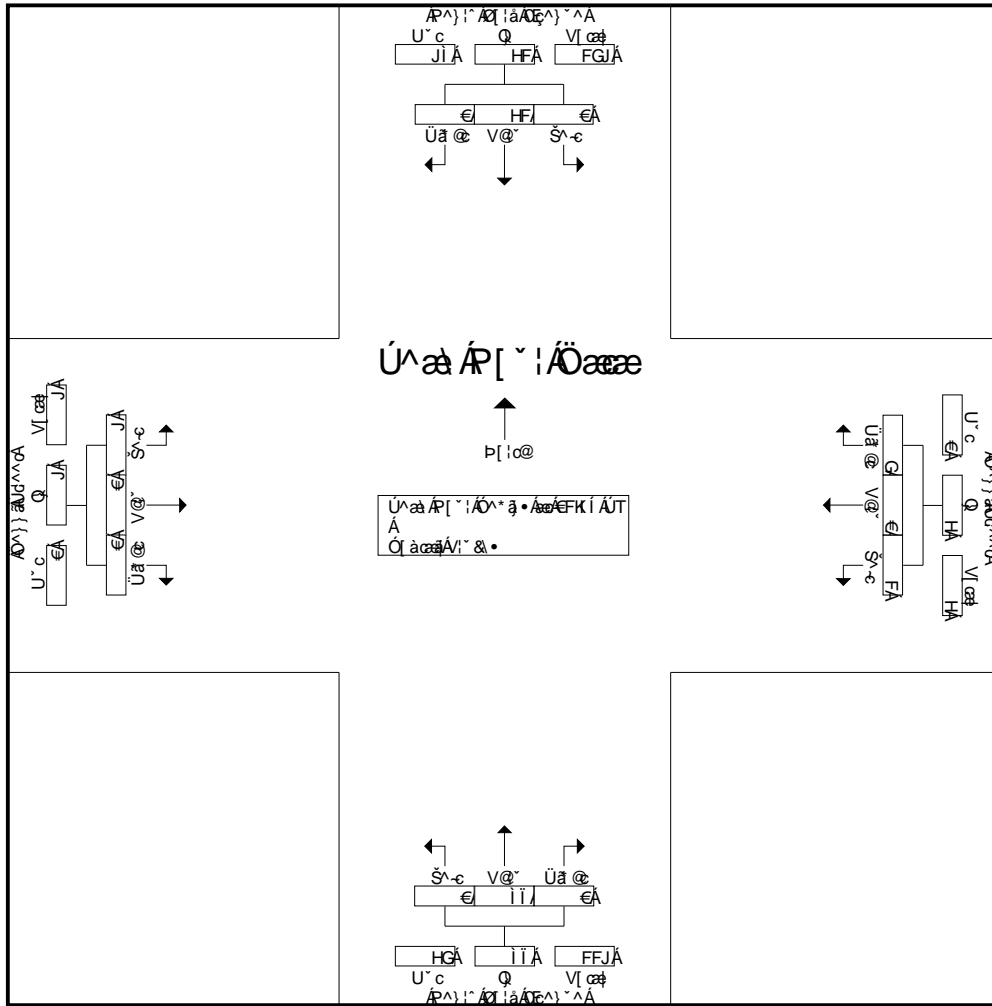

Ú^a a Á R [^ | Á Ö a a * a a Á [] { e F K I Á Ú T Á e G K E Á Ú T Á Ú ^ a a Á Á - Á
 Ú^a a Á R [^ | Á Ö a a Q [] | : a a O ^ ^ a a Á a K

	e F K I Á Ú T				e F K I Á Ú T				e F K I Á Ú T				e F K I Á Ú T			
É e Á a ^ È	€	î	€	î	€	€	€	€	€	FJ	€	FJ	G	€	€	G
É F I Á a ^ È	€	î	€	î	1	€	€	F	€	32	€	32	F	€	€	F
É H E Á a ^ È	€	î	€	î	€	€	€	€	€	GH	€	GH	5	€	€	5
É I I Á a ^ È	€	12	€	12	€	€	2	2	€	FH	€	FH	F	€	€	F
V œ K [] ^	€	HF	€	HF	F	€	G	H	€	I I	€	I I	J	€	€	J
Á Á Q Á V œ	€	F€€	€	Á	H H	€	I I È	Á	€	F€€	€	Á	F€€	€	€	Á
U P Ø	€€€€	È I	€€€€	È I	€€ €	€€€€	È I	È I	€€€€	È I	€	€€€€	È I	€€€€	€€€€	È I

Ö[~]oÁM|ããáÁQ&É
 UUÁÖcÁFIÍ
 Ö[~]ãÖÖcÁGÍÍ
 QIFDÖIÉGI

Öã Á-Á[~]*ÁÖã&@
 ÞEUKP^)^ ÁQ|ãÁÖ^)^ ^
 ÖEY KÁÖ^})ãUd^^c
 Y^ã&@:KÁU^})^

Öã Á-Á[~] KÖÖP.ÖÖT Ö
 Uã ÁÖ|ã KÖÖÖÖÖÖF
 UãöÁÖã KÖÖJÖÖFÖG
 Uã Á-Á[~] KÖ

Ö[~]•ÁUãcãÖÖã

UãöÁ-Á ^	P^)^ ÁQ ãÁÖ^)^ ^ UÍ^cã[~]ã				Ö^})ãUd^^c Y^•cã[~]ã				P^)^ ÁQ ãÁÖ^)^ ^ P[~]cã[~]ã				Ö^})ãUd^^c Öãcã[~]ã				QdÁV cã
	Š^c	V@~	Uã @	QJ ÉV cã	Š^c	V@~	Uã @	QJ ÉV cã	Š^c	V@~	Uã @	QJ ÉV cã	Š^c	V@~	Uã @	QJ ÉV cã	
€FK€ÁUT	€	G	€	G	€	€	€	€	€	F	€	F	€	€	€	€	H
€FKÍ ÁUT	€	G	€	G	€	€	€	€	€	I	€	I	€	€	€	€	I
€FK€ÁUT	€	€	€	€	€	€	€	€	€	F	€	F	F	€	€	€	G
€FKÍ ÁUT	€	€	€	€	€	€	€	€	€	F	€	F	€	€	€	€	F
V[cã	€	I	€	I	€	€	€	€	€	I	€	I	F	€	€	€	FG
€G€€ÁUT	€	I	€	I	€	€	€	€	€	I	€	I	€	€	€	€	FF
€GFI ÁUT	€	I	€	I	F	€	€	F	€	I	€	I	F	€	€	€	FÍ
€GK€ÁUT	€	F	€	F	€	€	€	€	€	F	€	F	€	€	€	€	G
€GKÍ ÁUT	€	G	€	G	€	€	€	€	€	F	€	F	€	€	€	€	H
V[cã	€	FI	€	FI	F	€	€	F	€	FI	€	FI	F	€	€	€	HF
Ö:ãã ÁÁV[cã	€	FI	€	FI	F	€	€	F	€	GG	€	GG	G	€	€	G	I H
QJ : & ÖÁ	€	F€€	€	Á	F€€	€	€	Á	€	F€€	€	Á	F€€	€	€	Á	Á
V[cãÁ	€	I F€	€	I F€	Q€H	€	€	Q€H	€	I F€G	€	I F€G	I È	€	€	I È	

UãöÁ-Á ^	P^)^ ÁQ ãÁÖ^)^ ^ UÍ^cã[~]ã				Ö^})ãUd^^c Y^•cã[~]ã				P^)^ ÁQ ãÁÖ^)^ ^ P[~]cã[~]ã				Ö^})ãUd^^c Öãcã[~]ã				QdÁV cã
	Š^c	V@~	Uã @	QJ ÉV cã	Š^c	V@~	Uã @	QJ ÉV cã	Š^c	V@~	Uã @	QJ ÉV cã	Š^c	V@~	Uã @	QJ ÉV cã	
U^ã ÁP[~] ÁÖ:ãã •ã ÁQ { Á€FKÍ ÁUT Á€GK€ÁUT ÁU^ã ÁFÁ-ÁF																	
U^ã ÁP[~] ÁF(ÁÖ) cã ÁQ c!^&ã } ÁÖ^ã •Áã€FKÍ ÁUT																	
€FKÍ ÁUT	€	€	€	€	€	€	€	€	€	F	€	F	€	€	€	€	F
€G€€ÁUT	€	I	€	I	€	€	€	€	€	7	€	7	€	€	€	€	FF
€GFI ÁUT	€	7	€	7	1	€	€	1	€	I	€	I	1	€	€	1	15
€GK€ÁUT	€	F	€	F	€	€	€	€	€	F	€	F	€	€	€	€	G
V[cãÁK[~] ^	€	FG	€	FG	F	€	€	F	€	FI	€	FI	F	€	€	F	GJ
Á ÁQ ÉV[cã	€	F€€	€	Á	F€€	€	€	Á	€	F€€	€	Á	F€€	€	€	Á	Á
UPØ	€€€€	È GJ	€€€€	È GJ	€G €	€€€€	€€€€	€G €	€€€€	È H	€€€€	È H	€G €	€€€€	€€€€	€G €	È I H

Ó[~}•ÁM|ãããQ&É
 UUÁQ|cÁFíí
 Ó[!:]ããÖÖÁGíí
 QíFÁGíÉí

Óã Á -Áí } * ÁÓãã@
 ÞÉUíKíP^ } !^ ÁQí |ãÁQÉ^ } ^
 ÖEY KÍÓ^ } } áUd^^c
 Y ^ãã@:KÁU } } ^

ÖE^ÁPãã ^ KÍÓÓP.ÖÖÓT Ö
 ÚãÁÖ[ãã KÍÉÉÉÉÉÉÉÉF
 ÚããóÖãã KÍGÉJíDEFG
 Úãã^ÁP[KÍG

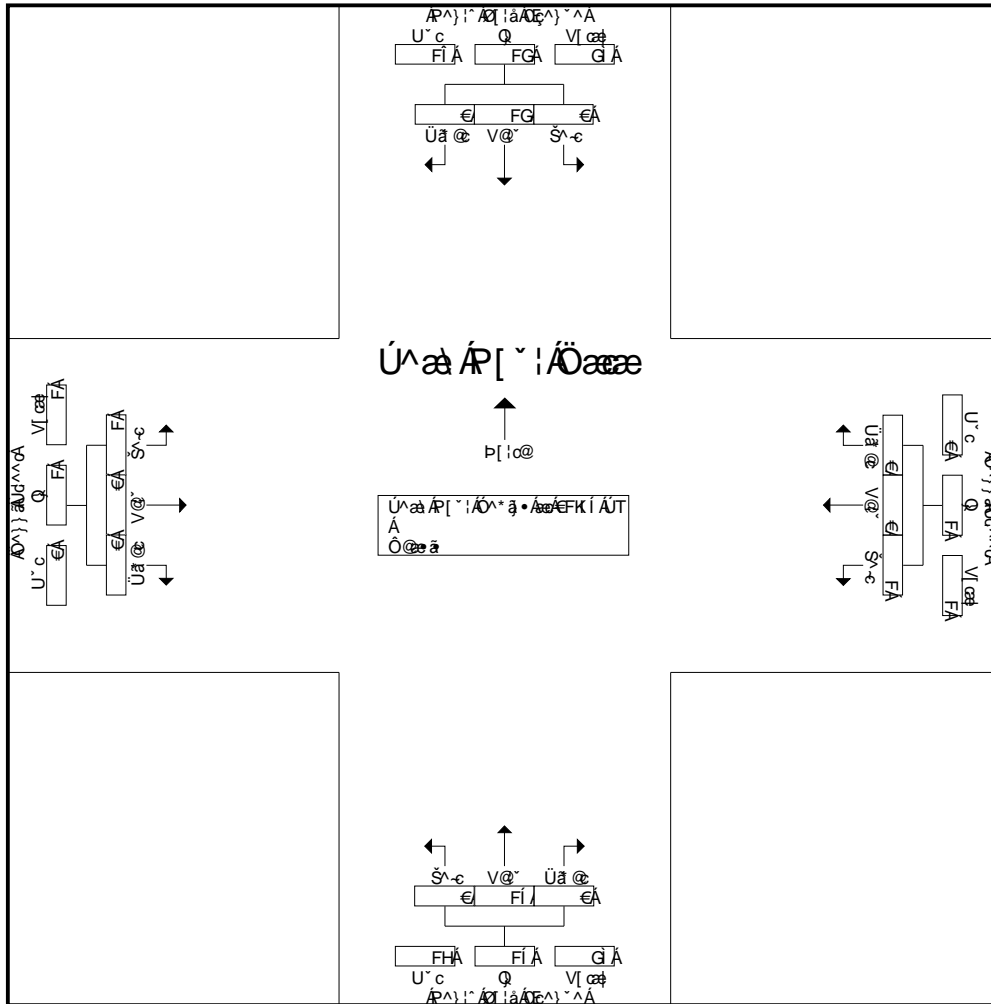

ÚããÁP[~!ÖÖããã ÁP[!ÖÖããã ÁP[!ÖÖããã ÁP[!ÖÖããã
 ÚããÁP[~!ÖÖããã ÁP[!ÖÖããã ÁP[!ÖÖããã ÁP[!ÖÖããã

	efkí ÁÚT				efkí ÁÚT				efkí ÁÚT				efkí ÁÚT			
ÉéÁ á•É	€	€	€	€	€	€	€	€	€	F	€	F	€	€	€	€
ÉFíÁ á•É	€	I	€	I	€	€	€	€	€	7	€	7	€	€	€	€
ÉHEÁ á•É	€	7	€	7	1	€	€	1	€	í	€	í	1	€	€	1
ÉíÁ á•É	€	F	€	F	€	€	€	€	€	F	€	F	€	€	€	€
V cãK[] { ^	€	FG	€	FG	F	€	€	F	€	Fí	€	Fí	F	€	€	F
Á ÁQí] V cã	€	F€€	€	Á	F€€	€	€	Á	€	F€€	€	Á	F€€	€	€	Á
UPÖ	€€€	€GJ	€€€	€GJ	€€€	€€€	€€€	€€€	€€€	€H	€€€	€H	€€€	€€€	€€€	€€€

Ö[~]oÁM|ãããÁQ&É
 UUÁÖcÁFIÍ
 Ö[~]ããÖÖãGíí
 QIFDííÉíí

Öã Á-Á[~]*ÁÖã&@
 ÞEUKP^)^ÁQ|ãÁÖ^)^^
 ÖEY KÁÖ^})ãUd^^c
 Y^ã&@:KÁU^})^

Öã Á-Á[~] K&ÓÓP.ÖÖÖT Ö
 Úã ÁÖ|ã K&E&E&E&E&E&E&E
 Úã&ÁÖã K&E&E&E&E&E&E&E
 Úã Á-Á[~] K&E

Ö[~]•ÁU|ãããÖ[~]ãã^

Úã&Á-Á[~]^	P^})ÁQ ãÁÖ^)^^ UÍ^cã[~]ã				Ö^})ãUd^^c Y^•cã[~]ã				P^})ÁQ ãÁÖ^)^^ P[~]cã[~]ã				Ö^})ãUd^^c Öãcã[~]ã				QdÁV cã
	Š^c	V@^	Úã@	Q ÉV cã	Š^c	V@^	Úã@	Q ÉV cã	Š^c	V@^	Úã@	Q ÉV cã	Š^c	V@^	Úã@	Q ÉV cã	
€FKÉÁÚT	€	FF	€	FF	€	€	€	€	€	FE	€	FE	H	€	€	H	G
€FKÍ ÁÚT	€	J	€	J	€	€	€	€	€	FE	€	FE	€	€	€	€	FJ
€FKÉÁÚT	€	FH	€	FH	€	€	€	€	€	GE	€	GE	F	€	€	F	H
€FKÍ ÁÚT	€	FE	€	FE	€	€	€	€	€	FI	€	FI	G	€	€	G	G
V cã	€	I H	€	I H	€	€	€	€	€	I I	€	I I	I	€	€	I	F&H
€GKÉÁÚT	€	i	€	i	€	€	€	€	€	FG	€	FG	€	€	€	€	GE
€GKÍ ÁÚT	€	FF	€	FF	€	€	€	€	€	FÍ	€	FÍ	€	€	€	€	G
€GKÉÁÚT	€	GH	€	GH	€	€	€	€	€	HH	€	HH	G	€	€	G	I I
€GKÍ ÁÚT	€	FG	€	FG	€	€	€	€	€	FF	€	FF	H	€	€	H	G
V cã	€	I I	€	I I	€	€	€	€	€	I H	€	I H	I	€	€	I	F&H
Ö[~]ã Á-Á[~] cã	€	Jí	€	Jí	€	€	€	€	€	F&í	€	F&í	FF	€	€	FF	GÍ
Q ÉV cã	€	F&E	€	Á	€	€	€	Á	€	F&E	€	Á	F&E	€	€	Á	Á
V cã	€	I F&H	€	I F&H	€	€	€	€	€	I I	€	I I	I É	€	€	I É	

Úã&Á-Á[~]^	P^})ÁQ ãÁÖ^)^^ UÍ^cã[~]ã				Ö^})ãUd^^c Y^•cã[~]ã				P^})ÁQ ãÁÖ^)^^ P[~]cã[~]ã				Ö^})ãUd^^c Öãcã[~]ã				QdÁV cã
	Š^c	V@^	Úã@	Q ÉV cã	Š^c	V@^	Úã@	Q ÉV cã	Š^c	V@^	Úã@	Q ÉV cã	Š^c	V@^	Úã@	Q ÉV cã	
Úã&Á-Á[~]^ Á-Á[~] cã • Á-Á[~] cã	€	FF	€	FF	€	€	€	€	€	FI	€	FI	2	€	€	2	G
Úã&Á-Á[~]^ Á-Á[~] cã • Á-Á[~] cã	€	i	€	i	€	€	€	€	€	FG	€	FG	€	€	€	€	GE
Úã&Á-Á[~]^ Á-Á[~] cã • Á-Á[~] cã	€	FF	€	FF	€	€	€	€	€	FÍ	€	FÍ	€	€	€	€	G
Úã&Á-Á[~]^ Á-Á[~] cã • Á-Á[~] cã	€	23	€	23	€	€	€	€	€	33	€	33	G	€	€	G	58
V cã	€	I G	€	I G	€	€	€	€	€	I I	€	I I	I	€	€	I	F&H
Á-Á[~] cã	€	F&E	€	Á	€	€	€	Á	€	F&E	€	Á	F&E	€	€	Á	Á
UPØ	€€€€	ÉÍÍ	€€€€	ÉÍÍ	€€€€	€€€€	€€€€	€€€€	€€€€	ÉÍÍ	€€€€	ÉÍÍ	É€€	€€€€	€€€€	É€€	ÉÍJ

Ó[~}•ÁM|ãããÁQ&É
 UUÁQ|cÁFFÍÍ
 Ó[!|}ããÓÖÁGÍÍ
 Q|FÁG|ÉÍÍ

Óã Á -Á[] * ÁÓãã@
 ÞÉUÍKÍP^)^!^ ÁQ |ãÁQÉ^)^^
 ÓEY KÍÓ^})ãUd^^c
 Y^ãã@:KÁU"}))^

ÓE^ÁPãã ^ KÍSÓÓP.ÓÖÓT Ö
 ÚãÁÁQ[ãã KÍEEEEEEEF
 ÚããóÓãã KÍGÍJHDEFG
 Úãã^ÁP[KÍG

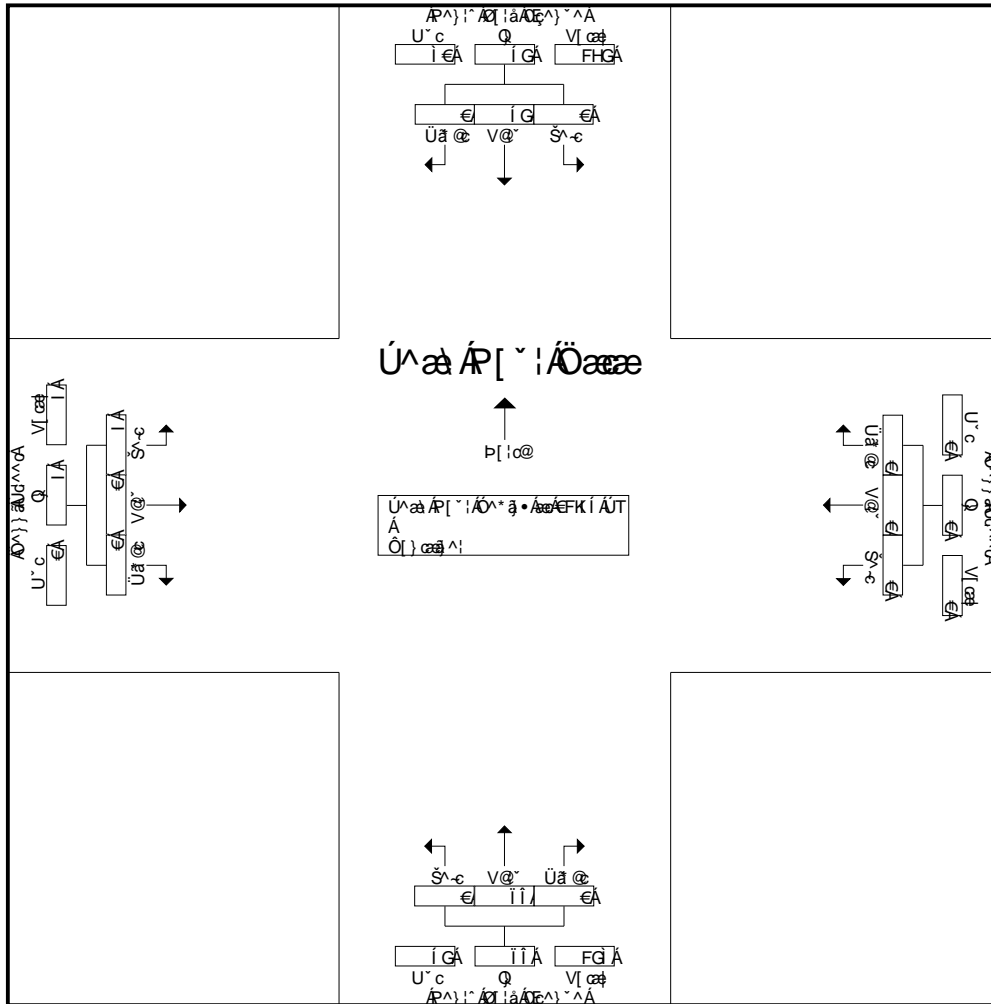

Úãã ÁP[~!ÁQãã •ã ÁQ[! ÁFKÍÁÚT Á ÁGKÁÚT ÁÚãã ÁÁ Á-Á
 Úãã ÁP[~!ÁQãã Óãã ÓQ[!|}ãã ÓÁ^ã •ÁãK

	efkí ÁÚT				efkí ÁÚT				efkí ÁÚT				efkí ÁÚT			
ÉÉÁ á•É	€	FE	€	FE	€	€	€	€	€	FI	€	FI	2	€	€	2
ÉFÍ Á á•É	€	i	€	i	€	€	€	€	€	FG	€	FG	€	€	€	€
ÉHEÁ á•É	€	FF	€	FF	€	€	€	€	€	Fí	€	Fí	€	€	€	€
ÉÍ Á á•É	€	23	€	23	€	€	€	€	€	33	€	33	G	€	€	G
V cããK[]{ ^	€	íG	€	íG	€	€	€	€	€	íí	€	íí	I	€	€	I
Á ÁQ[]V cãã	€	FEE	€	Á	€	€	€	€	€	FEE	€	Á	FEE	€	€	Á
UPÓ	€€€	€íí	€€€	€íí	€€€	€€€	€€€	€€€	€€€	€íí	€€€	€íí	€í€€	€€€	€€€	€í€€

Ö[~]•ÁM|ããÁQ&É
 UUÁÖcÁFIÍ
 Ö[~]ãÖÖãGíí
 QIFDÖíÉí

Öã Á-Á[~]*ÁÖã&@
 ÞEUKP^)^ ÁQ|ãÁÖ^)^ ^
 ÖEY KÁÖ^})ãUd^^c
 Y^ã&@:KÁU^})^

Öã Á-Á[~] KÖÖP.ÖÖT Ö
 Úã ÁÖ[ã] KÖÖÖÖÖÖF
 Úã ÖÁÖã KÖÖJDEFG
 Úã Á-Á[~] K&

Ö[~]•ÁUããÁUc@ÁM^&•

Úã ÖÁÁ^ ^	P^)^ ÁQ ãÁÖ^)^ ^ UÍ^cÖã[~]ã				Ö^})ãUd^^c Y^•cã[~]ã				P^)^ ÁQ ãÁÖ^)^ ^ P[~]cÖã[~]ã				Ö^})ãUd^^c Öãcã[~]ã				QdÁV[~]cã
	Š^c	V@^	Uã @	Ö[~]ÉV[~]cã	Š^c	V@^	Uã @	Ö[~]ÉV[~]cã	Š^c	V@^	Uã @	Ö[~]ÉV[~]cã	Š^c	V@^	Uã @	Ö[~]ÉV[~]cã	
€FKÉÁUT	€	I	€	I	€	€	F	F	€	í	G	í	H	F	€	I	FÍ
€FKÍ ÁUT	€	G	€	G	€	€	€	€	€	FF	F	FG	í	€	F	í	ÖE
€FKÉÁUT	G	I	€	í	F	€	€	F	€	í	F	J	F	€	€	F	FÍ
€FKÍ ÁUT	€	H	€	H	€	€	€	€	€	FÍ	€	FÍ	G	€	€	G	ÖE
V[~]cã	G	FH	€	FÍ	F	€	F	G	€	I€	I	II	FF	F	F	FH	íI
€GKÉÁUT	F	í	€	í	F	€	F	G	€	í	€	í	F	€	€	F	Fí
€GKÍ ÁUT	€	F	€	F	€	€	€	€	€	í	F	í	F	€	€	F	J
€GKÉÁUT	€	G	€	G	€	€	€	€	€	í	I	FG	í	€	€	í	ÖE
€GKÍ ÁUT	€	F	€	F	€	€	F	F	€	I	€	I	G	€	F	H	J
V[~]cã	F	F€	€	FF	F	€	G	H	€	G	í	HF	F€	€	F	FF	íI
Ö[~]ã ÁÁ[~]cã	H	GH	€	Gí	G	€	H	í	€	íí	J	íí	GF	F	G	G	FHE
Ö[~]í:&ÖÁ	FFÉ	ííÉ	€	Á	I€	€	í€	Á	€	íí	FG	Á	ííÉ	IÉ	íÉH	Á	Á
V[~]cãÁ	GH	FíÉ	€	ÖE	FÉ	€	GH	HÉ	€	íÉ	íÉ	ííÉ	FíÉ	ÉÉ	FÉ	FíÉ	

Úã ÖÁÁ^ ^	P^)^ ÁQ ãÁÖ^)^ ^ UÍ^cÖã[~]ã				Ö^})ãUd^^c Y^•cã[~]ã				P^)^ ÁQ ãÁÖ^)^ ^ P[~]cÖã[~]ã				Ö^})ãUd^^c Öãcã[~]ã				QdÁV[~]cã
	Š^c	V@^	Uã @	Ö[~]ÉV[~]cã	Š^c	V@^	Uã @	Ö[~]ÉV[~]cã	Š^c	V@^	Uã @	Ö[~]ÉV[~]cã	Š^c	V@^	Uã @	Ö[~]ÉV[~]cã	
Úã ÁP[~] ÁÖ[~]ãã •ã ÁÖ[~] ÁFKÍ ÁUT Á EGKÉÁUT ÁUã ÁÁ-Á																	
Úã ÁP[~] ÁÁ[~]cã ÁÁ[~]cã •^&ã } ÁÖ^ã •Áã ÁFKÍ ÁUT																	
€FKÍ ÁUT	€	H	€	H	€	€	€	€	€	15	€	15	G	€	€	G	20
€GKÉÁUT	1	6	€	7	1	€	1	2	€	í	€	í	F	€	€	F	Fí
€GKÍ ÁUT	€	F	€	F	€	€	€	€	€	í	F	í	F	€	€	F	J
€GKÉÁUT	€	G	€	G	€	€	€	€	€	í	4	FG	6	€	€	6	ÖE
V[~]cãÁ[~]í^ ^	F	FG	€	FH	F	€	F	G	€	H	í	IG	F€	€	€	F€	íI
Á ÁÖ[~] ÉV[~]cã	íÉ	JGH	€	Á	í€	€	í€	Á	€	ííÉ	FFÉ	Á	F€€	€	€	Á	Á
UPØ	É€	É€€	É€€	ÉíI	É€	É€€	É€	É€	É€€	ÉFí	ÉFH	É€€	ÉFí	É€€	É€€	ÉFí	ÉH

Ó[~}•ÁM|ãããÁQ&E
 UUÁO|cÁFIÍ
 Ó[~}ãããÁQ&E
 QI FDI Ì È Ì

Óã Á -Á[~}•ÁOãã@
 ÞEUIKÁ^|~ÁQ|ãÁQ^~^
 ÖY KÁO^}ãUd^^c
 Y^ãã@:KÁ^}~^

ÖY Áã ^ K&ÓOP.ÖÖÖUT
 Uã ÁO|ãã K&E&E&E&E&E
 UããOãã K&E&E&E&E&E
 Uãã^Á[K&E

Ó[~}•ÁU|ãããÁUã•^}*^|K^@B^•ÁQ|ããÁV|~&•ÁQ|ãããÁQ|ããÁV|~&•

UããOÁVã ^	P^} ~ÁQ ãÁQ^~^ U ~cã[~}ã				Ö^} ãUd^^c Y^•cã[~}ã				P^} ~ÁQ ãÁQ^~^ P :cã[~}ã				Ö^} ãUd^^c Öããcã[~}ã				QãV cã
	Š~c	V@~	Uã@	Q ÈV cã	Š~c	V@~	Uã@	Q ÈV cã	Š~c	V@~	Uã@	Q ÈV cã	Š~c	V@~	Uã@	Q ÈV cã	
è K&EÁUT	í	íH	€	íí	í	F	í	FH	€	FGF	í	FG	G	F	F	G	GÍ
è KÍ ÁUT	G	íH	€	íí	í	F	J	FÍ	€	FFI	H	FFÍ	GF	G	€	GH	GF€
è K&EÁUT	F	IJ	€	í€	í	€	í	F€	€	FHH	I	FHÍ	FI	€	€	FI	GF
è KÍ ÁUT	G	íG	€	íí	í	G	H	F€	€	FG	I	FGJ	FÍ	G	F	GF	GÍ
V cã	F€	GÍ	€	GÍ	GF	I	GH	íí	€	IJH	FÍ	í€J	íJ	í	G	íí	JO€
è K&EÁUT	í	íí	€	í€	J	í	FF	G	€	FFH	í	FFÍ	FJ	€	€	FJ	G G
è KÍ ÁUT	G	íH	€	íí	F	€	í	í	€	íG	H	íí	GF	€	€	GF	Fíí
è K&EÁUT	í	íí	€	íH	F€	G	F€	GG	€	íí	í	JG	J	€	F	F€	Fíí
è KÍ ÁUT	F	íí	€	íí	I	€	I	í	€	íí	€	íí	F€	€	€	F€	FFJ
V cã	FI	GF	€	GÍ	G	í	HF	íG	€	HÍ	FH	HJ	íJ	€	F	í€	íG
Ö:ããÁV cã	G	íè	€	íHG	íí	FF	íí	FF€	€	íGJ	GJ	ííí	FH	í	H	Fíí	Fííí
Q :ããÁ	IÈ	JíÈ	€	Á	IÈ	F€	IJÈ	Á	€	JíÈ	HÈ	Á	JíÈ	HÈ	GÈ	Á	Á
V cãÁ	FÈ	HÈ	€	HGÈ	GÈ	ÈÈ	HÈ	íÈ	€	íÈÈ	FÈ	íGÈ	íÈ	ÈÈ	ÈÈ	íÈ	Á
Uã•^}*^ K^@B^•ÁQ ããÁV ~&•	GF	GÍF	€	G G	HJ	í	H	IJ	€	íFF	G€	íHF	F€	I	H	FFF	FF€H
Á Áã•^}*^ K^@B^•ÁQ ããÁV ~&•	ííÈ	íFÈ	€	íH	ííÈ	íHÈ	íFÈ	íFÈ	€	íHÈ	íJ	íHÈ	ííÈ	í€	F€€	íí	íí
Ó ããÁV ~&•	F	JF	€	JG	€	€	G	G	€	F€	€	F€	F€	€	€	F€	GF
Á ÁããÁV ~&•	IÈG	FíÈ	€	FíÈH	€	€	HÈ	FÈ	€	FGÈ	€	FGÈ	íÈG	€	€	íÈ	FGÈ
Ö@ãã	€	F€	€	F€	G	€	€	G	€	FG	€	FG	G	€	€	G	G
Á ÁO@ãã	€	G	€	FÈ	IÈ	€	€	FÈ	€	FÈ	€	FÈ	FÈ	€	€	FÈ	FÈ
Ó cãÁV ~&•	€	FHH	€	FHH	F	€	€	F	€	íG	€	íG	Fí	€	€	Fí	GH
Á ÁO cãÁV ~&•	€	GíÈG	€	G	GÈG	€	€	ÈÈ	€	JÈ	€	JÈ	FH	€	€	FGÈH	FíÈG
Uc@:ÁV ~&•	G	FH	€	Fí	H	I	FJ	G	€	Fí	J	G	I	F	€	í	íG
Á ÁUc@:ÁV ~&•	íÈH	GÈ	€	GÈ	íÈ	HíÈ	HíÈG	GÈÈ	€	GÈ	HF	H	GÈ	G€	€	HÈ	íÈ

UããOÁVã ^	P^} ~ÁQ ãÁQ^~^ U ~cã[~}ã				Ö^} ãUd^^c Y^•cã[~}ã				P^} ~ÁQ ãÁQ^~^ P :cã[~}ã				Ö^} ãUd^^c Öããcã[~}ã				QãV cã
	Š~c	V@~	Uã@	Q ÈV cã	Š~c	V@~	Uã@	Q ÈV cã	Š~c	V@~	Uã@	Q ÈV cã	Š~c	V@~	Uã@	Q ÈV cã	
UããÁV ~&•	5	83	€	88	6	F	í	FH	€	FGF	5	FG	26	F	1	28	255
è K&EÁUT	G	íH	€	íí	í	F	9	15	€	FFI	H	FFÍ	GF	2	€	GH	GF€
è KÍ ÁUT	F	IJ	€	í€	í	€	í	F€	€	133	I	137	FI	€	€	FI	GF
è K&EÁUT	G	íG	€	íí	í	2	H	F€	€	FG	I	FGJ	FÍ	G	F	GF	GÍ
V cãÁV ~&•	F€	GÍ	€	GÍ	GF	I	GH	íí	€	IJH	FÍ	í€J	íJ	í	G	íí	JO€
Á ÁU cãÁV ~&•	HÈ	JíÈ	€	Á	IÈÈ	íÈÈ	ííÈ	Á	€	JíÈ	HÈ	Á	JFÈ	íÈ	GÈH	Á	Á
UPØ	ÈÈ€	ÈÈ	ÈÈ€€	ÈÈí	ÈÈí	ÈÈ€€	ÈÈHU	ÈÈ€€	ÈÈ€€	ÈG	ÈÈ€€	ÈGJ	ÈÈí€	ÈÈG	ÈÈ€€	ÈÈí	ÈÈ€G

Ó[~}•ÁM|ãããÁ&É
 UUÁQ|cÁFíí
 Ó[!|}ããÁÁGíí
 Q|FÁGííÉíí

Óã Á -Áí } *Á^ãã@
 ÞÉUÍKÁ^}!^ ÁQ |ãÁÉ^}^
 ÓEY KÁÓ^} }ãUd^^c
 Y^ãã@:KÁ^}}^

ØÁ^Áã^ ^ KÓÓP.ØØÚT
 Úã^ÁQ|ã^ KÉÉÉÉÉÉF
 Úãã^Óãã^ KÁGJHBEFG
 Úãã^ÁP[KÁG

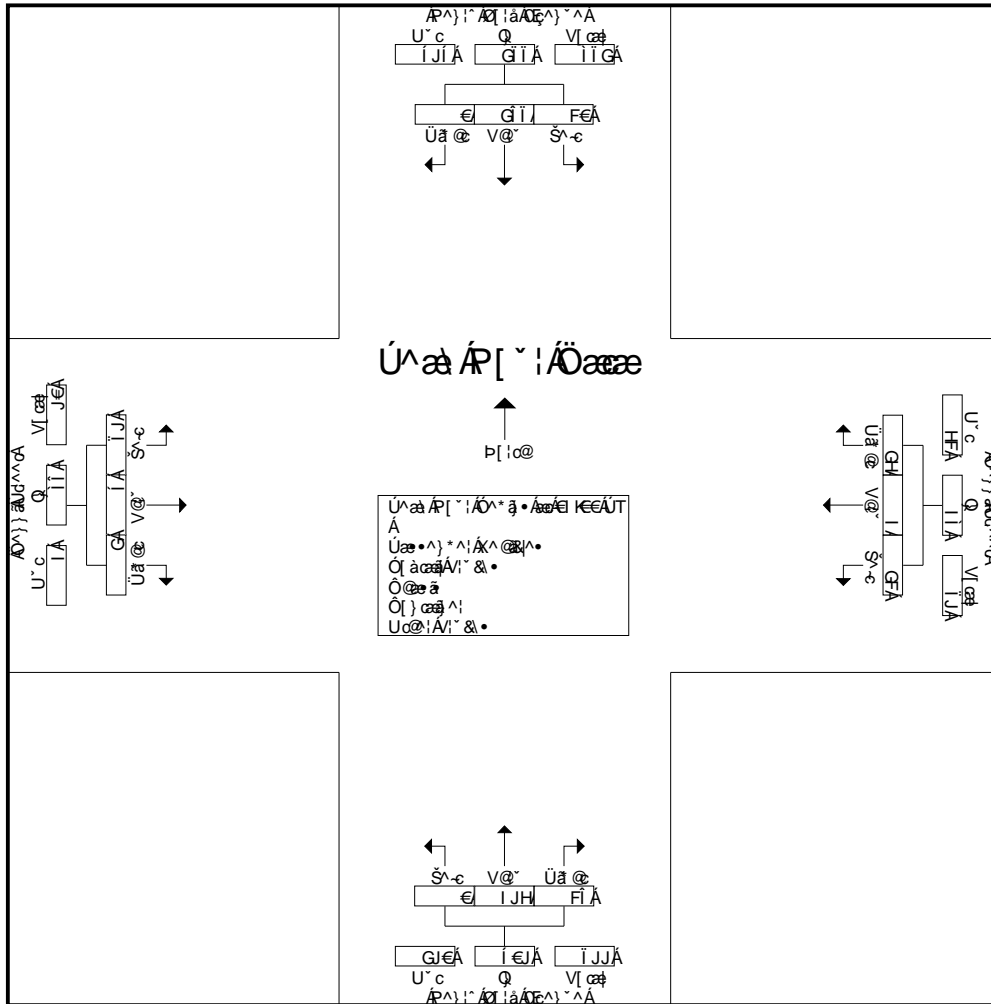

Úãã ÁP[~!Öããë } *Á^ãã@ { Áí KÉÚT Áí Áí KÍ ÁÚT Áí Úãã ÁP[~!Öããë } *Á^ãã@
 Úãã ÁP[~!Áí Öãã@Q|!|}ãã@Á^ããK

	e k í Á Ú T		e k í Á Ú T		e k í Á Ú T		e k í Á Ú T		e k í Á Ú T		e k í Á Ú T		e k í Á Ú T
ÉÉÁ á•É	G 82	€ 84	Í G H F€	€ FGF 5 FG	26	F 1	28						
ÉFÍ Á á•É	í íí	€ í€	J 5 11 25	€ FFI H FFí	GF	2	€ GH						
ÉHÉ Á á•É	G íH	€ íí	F € í í	€ 133 I 137	FI	€	€ FI						
ÉÍ Á á•É	6 íí	€ íH	10 G F€ GG	€ FG I FGJ	Fí	G	F GF						
V cãK {^	Fí Gí	€ GJG	Q J HÉ íí	€ IJH Fí í€J	íJ	í	G íí						
Á ÁQ ÉV cã	íÉ JIÉ	€ Á	HUÉ FIÉ IíÉ Á	€ JíÉ HÉ Á	JFÉ	íÉ	GH Á						
ÚPØ	ÉÉG ÉÉí	ÉÉ€ ÉÉJ	ÉÉG ÉÉí€ ÉÉG ÉÉí€	ÉÉ€ ÉÉG ÉÉ€ ÉÉG	ÉÉ€ ÉÉG	ÉÉ€ ÉÉG	ÉÉ€ ÉÉí						

Ö|~}•ÁV|ããÁQ&E
 UUÁQcAFI
 Ö|{ }ãÖÖãGii
 QIFDGiEgi

Öã Á-Á| }*Á^ãã@
 ÞEUIK^ } ÁQ|ãÁQ^ } ^
 ÖEY KÖ } }ãUd^^c
 Y^ãã@:KÜ } } ^

ÖE^ Áã ^ KÖÖP.ÖÖÜT
 Üã ÁQ|ã^ KÖÖÖÖÖF
 ÜããÖã^ KÖÖJÖEFG
 Üã^ ÁQ| KÖ

Ö|{ }•ÁV|ããÁQ&E}*Á^ãã@

ÜããÁQ ã^	P^ } ÁQ ãÁQ^ } ^ U ~cã } á				Ö } }ãUd^^c Y^•cã } á				P^ } ÁQ ãÁQ^ } ^ P {cã } á				Ö } }ãUd^^c Öãcã } á				QdãV cã
	Š^c	V@~	Uã@	Q ãV cã	Š^c	V@~	Uã@	Q ãV cã	Š^c	V@~	Uã@	Q ãV cã	Š^c	V@~	Uã@	Q ãV cã	
ei KEEÁUT	G	H	€	I€	í	F	I	FF	€	íí	H	íí	ÖE	F	F	GG	FIF
ei KIÁUT	G	GJ	€	HF	í	F	I	F€	€	íí	G	íí	FG	G	€	FI	FHF
ei KKEÁUT	F	G	€	G	I	€	H	í	€	Jí	H	F€€	í	€	€	í	FIG
ei KIÁUT	G	IF	€	IH	I	F	G	í	€	F€	I	F€	FI	F	F	Fí	FíI
V cã	í	FH	€	FIG	FJ	H	FH	Hí	€	H€	FG	HíG	íH	I	G	íJ	ííí
ei KEEÁUT	í	HU	€	II	ì	G	í	Fí	€	Jì	í	F€H	Fí	€	€	Fí	Fí€
ei KIÁUT	G	H	€	I€	F	€	H	I	€	íí	G	íí	FJ	€	€	FJ	FHF
ei KKEÁUT	í	G	€	H	J	G	ì	FJ	€	íJ	F	í€	í	€	F	í	FH€
ei KIÁUT	F	G	€	GG	G	€	H	í	€	H	€	H	J	€	€	J	íí
V cã	FI	FG	€	FI€	ÖE	I	ÖE	II	€	GíF	í	GíJ	íF	€	F	íG	íFí
Ö ããÁQ cã	GF	GíF	€	GíG	HU	í	HH	íJ	€	íFF	ÖE	íHF	F€	I	H	FFF	FF€H
Q { }&Ö	íE	JG€	€	Á	íJ€	íE	íF€	Á	€	JíE	H€	íE	JH€	H€	G€	Á	Á
V cã	F€	CH€	€	GíE	H€	€	H	íE	€	ííE	F€	ííE	J€	€	€	F€F	

ÜããÁQ ã^	P^ } ÁQ ãÁQ^ } ^ U ~cã } á				Ö } }ãUd^^c Y^•cã } á				P^ } ÁQ ãÁQ^ } ^ P {cã } á				Ö } }ãUd^^c Öãcã } á				QdãV cã
	Š^c	V@~	Uã@	Q ãV cã	Š^c	V@~	Uã@	Q ãV cã	Š^c	V@~	Uã@	Q ãV cã	Š^c	V@~	Uã@	Q ãV cã	
UããÁQ ã^	Š^c	V@~	Uã@	Q ãV cã	Š^c	V@~	Uã@	Q ãV cã	Š^c	V@~	Uã@	Q ãV cã	Š^c	V@~	Uã@	Q ãV cã	QdãV cã
UããÁQ ã^	Š^c	V@~	Uã@	Q ãV cã	Š^c	V@~	Uã@	Q ãV cã	Š^c	V@~	Uã@	Q ãV cã	Š^c	V@~	Uã@	Q ãV cã	QdãV cã
ei KEEÁUT	2	H	€	I€	6	1	4	11	€	íí	H	íí	20	F	1	22	FIF
ei KIÁUT	G	GJ	€	HF	í	F	I	F€	€	íí	G	íí	FG	2	€	FI	FHF
ei KKEÁUT	F	G	€	G	I	€	H	í	€	Jí	H	F€€	í	€	€	í	FIG
ei KIÁUT	G	41	€	43	I	F	G	í	€	104	4	108	FI	F	F	Fí	174
V cã	í	FH	€	FIG	FJ	H	FH	Hí	€	H€	FG	HíG	íH	I	G	íJ	ííí
ÁÁQ ãV cã	íE	JíE	€	Á	ííE	íE	HíE	Á	€	JíE	H€	íE	íJ€	íE	H€	Á	Á
UPØ	€íí	€GH	€€€	€G	€JG	€í€	€FH	€Jí	€€€	€Fí	€í€	€Fí	€íH	€€€	€€€	€í€	€íí

Ó[~}•ÁM|ãããÁQ&E
 UUÁQ|cÁFII
 Ó[!|}ãããÁGII
 Q|FÁG|E|G|

Óã Á -Á[] * Á^ãã@
 ÞEUIK^)^!^ ÁQ |ãÁE^)^^
 ÖEY KÁO^})ãUd^^c
 Y^ãã@:KÁU^})^

ÖE^ Áãã ^ KÓÓP.ÖÖÖÚT
 Úã ÁÖ[á^ KEEEEEEF
 Úãã ÁÖãã KGGJDEFG
 Úãã ÁÁ[K&

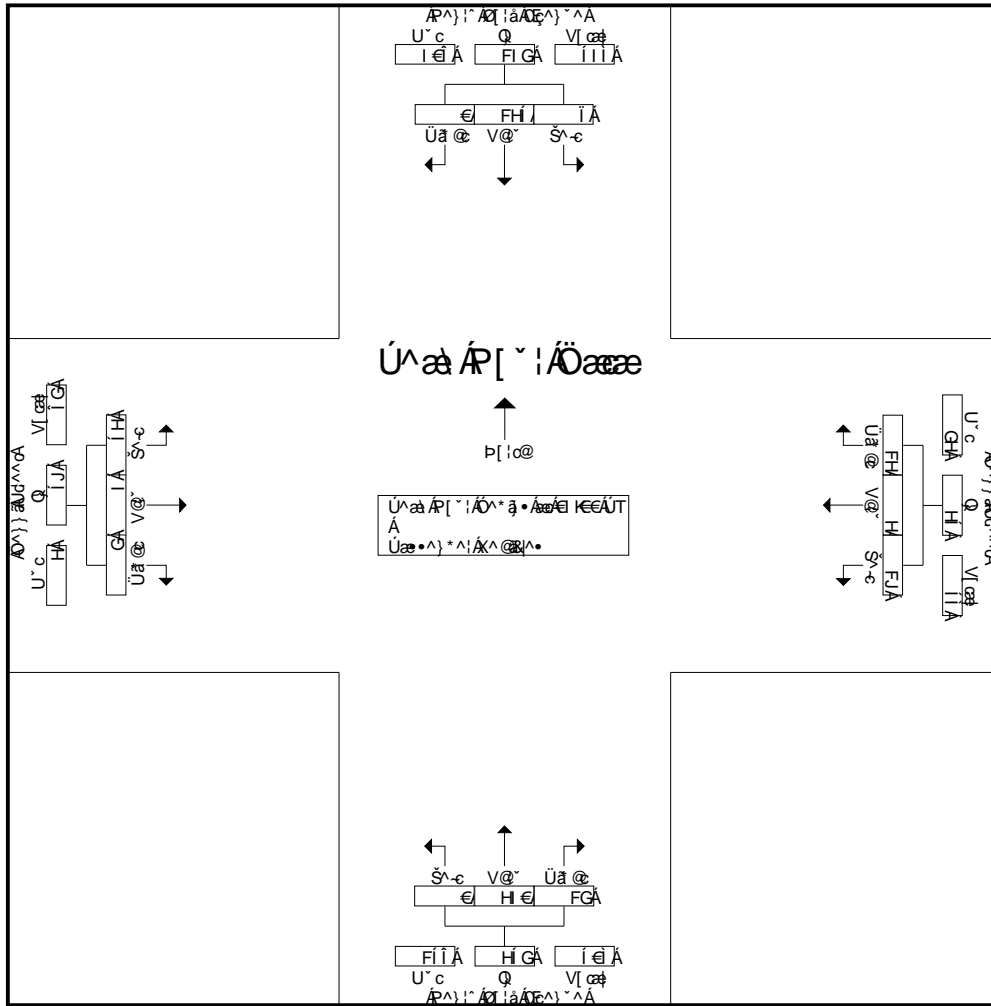

Úãã ÁR[~!Öããã •ã ÁQ[! ÁE KEEÚT ÁE ÁE KÍ ÁÚT ÁE Úãã ÁÁ Á-Á
 Úãã ÁR[~!Á[!ÖãããQ[!|!|ãã@Á^ã •ÁãK

	ei keeÚT				ei keeÚT				ei keeÚT				ei keeÚT			
ÉÉÁ á•È	2	H	€	I€	6	1	4	11	€	íí	H	íí	20	F	1	22
ÉFÍ Á á•È	G	GJ	€	HF	í	F	I	F€	€	íí	G	íí	FG	2	€	Fí
ÉHEÁ á•È	F	G	€	G	I	€	H	í	€	Jí	H	F€€	í	€	€	í
ÉÍ Á á•È	G	41	€	43	I	F	G	í	€	104	4	108	Fí	F	F	Fí
V[çãK[]{ ^	í	FH	€	FIG	FJ	H	FH	H	€	H€	FG	HG	íH	I	G	íJ
Á ÁQ[]E V[çã	I E	Jí E	€	Á	íí E	í E	Hí E	Á	€	Jí E	H E	Á	íJ E	í E	H E	Á
UPØ	Eíí	E GH	E€€	E G	E JG	Eí€	E FH	E Jí	E€€	E Fí	Eí€	E Fí	EíH	E€€	E€€	Eí€

Ó[·]·ÁM [ãã]Á&É
UUA[·]·ÁFI
Ó[·]·ÁFI
QIFÁIÉÍ

Óá Á -Á[·]·Á^ã@
BËU[KP^]·ÁQ [ãÁÉ^]·^
OEY KÁO^}áUd^^c
Y^ã@:KÁ"}^

Ø^Ápã ^ K5ÓOP.ØØÓÚT
Úá^ÁO [ã^ KEEEEEEF
Úcã^Oá^ KRGJHBEFG
Úã^Áp[K&

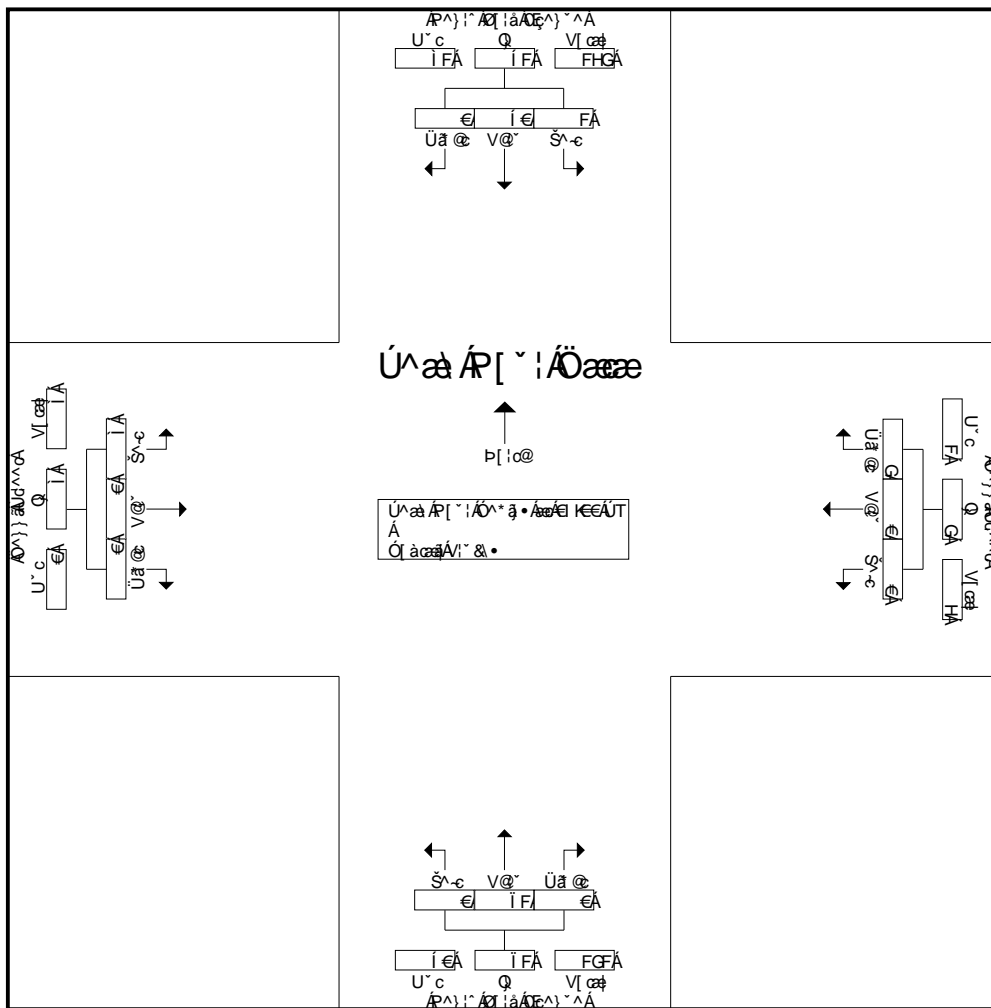

ÚááÁR[·]·ÁÖáæ·ÁÁ[·]·ÁI KEEÁÚT ÁI KÍÁÚT ÁUááÁÁ-Á
ÚááÁR[·]·ÁI [Óáæ]Ó[·]·ÁÁ[·]·Á

ÉÉÁ á·È	1	FI	€	FÍ	€	€	€	€	€	GF	€	GF	3	€	€	3
ÉFÍ Á á·È	€	í	€	í	€	€	2	2	€	22	€	22	F	€	€	F
ÉHEÁ á·È	€	F€	€	F€	€	€	€	€	€	FJ	€	FJ	H	€	€	H
ÉÍÁ á·È	€	21	€	21	€	€	€	€	€	J	€	J	F	€	€	F
V[·]·K[·]·{^	F	í€	€	ÍF	€	€	G	G	€	ÍF	€	ÍF	í	€	€	í
Á Á[·]·V[·]·	G	Jí	€	Á	€	€	F€€	Á	€	F€€	€	F€€	F€€	€	€	Á
UPØ	ÉI €	È Jí	È€€€	È Éí	È€€€	È€€€	ÈI €	ÈI €	È€€€	È È Éí	È€€€	È È Éí	È È í	È€€€	È€€€	È È í

Ò[~}oÁM|ã à^áQ&É
 UUÁÖ|çÁFIÍ
 Ö|{;}ãÖÖçãGíí
 Q|FDG|ÈG|

Öã: Á-Á[~} *ÁÖã&@
 ÞÉU|K|P^} í: ÁQ|ãÁÖE^} ^
 ÖEY|K|Ö^} } áUd^^c
 Y^ã&@|KÁU|} } ^

ÖE^Á|Þã ^ KÖÓOP.ÖÖÖUT
 Úã^ÁÖ|ã^ KÉÉÉÉÉÉÉÉÉÉ
 Úã&Öã^ KÖÖJ|B|E|F|G
 Úã^Á| K

Ö|{~} • ÁU|ã çãÖÖçã

Úã&ÖÁ ã ^	P^} í: ÁQ ãÁÖE^} ^ Úí~çã ~} á				Ö^} } áUd^^c Y^•çã ~} á				P^} í: ÁQ ãÁÖE^} ^ P {çã ~} á				Ö^} } áUd^^c Öãçã ~} á				Q çÁV çã	
	Š^ç	V@~	Úã@	ç ÉV çã	Š^ç	V@~	Úã@	ç ÉV çã	Š^ç	V@~	Úã@	ç ÉV çã	Š^ç	V@~	Úã@	ç ÉV çã		
É KÉÁÚT	€	F	€	F	€	€	€	€	€	Í	€	Í	€	€	€	€	€	Í
É KÍÁÚT	€	G	€	G	€	€	€	€	€	H	€	H	€	€	€	€	€	Í
É KÉÁÚT	€	G	€	G	F	€	€	F	€	G	€	G	F	€	€	€	€	Í
É KÍÁÚT	€	€	€	€	€	€	€	€	€	F	€	F	€	€	€	€	€	F
V çã	€	Í	€	Í	F	€	€	F	€	FF	€	FF	F	€	€	€	€	F
É KÉÁÚT	€	€	€	€	F	€	€	F	€	F	€	F	€	€	€	€	€	G
É KÍÁÚT	€	G	€	G	€	€	€	€	€	€	€	€	F	€	€	€	€	H
É KÉÁÚT	€	G	€	G	€	€	€	€	€	€	€	€	€	€	€	€	€	G
É KÍÁÚT	€	F	€	F	€	€	€	€	€	€	€	€	€	€	€	€	€	F
V çã	€	Í	€	Í	F	€	€	F	€	F	€	F	F	€	€	€	€	Í
Ö ã: áÁV çã	€	F€	€	F€	G	€	€	G	€	FG	€	FG	G	€	€	€	G	G
ç {;}&çã	€	F€€	€	Á	F€€	€	€	Á	€	F€€	€	Á	F€€	€	€	€	Á	Á
V çã	€	H È	€	H È	íÈ	€	€	íÈ	€	íÈ	€	íÈ	íÈ	€	€	€	íÈ	

Úã&ÖÁ ã ^	P^} í: ÁQ ãÁÖE^} ^ Úí~çã ~} á				Ö^} } áUd^^c Y^•çã ~} á				P^} í: ÁQ ãÁÖE^} ^ P {çã ~} á				Ö^} } áUd^^c Öãçã ~} á				Q çÁV çã	
	Š^ç	V@~	Úã@	ç ÉV çã	Š^ç	V@~	Úã@	ç ÉV çã	Š^ç	V@~	Úã@	ç ÉV çã	Š^ç	V@~	Úã@	ç ÉV çã		
Ú^ã&Á ~} í: ÁQ ã	€	€	€	€	€	€	€	€	€	€	€	€	€	€	€	€	€	€
Ú^ã&Á ~} í: ÁQ ã	€	€	€	€	€	€	€	€	€	€	€	€	€	€	€	€	€	€
É KÉÁÚT	€	F	€	F	€	€	€	€	€	5	€	5	€	€	€	€	€	6
É KÍÁÚT	€	2	€	2	€	€	€	€	€	H	€	H	€	€	€	€	€	Í
É KÉÁÚT	€	G	€	G	1	€	€	1	€	G	€	G	1	€	€	€	€	Í
É KÍÁÚT	€	€	€	€	€	€	€	€	€	F	€	F	€	€	€	€	€	F
V çãK {~} ^	€	Í	€	Í	F	€	€	F	€	FF	€	FF	F	€	€	€	€	F
Á ÁQ ÉV çã	€	F€€	€	Á	F€€	€	€	Á	€	F€€	€	Á	F€€	€	€	€	€	Á
UPØ	€€€€	È G	€€€€	È G	€G	€	€€€€	€€€€	€G	€€€€	È €	€€€€	È €	€€€€	€€€€	€€€€	€G	È €

Ó[~}oÁM|ãããQ&E
 UUÁQ|cÁFíí
 Ó[í:]ããÖÖÁGíí
 QííFíGííÈíí

Óã Á -Áí } *ÁÓãã@
 ÞÉUíKíP^} í^ ÁQ íãÁQÉ^} ^
 ÖEY KíO^} } áUd^^c
 Y ^ãã@:KÁU"} } ^

ÖE^ Á þã ^ KÖÓÓP.ÖÖÓÚT
 Úã ÁÖ[á^ KÉÉÉÉÉÉÉF
 Úãã ÖÁã KÁGJHDEFG
 Úã Á ÁP[KÁG

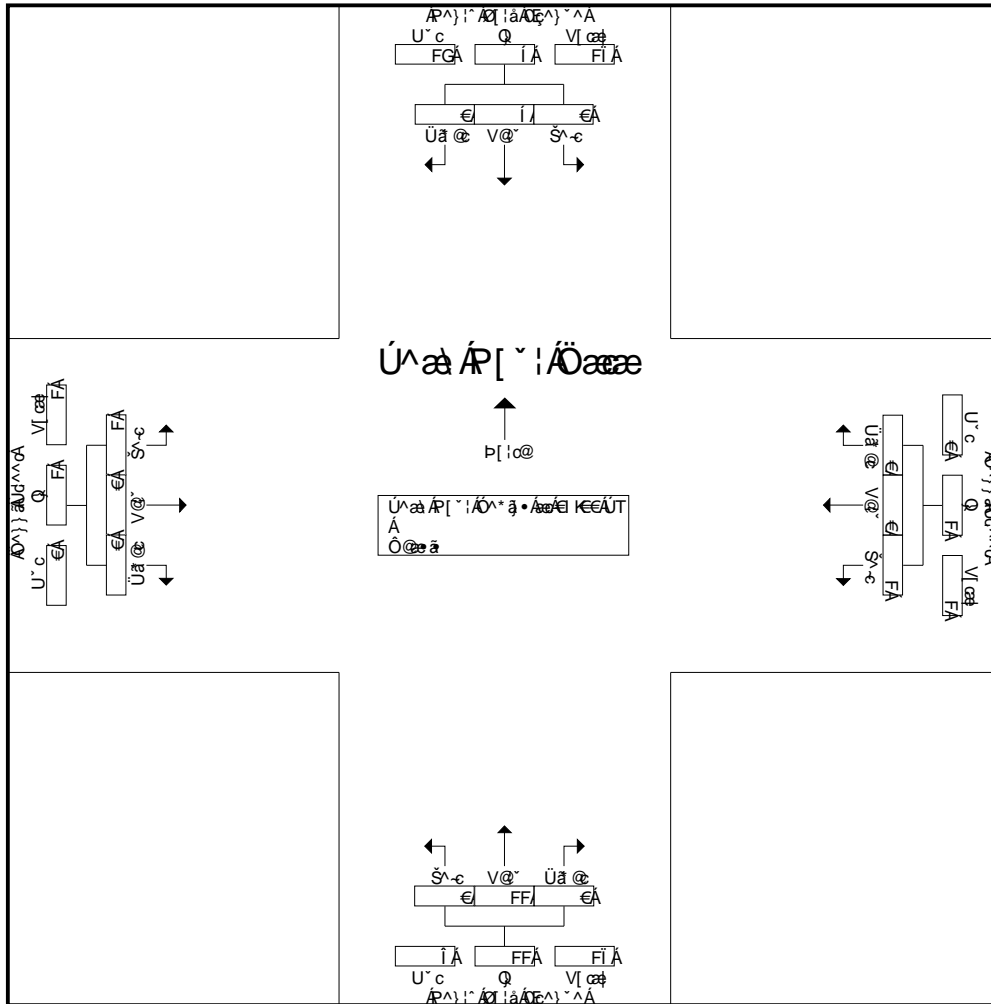

Úã ÁP[~}í:ÖÖãã } *ÁÓãã@
 Úã ÁP[~}í:ÖÖãã } *ÁÓãã@

ÉéÁ á • È	€	F	€	F	€	€	€	€	€	€	5	€	5	€	€	€	€
ÉFí Á á • È	€	2	€	2	€	€	€	€	€	€	H	€	H	€	€	€	€
ÉHéÁ á • È	€	G	€	G	€	€	€	€	€	€	G	€	G	€	€	€	€
Éí Á á • È	€	€	€	€	€	€	€	€	€	€	F	€	F	€	€	€	€
Ví cãKí{ ^	€	í	€	í	F	€	€	€	F	€	FF	€	FF	€	€	€	F
Á Áíí] ÉVí cã	€	Féé	€	Á	Féé	€	€	€	Á	€	Féé	€	Á	Féé	€	€	Á
ÚPÖ	€€€€	Èíí	€€€€	Èíí	€íí	€	€€€€	€€€€	€íí	€	€€€€	Èíí	€	€€€€	Èíí	€	€íí

Ó[] , o ÁM |ã, äããQ&E
 UUÁQ cAFÍI
 Ó[] } äÖÖÁGÍI
 QI FÁGÍ È GÍ

Óã Á -Á[] * ÁOã@
 ÞEUIKÁ } ! ÁQ |ãÁE } ^
 ÖEY KÁO } } äUd^^c
 Y ^ã@ : KÁ } } ^

ÖE Á Þ ä ^ KÖÓP ÖÖÖT
 Úã ÁÖ | ä ^ KEEEEEEF
 Úã@ Öã ^ KÖÖJ ÖEFG
 Úã ^ Á [KÖ

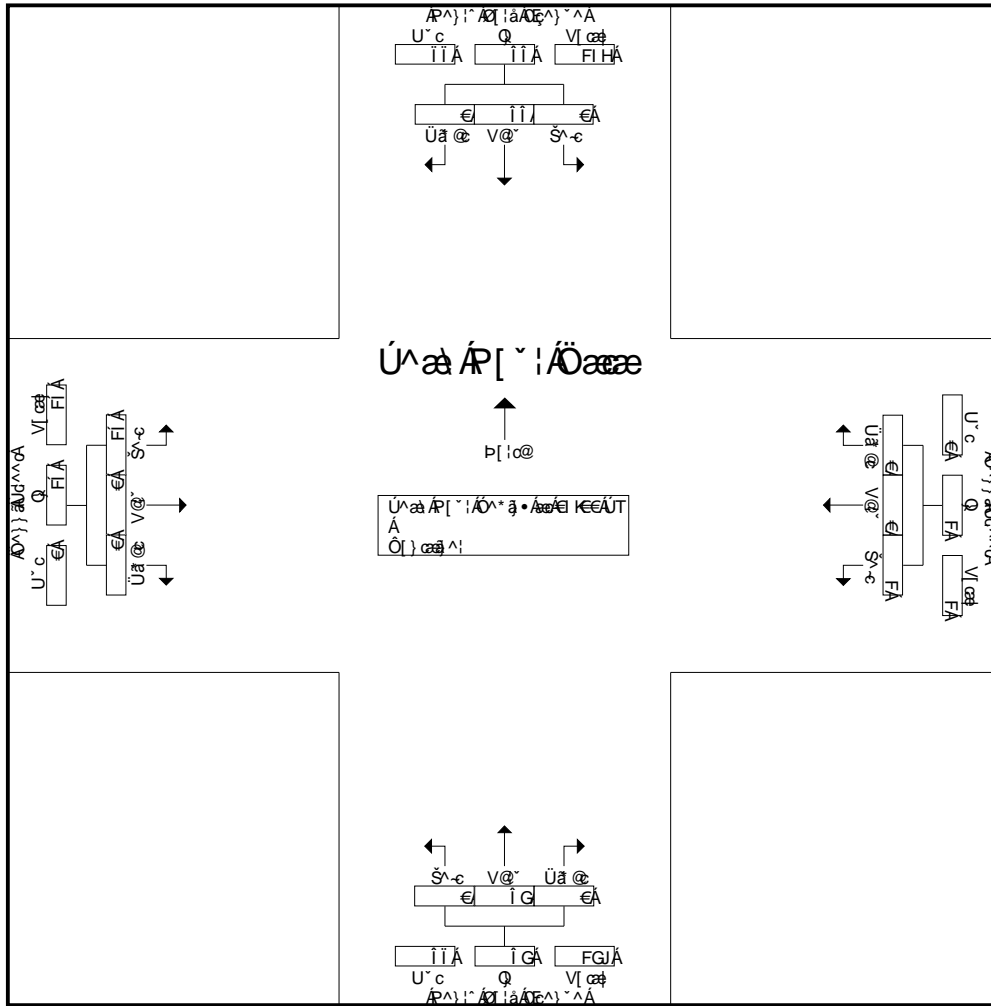

Úã ÁR [] ! ÖÖãã * ä ÁQ [] Ái keeÚT Ái Ái KÍ ÁÚT ÁUÚã ÁFÁ - ÁF
 Úã ÁR [] ! Ái ÖÖã@ [] ! } ä ÖÖÁ * ä * ÁãK

	ei keeÚT		ei keeÚT		ei keeÚT		ei keeÚT	
ÉÉÁ ä · È	€ 24	€ 24	€	€	€ 27	€ 27	G	€ € G
ÉFÍ Á ä · È	€ Fí	€ Fí	€	€	€ FH	€ FH	8	€ € € 8
ÉHEÁ ä · È	€ i	€ i	€	€	€ FH	€ FH	H	€ € € H
ÉÍ Á ä · È	€ Fí	€ Fí	1	€	€ J	€ J	G	€ € € G
Ví çáK [] { ^	€ íí	€ íí	F	€	€ ÍG	€ ÍG	Fí	€ € € Fí
Á ÁÖ [] ÉVí çá	€ FEE	€ Á	FEE	€	€ FEE	€ Á	FEE	€ € € Á
ÚPÖ	€€€ Èíí	€€€ Èíí	€€€ Èíí	€€€ Èíí	€€€ Èíí	€€€ Èíí	ÈíJ	€€€ €€€ ÈíJ

Ö|~}oÁM|ä ä^áQ&É
 UUÁÖ|cÁFIÍ
 Ö|{)}äÖÖÁGÍÍ
 QIFDÖIÉGI

Öä: Á-Á[}*Á^ä&@
 PBUK^)*ÁQ|äÁÖ^)*^
 ÖBY KÖ^)*äUd^^c
 Y^ä&@:KÁ^)*^

Ö^Áp&^ KÖÖPÖÖÖÜT
 Uä^ÁÖ|ä^ KÖÖÖÖÖÖF
 Uöä^Öä^ KÖÖJÖÖEFG
 Uä^ÁÁ| KÖ

Ö|~}*ÁUä c^áUc@:Á/Í^&•

UöäcÁ/ä ^	P^)*ÁQ äÁÖ^)*^ UÍ^c@ ~}ä				Ö^)}äUd^^c Y^*cà ~}ä				P^)*ÁQ äÁÖ^)*^ P {c@ ~}ä				Ö^)}äUd^^c Öäcà ~}ä				Q dÄV c&
	Š^c	V@~	Uä @	Q ÄV c&	Š^c	V@~	Uä @	Q ÄV c&	Š^c	V@~	Uä @	Q ÄV c&	Š^c	V@~	Uä @	Q ÄV c&	
€ KEEÁUT	G	í	€	í	€	€	G	G	€	H	G	í	F	€	€	F	Fí
€ KÍ ÁUT	€	F	€	F	€	€	H	H	€	G	F	H	€	€	€	€	í
€ KKEÁUT	€	G	€	G	€	€	G	G	€	G	F	H	€	€	€	€	í
€ KÍ ÁUT	€	G	€	G	€	F	F	G	€	G	€	G	F	F	€	€	í
V c&	G	FF	€	FH	€	F	í	J	€	J	í	FH	G	F	€	H	Hí
€ KEEÁUT	€	F	€	F	€	H	í	í	€	€	€	€	F	€	€	F	F€
€ KÍ ÁUT	€	F	€	F	€	€	H	H	€	H	F	í	€	€	€	€	í
€ KKEÁUT	€	€	€	€	F	€	G	H	€	H	í	í	€	€	€	€	F€
€ KÍ ÁUT	€	€	€	€	G	€	F	H	€	G	€	G	F	€	€	F	í
V c&	€	G	€	G	H	H	FF	Fí	€	í	í	FH	G	€	€	G	Hí
Ö :ä äÁ c&	G	FH	€	Fí	H	í	FJ	Gí	€	Fí	J	Gí	í	F	€	í	íG
Q : &ÖÁ	FHí	ííÉ	€	Á	FFÉ	FíÉ	íHÉ	Á	€	ííÉ	HíÉ	Á	í€	ÖÉ	€	Á	Á
V c&Á	GÉ	FíÉ	€	ÖÉ	íÉ	íÉ	GíÉ	HíÉ	€	GíÉ	FÖÉ	HíÉ	íÉ	FÉ	€	íÉ	

UöäcÁ/ä ^	P^)*ÁQ äÁÖ^)*^ UÍ^c@ ~}ä				Ö^)}äUd^^c Y^*cà ~}ä				P^)*ÁQ äÁÖ^)*^ P {c@ ~}ä				Ö^)}äUd^^c Öäcà ~}ä				Q dÄV c&
	Š^c	V@~	Uä @	Q ÄV c&	Š^c	V@~	Uä @	Q ÄV c&	Š^c	V@~	Uä @	Q ÄV c&	Š^c	V@~	Uä @	Q ÄV c&	
U^ä äÁ ~ ÁÖ :ä *ä ÁÖ { ÁE KEEÁUT ÁE KÍ ÁUT ÁU^ä äÁ-Á																	
U^ä äÁ ~ ÁÖ :ä *ä ÁÖ { ÁE KEEÁUT																	
€ KEEÁUT	2	6	€	8	€	€	G	G	€	3	2	5	1	€	€	F	16
€ KÍ ÁUT	€	F	€	F	€	€	3	3	€	G	F	H	€	€	€	€	í
€ KKEÁUT	€	G	€	G	€	€	G	G	€	G	F	H	€	€	€	€	í
€ KÍ ÁUT	€	G	€	G	€	1	F	G	€	G	€	G	F	1	€	2	í
V c&K ~ ^	G	FF	€	FH	€	F	í	J	€	J	í	FH	G	F	€	H	Hí
Á ÁÖ :ä V c&	FíÉ	ííÉ	€	Á	€	FFÉ	ííÉ	Á	€	íJÉ	HíÉ	Á	ííÉ	HíÉ	€	H	Á
UPØ	É€	Éí	É€€	Éí	É€€	É€	Éí	Éí€	É€€	Éí€	É€€	Éí€	É€€	É€	É€€	Éí	ÉJí

01 ~ } o ÁM |ã ä á Q&E
 UUÁO cAFI I
 ÔI () aZOOAG I I
 QI FDG i E G I

Ôã Á -Sj } * Á^as@
 BDUK^) : ^ QI |ã ÁE^) ^
 OBY KQF as@ ä ÁUd^^c
 Y ^as@ :KÁ } } ^

QY^ Á aë ^ KSOOP. QOE CE
 Úã ÁO [ä^ KCCCCCF
 Úã á Oã^ KCBJDEFG
 Úã ^ Á [K&

Groups Printed- Passenger Vehicles - Bobtail Trucks - Chasis Only Trucks - Container Trucks - Other Trucks

Start Time	Henry Ford Avenue Southbound				Anaheim Street Westbound				Henry Ford Avenue Northbound				Anaheim Street Eastbound				Int. Total
	Left	Thru	Right	App. Total	Left	Thru	Right	App. Total	Left	Thru	Right	App. Total	Left	Thru	Right	App. Total	
07:00 AM	9	13	4	26	11	171	18	200	7	5	10	22	10	185	61	256	504
07:15 AM	13	24	2	39	12	194	16	222	9	4	15	28	12	187	93	292	581
07:30 AM	13	36	7	56	18	198	15	231	7	4	4	15	14	175	61	250	552
07:45 AM	14	31	6	51	16	199	24	239	10	13	9	32	20	149	42	211	533
Total	49	104	19	172	57	762	73	892	33	26	38	97	56	696	257	1009	2170
08:00 AM	16	40	4	60	11	166	23	200	10	5	4	19	16	152	28	196	475
08:15 AM	25	41	5	71	16	147	16	179	15	12	10	37	18	134	26	178	465
08:30 AM	19	32	5	56	25	149	19	193	10	13	13	36	12	161	36	209	494
08:45 AM	18	31	5	54	14	142	22	178	17	20	14	51	11	119	23	153	436
Total	78	144	19	241	66	604	80	750	52	50	41	143	57	566	113	736	1870
Grand Total	127	248	38	413	123	1366	153	1642	85	76	79	240	113	1262	370	1745	4040
Apprch %	30.8	60	9.2		7.5	83.2	9.3		35.4	31.7	32.9		6.5	72.3	21.2		
Total %	3.1	6.1	0.9	10.2	3	33.8	3.8	40.6	2.1	1.9	2	5.9	2.8	31.2	9.2	43.2	
Passenger Vehicles	92	56	32	180	87	1260	137	1484	64	38	60	162	82	991	277	1350	3176
% Passenger Vehicles	72.4	22.6	84.2	43.6	70.7	92.2	89.5	90.4	75.3	50	75.9	67.5	72.6	78.5	74.9	77.4	78.6
Bobtail Trucks	18	82	2	102	22	16	5	43	7	21	10	38	15	76	68	159	342
% Bobtail Trucks	14.2	33.1	5.3	24.7	17.9	1.2	3.3	2.6	8.2	27.6	12.7	15.8	13.3	6	18.4	9.1	8.5
Chasis Only Trucks	0	18	0	18	0	0	0	0	1	2	0	3	0	7	6	13	34
% Chasis Only Trucks	0	7.3	0	4.4	0	0	0	0	1.2	2.6	0	1.2	0	0.6	1.6	0.7	0.8
Container Trucks	11	83	2	96	8	13	5	26	10	12	5	27	9	132	15	156	305
% Container Trucks	8.7	33.5	5.3	23.2	6.5	1	3.3	1.6	11.8	15.8	6.3	11.2	8	10.5	4.1	8.9	7.5
Other Trucks	6	9	2	17	6	77	6	89	3	3	4	10	7	56	4	67	183
% Other Trucks	4.7	3.6	5.3	4.1	4.9	5.6	3.9	5.4	3.5	3.9	5.1	4.2	6.2	4.4	1.1	3.8	4.5

Start Time	Henry Ford Avenue Southbound				Anaheim Street Westbound				Henry Ford Avenue Northbound				Anaheim Street Eastbound				Int. Total
	Left	Thru	Right	App. Total	Left	Thru	Right	App. Total	Left	Thru	Right	App. Total	Left	Thru	Right	App. Total	
07:00 AM	9	13	4	26	11	171	18	200	7	5	10	22	10	185	61	256	504
07:15 AM	13	24	2	39	12	194	16	222	9	4	15	28	12	187	93	292	581
07:30 AM	13	36	7	56	18	198	15	231	7	4	4	15	14	175	61	250	552
07:45 AM	14	31	6	51	16	199	24	239	10	13	9	32	20	149	42	211	533
Total Volume	49	104	19	172	57	762	73	892	33	26	38	97	56	696	257	1009	2170
% App. Total	28.5	60.5	11		6.4	85.4	8.2		34	26.8	39.2		5.6	69	25.5		
PHF	.875	.722	.679	.768	.792	.957	.760	.933	.825	.500	.633	.758	.700	.930	.691	.864	.934

Peak Hour Analysis From 07:00 AM to 08:45 AM - Peak 1 of 1

Peak Hour for Entire Intersection Begins at 07:00 AM

Ô[~ } • ÁM |ã äãÁQ&É
 UUÁQ cÁFII
 Ô[!|} äÖÖÁGII
 QI FÁG I È G I

Ôã Á -Á[] * ÁÖã@
 ÞEUIKÁ^) : ÁQ |ãÁE^) ^
 ÖEY KÁE ä@ ä ÁUd^^c
 Y ^ã@ : KÁU } } ^

ÖE^ Á ä ^ KÖÓP ÖE ÖE
 Úã ÁÖ[ä^ KEEEEÉ F
 Úã@ Öã^ KÁEJ B E F G
 Úã ^ Á[KÁG

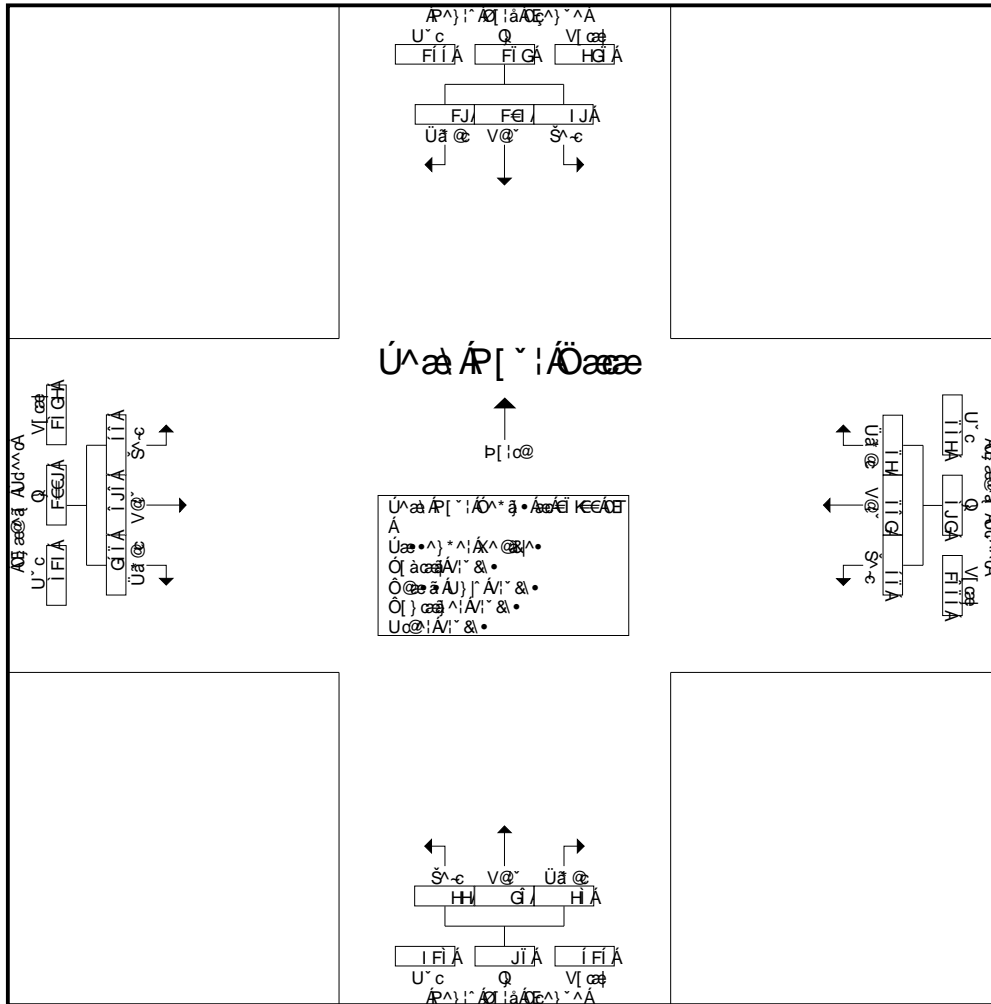

Úã ÁR[~ | ÁÖãæ • ä ÁÖ[{ ÁE KEEÖ ÁE ÁE K I ÁE ÁU^ ä ÁE Á - ÁE
 Peak Hour for Each Approach Begins at:

	08:00 AM				07:00 AM				08:00 AM				07:00 AM			
+0 mins.	16	40	4	60	11	171	18	200	10	5	4	19	10	185	61	256
+15 mins.	25	41	5	71	12	194	16	222	15	12	10	37	12	187	93	292
+30 mins.	19	32	5	56	18	198	15	231	10	13	13	36	14	175	61	250
+45 mins.	18	31	5	54	16	199	24	239	17	20	14	51	20	149	42	211
Total Volume	78	144	19	241	57	762	73	892	52	50	41	143	56	696	257	1009
% App. Total	32.4	59.8	7.9		6.4	85.4	8.2		36.4	35	28.7		5.6	69	25.5	
PHF	.780	.878	.950	.849	.792	.957	.760	.933	.765	.625	.732	.701	.700	.930	.691	.864

01 ~ } 0 AM | a a a Q & E
 UU A O c A F I I
 O I () a 200 A G I I
 Q I F D G I E G I

O a r A - S () * A ^ a s @
 P B U J K P ^) ! ^ A Q | a A C E ^) ^ ^
 O E Y K O F a s @ a A U d ^ ^ c
 Y ^ a s @ : K U } } ^

O E ^ A a s ^ K S O O P O E P O E
 U a r A O [a ^ K C E C E C E F
 U c a s O a s ^ K C B J B D E F G
 U a s ^ A p [K F

Groups Printed- Passenger Vehicles

Start Time	Henry Ford Avenue Southbound				Anaheim Street Westbound				Henry Ford Avenue Northbound				Anaheim Street Eastbound				Int. Total
	Left	Thru	Right	App. Total	Left	Thru	Right	App. Total	Left	Thru	Right	App. Total	Left	Thru	Right	App. Total	
07:00 AM	6	6	3	15	9	161	14	184	7	3	10	20	8	155	52	215	434
07:15 AM	9	6	2	17	10	182	13	205	9	4	14	27	8	159	82	249	498
07:30 AM	9	10	5	24	11	185	14	210	6	2	3	11	11	140	50	201	446
07:45 AM	10	9	4	23	9	181	21	211	6	10	7	23	16	123	25	164	421
Total	34	31	14	79	39	709	62	810	28	19	34	81	43	577	209	829	1799
08:00 AM	10	13	3	26	10	155	21	186	10	4	4	18	9	114	19	142	372
08:15 AM	20	5	5	30	13	131	16	160	13	7	7	27	14	99	17	130	347
08:30 AM	14	3	5	22	15	135	17	167	5	3	9	17	9	113	21	143	349
08:45 AM	14	4	5	23	10	130	21	161	8	5	6	19	7	88	11	106	309
Total	58	25	18	101	48	551	75	674	36	19	26	81	39	414	68	521	1377
Grand Total	92	56	32	180	87	1260	137	1484	64	38	60	162	82	991	277	1350	3176
Apprch %	51.1	31.1	17.8		5.9	84.9	9.2		39.5	23.5	37		6.1	73.4	20.5		
Total %	2.9	1.8	1	5.7	2.7	39.7	4.3	46.7	2	1.2	1.9	5.1	2.6	31.2	8.7	42.5	

Start Time	Henry Ford Avenue Southbound				Anaheim Street Westbound				Henry Ford Avenue Northbound				Anaheim Street Eastbound				Int. Total
	Left	Thru	Right	App. Total	Left	Thru	Right	App. Total	Left	Thru	Right	App. Total	Left	Thru	Right	App. Total	
07:00 AM	6	6	3	15	9	161	14	184	7	3	10	20	8	155	52	215	434
07:15 AM	9	6	2	17	10	182	13	205	9	4	14	27	8	159	82	249	498
07:30 AM	9	10	5	24	11	185	14	210	6	2	3	11	11	140	50	201	446
07:45 AM	10	9	4	23	9	181	21	211	6	10	7	23	16	123	25	164	421
Total Volume	34	31	14	79	39	709	62	810	28	19	34	81	43	577	209	829	1799
% App. Total	43	39.2	17.7		4.8	87.5	7.7		34.6	23.5	42		5.2	69.6	25.2		
PHF	.850	.775	.700	.823	.886	.958	.738	.960	.778	.475	.607	.750	.672	.907	.637	.832	.903

Peak Hour Analysis From 07:00 AM to 07:45 AM - Peak 1 of 1

Peak Hour for Entire Intersection Begins at 07:00 AM

Ô[~ } , o ÁM |ã ,ããÁQ&E
 UUÁQ c ÁFII
 Ô[!|}ããÖÖÁGii
 QI FÁG i È ð i

Ôã Á -Á[] * Á^ãã@
 ÞEUIKÁ^) : ÁQ |ãÁE^) ^
 ÖEY KÁQF äã@ ä ÁUd^^c
 Y ^ãã@ : KÁU } } ^

ÖE Á Þ ä ^ KÖÓP ÖE Þ ÖE
 Úã ÁÖ[ä^ KEEEEÉ F
 Úãã Ö Öã^ KÁGJ BDEFG
 Úãã Á Þ [KÁG

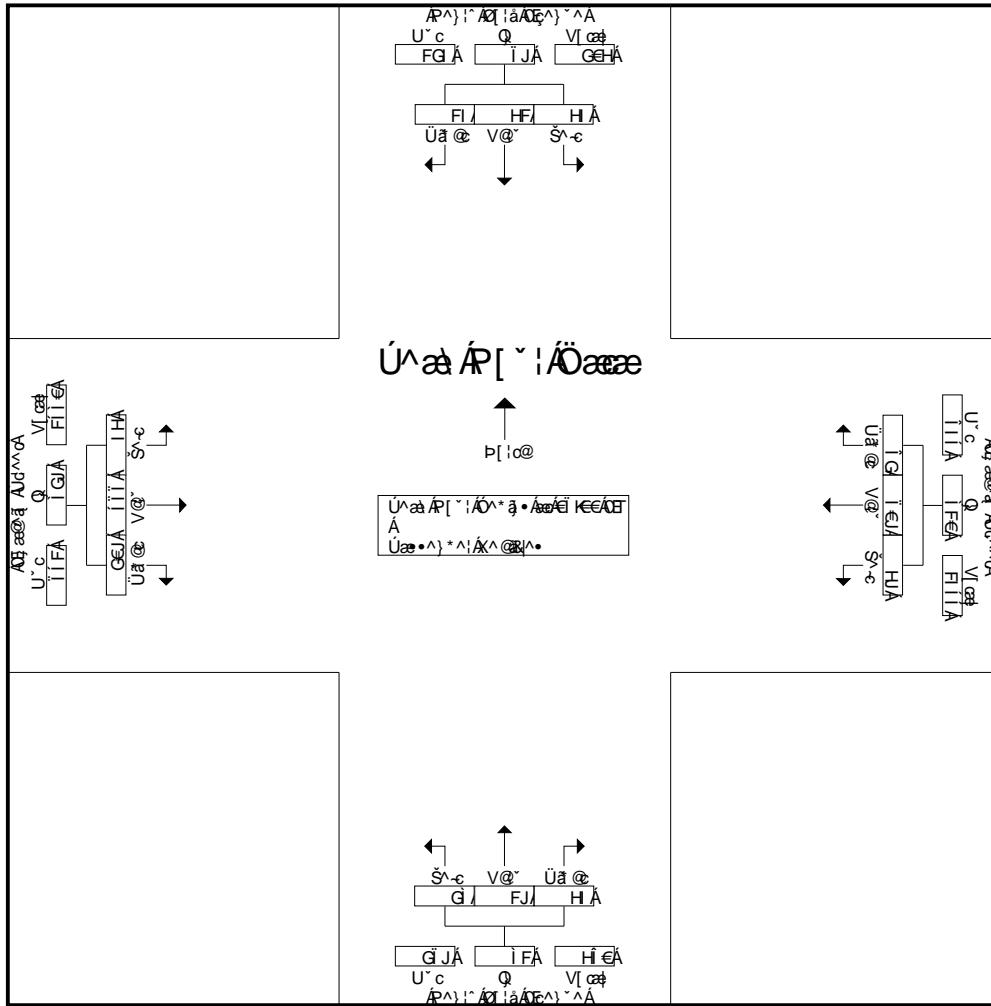

Úãã Á Þ [~ ! ÁQF äã * ä ÁQ[{ ÁE KEEÖE ÁE ÁE K ÁE ÁE ÁU^ãã ÁE ÁE -ÁE
 Peak Hour for Each Approach Begins at:

	07:00 AM				07:00 AM				07:00 AM				07:00 AM			
+0 mins.	6	6	3	15	9	161	14	184	7	3	10	20	8	155	52	215
+15 mins.	9	6	2	17	10	182	13	205	9	4	14	27	8	159	82	249
+30 mins.	9	10	5	24	11	185	14	210	6	2	3	11	11	140	50	201
+45 mins.	10	9	4	23	9	181	21	211	6	10	7	23	16	123	25	164
Total Volume	34	31	14	79	39	709	62	810	28	19	34	81	43	577	209	829
% App. Total	43	39.2	17.7		4.8	87.5	7.7		34.6	23.5	42		5.2	69.6	25.2	
PHF	.850	.775	.700	.823	.886	.958	.738	.960	.778	.475	.607	.750	.672	.907	.637	.832

01 } 0 AM | a a a Q & E
 UU A c A F I I
 01 () a 00 A G I I
 Q I F D G I E G I

0 a A - S () * A ^ a s @
 P B U J K P ^) : ^ A Q | a A C E ^) ^ ^
 O E Y K O E a s @ a A U d ^ ^ c
 Y ^ a s @ : K U } } ^

0 1 ^ P a s ^ K S O O P . 0 0 P C E F
 U a ^ A O [a ^ K C E C C C C E F
 U a s ^ O a s ^ K C B J B D E F G
 U a s ^ A P [K F

Groups Printed- Bobtail Trucks

Start Time	Henry Ford Avenue Southbound				Anaheim Street Westbound				Henry Ford Avenue Northbound				Anaheim Street Eastbound				Int. Total
	Left	Thru	Right	App. Total	Left	Thru	Right	App. Total	Left	Thru	Right	App. Total	Left	Thru	Right	App. Total	
07:00 AM	0	3	0	3	1	2	2	5	0	1	0	1	0	6	8	14	23
07:15 AM	3	8	0	11	2	2	0	4	0	0	1	1	2	6	7	15	31
07:30 AM	3	9	1	13	1	0	0	1	0	2	0	2	0	13	6	19	35
07:45 AM	1	13	1	15	5	4	1	10	2	1	1	4	2	12	14	28	57
Total	7	33	2	42	9	8	3	20	2	4	2	8	4	37	35	76	146
08:00 AM	5	14	0	19	1	2	1	4	0	0	0	0	3	12	7	22	45
08:15 AM	3	13	0	16	2	3	0	5	0	5	1	6	2	6	3	11	38
08:30 AM	2	10	0	12	7	3	1	11	1	6	3	10	3	11	13	27	60
08:45 AM	1	12	0	13	3	0	0	3	4	6	4	14	3	10	10	23	53
Total	11	49	0	60	13	8	2	23	5	17	8	30	11	39	33	83	196
Grand Total	18	82	2	102	22	16	5	43	7	21	10	38	15	76	68	159	342
Apprch %	17.6	80.4	2		51.2	37.2	11.6		18.4	55.3	26.3		9.4	47.8	42.8		
Total %	5.3	24	0.6	29.8	6.4	4.7	1.5	12.6	2	6.1	2.9	11.1	4.4	22.2	19.9	46.5	

Start Time	Henry Ford Avenue Southbound				Anaheim Street Westbound				Henry Ford Avenue Northbound				Anaheim Street Eastbound				Int. Total
	Left	Thru	Right	App. Total	Left	Thru	Right	App. Total	Left	Thru	Right	App. Total	Left	Thru	Right	App. Total	
07:00 AM	0	3	0	3	1	2	2	5	0	1	0	1	0	6	8	14	23
07:15 AM	3	8	0	11	2	2	0	4	0	0	1	1	2	6	7	15	31
07:30 AM	3	9	1	13	1	0	0	1	0	2	0	2	0	13	6	19	35
07:45 AM	1	13	1	15	5	4	1	10	2	1	1	4	2	12	14	28	57
Total Volume	7	33	2	42	9	8	3	20	2	4	2	8	4	37	35	76	146
% App. Total	16.7	78.6	4.8		45	40	15		25	50	25		5.3	48.7	46.1		
PHF	.583	.635	.500	.700	.450	.500	.375	.500	.250	.500	.500	.500	.500	.712	.625	.679	.640

Peak Hour Analysis From 07:00 AM to 07:45 AM - Peak 1 of 1
 Peak Hour for Entire Intersection Begins at 07:00 AM

0[^ } o AM | a a a Q & E
 UU A Q c A F I I
 0[| | } a a O A G I i
 Q I F D G i E d i

0 a r A - S [] * A ^ a s @
 P E U I K P ^) : ^ A Q | a A C E ^) ^ ^
 O E Y K A Q E a s @ a A U d ^ ^ c
 Y ^ a s @ : K A U ^ } } ^

0 E ^ A p a s ^ K S O P O E P C E T
 U a r A O [a ^ K E E E E E F
 U c a s c O a e ^ K C B J B E F G
 U a s ^ A p [K G

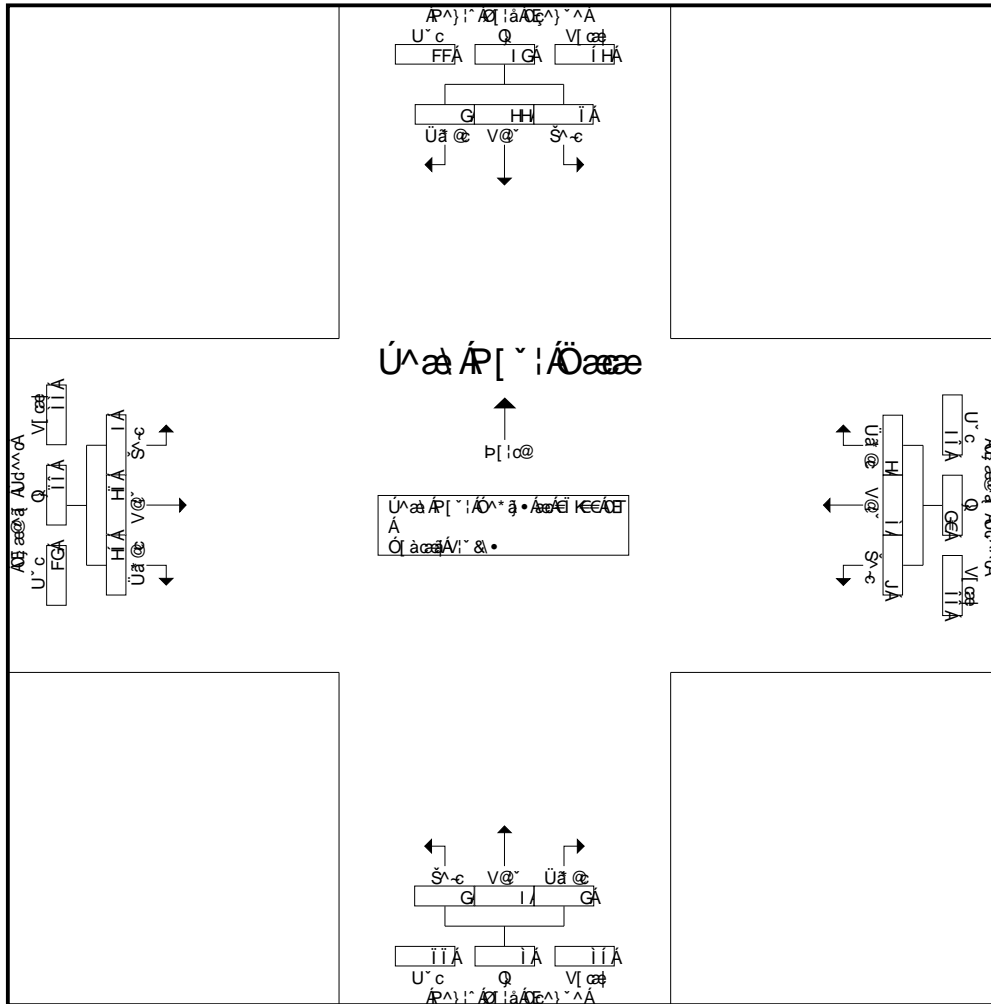

U ^ a s A R [^ : I A O a e e a A O [{ A I K E E C E F A I A I K I A C E A U ^ a s A A - A
 Peak Hour for Each Approach Begins at:

	07:00 AM				07:00 AM				07:00 AM				07:00 AM			
+0 mins.	0	3	0	3	1	2	2	5	0	1	0	1	0	6	8	14
+15 mins.	3	8	0	11	2	2	0	4	0	0	1	1	2	6	7	15
+30 mins.	3	9	1	13	1	0	0	1	0	2	0	2	0	13	6	19
+45 mins.	1	13	1	15	5	4	1	10	2	1	1	4	2	12	14	28
Total Volume	7	33	2	42	9	8	3	20	2	4	2	8	4	37	35	76
% App. Total	16.7	78.6	4.8		45	40	15		25	50	25		5.3	48.7	46.1	
PHF	.583	.635	.500	.700	.450	.500	.375	.500	.250	.500	.500	.500	.500	.712	.625	.679

01 ~ } 0 AM | a a a Q & E
 UU A O c A F I I
 O I () a z O C A G I I
 Q I F D G I E G I

O a A - S j } * A ^ a s @
 P B U J K P ^ } ! ^ A Q | a A C E ^ } ^ ^
 O E Y K O F a s @ a A U d ^ ^ c
 Y ^ a s @ : K U } } ^

O E ^ A a s ^ K S O O P O C E F
 U a A O [a ^ K C E C C C E F
 U a s O a s ^ K C B J B E F G
 U a s ^ A [K F

Groups Printed- Chasis Only Trucks

Start Time	Henry Ford Avenue Southbound				Anaheim Street Westbound				Henry Ford Avenue Northbound				Anaheim Street Eastbound				Int. Total
	Left	Thru	Right	App. Total	Left	Thru	Right	App. Total	Left	Thru	Right	App. Total	Left	Thru	Right	App. Total	
07:00 AM	0	1	0	1	0	0	0	0	0	0	0	0	0	0	1	1	2
07:15 AM	0	0	0	0	0	0	0	0	0	0	0	0	0	0	2	2	2
07:30 AM	0	5	0	5	0	0	0	0	0	0	0	0	0	1	2	3	8
07:45 AM	0	1	0	1	0	0	0	0	0	0	0	0	0	1	0	1	2
Total	0	7	0	7	0	0	0	0	0	0	0	0	0	2	5	7	14
08:00 AM	0	3	0	3	0	0	0	0	0	0	0	0	0	1	0	1	4
08:15 AM	0	5	0	5	0	0	0	0	0	0	0	0	0	1	1	2	7
08:30 AM	0	1	0	1	0	0	0	0	1	1	0	2	0	1	0	1	4
08:45 AM	0	2	0	2	0	0	0	0	0	1	0	1	0	2	0	2	5
Total	0	11	0	11	0	0	0	0	1	2	0	3	0	5	1	6	20
Grand Total	0	18	0	18	0	0	0	0	1	2	0	3	0	7	6	13	34
Apprch %	0	100	0		0	0	0		33.3	66.7	0		0	53.8	46.2		
Total %	0	52.9	0	52.9	0	0	0	0	2.9	5.9	0	8.8	0	20.6	17.6	38.2	

Start Time	Henry Ford Avenue Southbound				Anaheim Street Westbound				Henry Ford Avenue Northbound				Anaheim Street Eastbound				Int. Total
	Left	Thru	Right	App. Total	Left	Thru	Right	App. Total	Left	Thru	Right	App. Total	Left	Thru	Right	App. Total	
07:00 AM	0	1	0	1	0	0	0	0	0	0	0	0	0	0	1	1	2
07:15 AM	0	0	0	0	0	0	0	0	0	0	0	0	0	0	2	2	2
07:30 AM	0	5	0	5	0	0	0	0	0	0	0	0	0	1	2	3	8
07:45 AM	0	1	0	1	0	0	0	0	0	0	0	0	0	1	0	1	2
Total Volume	0	7	0	7	0	0	0	0	0	0	0	0	0	2	5	7	14
% App. Total	0	100	0		0	0	0		0	0	0		0	28.6	71.4		
PHF	.000	.350	.000	.350	.000	.000	.000	.000	.000	.000	.000	.000	.000	.500	.625	.583	.438

Peak Hour Analysis From 07:00 AM to 07:45 AM - Peak 1 of 1

Peak Hour for Entire Intersection Begins at 07:00 AM

0[^ } o AM | a a a Q & E
 UU A Q c A F I I
 0 [: [] a a Q A U G I i
 Q I F D G i E d i

0 a r A - S [] * A ^ a s @
 P E U J K P ^) : ^ A Q | a A C E ^) ^
 O E Y K A Q E a s @ a A U d ^ ^ c
 Y ^ a s @ : K A U ^ } } ^

0 E ^ A p a s ^ K S O P Q C E F
 U a r A O [a ^ K E E E E E F
 U a s c O a s ^ K C R J D E F G
 U a s ^ A p [K G

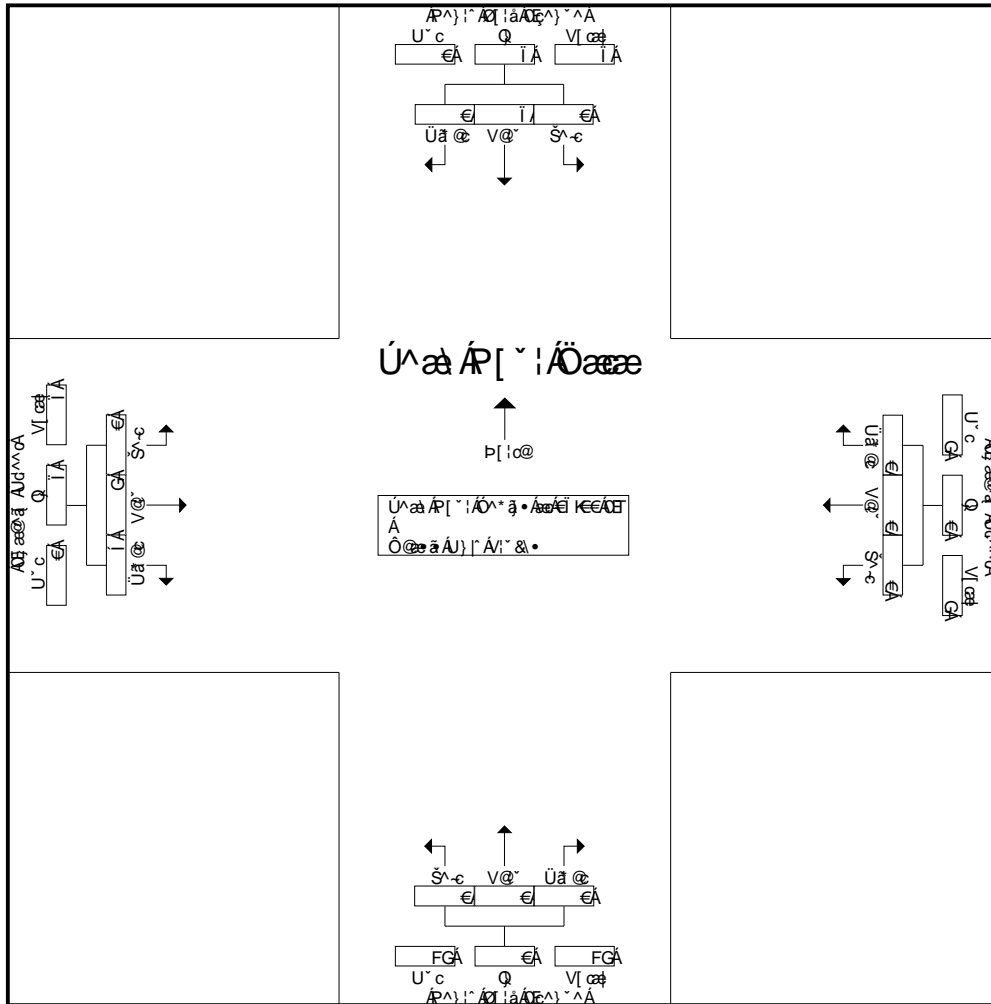

U^ a a A P [^ | A O a a e * a A O [{ A i K E C E F A i A i K I A C E A U ^ a A A - A
 Peak Hour for Each Approach Begins at:

	07:00 AM				07:00 AM				07:00 AM				07:00 AM			
+0 mins.	0	1	0	1	0	0	0	0	0	0	0	0	0	0	1	1
+15 mins.	0	0	0	0	0	0	0	0	0	0	0	0	0	0	2	2
+30 mins.	0	5	0	5	0	0	0	0	0	0	0	0	0	1	2	3
+45 mins.	0	1	0	1	0	0	0	0	0	0	0	0	0	1	0	1
Total Volume	0	7	0	7	0	0	0	0	0	0	0	0	0	2	5	7
% App. Total	0	100	0	0	0	0	0	0	0	0	0	0	0	28.6	71.4	0
PHF	.000	.350	.000	.350	.000	.000	.000	.000	.000	.000	.000	.000	.000	.500	.625	.583

Q[~}oAM|ãããQ&E
 UUO/cAFI
 O{[}ãZOOAGI
 QIFDGiE Gi

Oã A -Sj } * A^ã&@
 PBUK^P^} :^ Aq |ããE^ } ^
 OBY KOF ã@ã ÄUd^^c
 Y ^ã@:KÜ } } ^

Q^Aã ^ KSOOP.OEPE
 Uã AÖ[ãã KEEEEE F
 Uãã Oãã KCBJDEFG
 Uãã ^A[K^

Groups Printed- Container Trucks

Start Time	Henry Ford Avenue Southbound				Anaheim Street Westbound				Henry Ford Avenue Northbound				Anaheim Street Eastbound				Int. Total
	Left	Thru	Right	App. Total	Left	Thru	Right	App. Total	Left	Thru	Right	App. Total	Left	Thru	Right	App. Total	
07:00 AM	2	3	1	6	1	1	0	2	0	0	0	0	2	19	0	21	29
07:15 AM	1	10	0	11	0	0	1	1	0	0	0	0	1	17	1	19	31
07:30 AM	0	12	0	12	1	1	0	2	0	0	0	0	1	15	3	19	33
07:45 AM	3	7	0	10	2	3	2	7	2	1	0	3	1	7	3	11	31
Total	6	32	1	39	4	5	3	12	2	1	0	3	5	58	7	70	124
08:00 AM	0	9	1	10	0	0	1	1	0	1	0	1	3	19	2	24	36
08:15 AM	2	17	0	19	1	3	0	4	1	0	1	2	1	20	3	24	49
08:30 AM	1	14	0	15	2	3	0	5	3	2	0	5	0	27	1	28	53
08:45 AM	2	11	0	13	1	2	1	4	4	8	4	16	0	8	2	10	43
Total	5	51	1	57	4	8	2	14	8	11	5	24	4	74	8	86	181
Grand Total	11	83	2	96	8	13	5	26	10	12	5	27	9	132	15	156	305
Apprch %	11.5	86.5	2.1		30.8	50	19.2		37	44.4	18.5		5.8	84.6	9.6		
Total %	3.6	27.2	0.7	31.5	2.6	4.3	1.6	8.5	3.3	3.9	1.6	8.9	3	43.3	4.9	51.1	

Start Time	Henry Ford Avenue Southbound				Anaheim Street Westbound				Henry Ford Avenue Northbound				Anaheim Street Eastbound				Int. Total
	Left	Thru	Right	App. Total	Left	Thru	Right	App. Total	Left	Thru	Right	App. Total	Left	Thru	Right	App. Total	
07:00 AM	2	3	1	6	1	1	0	2	0	0	0	0	2	19	0	21	29
07:15 AM	1	10	0	11	0	0	1	1	0	0	0	0	1	17	1	19	31
07:30 AM	0	12	0	12	1	1	0	2	0	0	0	0	1	15	3	19	33
07:45 AM	3	7	0	10	2	3	2	7	2	1	0	3	1	7	3	11	31
Total Volume	6	32	1	39	4	5	3	12	2	1	0	3	5	58	7	70	124
% App. Total	15.4	82.1	2.6		33.3	41.7	25		66.7	33.3	0		7.1	82.9	10		
PHF	.500	.667	.250	.813	.500	.417	.375	.429	.250	.250	.000	.250	.625	.763	.583	.833	.939

Peak Hour Analysis From 07:00 AM to 07:45 AM - Peak 1 of 1
 Peak Hour for Entire Intersection Begins at 07:00 AM

Ô[~}•ÁM|ãããÁQ&E
 UUÁQcÁFII
 Ô[!|}ããÖÁGII
 QI FÁG I È G I

Ôã Á -Á[]*Á^ãã@
 ÞEUIKÁ^!^ ÁQ |ãÁE^)^ ^
 ÖEY KÁEããã ÁUd^^c
 Y ^ãã@:KÁ^}}^

ÖE^ Áã ^ KÖÓP ÖE ÖE
 Úã ÁÖ |ã^ KEEEEÉ F
 Úãã ÖÁã KÁEJHDEFG
 Úã ^Á[KÁG

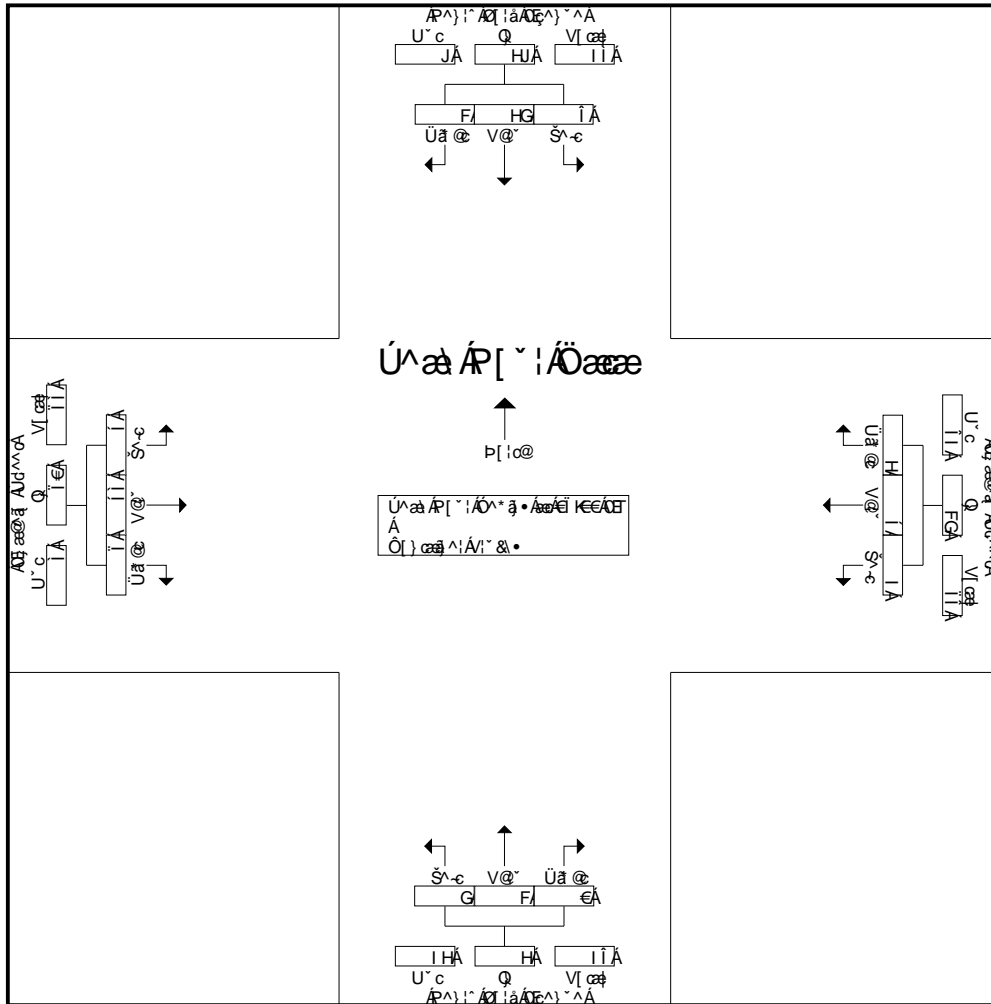

Úã ÁR[~ | ÁÖãã • ÁÁÖ[{ ÁE KEEÁE ÁE ÁE K I ÁE ÁU^ã ÁÁ Á-Á
 Peak Hour for Each Approach Begins at:

	07:00 AM				07:00 AM				07:00 AM				07:00 AM			
+0 mins.	2	3	1	6	1	1	0	2	0	0	0	0	2	19	0	21
+15 mins.	1	10	0	11	0	0	1	1	0	0	0	0	1	17	1	19
+30 mins.	0	12	0	12	1	1	0	2	0	0	0	0	1	15	3	19
+45 mins.	3	7	0	10	2	3	2	7	2	1	0	3	1	7	3	11
Total Volume	6	32	1	39	4	5	3	12	2	1	0	3	5	58	7	70
% App. Total	15.4	82.1	2.6		33.3	41.7	25		66.7	33.3	0		7.1	82.9	10	
PHF	.500	.667	.250	.813	.500	.417	.375	.429	.250	.250	.000	.250	.625	.763	.583	.833

01 ~ } 0 AM | a a a Q & E
 UU A O c A F I I
 O I () a z O O A G I I
 Q I F D G I E G I

O a A - S () * A ^ a s @
 P B U J K P ^) ! ^ A Q | a A C E ^) ^ ^
 O E Y K O E a s @ a A U d ^ ^ c
 Y ^ a s @ : K U } } ^

O E ^ A a s ^ K S O O P O C E F
 U a A O [a ^ K C E C C E C F
 U a s O a s ^ K C B J B E F G
 U a s ^ A [K F

Groups Printed- Other Trucks

Start Time	Henry Ford Avenue Southbound				Anaheim Street Westbound				Henry Ford Avenue Northbound				Anaheim Street Eastbound				Int. Total
	Left	Thru	Right	App. Total	Left	Thru	Right	App. Total	Left	Thru	Right	App. Total	Left	Thru	Right	App. Total	
07:00 AM	1	0	0	1	0	7	2	9	0	1	0	1	0	5	0	5	16
07:15 AM	0	0	0	0	0	10	2	12	0	0	0	0	1	5	1	7	19
07:30 AM	1	0	1	2	5	12	1	18	1	0	1	2	2	6	0	8	30
07:45 AM	0	1	1	2	0	11	0	11	0	1	1	2	1	6	0	7	22
Total	2	1	2	5	5	40	5	50	1	2	2	5	4	22	1	27	87
08:00 AM	1	1	0	2	0	9	0	9	0	0	0	0	1	6	0	7	18
08:15 AM	0	1	0	1	0	10	0	10	1	0	1	2	1	8	2	11	24
08:30 AM	2	4	0	6	1	8	1	10	0	1	1	2	0	9	1	10	28
08:45 AM	1	2	0	3	0	10	0	10	1	0	0	1	1	11	0	12	26
Total	4	8	0	12	1	37	1	39	2	1	2	5	3	34	3	40	96
Grand Total	6	9	2	17	6	77	6	89	3	3	4	10	7	56	4	67	183
Apprch %	35.3	52.9	11.8		6.7	86.5	6.7		30	30	40		10.4	83.6	6		
Total %	3.3	4.9	1.1	9.3	3.3	42.1	3.3	48.6	1.6	1.6	2.2	5.5	3.8	30.6	2.2	36.6	

Start Time	Henry Ford Avenue Southbound				Anaheim Street Westbound				Henry Ford Avenue Northbound				Anaheim Street Eastbound				Int. Total
	Left	Thru	Right	App. Total	Left	Thru	Right	App. Total	Left	Thru	Right	App. Total	Left	Thru	Right	App. Total	
07:00 AM	1	0	0	1	0	7	2	9	0	1	0	1	0	5	0	5	16
07:15 AM	0	0	0	0	0	10	2	12	0	0	0	0	1	5	1	7	19
07:30 AM	1	0	1	2	5	12	1	18	1	0	1	2	2	6	0	8	30
07:45 AM	0	1	1	2	0	11	0	11	0	1	1	2	1	6	0	7	22
Total Volume	2	1	2	5	5	40	5	50	1	2	2	5	4	22	1	27	87
% App. Total	40	20	40		10	80	10		20	40	40		14.8	81.5	3.7		
PHF	.500	.250	.500	.625	.250	.833	.625	.694	.250	.500	.500	.625	.500	.917	.250	.844	.725

Peak Hour Analysis From 07:00 AM to 07:45 AM - Peak 1 of 1

Peak Hour for Entire Intersection Begins at 07:00 AM

Ô[} , o ÁM |ã äããQ&É
 UUÁQ cÁFii
 Ô[!|} äããQ&Éii
 Q! FÁG i É G i

Ôã Á -Á[] * ÁOã@
 ÞEUIKÁ^! : ÁQ |ãÁE^ ^
 ÖEY KÁE ä@ ä ÁUd^^c
 Y ^ä@ : KÁU } } ^

ÖE^ Á ä ^ KÖÓP ÖE ÖE
 Úã ÁO | ä ^ KÉÉÉÉÉ F
 Úã c ÁO ä ^ KÁEJ B E F G
 Úã ^ Á [KÁG

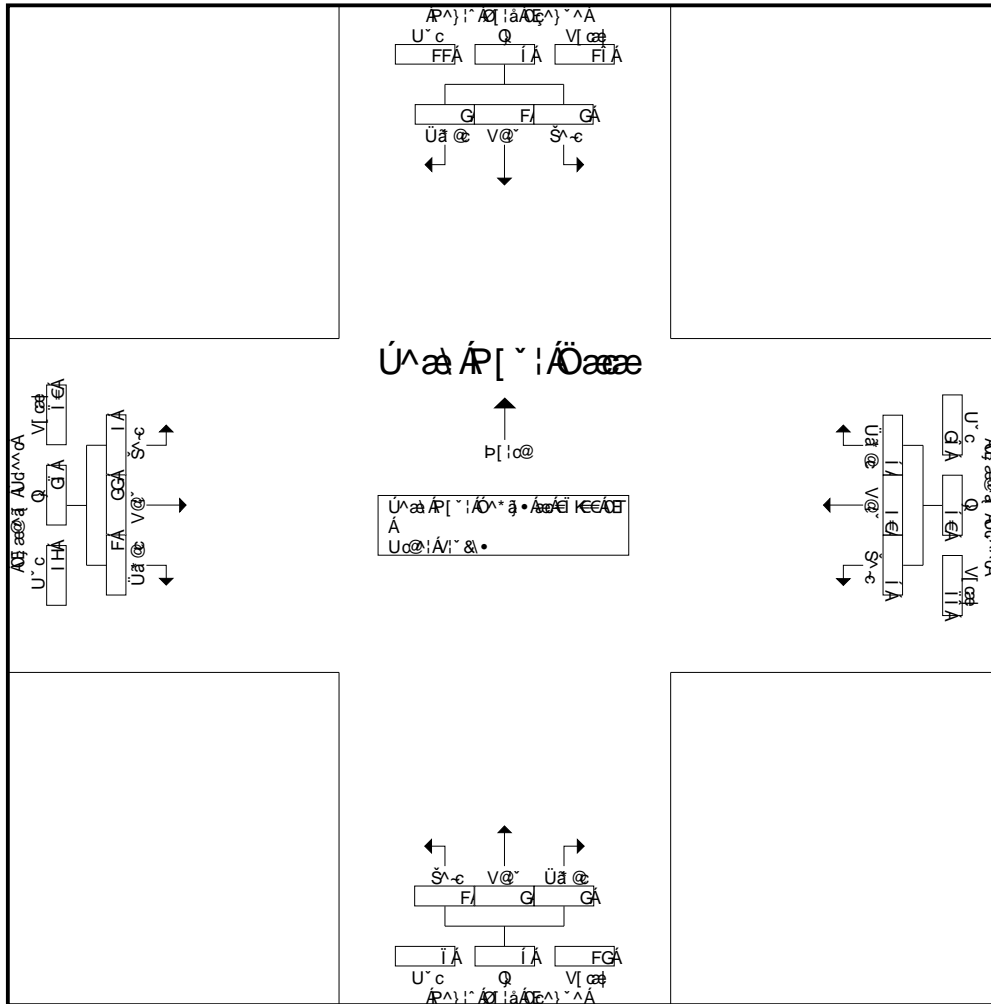

Úã ÁP[~ | ÁE ä ä ÁQ[{ ÁE KÉÉÉÉÉ ÁE K ÁE ÁU^ ä ÁÁ -Á
 Peak Hour for Each Approach Begins at:

	07:00 AM				07:00 AM				07:00 AM				07:00 AM			
+0 mins.	1	0	0	1	0	7	2	9	0	1	0	1	0	5	0	5
+15 mins.	0	0	0	0	0	10	2	12	0	0	0	0	1	5	1	7
+30 mins.	1	0	1	2	5	12	1	18	1	0	1	2	2	6	0	8
+45 mins.	0	1	1	2	0	11	0	11	0	1	1	2	1	6	0	7
Total Volume	2	1	2	5	5	40	5	50	1	2	2	5	4	22	1	27
% App. Total	40	20	40		10	80	10		20	40	40		14.8	81.5	3.7	
PHF	.500	.250	.500	.625	.250	.833	.625	.694	.250	.500	.500	.625	.500	.917	.250	.844

01:00 AM to 01:05 AM
 01:05 AM to 01:10 AM
 01:10 AM to 01:15 AM
 01:15 AM to 01:20 AM

01:00 AM to 01:05 AM
 01:05 AM to 01:10 AM
 01:10 AM to 01:15 AM
 01:15 AM to 01:20 AM

01:00 AM to 01:05 AM
 01:05 AM to 01:10 AM
 01:10 AM to 01:15 AM
 01:15 AM to 01:20 AM

Groups Printed- Bobtail Trucks

Start Time	Henry Ford Avenue Southbound				Anaheim Street Westbound				Henry Ford Avenue Northbound				Anaheim Street Eastbound				Int. Total
	Left	Thru	Right	App. Total	Left	Thru	Right	App. Total	Left	Thru	Right	App. Total	Left	Thru	Right	App. Total	
01:00 PM	3	5	1	9	1	4	2	7	2	5	1	8	0	9	3	12	36
01:15 PM	2	4	0	6	0	3	3	6	7	7	7	21	4	3	4	11	44
01:30 PM	1	8	0	9	1	5	2	8	10	15	4	29	1	12	4	17	63
01:45 PM	3	7	1	11	1	9	4	14	11	12	4	27	4	7	8	19	71
Total	9	24	2	35	3	21	11	35	30	39	16	85	9	31	19	59	214
02:00 PM	4	1	2	7	1	5	0	6	8	16	4	28	4	6	7	17	58
02:15 PM	1	3	0	4	2	14	3	19	9	16	7	32	1	8	5	14	69
02:30 PM	4	7	1	12	2	14	1	17	5	6	2	13	7	10	13	30	72
02:45 PM	2	6	0	8	3	4	2	9	3	8	6	17	4	5	9	18	52
Total	11	17	3	31	8	37	6	51	25	46	19	90	16	29	34	79	251
Grand Total	20	41	5	66	11	58	17	86	55	85	35	175	25	60	53	138	465
Apprch %	30.3	62.1	7.6		12.8	67.4	19.8		31.4	48.6	20		18.1	43.5	38.4		
Total %	4.3	8.8	1.1	14.2	2.4	12.5	3.7	18.5	11.8	18.3	7.5	37.6	5.4	12.9	11.4	29.7	

Start Time	Henry Ford Avenue Southbound				Anaheim Street Westbound				Henry Ford Avenue Northbound				Anaheim Street Eastbound				Int. Total
	Left	Thru	Right	App. Total	Left	Thru	Right	App. Total	Left	Thru	Right	App. Total	Left	Thru	Right	App. Total	
02:00 PM	4	1	2	7	1	5	0	6	8	16	4	28	4	6	7	17	58
02:15 PM	1	3	0	4	2	14	3	19	9	16	7	32	1	8	5	14	69
02:30 PM	4	7	1	12	2	14	1	17	5	6	2	13	7	10	13	30	72
02:45 PM	2	6	0	8	3	4	2	9	3	8	6	17	4	5	9	18	52
Total Volume	11	17	3	31	8	37	6	51	25	46	19	90	16	29	34	79	251
% App. Total	35.5	54.8	9.7		15.7	72.5	11.8		27.8	51.1	21.1		20.3	36.7	43		
PHF	.688	.607	.375	.646	.667	.661	.500	.671	.694	.719	.679	.703	.571	.725	.654	.658	.872

Peak Hour Analysis From 02:00 PM to 02:45 PM - Peak 1 of 1

Peak Hour for Entire Intersection Begins at 02:00 PM

0[^ } o AM | a a a Q & E
 UU A Q c A F F I I
 0 [: |] a a 0 0 A G I I
 Q I F D G I E G I

0 a t A - A [] * A ^ a s @
 P E U J K P ^) : ^ A Q | a A C E ^) ^
 O E Y K A Q E a s @ a A U d ^ ^ c
 Y ^ a s @ : K A U } } ^

0 a t A p a s ^ K S O O P O C E T O
 U a t A O [a ^ K E E E E E E F
 U a s o A a e ^ K G E U H D E F G
 U a s ^ A p [K G

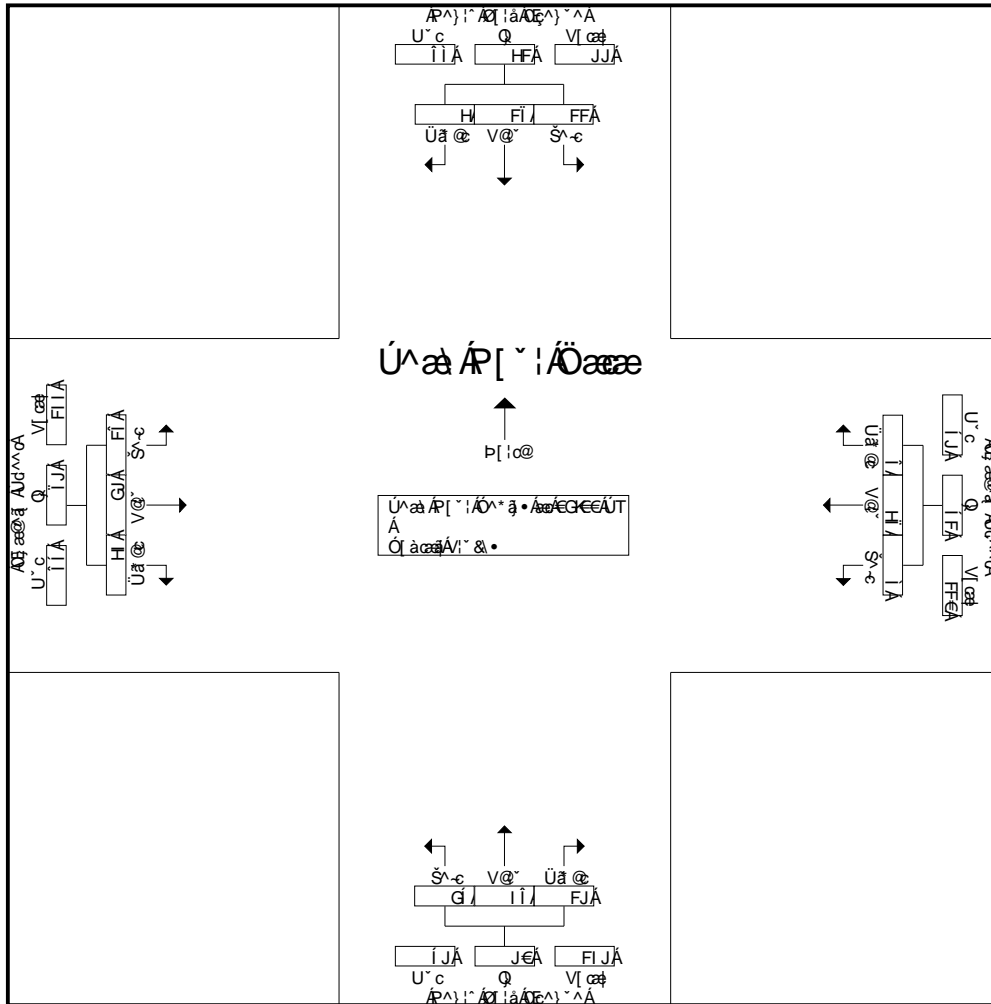

U a s A R [^ | A O a s a A O [{ A E G E E A U T A t A E G K I A U T A U U a s A A - A
 Peak Hour for Each Approach Begins at:

	02:00 PM				02:00 PM				02:00 PM				02:00 PM			
+0 mins.	4	1	2	7	1	5	0	6	8	16	4	28	4	6	7	17
+15 mins.	1	3	0	4	2	14	3	19	9	16	7	32	1	8	5	14
+30 mins.	4	7	1	12	2	14	1	17	5	6	2	13	7	10	13	30
+45 mins.	2	6	0	8	3	4	2	9	3	8	6	17	4	5	9	18
Total Volume	11	17	3	31	8	37	6	51	25	46	19	90	16	29	34	79
% App. Total	35.5	54.8	9.7		15.7	72.5	11.8		27.8	51.1	21.1		20.3	36.7	43	
PHF	.688	.607	.375	.646	.667	.661	.500	.671	.694	.719	.679	.703	.571	.725	.654	.658

01 ~ } o ÁM |ã ä a Q&E
 UUÁO cAFI I
 ÔI () aZOOAG I i
 QI FDG i E G I

Ôã Á -Sj } * Á^ã@
 BDUK P^) !^ ÁQ |ã ÁE^) ^
 OBY KOF a@a q ÁUd^^c
 Y ^ã@:KÁ } } ^

Qã Áã ^ KSOOP.OE-T Ô
 Úã ÁO[á^ KEEEEEE F
 ÚãOÁã^ KGGJDEFG
 Úã ÁÁ[K&

Groups Printed- Passenger Vehicles - Bobtail Trucks - Chasis Only Trucks - Container Trucks - Other Trucks

Start Time	Henry Ford Avenue Southbound				Anaheim Street Westbound				Henry Ford Avenue Northbound				Anaheim Street Eastbound				Int. Total
	Left	Thru	Right	App. Total	Left	Thru	Right	App. Total	Left	Thru	Right	App. Total	Left	Thru	Right	App. Total	
01:00 PM	25	25	6	56	14	140	28	182	11	9	14	34	22	153	21	196	468
01:15 PM	21	19	16	56	11	164	30	205	25	20	16	61	26	144	22	192	514
01:30 PM	24	17	14	55	17	123	20	160	22	35	18	75	11	176	26	213	503
01:45 PM	25	24	7	56	12	129	31	172	32	28	21	81	26	156	22	204	513
Total	95	85	43	223	54	556	109	719	90	92	69	251	85	629	91	805	1998
02:00 PM	41	19	14	74	11	132	27	170	32	31	28	91	23	150	26	199	534
02:15 PM	22	26	13	61	19	166	25	210	31	33	35	99	19	178	22	219	589
02:30 PM	28	25	21	74	14	167	42	223	25	23	22	70	22	192	34	248	615
02:45 PM	35	37	10	82	18	153	26	197	28	21	22	71	26	174	35	235	585
Total	126	107	58	291	62	618	120	800	116	108	107	331	90	694	117	901	2323
Grand Total	221	192	101	514	116	1174	229	1519	206	200	176	582	175	1323	208	1706	4321
Approch %	43	37.4	19.6		7.6	77.3	15.1		35.4	34.4	30.2		10.3	77.5	12.2		
Total %	5.1	4.4	2.3	11.9	2.7	27.2	5.3	35.2	4.8	4.6	4.1	13.5	4	30.6	4.8	39.5	
Passenger Vehicles	169	58	94	321	90	979	167	1236	92	46	111	249	116	1110	108	1334	3140
% Passenger Vehicles	76.5	30.2	93.1	62.5	77.6	83.4	72.9	81.4	44.7	23	63.1	42.8	66.3	83.9	51.9	78.2	72.7
Bobtail Trucks	20	41	5	66	11	58	17	86	55	85	35	175	25	60	53	138	465
% Bobtail Trucks	9	21.4	5	12.8	9.5	4.9	7.4	5.7	26.7	42.5	19.9	30.1	14.3	4.5	25.5	8.1	10.8
Chasis Only Trucks	0	0	0	0	0	0	0	0	0	0	0	0	0	0	0	0	0
% Chasis Only Trucks	0	0	0	0	0	0	0	0	0	0	0	0	0	0	0	0	0
Container Trucks	25	88	1	114	12	58	23	93	51	62	23	136	23	80	37	140	483
% Container Trucks	11.3	45.8	1	22.2	10.3	4.9	10	6.1	24.8	31	13.1	23.4	13.1	6	17.8	8.2	11.2
Other Trucks	7	5	1	13	3	79	22	104	8	7	7	22	11	73	10	94	233
% Other Trucks	3.2	2.6	1	2.5	2.6	6.7	9.6	6.8	3.9	3.5	4	3.8	6.3	5.5	4.8	5.5	5.4

Start Time	Henry Ford Avenue Southbound				Anaheim Street Westbound				Henry Ford Avenue Northbound				Anaheim Street Eastbound				Int. Total
	Left	Thru	Right	App. Total	Left	Thru	Right	App. Total	Left	Thru	Right	App. Total	Left	Thru	Right	App. Total	
Peak Hour Analysis From 01:00 PM to 02:45 PM - Peak 1 of 1																	
Peak Hour for Entire Intersection Begins at 02:00 PM																	
02:00 PM	41	19	14	74	11	132	27	170	32	31	28	91	23	150	26	199	534
02:15 PM	22	26	13	61	19	166	25	210	31	33	35	99	19	178	22	219	589
02:30 PM	28	25	21	74	14	167	42	223	25	23	22	70	22	192	34	248	615
02:45 PM	35	37	10	82	18	153	26	197	28	21	22	71	26	174	35	235	585
Total Volume	126	107	58	291	62	618	120	800	116	108	107	331	90	694	117	901	2323
% App. Total	43.3	36.8	19.9		7.8	77.2	15		35	32.6	32.3		10	77	13		
PHF	.768	.723	.690	.887	.816	.925	.714	.897	.906	.818	.764	.836	.865	.904	.836	.908	.944

0[~}oAM|ãããQ&E
 UUÁQcÁFII
 Ô[!|}ããÖÖÁGii
 QIFDGiEgi

Ôã Á -Á[]*Á^ãã@
 ÞEUIK^)^!^ÁQ|ãÁE^)^^
 ÖEY KÖEãã@ã ÁUd^^c
 Y^ãã@:KÁU^}}^

ÖE^Áãã ^ KÖÖPÖE-T Ö
 ÚãÁÖ[ã^ KÖÖÖÖÖ F
 ÚããÖãã^ KÖÖJDEFG
 Úãã^Á[KÖ

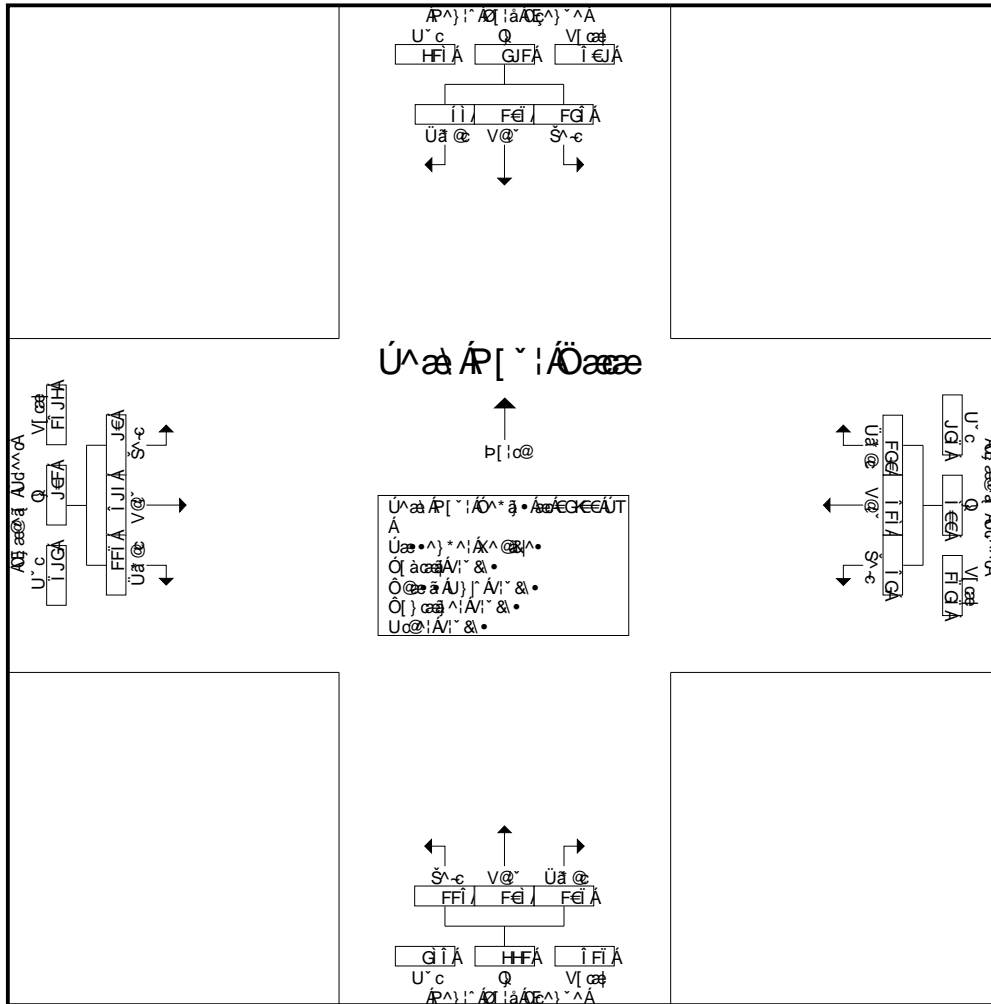

Úãã ÁP[~!ÁÖããæ • ÁÁÖ[! ÁEÖÖÖÁÜT ÁEÖKÍ ÁÜT ÁÜ^ãã ÁEÁ-ÁE
 Peak Hour for Each Approach Begins at:

	02:00 PM				02:00 PM				01:30 PM				02:00 PM			
+0 mins.	41	19	14	74	11	132	27	170	22	35	18	75	23	150	26	199
+15 mins.	22	26	13	61	19	166	25	210	32	28	21	81	19	178	22	219
+30 mins.	28	25	21	74	14	167	42	223	32	31	28	91	22	192	34	248
+45 mins.	35	37	10	82	18	153	26	197	31	33	35	99	26	174	35	235
Total Volume	126	107	58	291	62	618	120	800	117	127	102	346	90	694	117	901
% App. Total	43.3	36.8	19.9		7.8	77.2	15		33.8	36.7	29.5		10	77	13	
PHF	.768	.723	.690	.887	.816	.925	.714	.897	.914	.907	.729	.874	.865	.904	.836	.908

01 ~ } 0 AM | a a a Q & E
 UU A O c A F I I
 O I () a z O O A G I I
 Q I F D G i E G I

O a r A - S j } * A ^ a s @
 P B U K P ^ } ! ^ A Q | a A C E ^ } ^ ^
 O E Y K O E a s @ a A U d ^ ^ c
 Y ^ a s @ : K U } } ^

O a r A a s ^ K S O O P O E T O
 U a r A O j a ^ K E E E E E F
 U a s o A a e ^ K G B J D E F G
 U a s ^ A p [K F

Groups Printed- Passenger Vehicles

Start Time	Henry Ford Avenue Southbound				Anaheim Street Westbound				Henry Ford Avenue Northbound				Anaheim Street Eastbound				Int. Total
	Left	Thru	Right	App. Total	Left	Thru	Right	App. Total	Left	Thru	Right	App. Total	Left	Thru	Right	App. Total	
01:00 PM	21	8	5	34	13	125	22	160	8	2	7	17	18	125	16	159	370
01:15 PM	17	7	16	40	11	139	21	171	15	8	7	30	18	130	15	163	404
01:30 PM	20	4	14	38	16	105	15	136	6	7	13	26	7	135	16	158	358
01:45 PM	20	8	6	34	10	108	22	140	14	5	12	31	17	131	6	154	359
Total	78	27	41	146	50	477	80	607	43	22	39	104	60	521	53	634	1491
02:00 PM	30	9	11	50	9	105	26	140	15	8	22	45	15	125	15	155	390
02:15 PM	19	8	13	40	11	135	12	158	12	11	25	48	14	151	14	179	425
02:30 PM	23	7	19	49	8	132	26	166	11	3	15	29	11	162	13	186	430
02:45 PM	19	7	10	36	12	130	23	165	11	2	10	23	16	151	13	180	404
Total	91	31	53	175	40	502	87	629	49	24	72	145	56	589	55	700	1649
Grand Total	169	58	94	321	90	979	167	1236	92	46	111	249	116	1110	108	1334	3140
Apprch %	52.6	18.1	29.3		7.3	79.2	13.5		36.9	18.5	44.6		8.7	83.2	8.1		
Total %	5.4	1.8	3	10.2	2.9	31.2	5.3	39.4	2.9	1.5	3.5	7.9	3.7	35.4	3.4	42.5	

Start Time	Henry Ford Avenue Southbound				Anaheim Street Westbound				Henry Ford Avenue Northbound				Anaheim Street Eastbound				Int. Total
	Left	Thru	Right	App. Total	Left	Thru	Right	App. Total	Left	Thru	Right	App. Total	Left	Thru	Right	App. Total	
02:00 PM	30	9	11	50	9	105	26	140	15	8	22	45	15	125	15	155	390
02:15 PM	19	8	13	40	11	135	12	158	12	11	25	48	14	151	14	179	425
02:30 PM	23	7	19	49	8	132	26	166	11	3	15	29	11	162	13	186	430
02:45 PM	19	7	10	36	12	130	23	165	11	2	10	23	16	151	13	180	404
Total Volume	91	31	53	175	40	502	87	629	49	24	72	145	56	589	55	700	1649
% App. Total	52	17.7	30.3		6.4	79.8	13.8		33.8	16.6	49.7		8	84.1	7.9		
PHF	.758	.861	.697	.875	.833	.930	.837	.947	.817	.545	.720	.755	.875	.909	.917	.941	.959

Peak Hour Analysis From 02:00 PM to 02:45 PM - Peak 1 of 1

Peak Hour for Entire Intersection Begins at 02:00 PM

0[^ } o AM | a a a Q & E
 UU A Q c A F I I
 0 [| |] a a 0 0 A G I I
 Q I F D G I E G I

0 a r A - A [] * A ^ a s @
 P E U J K P ^) : ^ A Q | a A E ^) ^ ^
 O E Y K A Q F a s @ a A U d ^ ^ c
 Y ^ a s @ : K A U } } ^

0 a r A a s ^ K S O O P O E T O
 U a r A O [a ^ K E E E E E E F
 U a s o A a s ^ K G E J H D E F G
 U a s ^ A r [K G

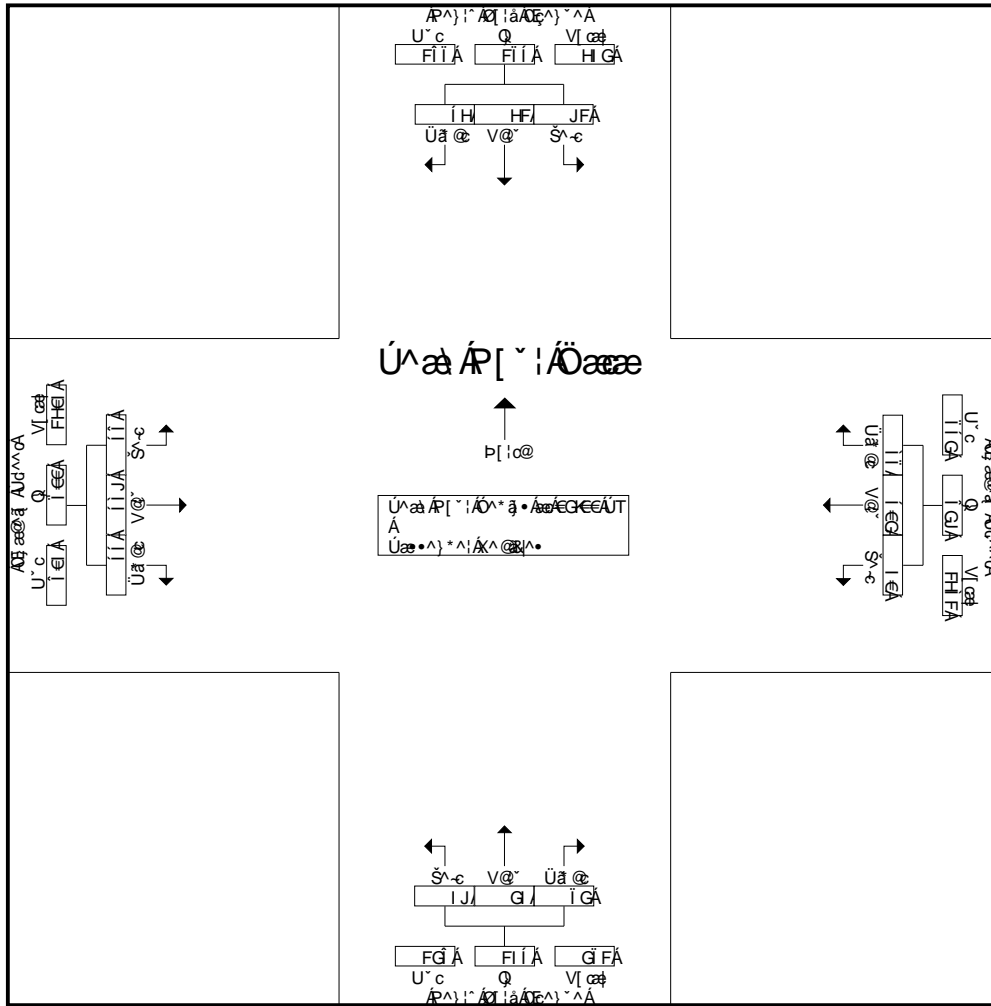

U a s A r [^ | A O a s e • a A O [{ A E G E E A U T A E G K I A U T A U U a s A A - A
 Peak Hour for Each Approach Begins at:

	02:00 PM				02:00 PM				02:00 PM				02:00 PM			
+0 mins.	30	9	11	50	9	105	26	140	15	8	22	45	15	125	15	155
+15 mins.	19	8	13	40	11	135	12	158	12	11	25	48	14	151	14	179
+30 mins.	23	7	19	49	8	132	26	166	11	3	15	29	11	162	13	186
+45 mins.	19	7	10	36	12	130	23	165	11	2	10	23	16	151	13	180
Total Volume	91	31	53	175	40	502	87	629	49	24	72	145	56	589	55	700
% App. Total	52	17.7	30.3		6.4	79.8	13.8		33.8	16.6	49.7		8	84.1	7.9	
PHF	.758	.861	.697	.875	.833	.930	.837	.947	.817	.545	.720	.755	.875	.909	.917	.941

01:00 AM to 01:45 PM
 UUAO cAFI i
 01:15 to 01:45
 QI FDG i E G i

01:00 AM to 01:45 PM
 01:15 PM to 01:45 PM
 01:30 PM to 01:45 PM
 01:45 PM to 01:45 PM

01:00 AM to 01:45 PM
 01:15 PM to 01:45 PM
 01:30 PM to 01:45 PM
 01:45 PM to 01:45 PM

Groups Printed- Chasis Only Trucks

Start Time	Henry Ford Avenue Southbound				Anaheim Street Westbound				Henry Ford Avenue Northbound				Anaheim Street Eastbound				Int. Total
	Left	Thru	Right	App. Total	Left	Thru	Right	App. Total	Left	Thru	Right	App. Total	Left	Thru	Right	App. Total	
01:00 PM	0	0	0	0	0	0	0	0	0	0	0	0	0	0	0	0	0
01:15 PM	0	0	0	0	0	0	0	0	0	0	0	0	0	0	0	0	0
01:30 PM	0	0	0	0	0	0	0	0	0	0	0	0	0	0	0	0	0
01:45 PM	0	0	0	0	0	0	0	0	0	0	0	0	0	0	0	0	0
Total	0	0	0	0	0	0	0	0	0	0	0	0	0	0	0	0	0
02:00 PM	0	0	0	0	0	0	0	0	0	0	0	0	0	0	0	0	0
02:15 PM	0	0	0	0	0	0	0	0	0	0	0	0	0	0	0	0	0
02:30 PM	0	0	0	0	0	0	0	0	0	0	0	0	0	0	0	0	0
02:45 PM	0	0	0	0	0	0	0	0	0	0	0	0	0	0	0	0	0
Total	0	0	0	0	0	0	0	0	0	0	0	0	0	0	0	0	0
Grand Total	0	0	0	0	0	0	0	0	0	0	0	0	0	0	0	0	0
Approch %	0	0	0		0	0	0		0	0	0		0	0	0		
Total %																	

Start Time	Henry Ford Avenue Southbound				Anaheim Street Westbound				Henry Ford Avenue Northbound				Anaheim Street Eastbound				Int. Total
	Left	Thru	Right	App. Total	Left	Thru	Right	App. Total	Left	Thru	Right	App. Total	Left	Thru	Right	App. Total	
02:00 PM	0	0	0	0	0	0	0	0	0	0	0	0	0	0	0	0	0
02:15 PM	0	0	0	0	0	0	0	0	0	0	0	0	0	0	0	0	0
02:30 PM	0	0	0	0	0	0	0	0	0	0	0	0	0	0	0	0	0
02:45 PM	0	0	0	0	0	0	0	0	0	0	0	0	0	0	0	0	0
Total Volume	0	0	0	0	0	0	0	0	0	0	0	0	0	0	0	0	0
% App. Total	0	0	0		0	0	0		0	0	0		0	0	0		
PHF	.000	.000	.000	.000	.000	.000	.000	.000	.000	.000	.000	.000	.000	.000	.000	.000	.000

Peak Hour Analysis From 02:00 PM to 02:45 PM - Peak 1 of 1

Peak Hour for Entire Intersection Begins at 02:00 PM

0[^ } 0 AM | a a a Q & E
 UU A Q c A F F I I
 0 [: [] a a 0 0 A U G I I
 Q I F D G I E G I

0 a r A - S [] * A ^ a s @
 P B U I K P ^) : ^ A Q | a A Q E ^) ^ ^
 O E Y K A Q E a s @ a A U d ^ ^ c
 Y ^ a s @ : K A U ^ } } ^

0 a r A a s ^ K S O O P O E T O
 U a r A O [a ^ K E E E E E F
 U a s o A a s ^ K G E U H D E F G
 U a s ^ A r [K G

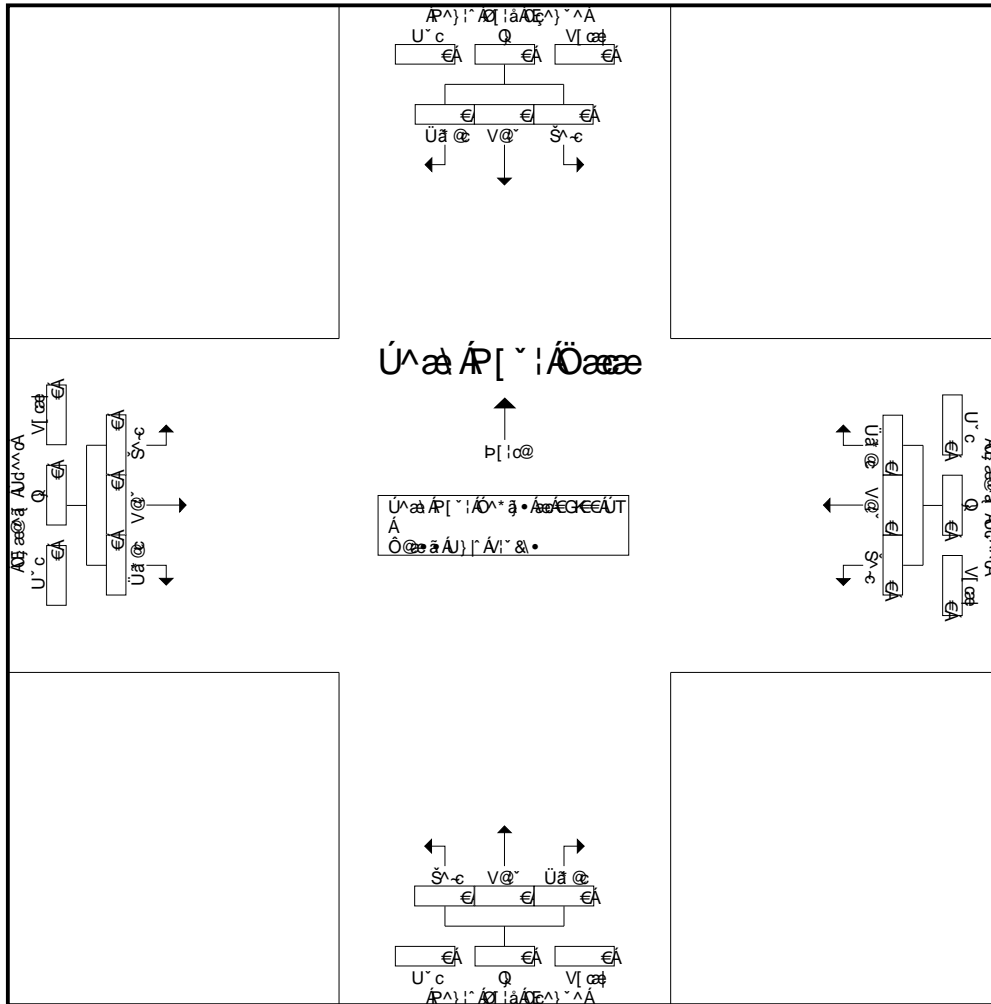

U a r A r ^ : A Q a s ^ a A Q [{ A G E E A U T A A E G K I A U T A A U a s A A - A
 Peak Hour for Each Approach Begins at:

	02:00 PM				02:00 PM				02:00 PM				02:00 PM			
+0 mins.	0	0	0	0	0	0	0	0	0	0	0	0	0	0	0	0
+15 mins.	0	0	0	0	0	0	0	0	0	0	0	0	0	0	0	0
+30 mins.	0	0	0	0	0	0	0	0	0	0	0	0	0	0	0	0
+45 mins.	0	0	0	0	0	0	0	0	0	0	0	0	0	0	0	0
Total Volume	0	0	0	0	0	0	0	0	0	0	0	0	0	0	0	0
% App. Total	0	0	0	0	0	0	0	0	0	0	0	0	0	0	0	0
PHF	.000	.000	.000	.000	.000	.000	.000	.000	.000	.000	.000	.000	.000	.000	.000	.000

Q[~}oÁM|ãããQ&E
 UUÁO cAFI I
 ÔI{)ãZOOAG I i
 QI FDG i E G I

Ôã Á -Sj } * Á^ã&@
 PBUK P^} !^ ÁQ |ãÁE^} ^ ^
 OBY KOF æ@ã ÁUd^^c
 Y ^æ@:KÁ } } ^

Qã Áã ^ KSOOP.OE T Ô
 Úã ÁO[á^ KEEEEEE F
 ÚãóÁæ^ KGBJDEFG
 Úæ^Áp[K&

Groups Printed- Container Trucks

Start Time	Henry Ford Avenue Southbound				Anaheim Street Westbound				Henry Ford Avenue Northbound				Anaheim Street Eastbound				Int. Total
	Left	Thru	Right	App. Total	Left	Thru	Right	App. Total	Left	Thru	Right	App. Total	Left	Thru	Right	App. Total	
01:00 PM	1	10	0	11	0	3	2	5	1	2	6	9	4	8	2	14	39
01:15 PM	1	8	0	9	0	9	3	12	2	4	2	8	2	4	3	9	38
01:30 PM	2	5	0	7	0	4	2	6	3	12	1	16	2	15	4	21	50
01:45 PM	1	9	0	10	1	6	0	7	6	8	4	18	3	12	7	22	57
Total	5	32	0	37	1	22	7	30	12	26	13	51	11	39	16	66	184
02:00 PM	4	8	0	12	1	10	1	12	8	7	2	17	2	12	4	18	59
02:15 PM	2	15	0	17	3	6	6	15	10	6	2	18	3	10	2	15	65
02:30 PM	1	11	1	13	4	9	8	21	9	13	4	26	2	10	6	18	78
02:45 PM	13	22	0	35	3	11	1	15	12	10	2	24	5	9	9	23	97
Total	20	56	1	77	11	36	16	63	39	36	10	85	12	41	21	74	299
Grand Total	25	88	1	114	12	58	23	93	51	62	23	136	23	80	37	140	483
Apprch %	21.9	77.2	0.9		12.9	62.4	24.7		37.5	45.6	16.9		16.4	57.1	26.4		
Total %	5.2	18.2	0.2	23.6	2.5	12	4.8	19.3	10.6	12.8	4.8	28.2	4.8	16.6	7.7	29	

Start Time	Henry Ford Avenue Southbound				Anaheim Street Westbound				Henry Ford Avenue Northbound				Anaheim Street Eastbound				Int. Total
	Left	Thru	Right	App. Total	Left	Thru	Right	App. Total	Left	Thru	Right	App. Total	Left	Thru	Right	App. Total	
02:00 PM	4	8	0	12	1	10	1	12	8	7	2	17	2	12	4	18	59
02:15 PM	2	15	0	17	3	6	6	15	10	6	2	18	3	10	2	15	65
02:30 PM	1	11	1	13	4	9	8	21	9	13	4	26	2	10	6	18	78
02:45 PM	13	22	0	35	3	11	1	15	12	10	2	24	5	9	9	23	97
Total Volume	20	56	1	77	11	36	16	63	39	36	10	85	12	41	21	74	299
% App. Total	26	72.7	1.3		17.5	57.1	25.4		45.9	42.4	11.8		16.2	55.4	28.4		
PHF	.385	.636	.250	.550	.688	.818	.500	.750	.813	.692	.625	.817	.600	.854	.583	.804	.771

Peak Hour Analysis From 02:00 PM to 02:45 PM - Peak 1 of 1

Peak Hour for Entire Intersection Begins at 02:00 PM

0[~ } 0 AM | a a a Q & E
 UU A Q c A F I I
 0[! !] a a 0 0 A G I I
 Q I F D G I E G I

0 a r A - A [] * A O a s @
 P E U I K P ^) ! ^ A Q | a A C E ^) ^ ^
 O E Y K O E a s @ a A U d ^ ^ c
 Y ^ a s @ : K A U } } ^

0 a r A a s ^ K S O O P O E T O
 U a r A O [a ^ K E E E E E E F
 U a s o A a s ^ K G E U H D E F G
 U a s ^ A r [K G

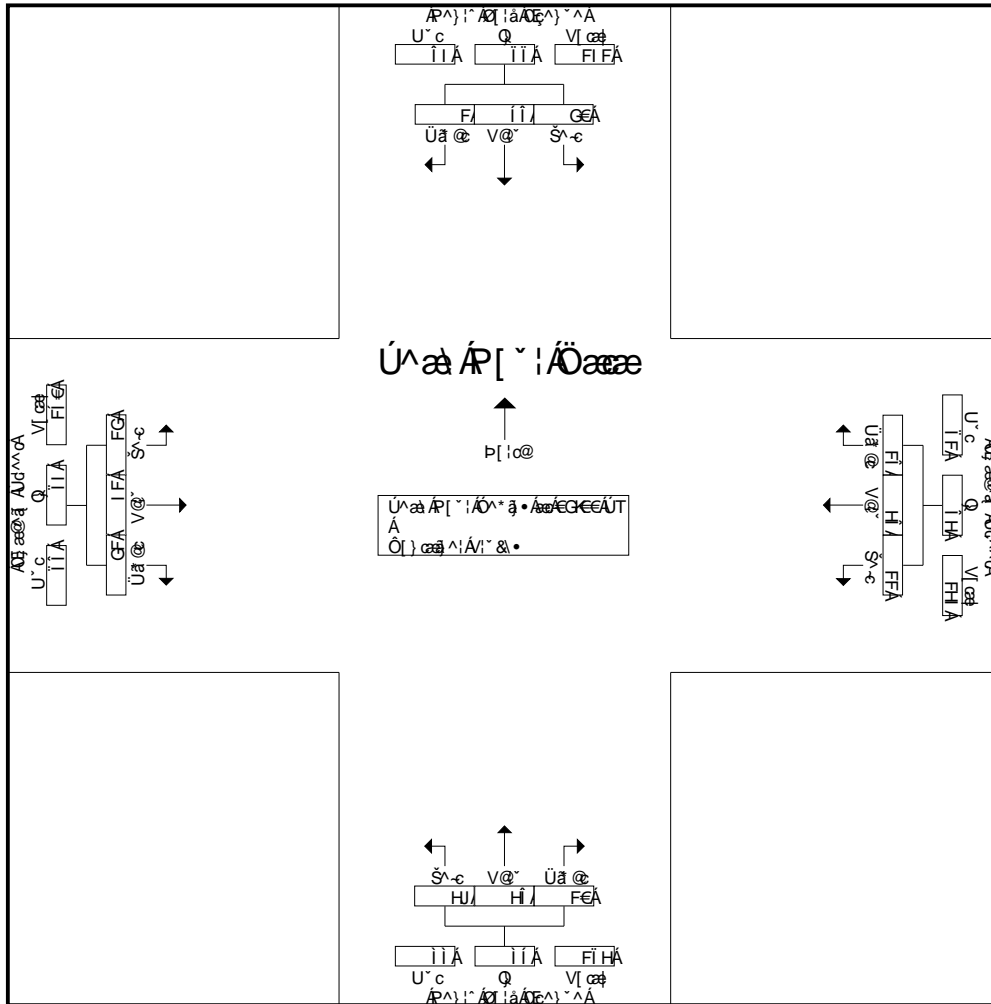

U a s A r [~ ! A O a s e • a A O [{ A E G E A U T A E G K I A U T A A U a s A A - A
 Peak Hour for Each Approach Begins at:

	02:00 PM				02:00 PM				02:00 PM				02:00 PM			
+0 mins.	4	8	0	12	1	10	1	12	8	7	2	17	2	12	4	18
+15 mins.	2	15	0	17	3	6	6	15	10	6	2	18	3	10	2	15
+30 mins.	1	11	1	13	4	9	8	21	9	13	4	26	2	10	6	18
+45 mins.	13	22	0	35	3	11	1	15	12	10	2	24	5	9	9	23
Total Volume	20	56	1	77	11	36	16	63	39	36	10	85	12	41	21	74
% App. Total	26	72.7	1.3		17.5	57.1	25.4		45.9	42.4	11.8		16.2	55.4	28.4	
PHF	.385	.636	.250	.550	.688	.818	.500	.750	.813	.692	.625	.817	.600	.854	.583	.804

01:00 AM
 01:15 AM
 01:30 AM
 01:45 AM

02:00 PM
 02:15 PM
 02:30 PM
 02:45 PM

03:00 PM
 03:15 PM
 03:30 PM
 03:45 PM

Groups Printed- Other Trucks

Start Time	Henry Ford Avenue Southbound				Anaheim Street Westbound				Henry Ford Avenue Northbound				Anaheim Street Eastbound				Int. Total
	Left	Thru	Right	App. Total	Left	Thru	Right	App. Total	Left	Thru	Right	App. Total	Left	Thru	Right	App. Total	
01:00 PM	0	2	0	2	0	8	2	10	0	0	0	0	0	11	0	11	23
01:15 PM	1	0	0	1	0	13	3	16	1	1	0	2	2	7	0	9	28
01:30 PM	1	0	0	1	0	9	1	10	3	1	0	4	1	14	2	17	32
01:45 PM	1	0	0	1	0	6	5	11	1	3	1	5	2	6	1	9	26
Total	3	2	0	5	0	36	11	47	5	5	1	11	5	38	3	46	109
02:00 PM	3	1	1	5	0	12	0	12	1	0	0	1	2	7	0	9	27
02:15 PM	0	0	0	0	3	11	4	18	0	0	1	1	1	9	1	11	30
02:30 PM	0	0	0	0	0	12	7	19	0	1	1	2	2	10	2	14	35
02:45 PM	1	2	0	3	0	8	0	8	2	1	4	7	1	9	4	14	32
Total	4	3	1	8	3	43	11	57	3	2	6	11	6	35	7	48	124
Grand Total	7	5	1	13	3	79	22	104	8	7	7	22	11	73	10	94	233
Apprch %	53.8	38.5	7.7		2.9	76	21.2		36.4	31.8	31.8		11.7	77.7	10.6		
Total %	3	2.1	0.4	5.6	1.3	33.9	9.4	44.6	3.4	3	3	9.4	4.7	31.3	4.3	40.3	

Start Time	Henry Ford Avenue Southbound				Anaheim Street Westbound				Henry Ford Avenue Northbound				Anaheim Street Eastbound				Int. Total
	Left	Thru	Right	App. Total	Left	Thru	Right	App. Total	Left	Thru	Right	App. Total	Left	Thru	Right	App. Total	
02:00 PM	3	1	1	5	0	12	0	12	1	0	0	1	2	7	0	9	27
02:15 PM	0	0	0	0	3	11	4	18	0	0	1	1	1	9	1	11	30
02:30 PM	0	0	0	0	0	12	7	19	0	1	1	2	2	10	2	14	35
02:45 PM	1	2	0	3	0	8	0	8	2	1	4	7	1	9	4	14	32
Total Volume	4	3	1	8	3	43	11	57	3	2	6	11	6	35	7	48	124
% App. Total	50	37.5	12.5		5.3	75.4	19.3		27.3	18.2	54.5		12.5	72.9	14.6		
PHF	.333	.375	.250	.400	.250	.896	.393	.750	.375	.500	.375	.393	.750	.875	.438	.857	.886

Peak Hour Analysis From 02:00 PM to 02:45 PM - Peak 1 of 1

Peak Hour for Entire Intersection Begins at 02:00 PM

0[^ } 0 AM | a a a Q & E
 UU A Q c A F I I
 0 [| |] a a 0 0 A G I I
 Q I F D G I E G I

0 a t A - A [] * A ^ a s @
 P E U I K P ^) ! ^ A Q | a A E ^) ^ ^
 O E Y K A Q E a s @ a A U d ^ ^ c
 Y ^ a s @ : K A U } } ^

0 a t A a s ^ K S O O P O E T O
 U a t A O [a ^ K E E E E E F
 U a s o A a s ^ K G E U H E F G
 U a s ^ A [K G

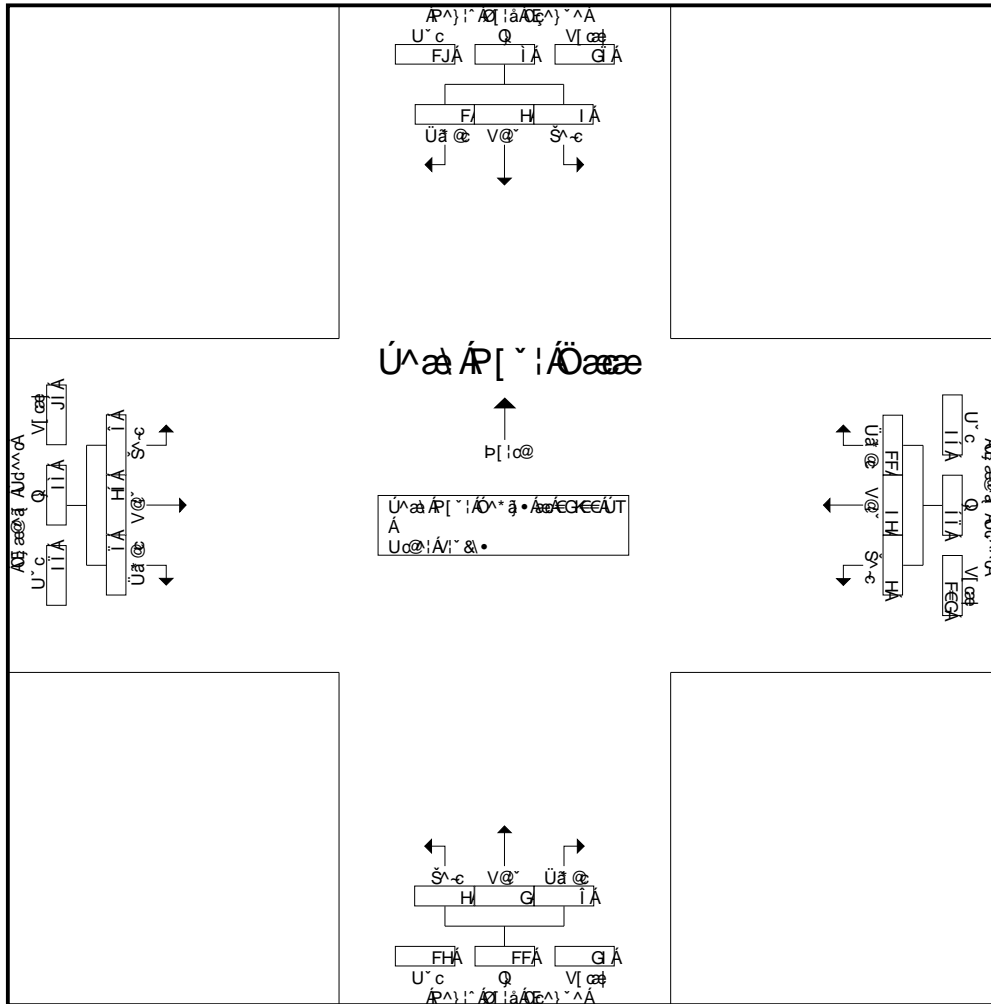

U a s A P [^ | A O a s e • a A O [{ A E G E A U T A E G K I A U T A A U ^ a A A - A
 Peak Hour for Each Approach Begins at:

	02:00 PM				02:00 PM				02:00 PM				02:00 PM			
+0 mins.	3	1	1	5	0	12	0	12	1	0	0	1	2	7	0	9
+15 mins.	0	0	0	0	3	11	4	18	0	0	1	1	1	9	1	11
+30 mins.	0	0	0	0	0	12	7	19	0	1	1	2	2	10	2	14
+45 mins.	1	2	0	3	0	8	0	8	2	1	4	7	1	9	4	14
Total Volume	4	3	1	8	3	43	11	57	3	2	6	11	6	35	7	48
% App. Total	50	37.5	12.5		5.3	75.4	19.3		27.3	18.2	54.5		12.5	72.9	14.6	
PHF	.333	.375	.250	.400	.250	.896	.393	.750	.375	.500	.375	.393	.750	.875	.438	.857

01 ~ } o ÁM |ã ä á ÁQ&E
 UUÁO cÁFI I
 Ô | () aÉOÖÁG I i
 QI FDG i È G I

Ôã Á -Sj } * ÁOã@
 BDUK P ^) : ^ ÁQ |ã ÁE ^) ^ ^
 ÔEY KÖE ä@ ä ÁUd^^c
 Y ^ ä@ : KÁU } } ^

ÔE Á ä ^ KÖÓP ÖE ÚT
 Úã ÁO | ä ^ KÉÉÉÉÉ F
 Úã ö Ö ä ^ KÖEJ BDEFG
 Úã ^ Á | KÉ

Groups Printed- Passenger Vehicles - Bobtail Trucks - Chasis Only Trucks - Container Trucks - Other Trucks

Start Time	Henry Ford Avenue Southbound				Anaheim Street Westbound				Henry Ford Avenue Northbound				Anaheim Street Eastbound				Int. Total
	Left	Thru	Right	App. Total	Left	Thru	Right	App. Total	Left	Thru	Right	App. Total	Left	Thru	Right	App. Total	
04:00 PM	33	40	5	78	9	180	29	218	49	46	25	120	23	243	32	298	714
04:15 PM	38	38	7	83	10	199	31	240	54	36	20	110	20	240	36	296	729
04:30 PM	34	31	9	74	12	217	42	271	49	24	14	87	22	259	35	316	748
04:45 PM	34	39	5	78	8	190	27	225	44	25	23	92	22	292	72	386	781
Total	139	148	26	313	39	786	129	954	196	131	82	409	87	1034	175	1296	2972
05:00 PM	55	39	8	102	21	166	35	222	22	13	20	55	21	316	76	413	792
05:15 PM	41	43	10	94	7	139	18	164	21	6	15	42	23	267	60	350	650
05:30 PM	29	33	11	73	6	127	24	157	14	14	12	40	18	218	39	275	545
05:45 PM	34	28	7	69	4	102	14	120	16	9	7	32	16	168	25	209	430
Total	159	143	36	338	38	534	91	663	73	42	54	169	78	969	200	1247	2417
Grand Total	298	291	62	651	77	1320	220	1617	269	173	136	578	165	2003	375	2543	5389
Apprch %	45.8	44.7	9.5		4.8	81.6	13.6		46.5	29.9	23.5		6.5	78.8	14.7		
Total %	5.5	5.4	1.2	12.1	1.4	24.5	4.1	30	5	3.2	2.5	10.7	3.1	37.2	7	47.2	
Passenger Vehicles	242	69	50	361	51	1181	166	1398	160	70	102	332	120	1867	255	2242	4333
% Passenger Vehicles	81.2	23.7	80.6	55.5	66.2	89.5	75.5	86.5	59.5	40.5	75	57.4	72.7	93.2	68	88.2	80.4
Bobtail Trucks	29	99	7	135	12	69	32	113	60	50	18	128	21	35	71	127	503
% Bobtail Trucks	9.7	34	11.3	20.7	15.6	5.2	14.5	7	22.3	28.9	13.2	22.1	12.7	1.7	18.9	5	9.3
Chasis Only Trucks	0	0	0	0	0	0	2	2	0	0	0	0	0	0	0	0	2
% Chasis Only Trucks	0	0	0	0	0	0	0.9	0.1	0	0	0	0	0	0	0	0	0
Container Trucks	20	120	5	145	11	37	12	60	45	50	13	108	18	58	44	120	433
% Container Trucks	6.7	41.2	8.1	22.3	14.3	2.8	5.5	3.7	16.7	28.9	9.6	18.7	10.9	2.9	11.7	4.7	8
Other Trucks	7	3	0	10	3	33	8	44	4	3	3	10	6	43	5	54	118
% Other Trucks	2.3	1	0	1.5	3.9	2.5	3.6	2.7	1.5	1.7	2.2	1.7	3.6	2.1	1.3	2.1	2.2

Start Time	Henry Ford Avenue Southbound				Anaheim Street Westbound				Henry Ford Avenue Northbound				Anaheim Street Eastbound				Int. Total
	Left	Thru	Right	App. Total	Left	Thru	Right	App. Total	Left	Thru	Right	App. Total	Left	Thru	Right	App. Total	
Peak Hour Analysis From 04:00 PM to 05:45 PM - Peak 1 of 1																	
Peak Hour for Entire Intersection Begins at 04:15 PM																	
04:15 PM	38	38	7	83	10	199	31	240	54	36	20	110	20	240	36	296	729
04:30 PM	34	31	9	74	12	217	42	271	49	24	14	87	22	259	35	316	748
04:45 PM	34	39	5	78	8	190	27	225	44	25	23	92	22	292	72	386	781
05:00 PM	55	39	8	102	21	166	35	222	22	13	20	55	21	316	76	413	792
Total Volume	161	147	29	337	51	772	135	958	169	98	77	344	85	1107	219	1411	3050
% App. Total	47.8	43.6	8.6		5.3	80.6	14.1		49.1	28.5	22.4		6	78.5	15.5		
PHF	.732	.942	.806	.826	.607	.889	.804	.884	.782	.681	.837	.782	.966	.876	.720	.854	.963

0[~ } , 0 AM | a a a Q & E
 U U A Q c A F F I I
 0 [! !] a a Q O A G I I
 Q I F D G I E G I

0 a r A - A [] * A O a s @
 P E U J K P A) ! " A Q | a A E A) ^ ^
 O E Y K O E a s @ a A U d ^ ^ c
 Y ^ a s @ : K A U " } } ^

0 E A P a s ^ K S O O P O E U T
 U a r A O [a ^ K E E E E E F
 U a s c O a s ^ K C R J B E F G
 U a s ^ A P [K G

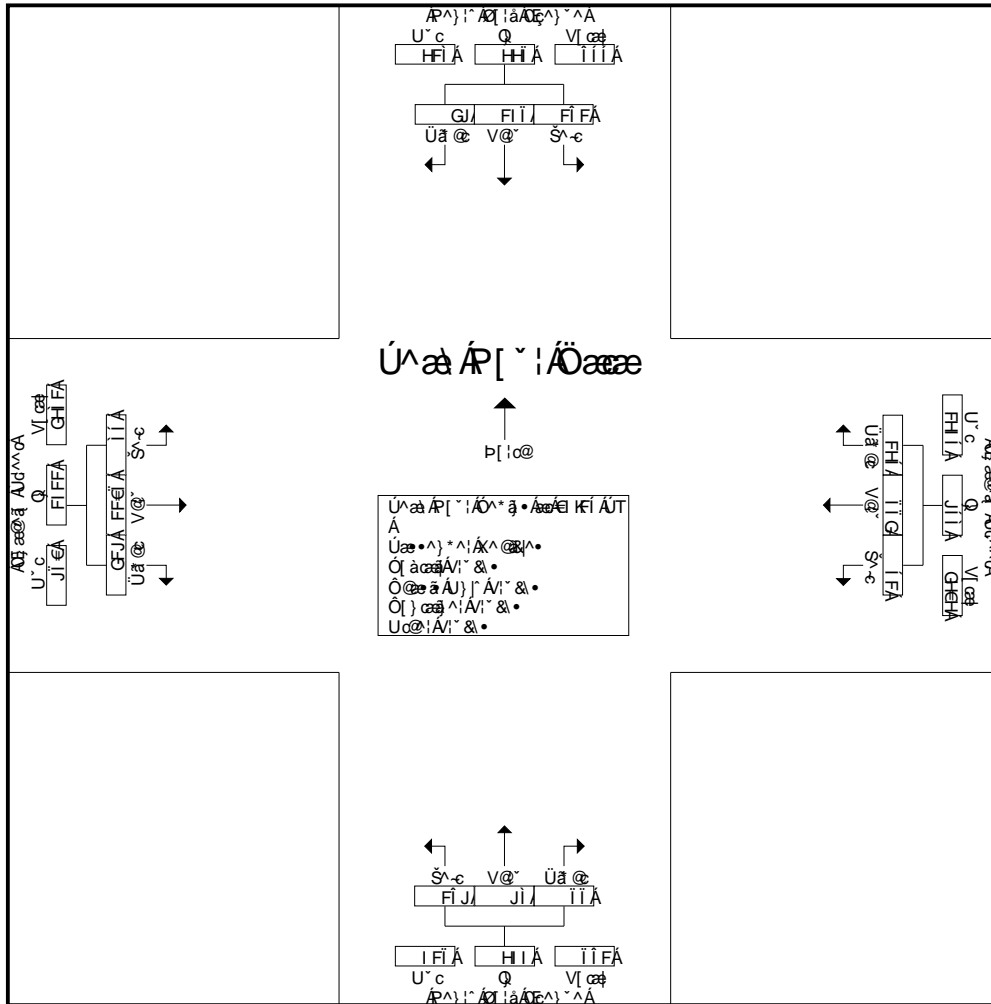

U^aa AP[~ ! A O a s e a A O [{ A E K E U T A E A E K I A U T A U ^ a s A A - A
 Peak Hour for Each Approach Begins at:

	04:30 PM				04:15 PM				04:00 PM				04:30 PM			
+0 mins.	34	31	9	74	10	199	31	240	49	46	25	120	22	259	35	316
+15 mins.	34	39	5	78	12	217	42	271	54	36	20	110	22	292	72	386
+30 mins.	55	39	8	102	8	190	27	225	49	24	14	87	21	316	76	413
+45 mins.	41	43	10	94	21	166	35	222	44	25	23	92	23	267	60	350
Total Volume	164	152	32	348	51	772	135	958	196	131	82	409	88	1134	243	1465
% App. Total	47.1	43.7	9.2		5.3	80.6	14.1		47.9	32	20		6	77.4	16.6	
PHF	.745	.884	.800	.853	.607	.889	.804	.884	.907	.712	.820	.852	.957	.897	.799	.887

01 ~ } o ÁM |ã ä á ÁQ&E
 UUÁO cÁFI I
 ÔI () äÖÖÁG I i
 QI FDG i È G I

Ôã Á -Sj } * Á^ã&@
 PBUK P ^ } ! ^ ÁQ |ã ÁQ E ^ } ^
 OBY KÖE ä@ ä ÁUd^^c
 Y ^ ä@ :KÜ } } ^

QY Á pã ^ KÖÖP ÖE ÚT
 Úã ÁO [ä ^ KÖÖÖÖÖ F
 Úã ö Ö ä ^ KÖÖ Ö Ö F G
 Úã ^ Á [KÖ

Groups Printed- Passenger Vehicles

Start Time	Henry Ford Avenue Southbound				Anaheim Street Westbound				Henry Ford Avenue Northbound				Anaheim Street Eastbound				Int. Total
	Left	Thru	Right	App. Total	Left	Thru	Right	App. Total	Left	Thru	Right	App. Total	Left	Thru	Right	App. Total	
04:00 PM	26	12	5	43	7	157	16	180	23	10	14	47	15	224	20	259	529
04:15 PM	33	10	7	50	4	171	21	196	27	11	10	48	14	221	24	259	553
04:30 PM	32	11	9	52	8	185	36	229	27	5	9	41	12	238	18	268	590
04:45 PM	26	9	5	40	5	168	21	194	33	18	21	72	17	272	66	355	661
Total	117	42	26	185	24	681	94	799	110	44	54	208	58	955	128	1141	2333
05:00 PM	46	7	6	59	16	153	26	195	16	9	16	41	20	297	60	377	672
05:15 PM	29	7	4	40	4	131	15	150	14	4	15	33	21	250	31	302	525
05:30 PM	25	8	8	41	4	121	19	144	10	9	12	31	12	208	23	243	459
05:45 PM	25	5	6	36	3	95	12	110	10	4	5	19	9	157	13	179	344
Total	125	27	24	176	27	500	72	599	50	26	48	124	62	912	127	1101	2000
Grand Total	242	69	50	361	51	1181	166	1398	160	70	102	332	120	1867	255	2242	4333
Apprch %	67	19.1	13.9		3.6	84.5	11.9		48.2	21.1	30.7		5.4	83.3	11.4		
Total %	5.6	1.6	1.2	8.3	1.2	27.3	3.8	32.3	3.7	1.6	2.4	7.7	2.8	43.1	5.9	51.7	

Start Time	Henry Ford Avenue Southbound				Anaheim Street Westbound				Henry Ford Avenue Northbound				Anaheim Street Eastbound				Int. Total
	Left	Thru	Right	App. Total	Left	Thru	Right	App. Total	Left	Thru	Right	App. Total	Left	Thru	Right	App. Total	
04:15 PM	33	10	7	50	4	171	21	196	27	11	10	48	14	221	24	259	553
04:30 PM	32	11	9	52	8	185	36	229	27	5	9	41	12	238	18	268	590
04:45 PM	26	9	5	40	5	168	21	194	33	18	21	72	17	272	66	355	661
05:00 PM	46	7	6	59	16	153	26	195	16	9	16	41	20	297	60	377	672
Total Volume	137	37	27	201	33	677	104	814	103	43	56	202	63	1028	168	1259	2476
% App. Total	68.2	18.4	13.4		4.1	83.2	12.8		51	21.3	27.7		5	81.7	13.3		
PHF	.745	.841	.750	.852	.516	.915	.722	.889	.780	.597	.667	.701	.788	.865	.636	.835	.921

Peak Hour Analysis From 04:15 PM to 05:00 PM - Peak 1 of 1

Peak Hour for Entire Intersection Begins at 04:15 PM

0[^ } o AM | a a a Q & E
 UU A Q c A F I I
 0 [| | } a a Q A G I i
 Q I F D G i E d i

0 a r A - S [] * A O a s @
 P B U J K P ^) ! ^ A Q | a A E ^) ^ ^
 O E Y K A Q E a s @ a A U d ^ ^ c
 Y ^ a s @ : K A U } } ^

0 E ^ A p a s ^ K S O P Q E U T
 U a r A O [a ^ K E E E E E F
 U c a s c O a s ^ K C R J B E F G
 U a s ^ A p [K G

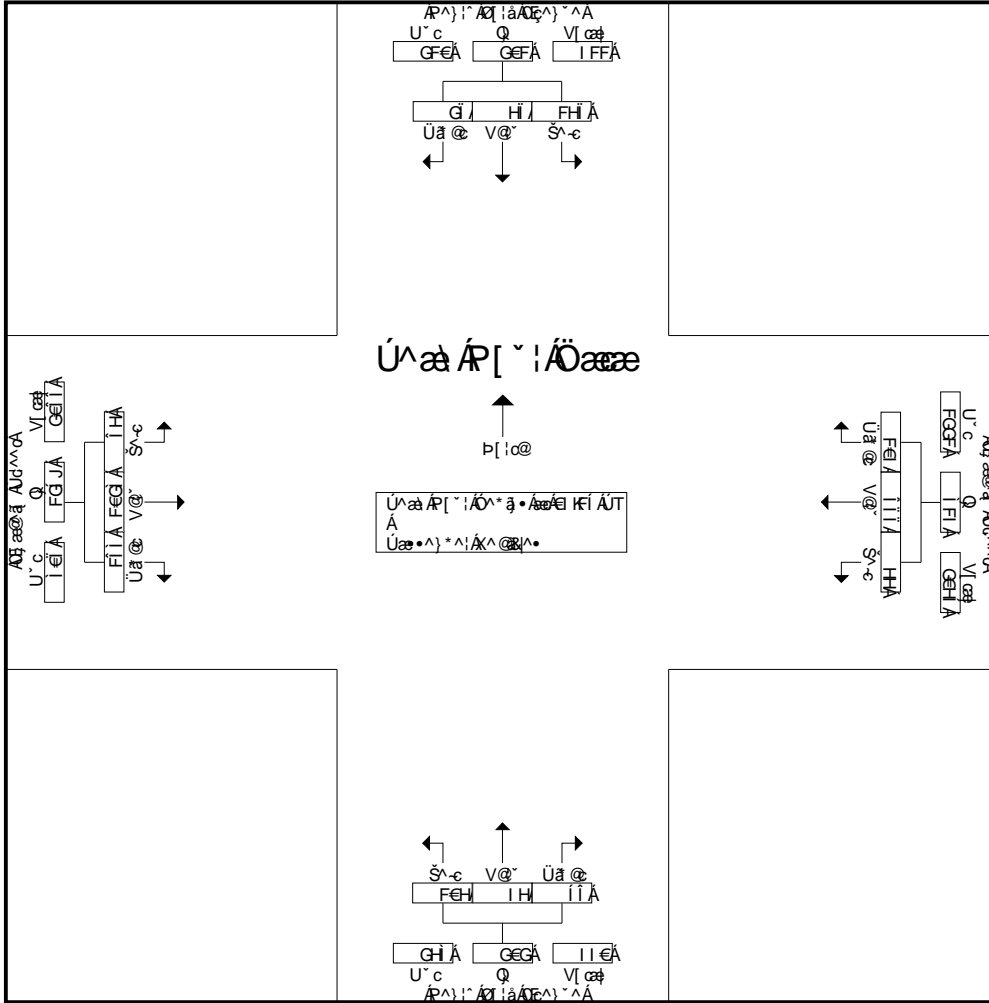

U a s A R [^ | A O a s e * a A O [{ A e K F I A U T A e A i K E A U T A A U a s A A - A
 Peak Hour for Each Approach Begins at:

	04:15 PM				04:15 PM				04:15 PM				04:15 PM			
+0 mins.	33	10	7	50	4	171	21	196	27	11	10	48	14	221	24	259
+15 mins.	32	11	9	52	8	185	36	229	27	5	9	41	12	238	18	268
+30 mins.	26	9	5	40	5	168	21	194	33	18	21	72	17	272	66	355
+45 mins.	46	7	6	59	16	153	26	195	16	9	16	41	20	297	60	377
Total Volume	137	37	27	201	33	677	104	814	103	43	56	202	63	1028	168	1259
% App. Total	68.2	18.4	13.4		4.1	83.2	12.8		51	21.3	27.7		5	81.7	13.3	
PHF	.745	.841	.750	.852	.516	.915	.722	.889	.780	.597	.667	.701	.788	.865	.636	.835

01 ~ } o ÁM |ã ä^áQ&E
 UUÁO cÁFI I
 ÔI() aZOOÁG I i
 QI FDG i È G I

Ôã Á -S() * Á^as@
 PBUK P ^) : ^ ÁQ |ãÁE ^) ^
 OBY KOF as@ ä ÁUd^^c
 Y ^ as@ :KÁ } } ^

QY^ P as ^ KSOOP.OCÉ ÚT
 Úã ÁO[ä^ KCCCCÉ F
 Úã áOã^ KCBJ DEFG
 Úã ^ ÁP[K^

Groups Printed- Bobtail Trucks

Start Time	Henry Ford Avenue Southbound				Anaheim Street Westbound				Henry Ford Avenue Northbound				Anaheim Street Eastbound				Int. Total
	Left	Thru	Right	App. Total	Left	Thru	Right	App. Total	Left	Thru	Right	App. Total	Left	Thru	Right	App. Total	
04:00 PM	3	10	0	13	0	10	8	18	14	16	6	36	3	4	6	13	80
04:15 PM	2	6	0	8	4	12	7	23	10	16	3	29	2	4	8	14	74
04:30 PM	2	12	0	14	2	20	3	25	13	7	5	25	8	5	5	18	82
04:45 PM	6	14	0	20	2	11	3	16	10	3	1	14	3	2	2	7	57
Total	13	42	0	55	8	53	21	82	47	42	15	104	16	15	21	52	293
05:00 PM	5	18	1	24	3	6	5	14	2	2	3	7	0	7	6	13	58
05:15 PM	8	20	4	32	0	4	2	6	4	2	0	6	2	7	19	28	72
05:30 PM	2	10	2	14	1	2	3	6	4	3	0	7	1	2	13	16	43
05:45 PM	1	9	0	10	0	4	1	5	3	1	0	4	2	4	12	18	37
Total	16	57	7	80	4	16	11	31	13	8	3	24	5	20	50	75	210
Grand Total	29	99	7	135	12	69	32	113	60	50	18	128	21	35	71	127	503
Apprch %	21.5	73.3	5.2		10.6	61.1	28.3		46.9	39.1	14.1		16.5	27.6	55.9		
Total %	5.8	19.7	1.4	26.8	2.4	13.7	6.4	22.5	11.9	9.9	3.6	25.4	4.2	7	14.1	25.2	

Start Time	Henry Ford Avenue Southbound				Anaheim Street Westbound				Henry Ford Avenue Northbound				Anaheim Street Eastbound				Int. Total
	Left	Thru	Right	App. Total	Left	Thru	Right	App. Total	Left	Thru	Right	App. Total	Left	Thru	Right	App. Total	
04:15 PM	2	6	0	8	4	12	7	23	10	16	3	29	2	4	8	14	74
04:30 PM	2	12	0	14	2	20	3	25	13	7	5	25	8	5	5	18	82
04:45 PM	6	14	0	20	2	11	3	16	10	3	1	14	3	2	2	7	57
05:00 PM	5	18	1	24	3	6	5	14	2	2	3	7	0	7	6	13	58
Total Volume	15	50	1	66	11	49	18	78	35	28	12	75	13	18	21	52	271
% App. Total	22.7	75.8	1.5		14.1	62.8	23.1		46.7	37.3	16		25	34.6	40.4		
PHF	.625	.694	.250	.688	.688	.613	.643	.780	.673	.438	.600	.647	.406	.643	.656	.722	.826

Peak Hour Analysis From 04:15 PM to 05:00 PM - Peak 1 of 1

Peak Hour for Entire Intersection Begins at 04:15 PM

0[^ } o AM | a a a Q & E
 UU A O c A F F I I
 O [! |] a a O O A G I I
 Q I F D G I E G I

O a r A - S [] * A O a s @
 P E U J K P ^) ! " A Q | a A E ^) ^
 O E Y K O F a s @ a A U d ^ ^ c
 Y ^ a s @ : K A U " } } ^

O E ^ A p a s ^ K S O O P O E U T
 U a r A O [a ^ K E E E E E F
 U c a s O a s ^ K C B J B E F G
 U a s ^ A p [K G

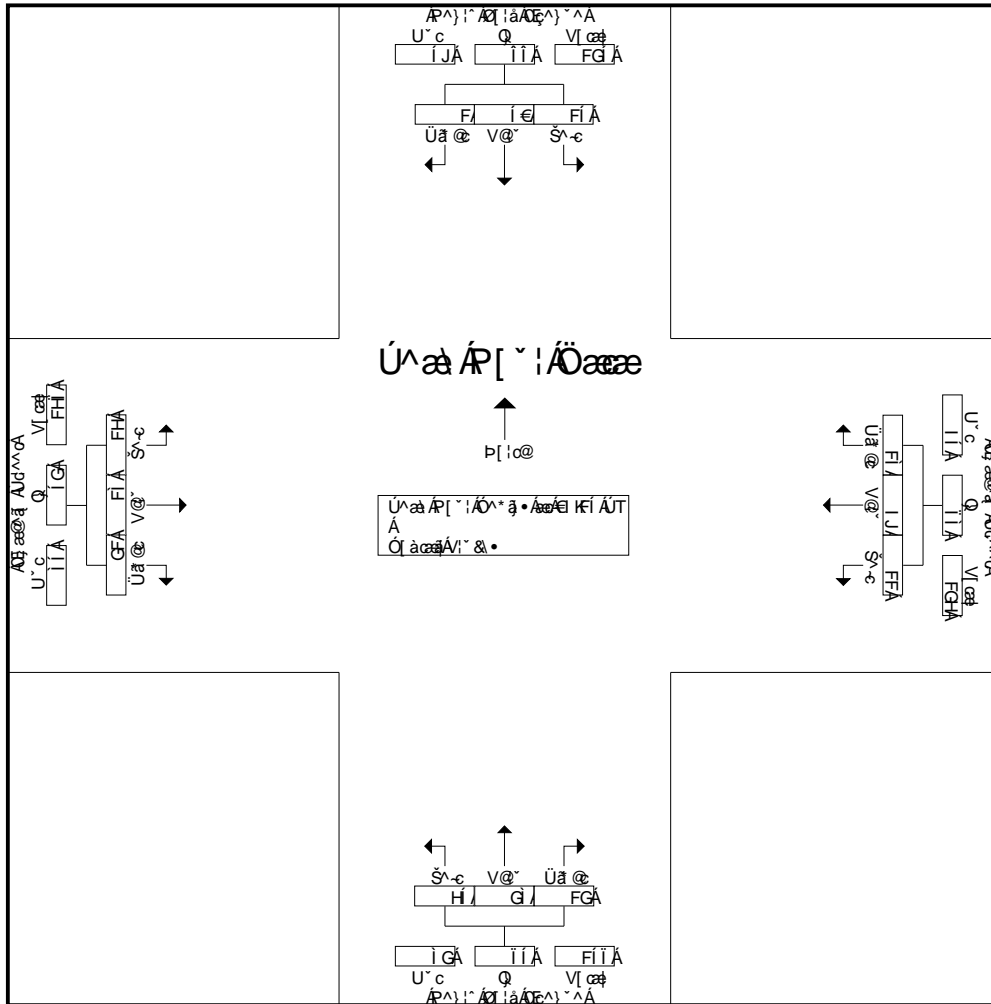

U a s A p [^ ! A O a s @ a A O [{ A E K F I A U T A E A I K E A U T A A U a s A A - A
 Peak Hour for Each Approach Begins at:

	04:15 PM				04:15 PM				04:15 PM				04:15 PM			
+0 mins.	2	6	0	8	4	12	7	23	10	16	3	29	2	4	8	14
+15 mins.	2	12	0	14	2	20	3	25	13	7	5	25	8	5	5	18
+30 mins.	6	14	0	20	2	11	3	16	10	3	1	14	3	2	2	7
+45 mins.	5	18	1	24	3	6	5	14	2	2	3	7	0	7	6	13
Total Volume	15	50	1	66	11	49	18	78	35	28	12	75	13	18	21	52
% App. Total	22.7	75.8	1.5		14.1	62.8	23.1		46.7	37.3	16		25	34.6	40.4	
PHF	.625	.694	.250	.688	.688	.613	.643	.780	.673	.438	.600	.647	.406	.643	.656	.722

01 ~ } o AM | a a a Q & E
 UU A O c A F I i
 O i () a 2 0 0 A G i i
 Q I F D G i E G i

O a A - S () * A ^ a s @
 P B U J K P ^) : ^ A Q | a A C E ^) ^ ^
 O E Y K O E a s @ a A U d ^ ^ c
 Y ^ a s @ : K U } } ^

O E ^ A a s ^ K S O O P O C E U T
 U a A O [a ^ K C E C C C E F
 U a s O a s ^ K C B J B E F G
 U a s ^ A [K F

Groups Printed- Chasis Only Trucks

Start Time	Henry Ford Avenue Southbound				Anaheim Street Westbound				Henry Ford Avenue Northbound				Anaheim Street Eastbound				Int. Total
	Left	Thru	Right	App. Total	Left	Thru	Right	App. Total	Left	Thru	Right	App. Total	Left	Thru	Right	App. Total	
04:00 PM	0	0	0	0	0	0	2	2	0	0	0	0	0	0	0	0	2
04:15 PM	0	0	0	0	0	0	0	0	0	0	0	0	0	0	0	0	0
04:30 PM	0	0	0	0	0	0	0	0	0	0	0	0	0	0	0	0	0
04:45 PM	0	0	0	0	0	0	0	0	0	0	0	0	0	0	0	0	0
Total	0	0	0	0	0	0	2	2	0	0	0	0	0	0	0	0	2
05:00 PM	0	0	0	0	0	0	0	0	0	0	0	0	0	0	0	0	0
05:15 PM	0	0	0	0	0	0	0	0	0	0	0	0	0	0	0	0	0
05:30 PM	0	0	0	0	0	0	0	0	0	0	0	0	0	0	0	0	0
05:45 PM	0	0	0	0	0	0	0	0	0	0	0	0	0	0	0	0	0
Total	0	0	0	0	0	0	0	0	0	0	0	0	0	0	0	0	0
Grand Total	0	0	0	0	0	0	2	2	0	0	0	0	0	0	0	0	2
Approch %	0	0	0		0	0	100		0	0	0		0	0	0		
Total %	0	0	0		0	0	100	100	0	0	0		0	0	0		

Start Time	Henry Ford Avenue Southbound				Anaheim Street Westbound				Henry Ford Avenue Northbound				Anaheim Street Eastbound				Int. Total
	Left	Thru	Right	App. Total	Left	Thru	Right	App. Total	Left	Thru	Right	App. Total	Left	Thru	Right	App. Total	
04:15 PM	0	0	0	0	0	0	0	0	0	0	0	0	0	0	0	0	0
04:30 PM	0	0	0	0	0	0	0	0	0	0	0	0	0	0	0	0	0
04:45 PM	0	0	0	0	0	0	0	0	0	0	0	0	0	0	0	0	0
05:00 PM	0	0	0	0	0	0	0	0	0	0	0	0	0	0	0	0	0
Total Volume	0	0	0	0	0	0	0	0	0	0	0	0	0	0	0	0	0
% App. Total	0	0	0		0	0	0		0	0	0		0	0	0		
PHF	.000	.000	.000	.000	.000	.000	.000	.000	.000	.000	.000	.000	.000	.000	.000	.000	.000

Peak Hour Analysis From 04:15 PM to 05:00 PM - Peak 1 of 1

Peak Hour for Entire Intersection Begins at 04:15 PM

0[^ } . 0 AM | a a a Q & E
 UU A Q c A F I I
 0 [: [] a a 0 0 A G I i
 Q I F D G i E d i

0 a r A - A [] * A ^ a s @
 P E U J K P ^) : ^ A Q | a A C E ^) ^ ^
 O E Y K A Q E a s @ a A U d ^ ^ c
 Y ^ a s @ : K A U ^ } } ^

0 E ^ A p a s ^ K S O P Q E U T
 U a r A O [a ^ K E E E E E F
 U a s c O a s ^ K C B J D E F G
 U a s ^ A p [K G

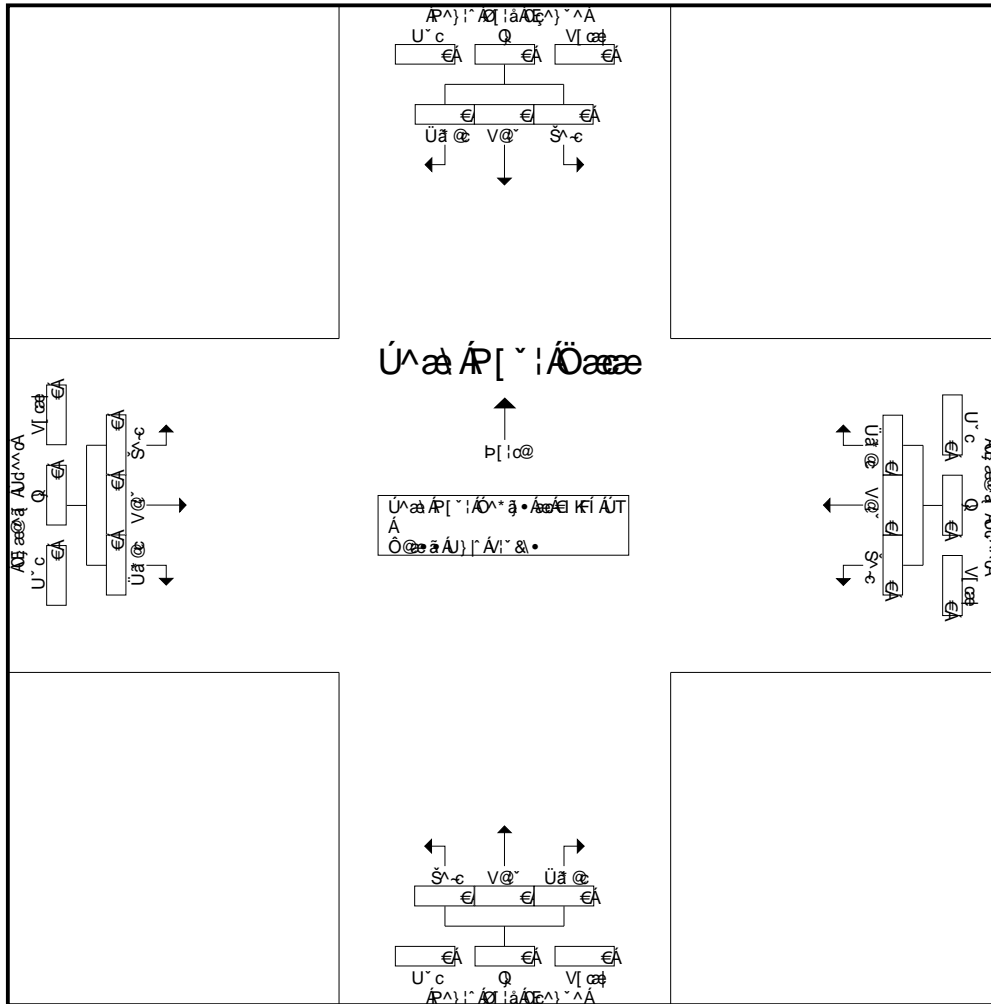

U^c a r A [^ | A O a s e * a A Q [{ A E K I A U T A E A I K E A U T A A U^c a r A - A

Peak Hour for Each Approach Begins at:

	04:15 PM				04:15 PM				04:15 PM				04:15 PM			
+0 mins.	0	0	0	0	0	0	0	0	0	0	0	0	0	0	0	0
+15 mins.	0	0	0	0	0	0	0	0	0	0	0	0	0	0	0	0
+30 mins.	0	0	0	0	0	0	0	0	0	0	0	0	0	0	0	0
+45 mins.	0	0	0	0	0	0	0	0	0	0	0	0	0	0	0	0
Total Volume	0	0	0	0	0	0	0	0	0	0	0	0	0	0	0	0
% App. Total	0	0	0	0	0	0	0	0	0	0	0	0	0	0	0	0
PHF	.000	.000	.000	.000	.000	.000	.000	.000	.000	.000	.000	.000	.000	.000	.000	.000

01 ~ } o ÁM |ã ä á ÁQ&E
 UUÁO cÁFI I
 ÔI () äZOOÁG I i
 QI FDG i È G i

Ôã Á -Sj } * Á^ã&@
 PBUK P ^ } ! ^ ÁQ |ã ÁQ E ^ } ^
 OBY KQF ä@ ä ÁUd^^c
 Y ^ ä@ :KÁ } } ^

QF Á pã ^ KSOOP. QOE ÚT
 Úã ÁO [ä^ KCCCCC F
 Úã c Oã^ KCBJ BDEFG
 Úã ^ Á [K F

Groups Printed- Container Trucks

Start Time	Henry Ford Avenue Southbound				Anaheim Street Westbound				Henry Ford Avenue Northbound				Anaheim Street Eastbound				Int. Total
	Left	Thru	Right	App. Total	Left	Thru	Right	App. Total	Left	Thru	Right	App. Total	Left	Thru	Right	App. Total	
04:00 PM	3	18	0	21	2	4	2	8	11	19	4	34	4	3	5	12	75
04:15 PM	1	21	0	22	2	9	2	13	15	9	7	31	4	10	3	17	83
04:30 PM	0	7	0	7	1	8	2	11	9	11	0	20	1	11	11	23	61
04:45 PM	1	15	0	16	0	5	1	6	1	4	1	6	2	12	4	18	46
Total	5	61	0	66	5	26	7	38	36	43	12	91	11	36	23	70	265
05:00 PM	4	14	1	19	1	6	2	9	4	1	0	5	1	8	10	19	52
05:15 PM	4	16	2	22	3	1	1	5	3	0	0	3	0	4	8	12	42
05:30 PM	1	15	1	17	1	2	2	5	0	2	0	2	2	5	3	10	34
05:45 PM	6	14	1	21	1	2	0	3	2	4	1	7	4	5	0	9	40
Total	15	59	5	79	6	11	5	22	9	7	1	17	7	22	21	50	168
Grand Total	20	120	5	145	11	37	12	60	45	50	13	108	18	58	44	120	433
Apprch %	13.8	82.8	3.4		18.3	61.7	20		41.7	46.3	12		15	48.3	36.7		
Total %	4.6	27.7	1.2	33.5	2.5	8.5	2.8	13.9	10.4	11.5	3	24.9	4.2	13.4	10.2	27.7	

Start Time	Henry Ford Avenue Southbound				Anaheim Street Westbound				Henry Ford Avenue Northbound				Anaheim Street Eastbound				Int. Total
	Left	Thru	Right	App. Total	Left	Thru	Right	App. Total	Left	Thru	Right	App. Total	Left	Thru	Right	App. Total	
04:15 PM	1	21	0	22	2	9	2	13	15	9	7	31	4	10	3	17	83
04:30 PM	0	7	0	7	1	8	2	11	9	11	0	20	1	11	11	23	61
04:45 PM	1	15	0	16	0	5	1	6	1	4	1	6	2	12	4	18	46
05:00 PM	4	14	1	19	1	6	2	9	4	1	0	5	1	8	10	19	52
Total Volume	6	57	1	64	4	28	7	39	29	25	8	62	8	41	28	77	242
% App. Total	9.4	89.1	1.6		10.3	71.8	17.9		46.8	40.3	12.9		10.4	53.2	36.4		
PHF	.375	.679	.250	.727	.500	.778	.875	.750	.483	.568	.286	.500	.500	.854	.636	.837	.729

Peak Hour Analysis From 04:15 PM to 05:00 PM - Peak 1 of 1

Peak Hour for Entire Intersection Begins at 04:15 PM

0[^ } 0 AM | a a a Q & E
 UU A Q c A F I I
 0[| | } a a 0 A G I I
 Q I F D G I E G I

0 a r A - S [] * A O a s @
 P E U J K P ^) ! " A Q | a A C E ^) ^
 O E Y K A Q E a s @ a A U d ^ ^ c
 Y ^ a s @ : K A U " } } ^

0 E ^ A p a s ^ K S O O P O C E U T
 U a r A O [a ^ K E E E E E F
 U a s c O a s ^ K C R J B E F G
 U a s ^ A p [K G

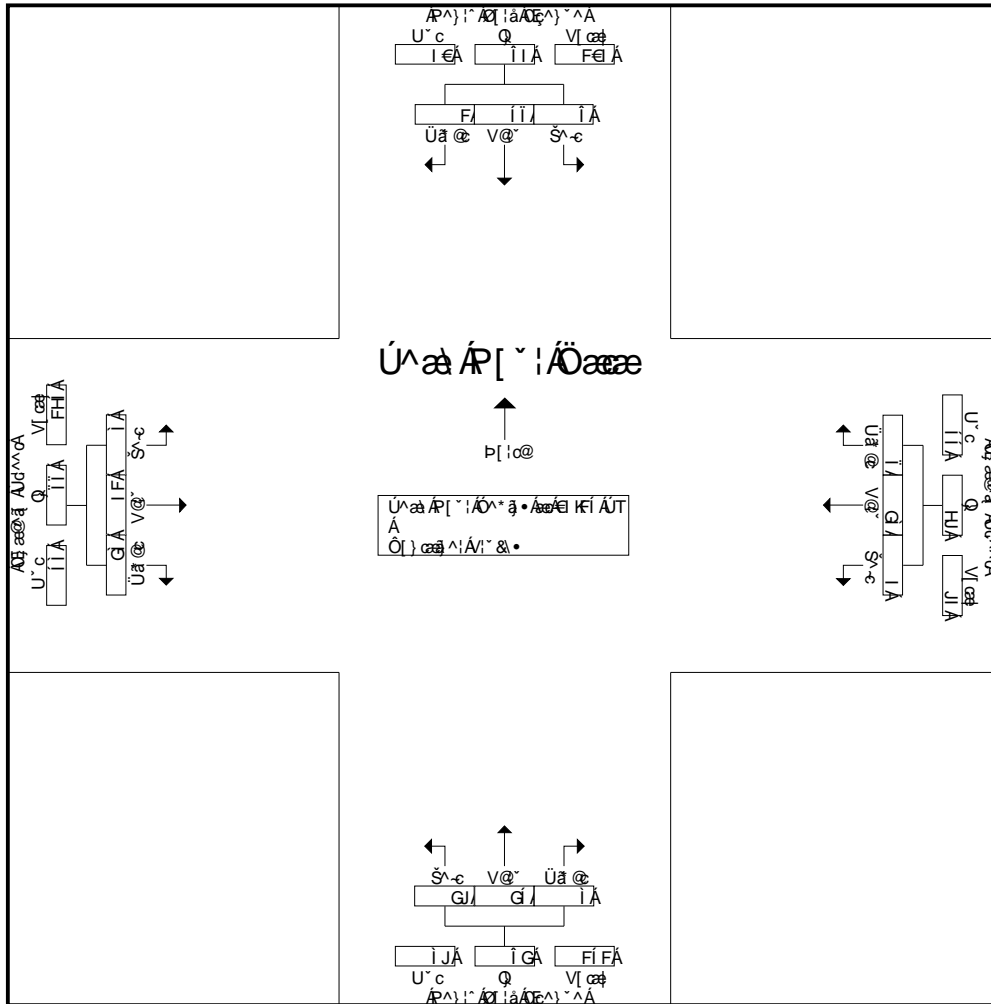

U a s A P [^ | A C E a s ^ a A Q [{ A E K F I A U T A E A I K E A U T A A U a s A A - A
 Peak Hour for Each Approach Begins at:

	04:15 PM				04:15 PM				04:15 PM				04:15 PM			
+0 mins.	1	21	0	22	2	9	2	13	15	9	7	31	4	10	3	17
+15 mins.	0	7	0	7	1	8	2	11	9	11	0	20	1	11	11	23
+30 mins.	1	15	0	16	0	5	1	6	1	4	1	6	2	12	4	18
+45 mins.	4	14	1	19	1	6	2	9	4	1	0	5	1	8	10	19
Total Volume	6	57	1	64	4	28	7	39	29	25	8	62	8	41	28	77
% App. Total	9.4	89.1	1.6		10.3	71.8	17.9		46.8	40.3	12.9		10.4	53.2	36.4	
PHF	.375	.679	.250	.727	.500	.778	.875	.750	.483	.568	.286	.500	.500	.854	.636	.837

01 ~ } 0 AM | a a a Q & E
 UU A O c A F I I
 O I () a z O O A G I I
 Q I F D G I E G I

O a r A - S [] * A ^ a s @
 P B U J K P ^) : ^ A Q | a A C E ^) ^ ^
 O E Y K O E a s @ a A U d ^ ^ c
 Y ^ a s @ : K U } } ^

O E ^ A a s ^ K S O O P O E U T
 U a r A O [a ^ K C E C C E C E F
 U c a s O a e ^ K C B J B E F G
 U a s ^ A p [K F

Groups Printed- Other Trucks

Start Time	Henry Ford Avenue Southbound				Anaheim Street Westbound				Henry Ford Avenue Northbound				Anaheim Street Eastbound				Int. Total
	Left	Thru	Right	App. Total	Left	Thru	Right	App. Total	Left	Thru	Right	App. Total	Left	Thru	Right	App. Total	
04:00 PM	1	0	0	1	0	9	1	10	1	1	1	3	1	12	1	14	28
04:15 PM	2	1	0	3	0	7	1	8	2	0	0	2	0	5	1	6	19
04:30 PM	0	1	0	1	1	4	1	6	0	1	0	1	1	5	1	7	15
04:45 PM	1	1	0	2	1	6	2	9	0	0	0	0	0	6	0	6	17
Total	4	3	0	7	2	26	5	33	3	2	1	6	2	28	3	33	79
05:00 PM	0	0	0	0	1	1	2	4	0	1	1	2	0	4	0	4	10
05:15 PM	0	0	0	0	0	3	0	3	0	0	0	0	0	6	2	8	11
05:30 PM	1	0	0	1	0	2	0	2	0	0	0	0	3	3	0	6	9
05:45 PM	2	0	0	2	0	1	1	2	1	0	1	2	1	2	0	3	9
Total	3	0	0	3	1	7	3	11	1	1	2	4	4	15	2	21	39
Grand Total	7	3	0	10	3	33	8	44	4	3	3	10	6	43	5	54	118
Apprch %	70	30	0		6.8	75	18.2		40	30	30		11.1	79.6	9.3		
Total %	5.9	2.5	0	8.5	2.5	28	6.8	37.3	3.4	2.5	2.5	8.5	5.1	36.4	4.2	45.8	

Start Time	Henry Ford Avenue Southbound				Anaheim Street Westbound				Henry Ford Avenue Northbound				Anaheim Street Eastbound				Int. Total
	Left	Thru	Right	App. Total	Left	Thru	Right	App. Total	Left	Thru	Right	App. Total	Left	Thru	Right	App. Total	
04:15 PM	2	1	0	3	0	7	1	8	2	0	0	2	0	5	1	6	19
04:30 PM	0	1	0	1	1	4	1	6	0	1	0	1	1	5	1	7	15
04:45 PM	1	1	0	2	1	6	2	9	0	0	0	0	0	6	0	6	17
05:00 PM	0	0	0	0	1	1	2	4	0	1	1	2	0	4	0	4	10
Total Volume	3	3	0	6	3	18	6	27	2	2	1	5	1	20	2	23	61
% App. Total	50	50	0		11.1	66.7	22.2		40	40	20		4.3	87	8.7		
PHF	.375	.750	.000	.500	.750	.643	.750	.750	.250	.500	.250	.625	.250	.833	.500	.821	.803

Peak Hour Analysis From 04:15 PM to 05:00 PM - Peak 1 of 1

Peak Hour for Entire Intersection Begins at 04:15 PM

01 ~ } o AM ja a a Q & E
 UU A Q c A F I I
 01 (I) a a O A U G I I
 Q I F D G I E G I

O a r A - S [} * A ^ a s @
 P B U I K P ^) ! ^ A Q i a A C E ^) ^ ^
 O E Y K A Q E a s @ a A U d ^ ^ c
 Y ^ a s @ ! K A U } } ^

Q E ^ A p a s ^ K S O O P O C E U T
 U a r A O i a ^ K E E E E E F
 U c a s c O a e ^ K C B J B E F G
 U a s ^ A p [K G

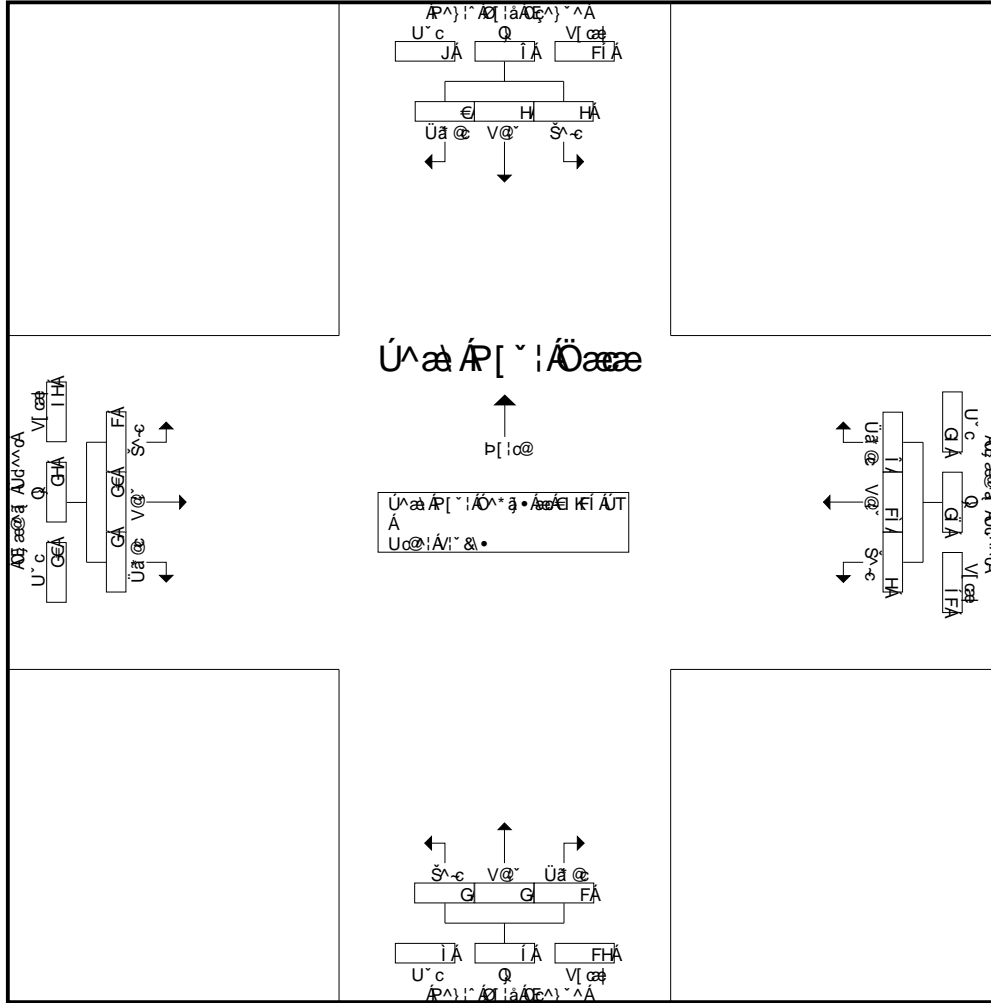

U a r A p [~ ! A C E a s @ a A Q I { A E K I A U T A A I K E A U T A A U ^ a s A A - A
 Peak Hour for Each Approach Begins at:

	04:15 PM				04:15 PM				04:15 PM				04:15 PM			
+0 mins.	2	1	0	3	0	7	1	8	2	0	0	2	0	5	1	6
+15 mins.	0	1	0	1	1	4	1	6	0	1	0	1	1	5	1	7
+30 mins.	1	1	0	2	1	6	2	9	0	0	0	0	0	6	0	6
+45 mins.	0	0	0	0	1	1	2	4	0	1	1	2	0	4	0	4
Total Volume	3	3	0	6	3	18	6	27	2	2	1	5	1	20	2	23
% App. Total	50	50	0		11.1	66.7	22.2		40	40	20		4.3	87	8.7	
PHF	.375	.750	.000	.500	.750	.643	.750	.750	.250	.500	.250	.625	.250	.833	.500	.821

ÚÜËÚÒPÒÓÛÄÒPÖÖSÛ

Ö^Äæ ^KÖÜ: *|æ Ä^æ æææfUJUÖÖÖPÖÖE È] ä

ÚöäÖæ^KÖÜEÖFG

ÚöäÖä ^Kí KEEÖÖE

Úä^Ö| ä^KEEÖÖÖÖE

Ö({ ^) öKÖæ Ä-Ä) * Ä^æ&@

Ö({ ^) öKÖæÄ^): Ä| äÖÜËÈÈÖÜE-HÜÖÜæ] •

Ö({ ^) öKÖEY HÜA:ÖY æ

Ö({ ^) öKY ^æ@:HÜ)} ^

ÚöäÖä ^	P^): Ä äÖE^ ^ Ü ö@ ^) ä				Úä:ÖY æ Y ^• ö@ ^) ä				ÜÜËÈÈÖÜE-HÜÖÜæ] • P ö@ ^) ä				P^): Ä äÖE^ ^ Öæ ö@ ^) ä			
	Š^c	V@^	Üä @	Ü^ä•	Š^c	V@^	Üä @	Ü^ä•	Š^c	V@^	Üä @	Ü^ä•	Š^c	V@^	Üä @	Ü^ä•
È KEEÖE	F€	I	F	€	G	G	F	€	J	I	I	€	F€	€	H	€
È KÍ ÖE	F€	I €	ì	€	F	€	€	€	H	I	FG	€	FG	€	I	€
È KHEÖE	F	I	F€	€	€	G	F	€	í	I	FF	G	H	F	í	F
È KÍ ÖE	F	GH	ì	€	H	€	H	F	G	ì	ì	F	ì	€	F	€
È KEEÖE	ì	FJ	FF	€	í	€	€	€	G	ì	H	F	I	€	G	F
È KÍ ÖE	í	J	FF	€	F	€	€	€	€	Fí	H	F	í	€	H	€
È KHEÖE	í	FG	F€	€	H	€	F	€	í	FH	ì	G	í	F	G	€
È KÍ ÖE	I	FI	F€	€	I	€	€	€	I	FF	í	F	FH	€	I	F

UVPÖÜÄÜWÖSÜ

Ü^Ää ^KÖÜ| "ä Ä^ä ää ääGÜFäUÖÖäÖPÖÖE ä] ä
 ÜäöÖäKÖWÖEFG
 ÜäöÄä ^Kí KEEÄE
 ÜäÄ| ä^KEEEEEE
 Ö({ ^) öKÖä Ä-Ä} * Ä^ä@
 Ö({ ^) öKÖWÖ^: "Ä| äWÜE I EÜE-EÄÜÜä] •
 Ö({ ^) öKÖY HÜÄ:ÄY ä
 Ö({ ^) öKY ^ä@:HÜ} "

ÜäöÄä ^	P^}: "Ä äÄ^ ^ Ü ä@ " ä				Üä:ÄY ä Y ^• ä " ä				ÜÜE I EÜE-EÄÜÜä] • P ä@ " ä				P^}: "Ä äÄ^ ^ Öä ä " ä			
	S^c	V@	Üä @	Ü^ä•	S^c	V@	Üä @	Ü^ä•	S^c	V@	Üä @	Ü^ä•	S^c	V@	Üä @	Ü^ä•
Äí KEEÄE	€	€	€	€	€	€	€	F	í	€	€	€	€	€	€	€
Äí Kí ÄE	€	F	F	€	F	F	€	€	F	€	€	F	F	€	€	€
Äí Kí ÄE	€	F	í	€	€	€	€	€	F	G	€	F	F	F	G	€
Äí Kí ÄE	€	H	€	€	F	F	€	€	€	F	€	F	F	€	€	€
Äí KEEÄE	€	l	€	€	F	€	€	€	€	F	€	€	F	F	H	€
Äí Kí ÄE	€	H	€	€	€	€	€	G	F	F	€	€	€	€	F	€
Äí KEEÄE	F	€	€	€	F	€	€	€	F	G	€	€	€	€	€	€
Äí Kí ÄE	F	F	F	€	F	€	€	F	€	F	€	G	€	F	G	€

ÖÜPVOÖÖÜÜÄÜWÖSÜ

Ö^Ää ^KÖHÜ|":ä Ä^ä ää ääGÜFäUÜSÖäSÖÖPÖÖÖÖ ä
 ÜöäÖäKÖWÖÖÖFG
 ÜöäÖä ^Kí KÖÖÖÖÖÖ
 Üä^Ö|ä^KÖÖÖÖÖÖÖÖÖÖ
 Ö({ (^) öKÖä Ä-Ä) *Ä^äö@
 Ö({ (^) öKÖWÖ^):"Ä| äWÜÖÖ ÖÜÖÖHÜÖÜä]•
 Ö({ (^) öKÖY HÜä:ÖY ä
 Ö({ (^) öKY ^ä@:HÜ)"

ÜöäÖä ^	P^):"Ä ä(Ö^)^ ^ Ü ö@ ^) ä				Üä:ÖY ä Y ^• ö@ ^) ä				ÜÜÖÖ ÖÜÖÖHÜÖÜä]• P ö@ ^) ä				P^):"Ä ä(Ö^)^ ^ Öä ö@ ^) ä			
	S^c	V@	Üä @	Ü^ä•	S^c	V@	Üä @	Ü^ä•	S^c	V@	Üä @	Ü^ä•	S^c	V@	Üä @	Ü^ä•
Öí KÖÖÖÖ	F	F	€	€	€	€	€	F	€	€	€	€	€	€	€	€
Öí Kí ÖÖ	î	î	€	F	€	€	€	€	€	€	€	F	€	€	€	€
Öí Kí ÖÖ	í	FF	€	í	€	€	€	€	€	F	€	F	€	€	€	G
Öí Kí ÖÖ	F	ì	€	€	€	€	€	€	€	F	G	F	€	€	€	€
Öí KÖÖÖÖ	F	J	€	€	€	€	€	€	€	€	F	€	€	€	€	H
Öí Kí ÖÖ	î	FI	€	€	€	€	€	G	€	F	H	€	€	€	€	F
Öí KÖÖÖÖ	í	FF	€	€	€	€	í	€	€	H	€	€	€	€	€	€
Öí Kí ÖÖ	I	J	€	F	€	€	F€	F	€	I	F	G	€	€	€	G

UVPÖÜÄÜWÖSÜ

Ö^Ää ^KÖÜ| *!ä Ä^ä ää ääGÜFäUÖÖÖÖÖÖÖÖÖÖ Ö| ä
 ÜöäÖä^KÖWÖÖFG
 ÜöäÖä ^KFÖÖÖÖÖÖÖÖÖÖ
 ÜäÄ| ä^KÖÖÖÖÖÖÖÖÖÖ
 Ö({ ^) öKÖä Ä-Ä} *Ä^ä@
 Ö({ ^) öKÖWÖ^ ä! Ä| äÄÜÜ| ÄÜÜ| äHÜÖÜä] •
 Ö({ ^) öKÖY HÜä! ÖY ä
 Ö({ ^) öKY ^ä@! HÜ } ^

ÜöäÖä ^	P^)! Ä äÄ^ ^ Ü ä@ ^ ä				Üä! ÖY ä Y ^• ä ^ ä				ÜÜÜ ÜÜÜ äHÜÖÜä] • P ä@ ^ ä				P^)! Ä äÄ^ ^ Öä ä ^ ä			
	S^c	V@	Üä @	Ü^ä•	S^c	V@	Üä @	Ü^ä•	S^c	V@	Üä @	Ü^ä•	S^c	V@	Üä @	Ü^ä•
€FÖÖÜT	G	H	G	€	H	€	€	€	G	G	€	€	F	F	G	€
€FKÖÜT	F	€	€	€	€	€	F	€	F	€	G	€	G	€	G	€
€FKÖÜT	€	G	F	€	€	F	G	€	F	H	G	€	F	€	F	€
€FKÖÜT	F	€	€	€	F	€	F	€	F	F	€	€	€	€	F	€
€GÖÖÜT	€	H	€	€	€	€	€	€	€	G	F	€	H	€	€	€
€GÖÜT	€	G	F	€	H	€	€	€	€	F	€	€	G	€	G	€
€GKÖÜT	€	€	G	€	H	€	F	€	G	G	€	€	€	€	G	€
€GKÖÜT	€	F	€	€	F	€	€	€	F	H	€	€	G	€	F	€

ÓÙ Þ VÖÐ ÖÜÁÜWÖSÜ

Ö^Áæ ^KÖÁÜ| *|æ ÁÖ^ææ ææfGÚFáUUSÖæSÖÖPÖÖÖ ÖË] á

ÜæðÖæ^KGÖWÖEFG

ÜæðÁä ^KFKEEÄÜT

Üæ^ÁÖ| á^KEEEEEEF

Ö({ (^) öfKÖæ Á-Ä) * ÁÖæ&@

Ö({ (^) öGÞÖWÖ^) á: Ä| íáÜÜË| ÁÜËE-HÜÖÜæ] •

Ö({ (^) öKÖBY HÜá: ÖY æ

Ö({ (^) öKY ^æ@: HÜ} } ^

ÜæðÁä ^	P^} : Ä íáÖE^)^ ^ Ü ^ö@ ^} á				Üá: ÖY æ Y ^• ö@ ^} á				ÜÜË ÖÜËE-HÜÖÜæ] • P íö@ ^} á				P^} : Ä íáÖE^)^ ^ Öæ ö@ ^} á			
	S^-c	V@^	Üä @	Ü^á•	S^-c	V@^	Üä @	Ü^á•	S^-c	V@^	Üä @	Ü^á•	S^-c	V@^	Üä @	Ü^á•
€FKÉÁÜT	í	í	€	€	€	€	í	€	€	G	G	€	€	€	€	€
€FKÍ ÁÜT	î	î	€	€	€	€	F	€	€	í	G	€	€	€	€	€
€FKÉÁÜT	F	FF	€	€	G	€	FF	€	€	í	F	€	€	€	€	€
€FKÍ ÁÜT	í	FF	€	€	H	€	í	€	€	í	H	€	€	€	€	€
€GÉÉÁÜT	G	í	€	€	í	€	í	€	€	FG	G	€	€	€	€	€
€GÍ ÁÜT	í	Fí	€	€	F	€	í	€	€	F€	F	€	€	€	€	€
€GKÉÁÜT	ì	Fí	€	€	F	€	Fí	€	€	J	F	€	€	€	€	€
€GKÍ ÁÜT	FG	G€	€	€	€	€	í	€	€	GG	H	€	€	€	€	€

ÓΡΘΟΓΡΑΦΙΑ ΣΥΛΛΟΓΙΣΜΩΝ

Ό({ ^) ό(ΚΟα Α-Α) * Αοαα@

Ό({ ^) ό(ΚΠΒΑΑ) αι Αη ΙαΑΔΥΕΓΗΑΥΟΑΑ] •

Ό({ ^) ό(ΚΟΒ ΗΑΑ) ΑΑ

Ό({ ^) ό(ΚΥ Αα@ ΙΑ)

Ό({ ^) ό(ΚΟα Α-Α) * Αοαα@	Ό({ ^) ό(ΚΠΒΑΑ) αι Αη ΙαΑΔΥΕΓΗΑΥΟΑΑ] •				Ό({ ^) ό(ΚΟΒ ΗΑΑ) ΑΑ				Ό({ ^) ό(ΚΥ Αα@ ΙΑ)							
	Σ^c	V@	Υα@	Υ^α•	Σ^c	V@	Υα@	Υ^α•	Σ^c	V@	Υα@	Υ^α•	Σ^c	V@	Υα@	Υ^α•
ΕΚΕΑΥ	€	H	€	€	€	€	€	€	€	€	F	F	€	€	€	€
ΕΚΕΑΥ	G	G	€	€	€	H	€	H	€	€	G	F	€	€	€	€
ΕΚΕΑΥ	F	F	€	€	G	€	€	F	€	€	F	€	€	€	€	€
ΕΚΕΑΥ	F	F	€	€	H	€	€	€	€	€	I	G	€	€	€	€
ΕΚΕΑΥ	€	F	€	€	H	€	F	€	€	€	F	I	€	€	€	€
ΕΚΕΑΥ	F	G	€	€	H	€	G	€	€	€	G	G	€	€	€	€
ΕΚΕΑΥ	€	F	€	€	€	€	G	€	€	€	F	I	€	€	€	€
ΕΚΕΑΥ	€	€	€	€	€	€	G	€	€	€	€	I	€	€	€	€

ÓÚÓÇŠÄÜŴÖŠÜÄ

Ö^Ää ^KÖÜ| *!ä Ä^•ää ääFÜFäUŠÖäŠÖÖPÖÖ ÖË] ä
 ÜçäÖä^KÖÜEFG
 ÜçäÖä ^KFEEÄÜT
 ÜäÄ| ä^KEEEEEF
 Ö({ ^) öfKÖä Ä-Ä|) *Ä^ä&@
 Ö({ ^) öKÖbWÄ^ä| Ä| äÄÜË| ÄÜËE-ÄÜÜä] •
 Ö({ ^) öKÖBY ÄÜä|ÄY ä
 Ö({ ^) öKY ^ä@:ÄÜ}} *

ÜçäÖä ^	P^): Ä äÄ) ^ Ü ^ä) ä				Üä ÄY ä Y ^•ä) ä				ÜÜË ÄÜËE-ÄÜÜä] • P ^ä) ä				P^): Ä äÄ) ^ Öää) ä			
	Š^c	V@	Üä @	Ü^ä•	Š^c	V@	Üä @	Ü^ä•	Š^c	V@	Üä @	Ü^ä•	Š^c	V@	Üä @	Ü^ä•
€FKÉÄÜT	€	í	€	€	F	€	H	€	€	F€	€	€	€	€	€	€
€FKÍ ÄÜT	F	í	€	€	î	€	ï	€	€	FF	í	€	€	€	€	€
€FKÉÄÜT	G	ì	€	€	FF	€	FF	€	€	G€	í	€	€	€	€	€
€FKÍ ÄÜT	G	FG	€	€	FF	€	F€	€	€	Fì	í	€	€	€	€	€
€GÉÄÜT	H	l	€	€	FF	€	FF	€	€	Fì	l	€	€	€	€	€
€GÍ ÄÜT	F	ì	€	€	F€	€	Fì	€	€	Fì	G	€	€	€	€	€
€GKÉÄÜT	í	Fí	€	€	l	€	l	€	€	J	G	€	€	€	€	€
€GKÍ ÄÜT	î	FF	€	€	H	€	Fl	€	F	í	í	€	F	€	€	€

ÚÇÊÛÒÐÓÔÛÄÒÐÕÖÏÙ

Ø^Äæ ^KÔÙ| *!æ ÄØ^ææ ææGÜFáÙÏÓæÖÓPØÛT Æ] á
 ÚçæóÄæ^KGØWØEFG
 ÚçæóÄæ^KÍKÈÈÈÈÈT
 Úæ^Ä| á^KÈÈÈÈÈÈÈÈF
 Ô|{ (^) öKÖæ Ä-Ä| }*Ä^ææ@
 Ô|{ (^) öKÞØWæ^}|: Ä|:áÄÇ^}*^ÄÛËÍÄÛËÈHÄÛÄÛ
 Ô|{ (^) öKÖËY HÄ|:ÄËY æ
 Ô|{ (^) öKY ^æ@:HÄ|})*

ÚçæóÄæ ^	P^} :Ä :áÄÇ^)*^ Ü ~ö@ ~}á				Úæ :ÄËY æ Y^*ö@ ~}á				ÛÛËÍØÛËÈHÄÛÄÛæ]* P :ö@ ~}á				P^} :Ä :áÄÇ^)*^ Öæö@ ~}á			
	Š^c	V@*	Üä@	Ú^ä*	Š^c	V@*	Üä@	Ú^ä*	Š^c	V@*	Üä@	Ú^ä*	Š^c	V@*	Üä@	Ú^ä*
€ KÈÈÄT	€	G	F	€	G	€	G	€	I	H	G	€	H€	F	H	€
€ KÍ ÄT	F	H	H	€	í	€	í	€	I	H	í	€	Fí	€	G	€
€ KÈÄT	I	H	í	€	ì	€	ì	€	Î	G	H	€	F€	F	G	€
€ KÍ ÄT	G	Í	F€	€	Fí	€	H€	€	F	H	H	€	í	€	J	€
€ KÈÄT	H	Í	G	€	ì	€	FF	€	Î	Fí	í	€	I	€	I	€
€ KÍ ÄT	H	H€	J	€	H	€	í	€	H	Fí	H	€	í	G	í	€
€ KÈÄT	I	G	í	€	I	€	í	€	I	FG	í	€	ì	€	G	€
€ KÍ ÄT	í	í	FF	€	I	€	I	€	F	í	í	€	FH	€	F	€

UVPÖÜÄÜWÖSÜ

Ü^Aä ^KÖÜI[*!ä ÄQ^äFä ääFÜFäUÖÖSÖÖPÖÖTÜ] ä
 ÜöäÖä^KGÜHÖFEG
 ÜöäÖä ^KI KEEÄÜT
 ÜäÄ[ä^KEEEEEEF
 Ö({ ^) öKÖä Ä-Ä[] *Ä^ä&@
 Ö({ ^) öKÖBÜH^! : Ä[] äÄ[] ^ÄÜÜÈI ÄÜÜÈE-HÄÜÜ
 Ö({ ^) öKÖBY HÜÄ!ÄBY ä
 Ö({ ^) öKY ^ä@!HÜ}} ^

ÜöäÖä ^	P^! : Ä[] äÄ[] ^ Ü[] äÄ[] ^				Üä!ÄBY ä Y^•ä[] ä				ÜÜÈI ÜÜÈE-HÜÜÄ[] • P[] äÄ[] ^				P^! : Ä[] äÄ[] ^ Öää[] ä			
	S^c	V@	Üä @	Ü^ä•	S^c	V@	Üä @	Ü^ä•	S^c	V@	Üä @	Ü^ä•	S^c	V@	Üä @	Ü^ä•
€ KEEÄÜT	€	H	€	€	F	€	€	€	F	G	G	€	€	€	€	€
€ KÍ ÄÜT	€	€	€	€	G	F	€	€	€	G	€	€	F	€	€	€
€ KÍ ÄÜT	€	G	H	€	€	€	€	€	€	€	G	€	€	€	€	€
€ KÍ ÄÜT	€	€	G	€	F	€	€	€	€	€	€	€	€	€	€	€
€ KEEÄÜT	€	€	€	€	€	€	€	€	€	G	F	€	€	€	€	€
€ KÍ ÄÜT	€	€	€	€	F	€	€	€	€	F	G	€	€	€	€	€
€ KEEÄÜT	€	€	€	€	€	€	€	€	€	€	€	€	€	€	€	€
€ KÍ ÄÜT	€	€	€	€	€	€	€	€	€	F	€	€	F	€	€	€

ÖÜPVOEÖÖÜÄÜWÖSÜ

Ö^Aaä ^KÖHÜ| *!ä /Ö^*dä ä:fGÜFaJUÖÖÖÖPÖÖÜT ð] ä
 ÜöäÖäKÖGÜHÖFEG
 ÜöäÖ/ä ^KÍ KEEÖÁÜT
 Üä/Ö| ä^KEEEEEEF
 Ö({ (^) öfKÖä Ä -Äj) * /Öä&@
 Ö({ (^) öfKÖPÖHÖ^)^: /Äj| äÖÖ^)^ ^ÄÜÜËËËÄÜËËÄÜÜÜ
 Ö({ (^) öfKÖBY HÜä/ÖÖY ä
 Ö({ (^) öfKY ^ä@!HÜ}} ^

ÜöäÖ/ä ^	P^)! /Äj äÖÖ^)^ ^ Ü "ö@ ") ä				Üä/ÖÖY ä Y ^• öà ") ä				ÜÜËËËÄÜËËÄÜÜÜä] • P ö@ ") ä				P^)! /Äj äÖÖ^)^ ^ Öä öà ") ä			
	S^c	V@	Üä @	Ü^ä•	S^c	V@	Üä @	Ü^ä•	S^c	V@	Üä @	Ü^ä•	S^c	V@	Üä @	Ü^ä•
€ KEEÁÜT	F€	F	€	€	F	€	F	€	€	F		€	€	€	€	F
€ KÍ ÁÜT	FF	FG	€	€	€	€	i	€	€	GG	€	€	€	€	€	€
€ KÍ ÁÜT	FG	I	€	€	€	€	G	€	€	F	G	€	€	€	€	€
€ KÍ ÁÜT	i	F€	€	€	€	€	H	€	€		€	€	€	€	€	€
€ KEEÁÜT	FF	F	€	€	€	€	€	€	€		F	€	€	€	€	G
€ KÍ ÁÜT	F€	FJ	€	€	F	€	€	€	€	G	G	€	€	€	€	F
€ KÍ ÁÜT	FG	J	€	€	€	€	G	€	€		F	€	€	€	€	F
€ KÍ ÁÜT	F	F	€	€	€	€	€	€	€	i		€	€	€	€	G

ÓÚÓÇŠÄÜŴÖŠÜ

Ö^Aæ ^KÓHÜ| *!æ ÄQ^ææ ææfGÜFajUŠÖšÖÖPÖÖÜT ð] ä
 ÜççÖæ^KGÖWÖEFG
 ÜççÖVä ^KI KEEÉÁÜT
 Üæ^Ö| ä^KEEEEEEF
 Ö({ (^) öfKÖæ Ä -Ä) * Ä^æ&@
 Ö({ (^) öfKÖæÄ^): Ä| äÄÖ^)^ ^ÄÜÜËÏÄÜËE-HÜÖÜ
 Ö({ (^) öfKÖBY HÜA:ÄY æ
 Ö({ (^) öfKY ^æ@:HÜ}) ^

ÜççÖVä ^	P^): Ä äÄÖ^)^ ^ Ü ç@ ^) ä				Üæ:ÄY æ Y ^• ç@ ^) ä				ÜÜËÏÄÜËE-HÜÖÜæ] • P ç@ ^) ä				P^): Ä äÄÖ^)^ ^ Öæ ç@ ^) ä			
	Š^c	V@^	Üä @	Ü^ä•	Š^c	V@^	Üä @	Ü^ä•	Š^c	V@^	Üä @	Ü^ä•	Š^c	V@^	Üä @	Ü^ä•
€ KEEÁÜT	I	FI	€	€	I	€	FI	€	€	G€	€	€	€	€	€	€
€ KÍ ÁÜT	H	FF	€	€	H	€	H	€	€	GJ	F	€	€	€	€	€
€ KÍ ÁÜT	Í	FÍ	€	€	I	€	Í	€	€	G	G	€	€	€	€	€
€ KÍ ÁÜT	Í	FÍ	€	€	F	€	F	€	€	FF	G	€	€	€	€	€
€ KÍ ÁÜT	Í	G	€	€	€	€	€	€	€	Í	€	€	€	€	€	€
€ KÍ ÁÜT	G	H	F	€	€	€	€	€	€	Í	F	€	€	€	€	€
€ KÍ ÁÜT	€	G	H	€	€	€	€	€	€	Í	€	€	€	€	€	€
€ KÍ ÁÜT	G	FJ	€	€	€	€	€	€	€	Í	€	€	€	€	€	€

Intersection Turning Movement

Prepared by:

National Data & Surveying Services

Project ID: CA12_5260_003

Day: MONDAY

City: City of Los Angeles

**Totals
AM**

Date: 06/11/2012

NS/EW Streets:	Navy Way			Navy Way			SR-47			SR-47			TOTAL	
	NORTHBOUND			SOUTHBOUND			EASTBOUND			WESTBOUND				
LANES:	NL	NT	NR	SL	ST	SR	EL	ET	ER	WL	WT	WR		
	2	0	1	0	0	0	0	3	1	2	3	0		
7:00 AM	3		12					405	52	18	425		915	
7:15 AM	7		29					437	68	26	527		1094	
7:30 AM	13		31					500	69	16	557		1186	
7:45 AM	16		36					522	53	8	523		1158	
8:00 AM	22		49					437	17	7	514		1046	
8:15 AM	30		42					423	16	5	410		926	
8:30 AM	19		50					409	10	5	427		920	
8:45 AM	21		82					391	10	7	386		897	
TOTAL VOLUMES :	131	0	331	0	0	0	0	3524	295	92	3769	0	8142	
APPROACH %'s :	28.35%	0.00%	71.65%	#DIV/0!	#DIV/0!	#DIV/0!	0.00%	92.28%	7.72%	2.38%	97.62%	0.00%		
PEAK HR START TIME :	715 AM												TOTAL	
PEAK HR VOL :	58	0	145	0	0	0	0	1896	207	57	2121	0	4484	
PEAK HR FACTOR :	0.715					0.000			0.914			0.950		0.945

CONTROL : Signalized

Intersection Turning Movement

Prepared by:

National Data & Surveying Services

Project ID: CA12_5260_003

Day: MONDAY

City: City of Los Angeles

Totals
PM

Date: 06/11/2012

NS/EW Streets:	Navy Way			Navy Way			SR-47			SR-47			TOTAL
	NORTHBOUND			SOUTHBOUND			EASTBOUND			WESTBOUND			
LANES:	NL	NT	NR	SL	ST	SR	EL	ET	ER	WL	WT	WR	
	2	0	1	0	0	0	0	3	1	2	3	0	
4:00 PM	40		146					520	41	9	394		1150
4:15 PM	82		147					461	48	7	381		1126
4:30 PM	37		105					526	87	26	583		1364
4:45 PM	180		222					555	74	12	581		1624
5:00 PM	85		132					551	53	4	586		1411
5:15 PM	15		78					546	51	12	611		1313
5:30 PM	15		62					505	65	10	535		1192
5:45 PM	15		63					477	30	11	430		1026
TOTAL VOLUMES :	469	0	955	0	0	0	0	4141	449	91	4101	0	10206
APPROACH %'s :	32.94%	0.00%	67.06%	#DIV/0!	#DIV/0!	#DIV/0!	0.00%	90.22%	9.78%	2.17%	97.83%	0.00%	
PEAK HR START TIME :	430 PM												TOTAL
PEAK HR VOL :	317	0	537	0	0	0	0	2178	265	54	2361	0	5712
PEAK HR FACTOR :	0.531			0.000				0.971		0.969			0.879

CONTROL : Signalized

Intersection Turning Movement

Prepared by:

National Data & Surveying Services

Project ID: CA12_5260_003

Day: MONDAY

City: City of Los Angeles

Totals
NOON

Date: 06/11/2012

NS/EW Streets:	Navy Way			Navy Way			SR-47			SR-47			TOTAL
	NORTHBOUND			SOUTHBOUND			EASTBOUND			WESTBOUND			
LANES:	NL	NT	NR	SL	ST	SR	EL	ET	ER	WL	WT	WR	TOTAL
	2	0	1	0	0	0	0	3	1	2	3	0	
11:00 AM	35		86					239	19	10	260		649
11:15 AM	53		110					248	22	2	287		722
11:30 AM	47		91					259	19	5	283		704
11:45 AM	103		135					304	19	3	352		916
12:00 PM	55		79					288	36	8	298		764
12:15 PM	21		79					255	35	4	287		681
12:30 PM	19		59					343	79	17	280		797
12:45 PM	26		55					310	102	14	245		752
TOTAL VOLUMES :	NL	NT	NR	SL	ST	SR	EL	ET	ER	WL	WT	WR	TOTAL
APPROACH %'s :	359	0	694	0	0	0	0	2246	331	63	2292	0	5985
	34.09%	0.00%	65.91%	#DIV/0!	#DIV/0!	#DIV/0!	0.00%	87.16%	12.84%	2.68%	97.32%	0.00%	
PEAK HR START TIME :	1145 AM												TOTAL
PEAK HR VOL :	198	0	352	0	0	0	0	1190	169	32	1217	0	3158
PEAK HR FACTOR :	0.578			0.000			0.805			0.880			0.862

CONTROL : Signalized

ITM Peak Hour Summary

Prepared by:



National Data & Surveying Services

Navy Way and SR-47, City of Los Angeles

Date: 6/11/2012
Day: Monday

Project #: CA12_5260_003

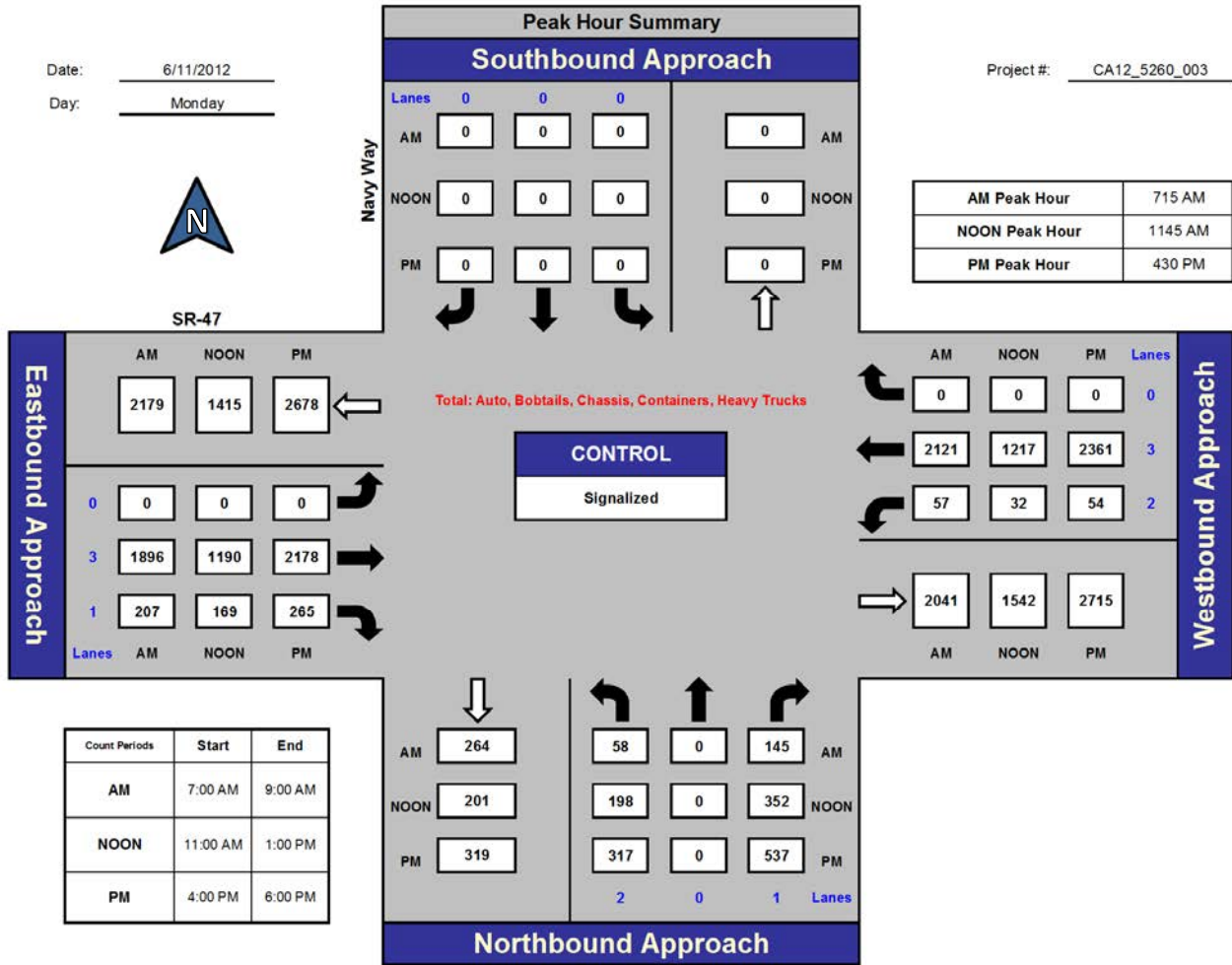

Total Ins & Outs

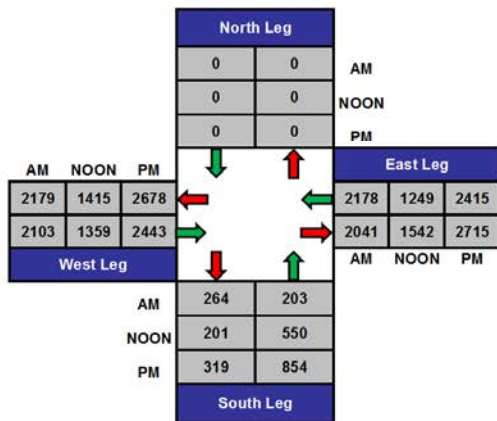

Total Volume Per Leg

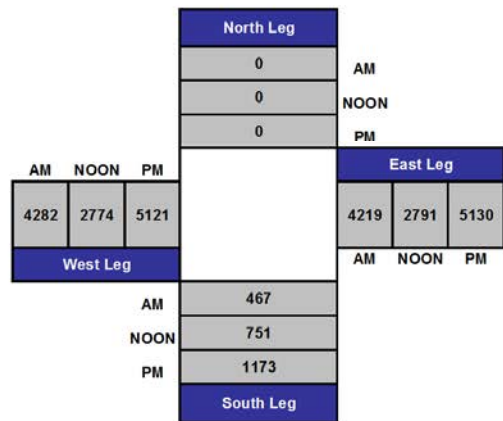

Intersection Turning Movement

Prepared by:

National Data & Surveying Services

Project ID: CA12_5260_003

Day: MONDAY

City: City of Los Angeles

PASSENGER VEHICLES

Date: 06/11/2012

AM

NS/EW Streets:	Navy Way			Navy Way			SR-47			SR-47			TOTAL
	NORTHBOUND			SOUTHBOUND			EASTBOUND			WESTBOUND			
LANES:	NL	NT	NR	SL	ST	SR	EL	ET	ER	WL	WT	WR	
7:00 AM	3		12					389	45	18	388		855
7:15 AM	6		29					421	62	25	493		1036
7:30 AM	2		31					471	65	16	515		1100
7:45 AM	6		36					496	41	7	482		1068
8:00 AM	13		49					413	5	5	468		953
8:15 AM	21		42					389	6	5	363		826
8:30 AM	5		50					364	5	5	363		792
8:45 AM	11		82					332	2	7	325		759

	NL	NT	NR	SL	ST	SR	EL	ET	ER	WL	WT	WR	TOTAL
TOTAL VOLUMES :	67	0	331	0	0	0	0	3275	231	88	3397	0	7389
APPROACH %'s :	16.83%	0.00%	83.17%	#DIV/0!	#DIV/0!	#DIV/0!	0.00%	93.41%	6.59%	2.53%	97.47%	0.00%	

PEAK HR START TIME :	715 AM												TOTAL
PEAK HR VOL :	27	0	145	0	0	0	0	1801	173	53	1958	0	4157
PEAK HR FACTOR :	0.694			0.000			0.919			0.947			0.945

CONTROL : Signalized

8-9 AM	50	0	223	0	0	0	0	1498	18	22	1519	0
--------	----	---	-----	---	---	---	---	------	----	----	------	---

Intersection Turning Movement

Prepared by:

National Data & Surveying Services

Project ID: CA12_5260_003

Day: MONDAY

City: City of Los Angeles

PASSENGER VEHICLES

Date: 06/11/2012

PM

NS/EW Streets:	Navy Way			Navy Way			SR-47			SR-47			TOTAL
	NORTHBOUND			SOUTHBOUND			EASTBOUND			WESTBOUND			
LANES:	NL	NT	NR	SL	ST	SR	EL	ET	ER	WL	WT	WR	
4:00 PM	20		146					446	30	9	335		986
4:15 PM	71		147					411	41	7	321		998
4:30 PM	31		105					497	75	26	513		1247
4:45 PM	172		222					534	64	12	532		1536
5:00 PM	83		132					531	31	4	525		1306
5:15 PM	13		78					538	40	11	568		1248
5:30 PM	13		62					491	51	9	480		1106
5:45 PM	10		63					453	21	9	368		924
TOTAL VOLUMES :	413	0	955	0	0	0	0	3901	353	87	3642	0	9351
APPROACH %'s :	30.19%	0.00%	69.81%	#DIV/0!	#DIV/0!	#DIV/0!	0.00%	91.70%	8.30%	2.33%	97.67%	0.00%	
PEAK HR START TIME :	430 PM												TOTAL
PEAK HR VOL :	299	0	537	0	0	0	0	2100	210	53	2138	0	5337
PEAK HR FACTOR :	0.530		0.000			0.966			0.946			0.869	

CONTROL : Signalized

4-5 PM 294 0 620 0 0 0 0 1888 210 54 1701 0

Intersection Turning Movement

Prepared by:

National Data & Surveying Services

Project ID: CA12_5260_003

Day: MONDAY

City: City of Los Angeles

HEAVY TRUCKS

Date: 06/11/2012

NOON

NS/EW Streets:	Navy Way			Navy Way			SR-47			SR-47			TOTAL
	NORTHBOUND			SOUTHBOUND			EASTBOUND			WESTBOUND			
LANES:	NL	NT	NR	SL	ST	SR	EL	ET	ER	WL	WT	WR	
11:00 AM	23		86					185	9	9	200		512
11:15 AM	42		110					181	7	1	212		553
11:30 AM	30		91					207	13	4	239		584
11:45 AM	93		135					250	11	2	296		787
12:00 PM	46		79					256	26	7	229		643
12:15 PM	12		79					222	27	4	246		590
12:30 PM	9		59					309	71	16	229		693
12:45 PM	11		55					276	92	13	199		646
TOTAL VOLUMES :	266	0	694	0	0	0	0	1886	256	56	1850	0	5008
APPROACH %'s :	27.71%	0.00%	72.29%	#DIV/0!	#DIV/0!	#DIV/0!	0.00%	88.05%	11.95%	2.94%	97.06%	0.00%	
PEAK HR START TIME :	1145 AM												TOTAL
PEAK HR VOL :	160	0	352	0	0	0	0	1037	135	29	1000	0	2713
PEAK HR FACTOR :	0.561			0.000				0.771		0.863			0.862

CONTROL : Signalized

ITM Peak Hour Summary

Prepared by:



National Data & Surveying Services

Navy Way and SR-47, City of Los Angeles

Date: 6/11/2012
Day: Monday

Project #: CA12_5260_003

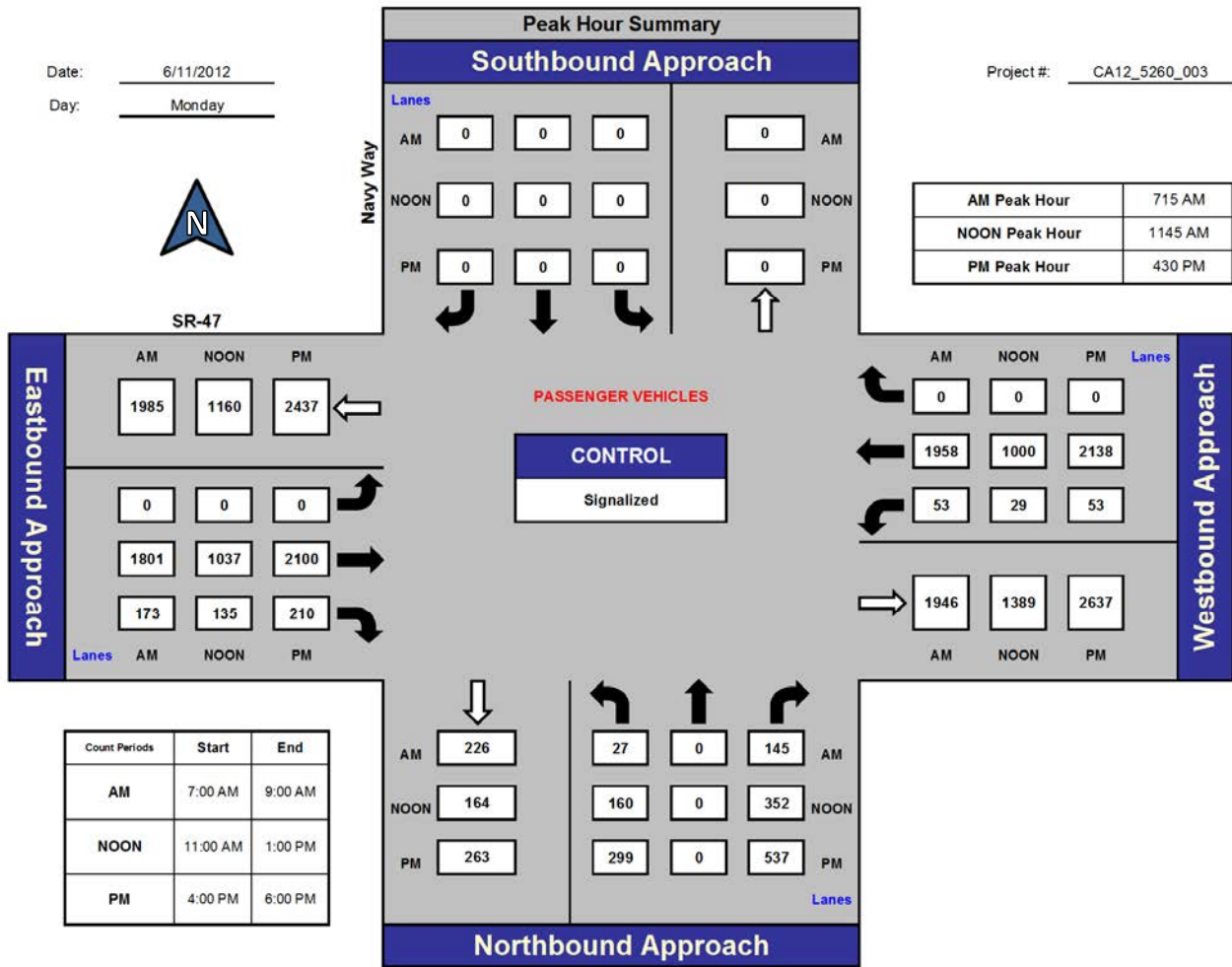

Total Ins & Outs

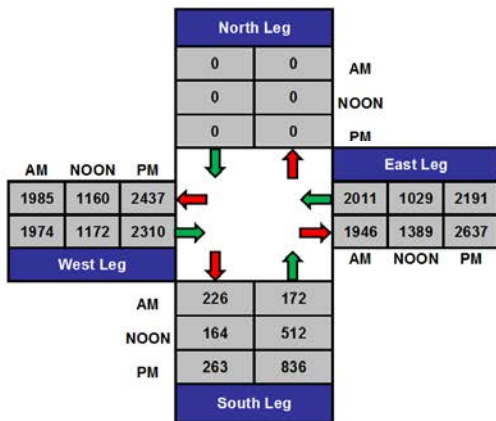

Total Volume Per Leg

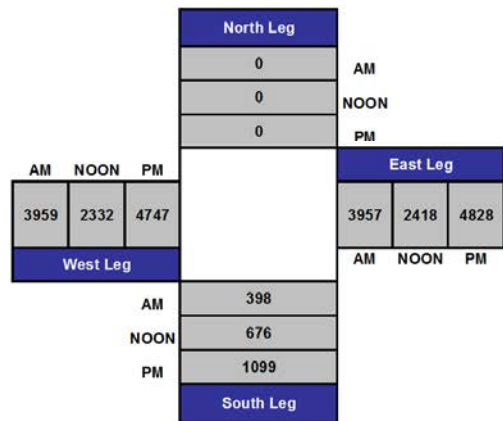

Intersection Turning Movement

Prepared by:

National Data & Surveying Services

Project ID: CA12_5260_003

Day: MONDAY

City: City of Los Angeles

CONTAINERS

Date: 06/11/2012

AM

NS/EW Streets:	Navy Way			Navy Way			SR-47			SR-47			TOTAL
	NORTHBOUND			SOUTHBOUND			EASTBOUND			WESTBOUND			
LANES:	NL	NT	NR	SL	ST	SR	EL	ET	ER	WL	WT	WR	
	2	0	1	0	0	0	0	3	1	2	3	0	
7:00 AM	0							3	7	0	16		26
7:15 AM	0							4	4	0	17		25
7:30 AM	1							7	2	0	22		32
7:45 AM	2							11	6	1	17		37
8:00 AM	4							7	6	0	22		39
8:15 AM	5							15	4	0	22		46
8:30 AM	8							24	5	0	23		60
8:45 AM	8							26	4	0	29		67
TOTAL VOLUMES :	28	0	0	0	0	0	0	97	38	1	168	0	332
APPROACH %'s :	100.00%	0.00%	0.00%	#DIV/0!	#DIV/0!	#DIV/0!	0.00%	71.85%	28.15%	0.59%	99.41%	0.00%	
PEAK HR START TIME :	800 AM												TOTAL
PEAK HR VOL :	25	0	0	0	0	0	0	72	19	0	96	0	212
PEAK HR FACTOR :	0.781			0.000			0.758			0.828			0.791

CONTROL : Signalized

Intersection Turning Movement

Prepared by:

National Data & Surveying Services

Project ID: CA12_5260_003

Day: MONDAY

City: City of Los Angeles

CONTAINERS

Date: 06/11/2012

PM

NS/EW Streets:	Navy Way			Navy Way			SR-47			SR-47			TOTAL
	NORTHBOUND			SOUTHBOUND			EASTBOUND			WESTBOUND			
LANES:	NL	NT	NR	SL	ST	SR	EL	ET	ER	WL	WT	WR	
	2	0	1	0	0	0	0	3	1	2	3	0	
4:00 PM	8							37	7	0	27		79
4:15 PM	4							23	7	0	27		61
4:30 PM	3							16	9	0	40		68
4:45 PM	1							8	5	0	28		42
5:00 PM	1							8	11	0	32		52
5:15 PM	0							4	8	0	23		35
5:30 PM	0							5	6	0	34		45
5:45 PM	3							8	3	2	41		57
TOTAL VOLUMES :	20	0	0	0	0	0	0	109	56	2	252	0	439
APPROACH %'s :	100.00%	0.00%	0.00%	#DIV/0!	#DIV/0!	#DIV/0!	0.00%	66.06%	33.94%	0.79%	99.21%	0.00%	
PEAK HR START TIME :	400 PM												TOTAL
PEAK HR VOL :	16	0	0	0	0	0	0	84	28	0	122	0	250
PEAK HR FACTOR :	0.500			0.000			0.636			0.763			0.791

CONTROL : Signalized

Intersection Turning Movement

Prepared by:

National Data & Surveying Services

Project ID: CA12_5260_003

Day: MONDAY

City: City of Los Angeles

CONTAINERS

Date: 06/11/2012

NOON

NS/EW Streets:	Navy Way			Navy Way			SR-47			SR-47			TOTAL
	NORTHBOUND			SOUTHBOUND			EASTBOUND			WESTBOUND			
LANES:	NL	NT	NR	SL	ST	SR	EL	ET	ER	WL	WT	WR	
	2	0	1	0	0	0	0	3	1	2	3	0	
11:00 AM	8							31	8	0	27		74
11:15 AM	8							38	10	1	40		97
11:30 AM	12							24	5	1	30		72
11:45 AM	9							27	6	0	25		67
12:00 PM	5							19	6	0	41		71
12:15 PM	3							14	5	0	21		43
12:30 PM	5							19	3	0	30		57
12:45 PM	9							9	5	1	28		52
TOTAL VOLUMES :	59	0	0	0	0	0	0	181	48	3	242	0	533
APPROACH %'s :	100.00%	0.00%	0.00%	#DIV/0!	#DIV/0!	#DIV/0!	0.00%	79.04%	20.96%	1.22%	98.78%	0.00%	
PEAK HR START TIME :	1100 AM												TOTAL
PEAK HR VOL :	37	0	0	0	0	0	0	120	29	2	122	0	310
PEAK HR FACTOR :	0.771			0.000			0.776			0.756			0.799

CONTROL : Signalized

ITM Peak Hour Summary

Prepared by:



National Data & Surveying Services

Navy Way and SR-47, City of Los Angeles

Date: 6/11/2012
Day: Monday

Project #: CA12_5260_003

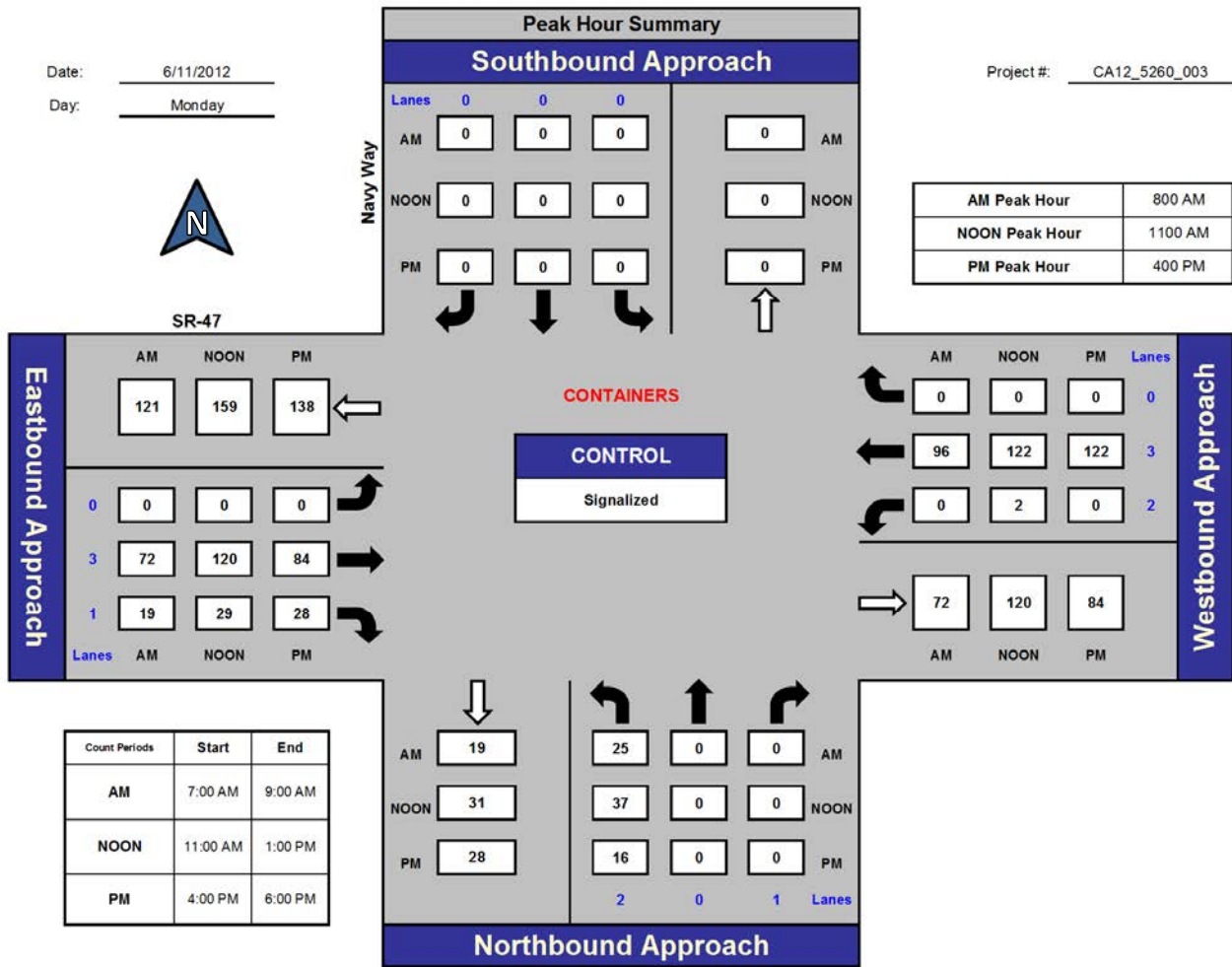

Total Ins & Outs

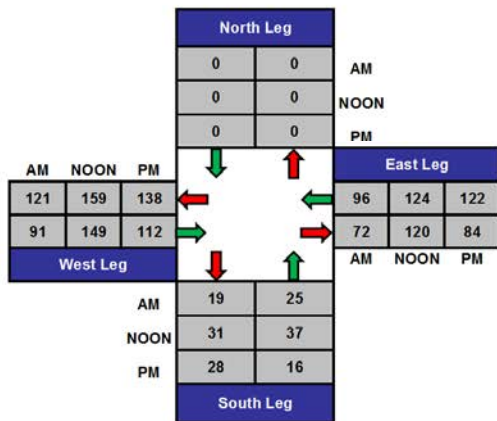

Total Volume Per Leg

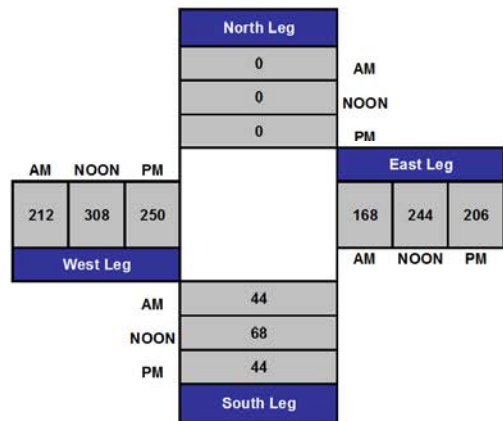

Intersection Turning Movement

Prepared by:

National Data & Surveying Services

Project ID: CA12_5260_003

Day: MONDAY

City: City of Los Angeles

HEAVY TRUCKS

Date: 06/11/2012

AM

NS/EW Streets:	Navy Way			Navy Way			SR-47			SR-47			TOTAL
	NORTHBOUND			SOUTHBOUND			EASTBOUND			WESTBOUND			
LANES:	NL	NT	NR	SL	ST	SR	EL	ET	ER	WL	WT	WR	
	2	0	1	0	0	0	0	3	1	2	3	0	
7:00 AM	0							11	0	0	9		20
7:15 AM	1							8	1	1	3		14
7:30 AM	0							14	0	0	8		22
7:45 AM	0							6	0	0	10		16
8:00 AM	0							9	0	1	5		15
8:15 AM	0							13	1	0	2		16
8:30 AM	2							10	0	0	12		24
8:45 AM	0							9	0	0	13		22
TOTAL VOLUMES :	3	0	0	0	0	0	0	80	2	2	62	0	149
APPROACH %'s :	100.00%	0.00%	0.00%	#DIV/0!	#DIV/0!	#DIV/0!	0.00%	97.56%	2.44%	3.13%	96.88%	0.00%	
PEAK HR START TIME :	800 AM												TOTAL
PEAK HR VOL :	2	0	0	0	0	0	0	41	1	1	32	0	77
PEAK HR FACTOR :	0.250			0.000			0.750			0.635			0.802

CONTROL : Signalized

Intersection Turning Movement

Prepared by:

National Data & Surveying Services

Project ID: CA12_5260_003

Day: MONDAY

City: City of Los Angeles

HEAVY TRUCKS

Date: 06/11/2012

PM

NS/EW Streets:	Navy Way			Navy Way			SR-47			SR-47			TOTAL
	NORTHBOUND			SOUTHBOUND			EASTBOUND			WESTBOUND			
LANES:	NL	NT	NR	SL	ST	SR	EL	ET	ER	WL	WT	WR	
	2	0	1	0	0	0	0	3	1	2	3	0	
4:00 PM								9	0	0	5		14
4:15 PM								14	0	0	4		18
4:30 PM								2	0	0	1		3
4:45 PM								6	0	0	3		9
5:00 PM								6	1	0	2		9
5:15 PM								2	0	0	3		5
5:30 PM								1	0	1	3		5
5:45 PM								7	0	0	1		8
TOTAL VOLUMES :	0	0	0	0	0	0	0	47	1	1	22	0	71
APPROACH %'s :	#DIV/0!	#DIV/0!	#DIV/0!	#DIV/0!	#DIV/0!	#DIV/0!	0.00%	97.92%	2.08%	4.35%	95.65%	0.00%	
PEAK HR START TIME :	400 PM												TOTAL
PEAK HR VOL :	0	0	0	0	0	0	0	31	0	0	13	0	44
PEAK HR FACTOR :	0.000			0.000			0.554			0.650			0.611

CONTROL : Signalized

Intersection Turning Movement

Prepared by:

National Data & Surveying Services

Project ID: CA12_5260_003

Day: MONDAY

City: City of Los Angeles

HEAVY TRUCKS

Date: 06/11/2012

NOON

NS/EW Streets:	Navy Way			Navy Way			SR-47			SR-47			TOTAL
	NORTHBOUND			SOUTHBOUND			EASTBOUND			WESTBOUND			
LANES:	NL	NT	NR	SL	ST	SR	EL	ET	ER	WL	WT	WR	
	2	0	1	0	0	0	0	3	1	2	3	0	
11:00 AM	0							10	0	0	7		17
11:15 AM	0							9	0	0	7		16
11:30 AM	1							10	1	0	9		21
11:45 AM	0							10	0	1	11		22
12:00 PM	0							9	0	1	10		20
12:15 PM	0							7	1	0	9		17
12:30 PM	0							8	0	1	10		19
12:45 PM	2							11	1	0	5		19
TOTAL VOLUMES :	3	0	0	0	0	0	0	74	3	3	68	0	151
APPROACH %'s :	100.00%	0.00%	0.00%	#DIV/0!	#DIV/0!	#DIV/0!	0.00%	96.10%	3.90%	4.23%	95.77%	0.00%	
PEAK HR START TIME :	1130 AM												TOTAL
PEAK HR VOL :	1	0	0	0	0	0	0	36	2	2	39	0	80
PEAK HR FACTOR :	0.250			0.000			0.864			0.854			0.909

CONTROL : Signalized

ITM Peak Hour Summary

Prepared by:



National Data & Surveying Services

Navy Way and SR-47, City of Los Angeles

Date: 6/11/2012
Day: Monday

Project #: CA12_5260_003

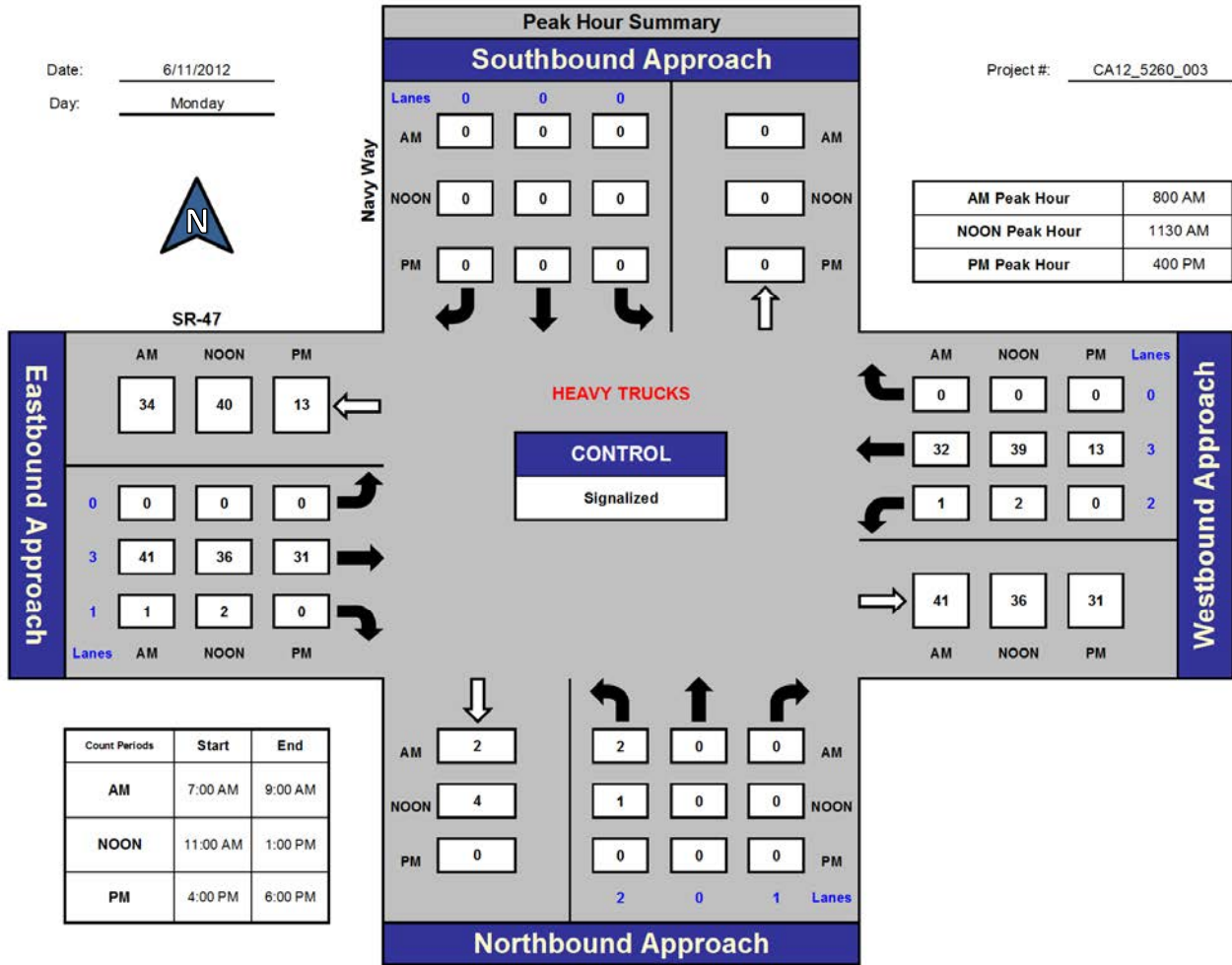

Total Ins & Outs

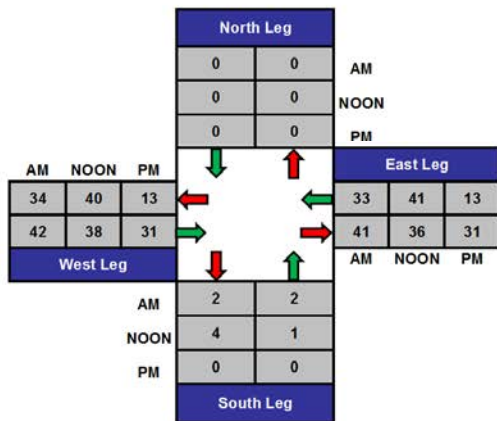

Total Volume Per Leg

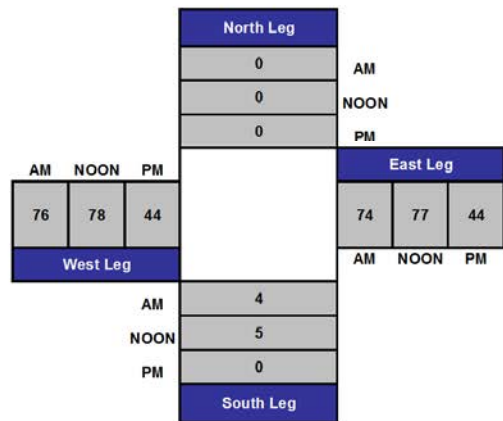

Intersection Turning Movement

Prepared by:

National Data & Surveying Services

Project ID: CA12_5260_003

Day: MONDAY

City: City of Los Angeles

CHASSIS

Date: 06/11/2012

AM

NS/EW Streets:	Navy Way			Navy Way			SR-47			SR-47			TOTAL
	NORTHBOUND			SOUTHBOUND			EASTBOUND			WESTBOUND			
LANES:	NL	NT	NR	SL	ST	SR	EL	ET	ER	WL	WT	WR	
	2	0	1	0	0	0	0	3	1	2	3	0	
7:00 AM								1	0	0	1		2
7:15 AM								1	0	0	2		3
7:30 AM								1	0	0	1		2
7:45 AM								4	0	0	0		4
8:00 AM								1	0	1	0		2
8:15 AM								0	1	0	1		2
8:30 AM								1	0	0	4		5
8:45 AM								2	1	0	3		6
TOTAL VOLUMES :	0	0	0	0	0	0	0	11	2	1	12	0	26
APPROACH %'s :	#DIV/0!	#DIV/0!	#DIV/0!	#DIV/0!	#DIV/0!	#DIV/0!	0.00%	84.62%	15.38%	7.69%	92.31%	0.00%	
PEAK HR START TIME :	800 AM												TOTAL
PEAK HR VOL :	0	0	0	0	0	0	0	4	2	1	8	0	15
PEAK HR FACTOR :	0.000			0.000			0.500			0.563			0.625

CONTROL : Signalized

Intersection Turning Movement

Prepared by:

National Data & Surveying Services

Project ID: CA12_5260_003

Day: MONDAY

City: City of Los Angeles

CHASSIS

Date: 06/11/2012

PM

NS/EW Streets:	Navy Way			Navy Way			SR-47			SR-47			TOTAL
	NORTHBOUND			SOUTHBOUND			EASTBOUND			WESTBOUND			
LANES:	NL	NT	NR	SL	ST	SR	EL	ET	ER	WL	WT	WR	
	2	0	1	0	0	0	0	3	1	2	3	0	
4:00 PM	1							7	0	0	2		10
4:15 PM	1							4	0	0	6		11
4:30 PM	1							4	0	0	2		7
4:45 PM	0							2	0	0	1		3
5:00 PM	0							1	0	0	2		3
5:15 PM	0							0	0	1	0		1
5:30 PM	0							1	0	0	1		2
5:45 PM	0							0	1	0	1		2
TOTAL VOLUMES :	3	0	0	0	0	0	0	19	1	1	15	0	39
APPROACH %'s :	100.00%	0.00%	0.00%	#DIV/0!	#DIV/0!	#DIV/0!	0.00%	95.00%	5.00%	6.25%	93.75%	0.00%	
PEAK HR START TIME :	400 PM												TOTAL
PEAK HR VOL :	3	0	0	0	0	0	0	17	0	0	11	0	31
PEAK HR FACTOR :	0.750			0.000			0.607			0.458			0.705

CONTROL : Signalized

Intersection Turning Movement

Prepared by:

National Data & Surveying Services

Project ID: CA12_5260_003

Day: MONDAY

City: City of Los Angeles

CHASSIS

Date: 06/11/2012

NOON

NS/EW Streets:	Navy Way			Navy Way			SR-47			SR-47			TOTAL
	NORTHBOUND			SOUTHBOUND			EASTBOUND			WESTBOUND			
LANES:	NL	NT	NR	SL	ST	SR	EL	ET	ER	WL	WT	WR	TOTAL
	2	0	1	0	0	0	0	3	1	2	3	0	
11:00 AM	0							2		1	2		5
11:15 AM	2							4		0	8		14
11:30 AM	1							2		0	3		6
11:45 AM	0							4		0	2		6
12:00 PM	0							2		0	2		4
12:15 PM	2							4		0	1		7
12:30 PM	0							2		0	2		4
12:45 PM	1							4		0	5		10
TOTAL VOLUMES :	6	0	0	0	0	0	0	24	0	1	25	0	56
APPROACH %'s :	100.00%	0.00%	0.00%	#DIV/0!	#DIV/0!	#DIV/0!	0.00%	100.00%	0.00%	3.85%	96.15%	0.00%	
PEAK HR START TIME :	1100 AM												TOTAL
PEAK HR VOL :	3	0	0	0	0	0	0	12	0	1	15	0	31
PEAK HR FACTOR :	0.375			0.000			0.750			0.500			0.554

CONTROL : Signalized

ITM Peak Hour Summary

Prepared by:



National Data & Surveying Services

Navy Way and SR-47, City of Los Angeles

Date: 6/11/2012
Day: Monday

Project #: CA12_5260_003

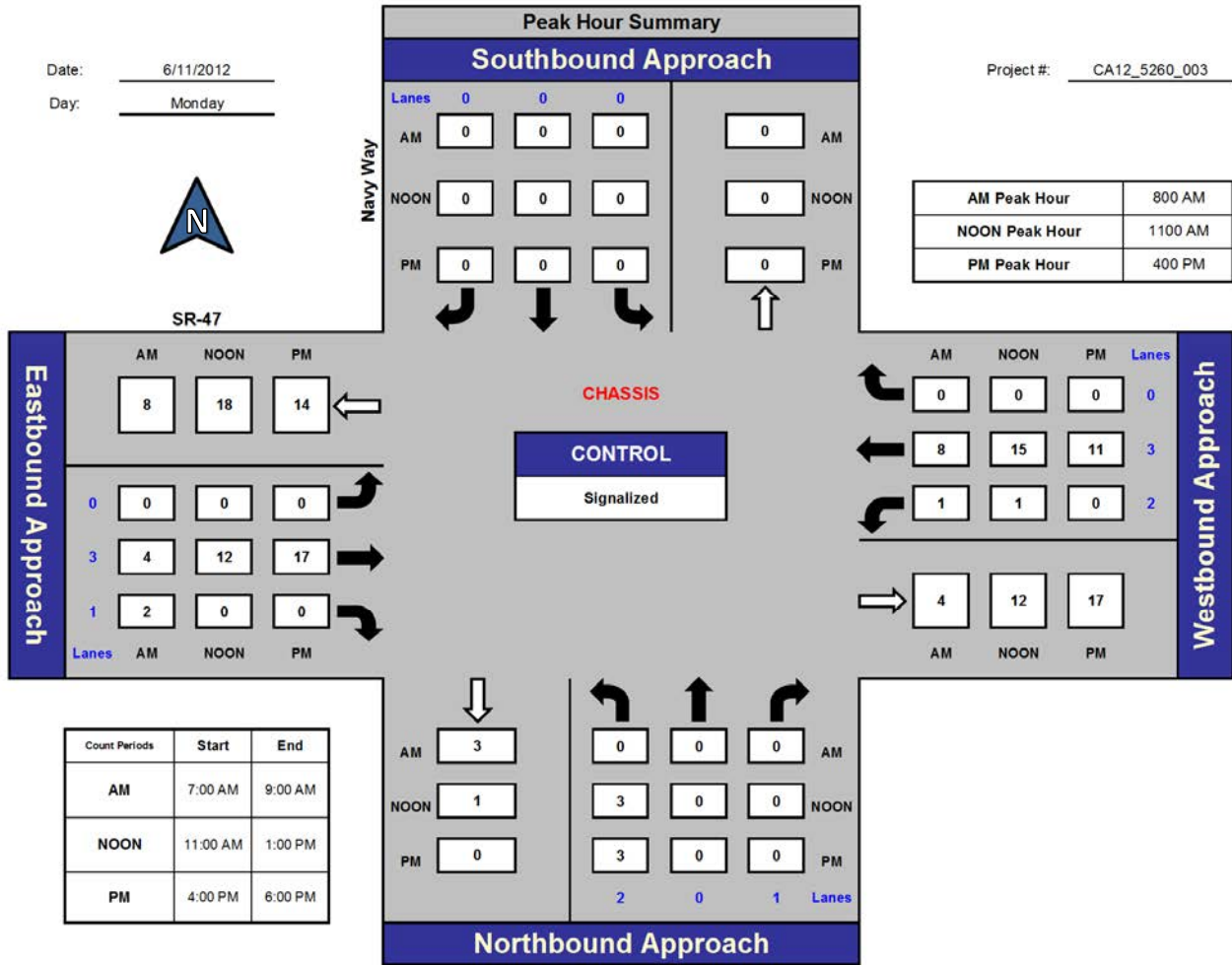

Total Ins & Outs

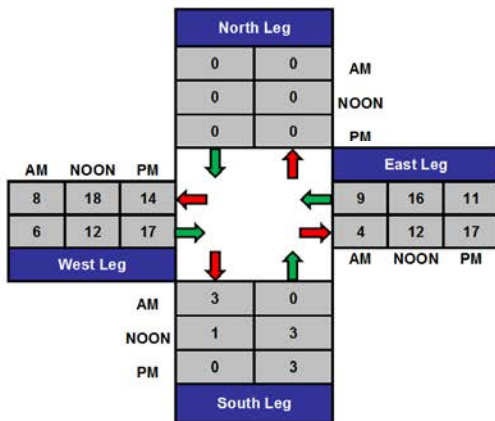

Total Volume Per Leg

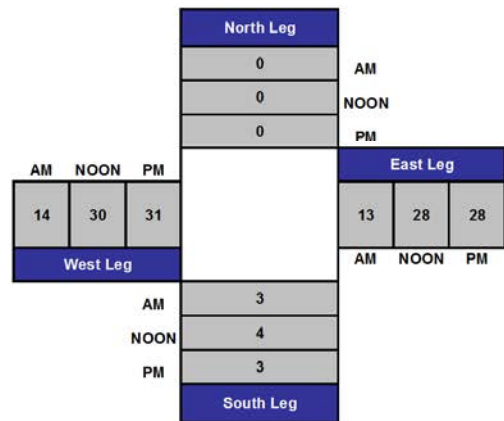

Intersection Turning Movement

Prepared by:

National Data & Surveying Services

Project ID: CA12_5260_003

Day: MONDAY

City: City of Los Angeles

BOBTAILS

Date: 06/11/2012

AM

NS/EW Streets:	Navy Way			Navy Way			SR-47			SR-47			TOTAL
	NORTHBOUND			SOUTHBOUND			EASTBOUND			WESTBOUND			
LANES:	NL	NT	NR	SL	ST	SR	EL	ET	ER	WL	WT	WR	
	2	0	1	0	0	0	0	3	1	2	3	0	
7:00 AM	0							1	0		11		12
7:15 AM	0							3	1		12		16
7:30 AM	10							7	2		11		30
7:45 AM	8							5	6		14		33
8:00 AM	5							7	6		19		37
8:15 AM	4							6	4		22		36
8:30 AM	4							10	0		25		39
8:45 AM	2							22	3		16		43
TOTAL VOLUMES :	33	0	0	0	0	0	0	61	22	0	130	0	246
APPROACH %'s :	100.00%	0.00%	0.00%	#DIV/0!	#DIV/0!	#DIV/0!	0.00%	73.49%	26.51%	0.00%	100.00%	0.00%	
PEAK HR START TIME :	800 AM												TOTAL
PEAK HR VOL :	15	0	0	0	0	0	0	45	13	0	82	0	155
PEAK HR FACTOR :	0.750			0.000			0.580			0.820			0.901

CONTROL : Signalized

Intersection Turning Movement

Prepared by:

National Data & Surveying Services

Project ID: CA12_5260_003

Day: MONDAY

City: City of Los Angeles

BOBTAILS

Date: 06/11/2012

PM

NS/EW Streets:	Navy Way			Navy Way			SR-47			SR-47			TOTAL
	NORTHBOUND			SOUTHBOUND			EASTBOUND			WESTBOUND			
LANES:	NL	NT	NR	SL	ST	SR	EL	ET	ER	WL	WT	WR	
	2	0	1	0	0	0	0	3	1	2	3	0	
4:00 PM	11							21	4		25		61
4:15 PM	6							9	0		23		38
4:30 PM	2							7	3		27		39
4:45 PM	7							5	5		17		34
5:00 PM	1							5	10		25		41
5:15 PM	2							2	3		17		24
5:30 PM	2							7	8		17		34
5:45 PM	2							9	5		19		35
TOTAL VOLUMES :	33	0	0	0	0	0	0	65	38	0	170	0	306
APPROACH %'s :	100.00%	0.00%	0.00%	#DIV/0!	#DIV/0!	#DIV/0!	0.00%	63.11%	36.89%	0.00%	100.00%	0.00%	
PEAK HR START TIME :	400 PM												TOTAL
PEAK HR VOL :	26	0	0	0	0	0	0	42	12	0	92	0	172
PEAK HR FACTOR :	0.591			0.000			0.540			0.852			0.705

CONTROL : Signalized

Intersection Turning Movement

Prepared by:

National Data & Surveying Services

Project ID: CA12_5260_003

Day: MONDAY

City: City of Los Angeles

BOBTAILS

Date: 06/11/2012

NOON

NS/EW Streets:	Navy Way			Navy Way			SR-47			SR-47			TOTAL
	NORTHBOUND			SOUTHBOUND			EASTBOUND			WESTBOUND			
LANES:	NL	NT	NR	SL	ST	SR	EL	ET	ER	WL	WT	WR	
	2	0	1	0	0	0	0	3	1	2	3	0	
11:00 AM	4							11	2		24		41
11:15 AM	1							16	5		20		42
11:30 AM	3							16	0		2		21
11:45 AM	1							13	2		18		34
12:00 PM	4							2	4		16		26
12:15 PM	4							8	2		10		24
12:30 PM	5							5	5		9		24
12:45 PM	3							10	4		8		25
TOTAL VOLUMES :	25	0	0	0	0	0	0	81	24	0	107	0	237
APPROACH %'s :	100.00%	0.00%	0.00%	#DIV/0!	#DIV/0!	#DIV/0!	0.00%	77.14%	22.86%	0.00%	100.00%	0.00%	
PEAK HR START TIME :	1100 AM												TOTAL
PEAK HR VOL :	9	0	0	0	0	0	0	56	9	0	64	0	138
PEAK HR FACTOR :	0.563			0.000			0.774			0.667			0.821

CONTROL : Signalized

ITM Peak Hour Summary

Prepared by:



National Data & Surveying Services

Navy Way and SR-47, City of Los Angeles

Date: 6/11/2012
Day: Monday

Project #: CA12_5260_003

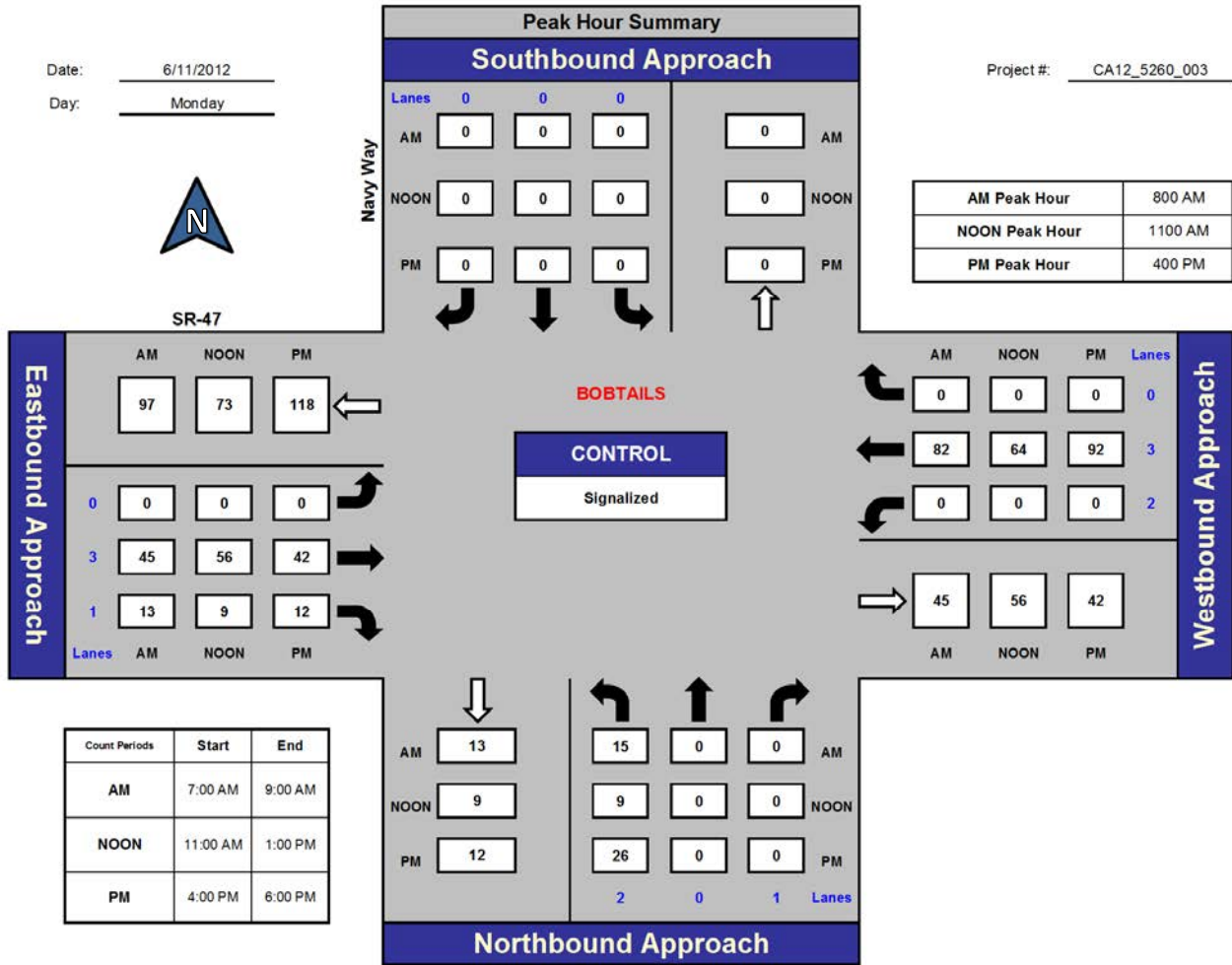

Total Ins & Outs

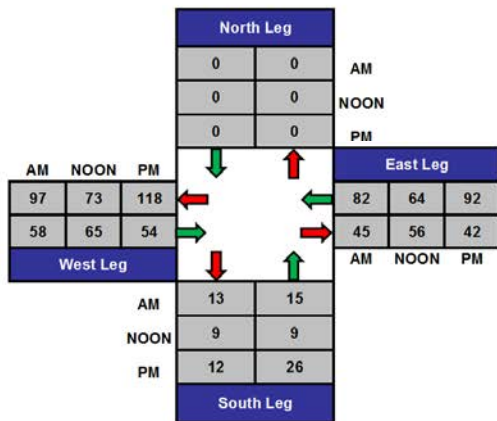

Total Volume Per Leg

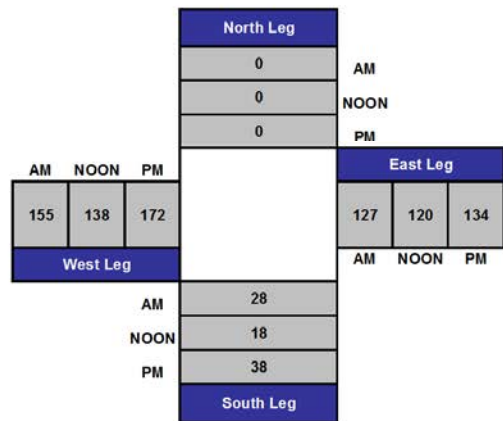

ÚÇÈÛÒÞÔÖÙÀÒÐÕÐÕÒ

ÚÇÈÛÒÞÔÖÙÀÒÐÕÐÕÒ
 ÚÇÈÛÒÞÔÖÙÀÒÐÕÐÕÒ
 ÚÇÈÛÒÞÔÖÙÀÒÐÕÐÕÒ
 ÚÇÈÛÒÞÔÖÙÀÒÐÕÐÕÒ
 ÚÇÈÛÒÞÔÖÙÀÒÐÕÐÕÒ
 ÚÇÈÛÒÞÔÖÙÀÒÐÕÐÕÒ
 ÚÇÈÛÒÞÔÖÙÀÒÐÕÐÕÒ

ÚÇÈÛÒÞÔÖÙÀÒÐÕÐÕÒ	ÚÇÈÛÒÞÔÖÙÀÒÐÕÐÕÒ				ÚÇÈÛÒÞÔÖÙÀÒÐÕÐÕÒ				ÚÇÈÛÒÞÔÖÙÀÒÐÕÐÕÒ				ÚÇÈÛÒÞÔÖÙÀÒÐÕÐÕÒ				
	ÚÇÈÛÒÞÔÖÙÀÒÐÕÐÕÒ	ÚÇÈÛÒÞÔÖÙÀÒÐÕÐÕÒ	ÚÇÈÛÒÞÔÖÙÀÒÐÕÐÕÒ	ÚÇÈÛÒÞÔÖÙÀÒÐÕÐÕÒ	ÚÇÈÛÒÞÔÖÙÀÒÐÕÐÕÒ	ÚÇÈÛÒÞÔÖÙÀÒÐÕÐÕÒ	ÚÇÈÛÒÞÔÖÙÀÒÐÕÐÕÒ	ÚÇÈÛÒÞÔÖÙÀÒÐÕÐÕÒ	ÚÇÈÛÒÞÔÖÙÀÒÐÕÐÕÒ	ÚÇÈÛÒÞÔÖÙÀÒÐÕÐÕÒ	ÚÇÈÛÒÞÔÖÙÀÒÐÕÐÕÒ	ÚÇÈÛÒÞÔÖÙÀÒÐÕÐÕÒ	ÚÇÈÛÒÞÔÖÙÀÒÐÕÐÕÒ	ÚÇÈÛÒÞÔÖÙÀÒÐÕÐÕÒ	ÚÇÈÛÒÞÔÖÙÀÒÐÕÐÕÒ	ÚÇÈÛÒÞÔÖÙÀÒÐÕÐÕÒ	ÚÇÈÛÒÞÔÖÙÀÒÐÕÐÕÒ
€ €€€€€	€	€	€	€	I	FI	F	€	F€	€	GG	€	€	I	FF	€	
€ €€€€€	€	€	€	€	IJ	FII	F	€	F€	€	GG	€	F	IJ	FH	€	
€ €€€€€	F	€	€	€	I	FII	H	€	F€	€	HH	€	€	I	FI	€	
€ €€€€€	G	€	€	€	I	FII	J	€	G€	F	GF	€	€	I	F€	€	
€ €€€€€	F	€	€	€	H	FHH	G	€	FF	€	IG	€	G	I	G	€	
€ €€€€€	F	€	€	€	GG	FHE	€	€	€	€	HF	€	€	I€	I	€	
€ €€€€€	€	€	€	€	GG	FFI	€	€	F€	F	G€	€	€	I	H	FF	€
€ €€€€€	€	€	€	€	H	IG	€	€	I	€	FI	€	€	I	I	i	€

ÖÜPVOÖÖÜÄÜWÖSÜ

Ö^Ää ^KÖÜ| *!ä Ä^ä ää ääGÜFäUÖÖÖFÜÖÖFÜ] ä
 ÜöäÖä^KÖÖ ÖÖFG
 ÜöäÖä ^Kí KÖÖÖÖF
 ÜäÄ| ä^KÖÖÖÖÖF
 Ö({ (^) öKÖä Ä -Ä) * Ä^ä@
 Ö({ (^) öKÖÜÜÜFÖH!{ ä äÄ|ä äÄ, ^Ää] •
 Ö({ (^) öKÖY HÜ) |ç^ääÖ |çää
 Ö({ (^) öKY ^ä@:HÜ))

ÜöäÖä ^	Üä^ä Ü ö@ ^ ä				Ü^ ç^ääÖ çää Y ^ • çä ^ ä				ÜÜFÖH!{ ä äÄ ä äÄ, ^Ää] P ö@ ^ ä				Ü^ ç^ääÖ çää Öä çä ^ ä				
	S^c	V@	Üä @	Ü^ä•	S^c	V@	Üä @	Ü^ä•	S^c	V@	Üä @	Ü^ä•	S^c	V@	Üä @	Ü^ä•	
ë KÖÖF	€	€	€	€	€	F	€	€	€	F	€	€	€	F	€	G	€
ë Kí ÖF	€	€	€	€	€	€	€	€	€	I	€	€	€	H	€	FI	€
ë Kí ÖF	€	€	€	€	€	€	€	€	€	H	G	€	€	€	€	G	€
ë Kí ÖF	€	€	€	€	€	€	€	€	€	€	G	€	€	€	€	GF	€
ë KÖÖF	€	€	€	€	€	€	€	€	€	H	H	€	€	€	€	GH	€
ë Kí ÖF	€	F	€	€	€	€	€	€	€	I	G	€	€	€	€	HH	€
ë KÖÖF	€	€	€	€	€	€	€	€	€	G	€	€	€	€	€	GJ	€
ë Kí ÖF	€	G	€	€	€	€	€	€	€	FF	€	€	€	€	€	G	€

ÓÚÓÇŠÄÜWÖSÜ

Üä^Ääš ^KÖHÜ| *!äš Ää^äš äšäFÜFäUŠÖäSÖF-E-ÜÖÇF È] ä

ÜçäöÖä^KGÖH ÈÈFG

ÜçäöÄä ^Kí KÈÈÈÄÇF

Üä^ÄÖ| ä^KÈÈÈÈÈÈÈF

Ö| { { ^} öKÖä Ä -Äš } * Ä^äš@

Ö| { { ^} öKÖä ÜÜÈÈ-E-Ä^| { ä äÄ|äš äÄ, ^Äüä] •

Ö| { { ^} öKÖY HÜ^| |ç^ääÖ| ^|ççää

Ö| { { ^} öKY ^ä@:HÜ^| } ^

ÜçäöÄä ^	Üä^äš Ü ^ öÄ ^ } ä				Ü^ ^ ç^ääÖ ^ ççää Y ^ • çä ^ } ä				ÜÜÈÈ-Ä^ { ä äÄ äš äÄ, ^Äüä] P ççä ^ } ä				Ü^ ^ ç^ääÖ ^ ççää Öä çä ^ } ä			
	Š^c	V@^	Üä @	Ü^ä•	Š^c	V@^	Üä @	Ü^ä•	Š^c	V@^	Üä @	Ü^ä•	Š^c	V@^	Üä @	Ü^ä•
È KÈÈÄÇF	€	€	F	€	€	€	F	€	H	€	€	€	€	€		€
È KÍ ÄÇF	€	G	F	€	€	€	€	€	G	€	€	€	€	F	ì	€
È KÍ ÄÇF	€	F	G	€	€	€	€	€	Í	€	€	€	€	€	ì	€
È KÍ ÄÇF	€	€	G	€	€	€	€	€	FÍ	€	€	€	€	€	FF	€
È KÈÈÄÇF	€	€	€	€	€	€	€	€	FH	€	€	€	€	€	ì	€
È KÍ ÄÇF	€	€	€	€	€	€	€	€	FG	€	€	€	€	€	ì	€
È KÈÈÄÇF	€	€	€	€	€	€	€	€	GH	€	€	€	€	€	J	€
È KÍ ÄÇF	€	€	€	€	€	€	€	€	G	€	€	€	F	€	ì	€

UVPÖÜÄÜWÖSÜ

Ü^Ää ^KÖÜ| *!ä Ä^ä ää ääGÜFäUÜSÖäSÖÖFehÜÖT ÖË] ä

ÜäöÖä^KGÖä ääFG

ÜäöÄä ^KFKäEEÄT

ÜäÄÖ| ä^KEEEEEEF

Ö({ (^) ö^KÖä Ä -Ä) * Ä^ää@

Ö({ (^) ö^KÖä Ä -Ä) * Ä^ää@ { ä äÄä äÄ, ^Ää] •

Ö({ (^) ö^KÖä Ä -Ä) * Ä^ää@ { ä äÄä äÄ, ^Ää] •

Ö({ (^) ö^KY Ä^ä@:Ä) *

ÜäöÄä ^	Üä^ä^ Ü ä ä } ä				Ü^ ä^äÖ äää Y ^• ä } ä				ÜÜFÄ^Ä { ä äÄä äÄ, ^Ää] • P ä } ä				Ü^ ä^äÖ äää Öä ä } ä			
	S^c	V@	Üä @	Ü^ä•	S^c	V@	Üä @	Ü^ä•	S^c	V@	Üä @	Ü^ä•	S^c	V@	Üä @	Ü^ä•
€FKÄÄT	€	G	F	€	F	F	€	€	í	€	G	€	G	G	€	€
€FKí ÄT	€	G	F	€	€	€	€	€	l	€	€	€	€	F	G	€
€FKí ÄT	€	G	G	€	G	F	€	€	l	G	í	€	F	F	F	€
€GÄÄT	€	€	€	€	€	F	€	€	í	G	G	€	€	H	€	€
€Gí ÄT	€	€	F	€	F	€	€	€	í	€	F	€	€	€	F	€
€GÄÄT	€	F	€	€	€	í	€	€	í	€	G	€	€	H	€	€
€Gí ÄT	€	€	€	€	€	€	€	€	í	€	l	€	€	F	€	€

ÓÚÓΥΣΑΨΥΩΣÚ

Úá^Ááá ^KÓÁÚ! *!á Áá^*áá áááGÚFáÚÚÓáÓÓFéÚÓÚ Óé] á

ÚááÓáá^KGáá áááFG

ÚááÓáá ^KFKááÁÚT

Úá^ÁÓ! á^Káááááááááá

Ó! { { ^} óáKÓáá Á-Áá} * Á^ááá@

Ó! { { ^} óáKÓáá Á-Áá} * Á^ááá@ { á áá^áá á^Á, ^Ááá] •

Ó! { { ^} óáKÓáá Á-Áá} * Á^ááá@ { á áá^áá á^Á, ^Ááá] •

Ó! { { ^} óáKY ^áá@! Á^Á} •

ÚááÓáá ^	Úá^Ááá Ú! ~ óá[~] á				Ú^] ~ Á^áááÓ! ~ Á^ááá Y ^• óá[~] á				ÚÚÉ-Á^! { á áá^áá á^Á, ^Ááá] • P! !óá[~] á				Ú^] ~ Á^áááÓ! ~ Á^ááá Óááóá[~] á			
	Á^c	V@	Úá @	Ú^á•	Á^c	V@	Úá @	Ú^á•	Á^c	V@	Úá @	Ú^á•	Á^c	V@	Úá @	Ú^á•
€FKááÁÚT	€	€	€	€	€	€	€	€	€	F	€	€	€	€	€	€
€FKí ÁÚT	€	€	€	€	€	F	F	€	€	€	€	€	€	F	€	FH
€FKí ÁÚT	€	€	€	€	€	€	F	€	€	H	€	F	€	€	€	í
€GááÁÚT	€	€	F	€	€	€	€	€	€	H	€	€	€	€	€	í
€Gí ÁÚT	€	F	€	€	€	€	€	€	€	G	€	€	€	F	€	F
€GááÁÚT	€	€	€	€	€	€	€	€	€	G	€	€	€	€	€	í
€Gí ÁÚT	€	€	€	€	€	€	€	€	€	H	€	€	€	€	€	í

ÖÜPVOÖÖÜÄÜWÖSÜ

Ö^Ää ^KÖÜ| *!ä Ä^ä ää ääGÜFäUÖÖÖÖFehÜÖÜT ä
 ÜöÖÖäKÖÖ ÖÖFG
 ÜöÖÖä ^KI KEEÄÜT
 ÜäÄ| ä^KEEEEEFF
 Ö({ ^) öKÖä Ä -Ä|) * Ä^ä@
 Ö({ ^) öKÖBÜÜÜE-E-Ä^!{ ä äÄ|ä äÄ, ^Ää] •
 Ö({ ^) öKÖBY KÜ^| ^ÄäÖ| ^Ää
 Ö({ ^) öKY ^ä@:KÜ}} ^

ÜöÖÖä ^	ÜäÄ Ü öÄ ^) ä				Ü^ ^ÄäÖ ^Ää Y ^• öÄ ^) ä				ÜÜE-E-Ä^!{ ä äÄ ä äÄ, ^Ää] • B öÄ ^) ä				Ü^ ^ÄäÖ ^Ää Öä öÄ ^) ä				
	S^c	V@	Üä @	Ü^ä•	S^c	V@	Üä @	Ü^ä•	S^c	V@	Üä @	Ü^ä•	S^c	V@	Üä @	Ü^ä•	
€ KEEÄÜT	€	€	F	€	€	€	€	€	€	GE	€	€	€	€	€	I	€
€ KÍ ÜT	€	F	G	€	€	€	€	€	€	FH	€	€	€	€	€	F	€
€ KEEÄÜT	€	€	€	€	€	€	€	€	€	Fì	€	F	€	€	€	ì	€
€ KÍ ÜT	€	F	F	€	€	€	€	€	€	FF	F	€	€	F	€	I	€
€ KEEÄÜT	€	€	€	€	€	€	€	€	€	€	€	€	€	€	€	Fì	€
€ KÍ ÜT	€	€	€	€	€	€	€	€	€	I	€	€	€	€	€	J	€
€ KEEÄÜT	€	€	€	€	€	€	€	€	€	I	€	€	€	€	€	G	€
€ KÍ ÜT	€	€	€	€	€	€	€	€	€	ì	€	€	€	€	€	H	€

ÓÚÓΑΣΆΥΨΩΣÚ

Ú^Áαβ ^KÓÁÚ! *!αβ Δαβ ααβΓΔΕΖΗΘΙÚΤ Η] á

Úααδ^Áα^KG@H EFG

Úααδ^Áα ^Kl KEEÁÚT

Úα^ÁÚ! á^KEEEEEEFF

Ó({ (^) δ^KÓαβ Á -Áβ) *^Áααα@

Ó({ (^) δ^KββΔÁÚËË-Á^!{ á αβ@αβ á^Á, ^Áβ] •

Ó({ (^) δ^KÓββ KÁ^! ^!ç^ÁααÓ! ^!çααá

Ó({ (^) δ^KY^αα@!KÁ^!)) ^

Úααδ^Áα ^	Ú!áαα^ Ú! ^ @ [^] á				Ú^! ^!ç^!áααÓ! ^!çααá Y^•α[^] á				ÚËË-Á^!{ á αβ@αβ á^Á, ^Áβ] • β [! @ [^]] á				Ú^! ^!ç^!áααÓ! ^!çααá Óααα [^] á			
	S^c	V@	Úá @	Ú^á•	S^c	V@	Úá @	Ú^á•	S^c	V@	Úá @	Ú^á•	S^c	V@	Úá @	Ú^á•
Ε KEEÁÚT	€	€	€	€	€	€	€	€	HJ	€	€	€	F	€	G	€
Ε KÍ ÁÚT	€	€	€	€	€	€	€	€	H	€	€	€	F	F	H	€
Ε KEEÁÚT	€	€	€	€	€	€	€	€	H	€	€	€	G	€	H	€
Ε KÍ ÁÚT	€	€	F	€	F	€	€	€	G	€	€	€	F	€	H	€
Ε KEEÁÚT	€	€	F	€	€	€	€	€	í	€	€	€	€	€	HG	€
Ε KÍ ÁÚT	€	€	€	€	€	€	€	€	í	€	€	€	€	€	G	€
Ε KEEÁÚT	€	€	€	€	€	€	€	€	í	€	€	€	€	€	GG	€
Ε KÍ ÁÚT	€	€	€	€	F	€	€	€	J	€	€	€	€	F	Fí	€

Intersection Turning Movement

Prepared by:

National Data & Surveying Services

Project ID: CA12_5260_002

Day: MONDAY

City: City of Los Angeles

Totals
AM

Date: 06/11/2012

NS/EW Streets:	Terminal Island Fwy Sb Off-Ramp			Terminal Island Fwy Sb Off-Ramp			New Dock St			New Dock St			TOTAL
	NORTHBOUND			SOUTHBOUND			EASTBOUND			WESTBOUND			
LANES:	NL	NT	NR	SL	ST	SR	EL	ET	ER	WL	WT	WR	
	0	1	0	0	2	0	0	2	1	0	2	0	
7:00 AM	3		0	3	1	50		8	2	1	2		70
7:15 AM	0		1	3	3	34		3	0	0	0		44
7:30 AM	1		1	5	4	32		1	3	0	2		49
7:45 AM	0		2	6	3	26		6	3	0	4		50
8:00 AM	5		2	3	1	14		10	2	0	1		38
8:15 AM	6		2	1	2	22		16	1	0	1		51
8:30 AM	4		1	0	0	19		18	5	1	2		50
8:45 AM	5		2	6	0	26		21	5	1	2		68
TOTAL VOLUMES :	24	0	11	27	14	223	0	83	21	3	14	0	420
APPROACH %'s :	68.57%	0.00%	31.43%	10.23%	5.30%	84.47%	0.00%	79.81%	20.19%	17.65%	82.35%	0.00%	
PEAK HR START TIME :	700 AM												TOTAL
PEAK HR VOL :	4	0	4	17	11	142	0	18	8	1	8	0	213
PEAK HR FACTOR :	0.667			0.787			0.650			0.563			0.761

CONTROL : 1-Way Stop (SB)

Intersection Turning Movement

Prepared by:

National Data & Surveying Services

Project ID: CA12_5260_002

Day: MONDAY

City: City of Los Angeles

Totals
PM

Date: 06/11/2012

NS/EW Streets:	Terminal Island Fwy Sb Off-Ramp			Terminal Island Fwy Sb Off-Ramp			New Dock St			New Dock St			TOTAL
	NORTHBOUND			SOUTHBOUND			EASTBOUND			WESTBOUND			
LANES:	NL	NT	NR	SL	ST	SR	EL	ET	ER	WL	WT	WR	
	0	1	0	0	2	0	0	2	1	0	2	0	
4:00 PM	1		4	0	0	20		46	1		0		72
4:15 PM	1		1	0	0	28		67	2		1		100
4:30 PM	1		0	0	0	29		44	1		0		75
4:45 PM	0		3	2	0	43		53	1		0		102
5:00 PM	6		0	0	2	53		26	3		0		90
5:15 PM	3		3	2	1	48		20	0		0		77
5:30 PM	0		2	2	1	49		13	2		1		70
5:45 PM	0		1	1	0	15		5	1		0		23
TOTAL VOLUMES :	12	0	14	7	4	285	0	274	11	0	2	0	609
APPROACH %'s :	46.15%	0.00%	53.85%	2.36%	1.35%	96.28%	0.00%	96.14%	3.86%	0.00%	100.00%	0.00%	
PEAK HR START TIME :	415 PM												TOTAL
PEAK HR VOL :	8	0	4	2	2	153	0	190	7	0	1	0	367
PEAK HR FACTOR :	0.500			0.714			0.714			0.250			0.900

CONTROL : 1-Way Stop (SB)

Intersection Turning Movement

Prepared by:

National Data & Surveying Services

Project ID: CA12_5260_002

Day: MONDAY

City: City of Los Angeles

PASSENGER VEHICLES

Date: 06/11/2012

AM

NS/EW Streets:	Terminal Island Fwy Sb Off-Ramp			Terminal Island Fwy Sb Off-Ramp			New Dock St			New Dock St			TOTAL
	NORTHBOUND			SOUTHBOUND			EASTBOUND			WESTBOUND			
LANES:	NL	NT	NR	SL	ST	SR	EL	ET	ER	WL	WT	WR	
7:00 AM	2		0	1	1	42		8	2	1	0		57
7:15 AM	0		1	2	2	29		3	0	0	0		37
7:30 AM	0		1	5	3	22		0	2	0	2		35
7:45 AM	0		2	2	0	13		4	3	0	2		26
8:00 AM	4		1	2	1	9		5	1	0	0		23
8:15 AM	1		1	1	1	8		5	1	0	0		18
8:30 AM	3		1	0	0	6		4	3	0	0		17
8:45 AM	2		1	4	0	2		4	2	0	0		15

TOTAL VOLUMES :	NL	NT	NR	SL	ST	SR	EL	ET	ER	WL	WT	WR	TOTAL
APPROACH %'s :	12	0	8	17	8	131	0	33	14	1	4	0	228
	60.00%	0.00%	40.00%	10.90%	5.13%	83.97%	0.00%	70.21%	29.79%	20.00%	80.00%	0.00%	

PEAK HR START TIME :	700 AM												TOTAL
PEAK HR VOL :	2	0	4	10	6	106	0	15	7	1	4	0	155
PEAK HR FACTOR :	0.750			0.693			0.550			0.625			0.680

CONTROL : 1-Way Stop (SB)

8-9 AM	10	0	4	7	2	25	0	18	7	0	0	0
--------	----	---	---	---	---	----	---	----	---	---	---	---

Intersection Turning Movement

Prepared by:

National Data & Surveying Services

Project ID: CA12_5260_002

Day: MONDAY

City: City of Los Angeles

PASSENGER VEHICLES

Date: 06/11/2012

PM

NS/EW Streets:	Terminal Island Fwy Sb Off-Ramp			Terminal Island Fwy Sb Off-Ramp			New Dock St			New Dock St			TOTAL
	NORTHBOUND			SOUTHBOUND			EASTBOUND			WESTBOUND			
LANES:	NL	NT	NR	SL	ST	SR	EL	ET	ER	WL	WT	WR	
4:00 PM	0		3	0	0	3		13	0				19
4:15 PM	0		1	0	0	6		17	0				24
4:30 PM	0		0	0	0	13		16	0				29
4:45 PM	0		3	2	0	28		38	1				72
5:00 PM	3		0	0	0	39		17	0				59
5:15 PM	2		2	1	1	28		17	0				51
5:30 PM	0		2	1	1	20		6	2				32
5:45 PM	0		1	1	0	4		3	1				10
TOTAL VOLUMES :	NL	NT	NR	SL	ST	SR	EL	ET	ER	WL	WT	WR	TOTAL
APPROACH %'s :	5	0	12	5	2	141	0	127	4	0	0	0	296
	29.41%	0.00%	70.59%	3.38%	1.35%	95.27%	0.00%	96.95%	3.05%	#DIV/0!	#DIV/0!	#DIV/0!	
PEAK HR START TIME :	445 PM												TOTAL
PEAK HR VOL :	5	0	7	4	2	115	0	78	3	0	0	0	214
PEAK HR FACTOR :	0.750			0.776			0.519			0.000			0.743

CONTROL : 1-Way Stop (SB)

4-5 PM 0 0 7 2 0 50 0 84 1 0 0 0

Intersection Turning Movement

Prepared by:

National Data & Surveying Services

Project ID: CA12_5260_002

Day: MONDAY

City: City of Los Angeles

CONTAINERS

Date: 06/11/2012

AM

NS/EW Streets:	Terminal Island Fwy Sb Off-Ramp			Terminal Island Fwy Sb Off-Ramp			New Dock St			New Dock St			TOTAL
	NORTHBOUND			SOUTHBOUND			EASTBOUND			WESTBOUND			
LANES:	NL	NT	NR	SL	ST	SR	EL	ET	ER	WL	WT	WR	
	0	1	0	0	2	0	0	2	1	0	2	0	
7:00 AM	0			0		1		0	0		0		1
7:15 AM	0			0		1		0	0		0		1
7:30 AM	0			0		5		0	0		0		5
7:45 AM	0			4		6		1	0		0		11
8:00 AM	1			0		2		1	1		0		5
8:15 AM	1			0		9		4	0		1		15
8:30 AM	0			0		5		8	1		0		14
8:45 AM	1			0		12		2	1		0		16
TOTAL VOLUMES :	3	0	0	4	0	41	0	16	3	0	1	0	68
APPROACH %'s :	100.00%	0.00%	0.00%	8.89%	0.00%	91.11%	0.00%	84.21%	15.79%	0.00%	100.00%	0.00%	
PEAK HR START TIME :	800 AM												TOTAL
PEAK HR VOL :	3	0	0	0	0	28	0	15	3	0	1	0	50
PEAK HR FACTOR :	0.750			0.583			0.500			0.250			0.781

CONTROL : 1-Way Stop (SB)

Intersection Turning Movement

Prepared by:

National Data & Surveying Services

Project ID: CA12_5260_002

Day: MONDAY

City: City of Los Angeles

CONTAINERS

Date: 06/11/2012

PM

NS/EW Streets:	Terminal Island Fwy Sb Off-Ramp			Terminal Island Fwy Sb Off-Ramp			New Dock St			New Dock St			TOTAL
	NORTHBOUND			SOUTHBOUND			EASTBOUND			WESTBOUND			
LANES:	NL	NT	NR	SL	ST	SR	EL	ET	ER	WL	WT	WR	
	0	1	0	0	2	0	0	2	1	0	2	0	
4:00 PM	0			0	0	9		11	0				20
4:15 PM	0			0	0	14		14	0				28
4:30 PM	0			0	0	11		7	1				19
4:45 PM	0			0	0	11		11	0				22
5:00 PM	3			0	2	9		6	2				22
5:15 PM	0			0	0	11		3	0				14
5:30 PM	0			1	0	16		3	0				20
5:45 PM	0			0	0	5		2	0				7

TOTAL VOLUMES :	NL	NT	NR	SL	ST	SR	EL	ET	ER	WL	WT	WR	TOTAL
	3	0	0	1	2	86	0	57	3	0	0	0	152
APPROACH %'s :	100.00%	0.00%	0.00%	1.12%	2.25%	96.63%	0.00%	95.00%	5.00%	#DIV/0!	#DIV/0!	#DIV/0!	

PEAK HR START TIME :	415 PM												TOTAL
PEAK HR VOL :	3	0	0	0	2	45	0	38	3	0	0	0	91
PEAK HR FACTOR :	0.250			0.839			0.732			0.000			0.813

CONTROL : 1-Way Stop (SB)

4-5 PM	0	0	0	0	0	45	0	43	1	0	0	0	0
--------	---	---	---	---	---	----	---	----	---	---	---	---	---

Intersection Turning Movement

Prepared by:

National Data & Surveying Services

Project ID: CA12_5260_002

Day: MONDAY

City: City of Los Angeles

CHASSIS

Date: 06/11/2012

AM

NS/EW Streets:	Terminal Island Fwy Sb Off-Ramp			Terminal Island Fwy Sb Off-Ramp			New Dock St			New Dock St			TOTAL
	NORTHBOUND			SOUTHBOUND			EASTBOUND			WESTBOUND			
LANES:	NL	NT	NR	SL	ST	SR	EL	ET	ER	WL	WT	WR	
	0	1	0	0	2	0	0	2	1	0	2	0	
7:00 AM	0					2		0					2
7:15 AM	0					2		0					2
7:30 AM	0					2		0					2
7:45 AM	0					4		0					4
8:00 AM	0					1		0					1
8:15 AM	0					2		0					2
8:30 AM	0					0		0					0
8:45 AM	1					1		6					8
TOTAL VOLUMES :	1	0	0	0	0	14	0	6	0	0	0	0	21
APPROACH %'s :	100.00%	0.00%	0.00%	0.00%	0.00%	100.00%	0.00%	100.00%	0.00%	#DIV/0!	#DIV/0!	#DIV/0!	
PEAK HR START TIME :	800 AM												TOTAL
PEAK HR VOL :	1	0	0	0	0	4	0	6	0	0	0	0	11
PEAK HR FACTOR :	0.250			0.500			0.250			0.000			0.344

CONTROL : 1-Way Stop (SB)

Intersection Turning Movement

Prepared by:

National Data & Surveying Services

Project ID: CA12_5260_002

Day: MONDAY

City: City of Los Angeles

CHASSIS

Date: 06/11/2012

PM

NS/EW Streets:	Terminal Island Fwy Sb Off-Ramp			Terminal Island Fwy Sb Off-Ramp			New Dock St			New Dock St			TOTAL
	NORTHBOUND			SOUTHBOUND			EASTBOUND			WESTBOUND			
LANES:	NL	NT	NR	SL	ST	SR	EL	ET	ER	WL	WT	WR	
	0	1	0	0	2	0	0	2	1	0	2	0	
4:00 PM			0			5		4	0				9
4:15 PM			0			4		4	0				8
4:30 PM			0			2		1	0				3
4:45 PM			0			0		1	0				1
5:00 PM			0			1		0	1				2
5:15 PM			1			0		0	0				1
5:30 PM			0			2		0	0				2
5:45 PM			0			1		0	0				1
TOTAL VOLUMES :	0	0	1	0	0	15	0	10	1	0	0	0	27
APPROACH %'s :	0.00%	0.00%	100.00%	0.00%	0.00%	100.00%	0.00%	90.91%	9.09%	#DIV/0!	#DIV/0!	#DIV/0!	
PEAK HR START TIME :	400 PM												TOTAL
PEAK HR VOL :	0	0	0	0	0	11	0	10	0	0	0	0	21
PEAK HR FACTOR :	0.000			0.550			0.625			0.000			0.583

CONTROL : 1-Way Stop (SB)

Intersection Turning Movement

Prepared by:

National Data & Surveying Services

Project ID: CA12_5260_002

Day: MONDAY

City: City of Los Angeles

BOBTAILS

Date: 06/11/2012

AM

NS/EW Streets:	Terminal Island Fwy Sb Off-Ramp			Terminal Island Fwy Sb Off-Ramp			New Dock St			New Dock St			TOTAL
	NORTHBOUND			SOUTHBOUND			EASTBOUND			WESTBOUND			
LANES:	NL	NT	NR	SL	ST	SR	EL	ET	ER	WL	WT	WR	
	0	1	0	0	2	0	0	2	1	0	2	0	
7:00 AM	0			2	0	3		0	0				5
7:15 AM	0			0	0	1		0	0				1
7:30 AM	1			0	1	3		0	0				5
7:45 AM	0			0	3	1		0	0				4
8:00 AM	0			0	0	2		0	0				2
8:15 AM	4			0	1	3		3	0				11
8:30 AM	0			0	0	6		4	0				10
8:45 AM	0			1	0	7		5	1				14
TOTAL VOLUMES :	5	0	0	3	5	26	0	12	1	0	0	0	52
APPROACH %'s :	100.00%	0.00%	0.00%	8.82%	14.71%	76.47%	0.00%	92.31%	7.69%	#DIV/0!	#DIV/0!	#DIV/0!	
PEAK HR START TIME :	800 AM												TOTAL
PEAK HR VOL :	4	0	0	1	1	18	0	12	1	0	0	0	37
PEAK HR FACTOR :	0.250			0.625			0.542			0.000			0.661

CONTROL : 1-Way Stop (SB)

Intersection Turning Movement

Prepared by:

National Data & Surveying Services

Project ID: CA12_5260_002

Day: MONDAY

City: City of Los Angeles

BOBTAILS

Date: 06/11/2012

PM

NS/EW Streets:	Terminal Island Fwy Sb Off-Ramp			Terminal Island Fwy Sb Off-Ramp			New Dock St			New Dock St			TOTAL
	NORTHBOUND			SOUTHBOUND			EASTBOUND			WESTBOUND			
LANES:	NL	NT	NR	SL	ST	SR	EL	ET	ER	WL	WT	WR	TOTAL
	0	1	0	0	2	0	0	2	1	0	2	0	
4:00 PM	0		1	0		2		16	1		0		20
4:15 PM	1		0	0		4		29	2		0		36
4:30 PM	1		0	0		1		19	0		0		21
4:45 PM	0		0	0		3		2	0		0		5
5:00 PM	0		0	0		4		1	0		0		5
5:15 PM	0		0	1		6		0	0		0		7
5:30 PM	0		0	0		11		2	0		1		14
5:45 PM	0		0	0		5		0	0		0		5
TOTAL VOLUMES :	2	0	1	1	0	36	0	69	3	0	1	0	113
APPROACH %'s :	66.67%	0.00%	33.33%	2.70%	0.00%	97.30%	0.00%	95.83%	4.17%	0.00%	100.00%	0.00%	
PEAK HR START TIME :	400 PM												TOTAL
PEAK HR VOL :	2	0	1	0	0	10	0	66	3	0	0	0	82
PEAK HR FACTOR :	0.750			0.625			0.556			0.000			0.569

CONTROL : 1-Way Stop (SB)

Ó[~]•ÁM|ããáÁQ&É
 UUÁÓçÁFíí
 Ó[~]•áÁÓçÁGíí
 QíFDGíÉí

Óã Á-Á[~]•Á^ã&@
 ÞDUÁUÜÈí
 ÓEY KÁU&ã ÁÓ[~]•çããÁ^•ã[~]•á
 Y^ã&@:KÁU}}^

Óã Áã ^ KÁÓÓíí UÓY ÇE
 Uã ÁÓ[~]•á KÁEÉÉÉÉÉÉÉÉ
 Uã ÁÓçÁ KÁHÞEFG
 Uã ÁÁ[~]• KÁ

Ó[~]•ÁU|ããáÉUã•^•^ÁK^ÇÁ^•ÁÓ[~]•áÁV^•&•ÁÓ[~]•áÁU|~ÁV^•&•ÁÓ[~]•áÁV^•&•ÁUçÁV^•&•

UãçÁVã ^	ÜÜÈí Ú[~]•çã[~]•á				U&ã ÁÓ[~]•çããá Y^•çã[~]•á Y^•çã[~]•á				ÜÜÈí Þ[~]•çã[~]•á				U&ã ÁÓ[~]•çããá Y^•çã[~]•á Óãçã[~]•á				QçÁV[~]•çã
	Š^•ç	V@~	Üã Ç	Ç[~]•ÉV[~]•çã	Š^•ç	V@~	Üã Ç	Ç[~]•ÉV[~]•çã	Š^•ç	V@~	Üã Ç	Ç[~]•ÉV[~]•çã	Š^•ç	V@~	Üã Ç	Ç[~]•ÉV[~]•çã	
Éí KÉÇÁE	€	FJ	íí	Jí	€	ÇE	J	GJ	€	í	€	í	€	€	€	€	FG
Éí Kí ÁE	€	IH	íí	FÇE	í	Fí	í	HÇE	í	G	€	HG	€	€	€	€	Fí G
Éí Kí ÇE	€	ÇF	íí	JÇE	H	G	FÇE	í F	€	íí	€	íí	€	€	€	€	FJJ
Éí Kí ÁE	€	GG	íí	Jí	í	H	Fí	í H	í	IH	€	íí	€	€	€	€	FJí
V[~]•çã	€	FÉ	GJí	í ÇG	Fí	JJ	HJ	Fí H	J	Fíí	€	Fí H	€	€	€	€	í É
Éí KÉÇÁE	€	GG	íí	í J	í	ÇE	í	HÇE	€	í H	€	í H	€	€	€	€	Fí H
Éí Kí ÁE	€	ÇE	íí	Jí	í	FG	FÇE	G	F	H	€	H	€	€	€	€	Fí í
Éí Kí ÇE	€	ÇF	íí	Jí	í	FJ	FG	Hí	F	í F	€	í G	€	€	€	€	Fí í
Éí Kí ÁE	€	FJ	í F	FÇE	í	G	Fí	íí	G	í J	€	í F	€	€	€	€	FJí
V[~]•çã	€	í G	HÇE	H G	Fí	íí	íí	Fíí	í	Fíí	€	Fí F	€	€	€	€	í ÇE
Ó[~]•áÁV[~]•çã	€	Fíí	í Jí	ííí	H	Fíí	í H	Gí F	FH	HÇE	€	Hí	€	€	€	€	Fí ÇE
Ç[~]•á&ÇÁ	€	ÇÉ	íí É	Á	Fí É	í É	Gí É	Á	HÉ	Jí É	€	Á	€	€	€	€	Á
V[~]•çã	€	Fí É	í ÇE	íí É	ÇE	FÇE	í É	ÇE	ÉÉ	ÇE	€	Gí É	€	€	€	€	Á
Uã•^•^ÁK^ÇÁ^•	€	FÉH	GJ	í ÇG	Fí	íí	íí	Fí J	FG	ÇE	€	Gí F	€	€	€	€	íí
Á ÁUã•^•^ÁK^ÇÁ^•	€	íí É	í ÇE	í Fí É	íí É	í ÇE	íí É	íí É	JÇE	í ÇE	€	í HÉ	€	€	€	€	íí É
Ó[~]•áÁV[~]•çã &•	€	HG	FHG	Fíí	€	Fí	J	Gí	F	í J	€	í ÇE	€	€	€	€	Gí ÇE
Á ÁÓ[~]•çã ÁV[~]•çã &•	€	Fí É	ÇE	ÇE	€	JÉ	FÇE	í É	í É	Gí É	€	Gí	€	€	€	€	Fí É
Óãã ÁU ~ÁV^•&•	€	í	HÇE	Hí	FF	€	€	FF	€	G	€	G	€	€	€	€	í F
Á ÁÓ[~]•çã ÁU ~ÁV^•&•	€	HÉ	í ÇE	í É	HÉ	€	€	HÉ	€	ÇE	€	ÇE	€	€	€	€	HÉ
Ó[~]•çã ÁV[~]•çã &•	€	HÇE	FÇE	Fí ÇE	F	Gí	í	HÇE	€	HÇE	€	HÇE	€	€	€	€	Gí F
Á ÁÓ[~]•çã ÁV[~]•çã &•	€	Fí	ÇE	FJÉ	H	Fí É	í	FF	€	FÇE	€	JÉ	€	€	€	€	Fí É
UçÁVã &•	€	Fí	Fí	HÇE	í	íí	Fí H	í H	€	Fí	€	Fí	€	€	€	€	FFÇE
Á ÁUçÁVã &•	€	í	ÇE	HÉ	Fí É	Gí É	Fí É	Gí É	€	í É	€	í É	€	€	€	€	í É

UãçÁVã ^	ÜÜÈí Ú[~]•çã[~]•á				U&ã ÁÓ[~]•çããá Y^•çã[~]•á Y^•çã[~]•á				ÜÜÈí Þ[~]•çã[~]•á				U&ã ÁÓ[~]•çããá Y^•çã[~]•á Óãçã[~]•á				QçÁV[~]•çã
	Š^•ç	V@~	Üã Ç	Ç[~]•ÉV[~]•çã	Š^•ç	V@~	Üã Ç	Ç[~]•ÉV[~]•çã	Š^•ç	V@~	Üã Ç	Ç[~]•ÉV[~]•çã	Š^•ç	V@~	Üã Ç	Ç[~]•ÉV[~]•çã	
UãçÁVã ^	€	43	77	120	7	Fí	í	HÇE	í	Gí	€	HÇE	€	€	€	€	Fí G
UãçÁVã ^	€	ÇF	í J	JÉ	H	Gí	FÇE	í F	€	68	€	68	€	€	€	€	199
UãçÁVã ^	€	GG	íí	Jí	í	34	14	53	5	í H	€	íí	€	€	€	€	FJJ
UãçÁVã ^	€	GG	íí	í J	í	ÇE	í	HÇE	€	í H	€	í H	€	€	€	€	Fí H
V[~]•çã K[~]•çã ^	€	FÉ	Gí	HJí	FJ	JJ	Hí	Fíí	J	FJG	€	ÇE	€	€	€	€	íí G
Á ÁU[~]•çã V[~]•çã	€	Gí É	í ÇE	Á	FÇE	í HÉ	Gí É	Á	í É	Jí É	€	Á	€	€	€	€	Á
UÞ	€€€	É G	É H	É G	É J	É G	É F	É H	É í	É í	€€€	É HU	€€€	€€€	€€€	€€€	É í

Ó[~}•ÁM|ãããÁQ&É
 UUÁQ|cÁFII
 Ó[!|}ããÁQ&É
 Q|FÁQ|ÉQ|

Óã Á-Á[~}•Á^ã&@
 PÁUÁUÉI
 ÓEY KÁU&ã ÁQ[~}çããÁ Á•cà[~}á
 Y^ã&@:KÁU}}}

Óã Áã ^ KÁÓÓI UÓY ÇE
 Uã ÁQ[ã ^ KÁEÉÉÉÉÉF
 Uãã ÁQã ^ KÁHÉÉÉÉFG
 Uã ÁÁ[KÁG

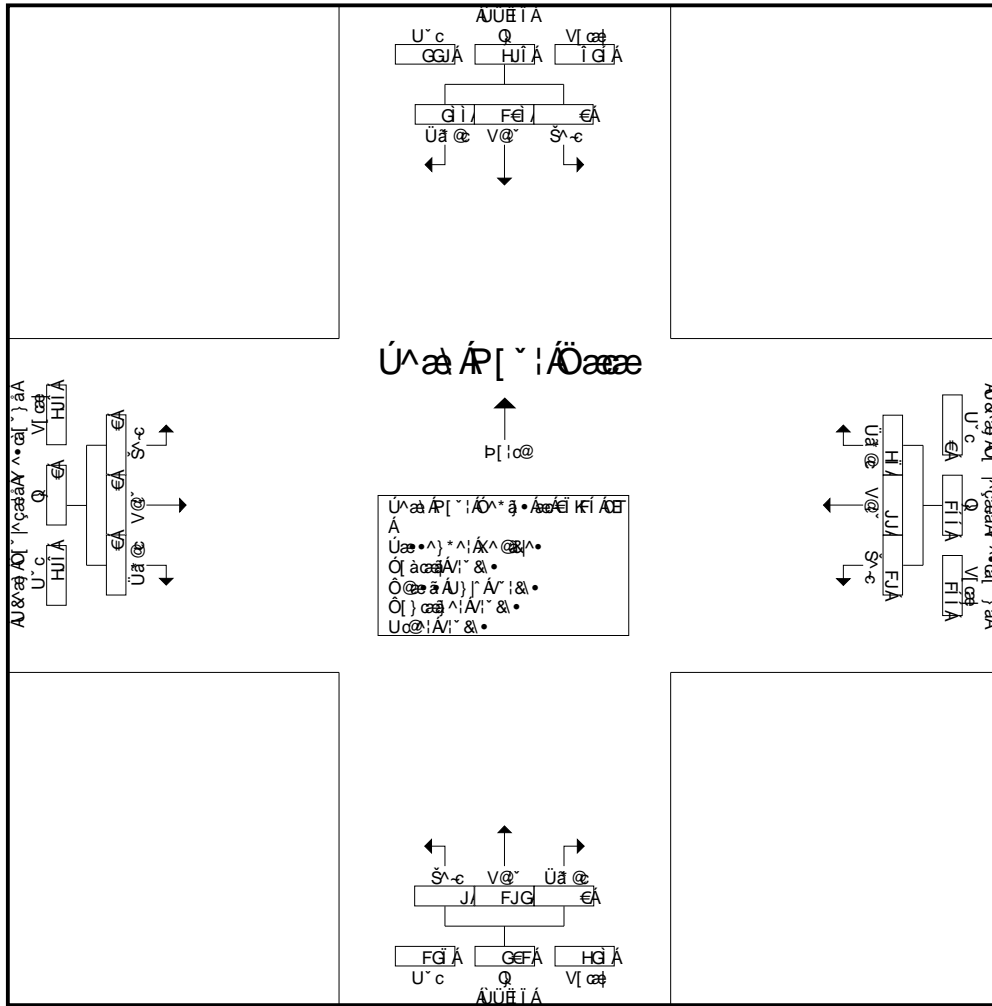

Úã ÁR[~}!ÁÖã&é
 Úã ÁR[~}!ÁÖã&é

	éí kí ÁE				éí kí ÁE				éí kí ÁE				éí kí ÁE			
ÉÉÁ á•É	€	43	77	120	7	Fí	í	HE	l	G	€	HG	€	€	€	€
ÉFí Á á•É	€	GF	íJ	J€	H	G	F€	IF	€	68	€	68	€	€	€	€
ÉHEÁ á•É	€	GG	íí	Jí	í	34	14	53	5	lH	€	íí	€	€	€	€
Éí Á á•É	€	GG	íí	íJ	l	G€	í	HF	€	íH	€	íH	€	€	€	€
V çãK[~}^	€	Fé	Gí	Hí	FJ	JJ	Hí	Fíí	J	FJG	€	GEF	€	€	€	€
Á ÁE ÉV çã	€	GíH	íGé	Á	FGEH	íHE	GHE	Á	íE	JíE	€	Á	€	€	€	Á
UPØ	€€€€	ÉG	ÉH	ÉG	ÉíJ	ÉG	ÉíF	ÉHF	Éí€	Éé	€€€€	ÉHU	€€€€	€€€€	€€€€	€€€€

Ó[~]·ÁM|ā āáÁ&É
 ÚUÁŒ cÁFÍ
 Ó[~]·ÁM|ā āáÁ&É
 QI FDG i È G I

Óā Á-Á[~]·ÁŒā&@
 PÁMÁÚÈÍ
 ÓĒY KÁŒ&āŒ ÁŒ[~]·ÁŒāÁŒ·ā[~]·ā
 Y^ā&@:KÁŒ}}^

ÓĒY ÁŒ^ KÁŒÓÍÍ ÚÓY ŒĒ
 ÚāÁŒ[~]·ÁŒ KÁŒÁŒÁŒÁŒ
 ÚāŒÁŒÁŒ KÁŒÁŒÁŒÁŒ
 ÚāŒÁŒ[~]·ÁŒ KÁŒ

Ó[~]·ÁM|ā āáÁ&É ÚāŒ·ÁŒ^*ÁŒÁŒÁŒ

ÚāŒÁŒ^	ÚŒÈÍ Ú[~]·ā[~]·ā				U&āŒ ÁŒ[~]·ÁŒā Y^·ā[~]·ā Y^·ā[~]·ā				ÚŒÈÍ P[~]·ā[~]·ā				U&āŒ ÁŒ[~]·ÁŒā Y^·ā[~]·ā Œāā[~]·ā				QāŒ[~]·ā
	Š^c	V@~	Ūā@	Œ[~]·ā[~]·ā	Š^c	V@~	Ūā@	Œ[~]·ā[~]·ā	Š^c	V@~	Ūā@	Œ[~]·ā[~]·ā	Š^c	V@~	Ūā@	Œ[~]·ā[~]·ā	
Ē KĒŒŒ	€	FÍ	ÍÍ	Í€	€	FÍ	Í	GH	€	I	€	I	€	€	€	€	JÍ
Ē KÍ ÁŒ	€	HÍ	ÍÍ	JH	G	J	I	FÍ	I	FI	€	FÍ	€	€	€	€	FĜ
Ē KĒŒŒ	€	FI	IJ	ÍH	F	FH	Í	GF	€	IJ	€	IJ	€	€	€	€	FHH
Ē KÍ ÁŒ	€	FG	I€	ÍG	G	GG	F€	H	I	HÍ	€	HU	€	€	€	€	FĜ
V[~]·ā	€	ÍÍ	G€€	GÍ	I	ÍF	G	JH	I	F€G	€	FF€	€	€	€	€	IÍF
Ē KĒŒŒ	€	Í	GH	GJ	I	Í	Í	FÍ	€	HJ	€	HJ	€	€	€	€	ÍH
Ē KÍ ÁŒ	€	I	G	HÍ	H	Í	I	FÍ	F	GG	€	GH	€	€	€	€	ÍÍ
Ē KĒŒŒ	€	Í	GH	GJ	F	Í	Í	FG	F	FJ	€	G€	€	€	€	€	ÍF
Ē KÍ ÁŒ	€	Í	G	H€	G	FF	F€	GH	G	FJ	€	GF	€	€	€	€	ÍÍ
V[~]·ā	€	G	JJ	FG	F€	G	GJ	ÍÍ	I	JJ	€	F€H	€	€	€	€	GJH
Ō:ā áÁ[~]·ā	€	F€H	GJ	I€G	FÍ	ÍÍ	ÍÍ	FÍJ	FG	G€F	€	GFH	€	€	€	€	ÍÍI
Œ[~]·ā&Œ	€	GÍÈ	ÍÍÈ	Á	JÈ	ÍÍÈ	HÍÈ	Á	ÍÈ	JÍÈ	€	Á	€	€	€	€	Á
V[~]·ā	€	F€H	HÍÈ	ÍFÈ	FÈ	FFÈ	ÍÈ	G€È	FÈ	G	€	GÍÈ	€	€	€	€	

ÚāŒÁŒ^	ÚŒÈÍ Ú[~]·ā[~]·ā				U&āŒ ÁŒ[~]·ÁŒā Y^·ā[~]·ā Y^·ā[~]·ā				ÚŒÈÍ P[~]·ā[~]·ā				U&āŒ ÁŒ[~]·ÁŒā Y^·ā[~]·ā Œāā[~]·ā				QāŒ[~]·ā
	Š^c	V@~	Ūā@	Œ[~]·ā[~]·ā	Š^c	V@~	Ūā@	Œ[~]·ā[~]·ā	Š^c	V@~	Ūā@	Œ[~]·ā[~]·ā	Š^c	V@~	Ūā@	Œ[~]·ā[~]·ā	
ÚāŒÁŒ[~]·ÁŒā	€	37	56	93	G	J	I	FÍ	4	FI	€	FÍ	€	€	€	€	FĜ
ÚāŒÁŒ[~]·ÁŒā	€	FI	IJ	ÍH	F	FH	Í	GF	€	49	€	49	€	€	€	€	133
ÚāŒÁŒ[~]·ÁŒā	€	FG	I€	ÍG	G	22	10	34	I	HÍ	€	HU	€	€	€	€	FĜ
ÚāŒÁŒ[~]·ÁŒā	€	Í	GH	GJ	4	Í	Í	FÍ	€	HJ	€	HJ	€	€	€	€	ÍH
V[~]·ā	€	ÍJ	FÍ	GÍ	J	IJ	G	ÍÍ	I	FÍ	€	FÍ	€	€	€	€	ÍÍ
ÁŒ[~]·ā	€	GÍÈ	ÍÍÈ	Á	F€È	ÍÍÈ	HÍÈ	Á	ÍÈ	JÍÈ	€	Á	€	€	€	€	Á
UPØ	€€€	ÈÍÍ	ÈÍ€	ÈHÍ	ÈÍH	ÈÍÍ	ÈÍÍ	ÈG	È€€	ÈJJ	€€€	ÈI€	€€€	€€€	€€€	€€€	ÈÍÍ

Ô[~ } 0 AM ja a na Q&E
 UU A J c AF II
 Ô[! !] z z Ö Ö a G i i
 Q i F D G i E d i

Ôa Á -S [] * A ^ z @
 Ð Ð U Á U É I
 O E Y K Á U & z Å Ö [^ ç z a Á ^ * c a [~ } à
 Y ^ z @ : K Á } } "

Ø Å V a z ^ K S Ö Ö i U Ö Y Ø F
 U a n A Ö j a ^ K E E E E E E F
 U z z a c Ö z a n ^ H Ð B E F G
 U z a ^ Á a [K G

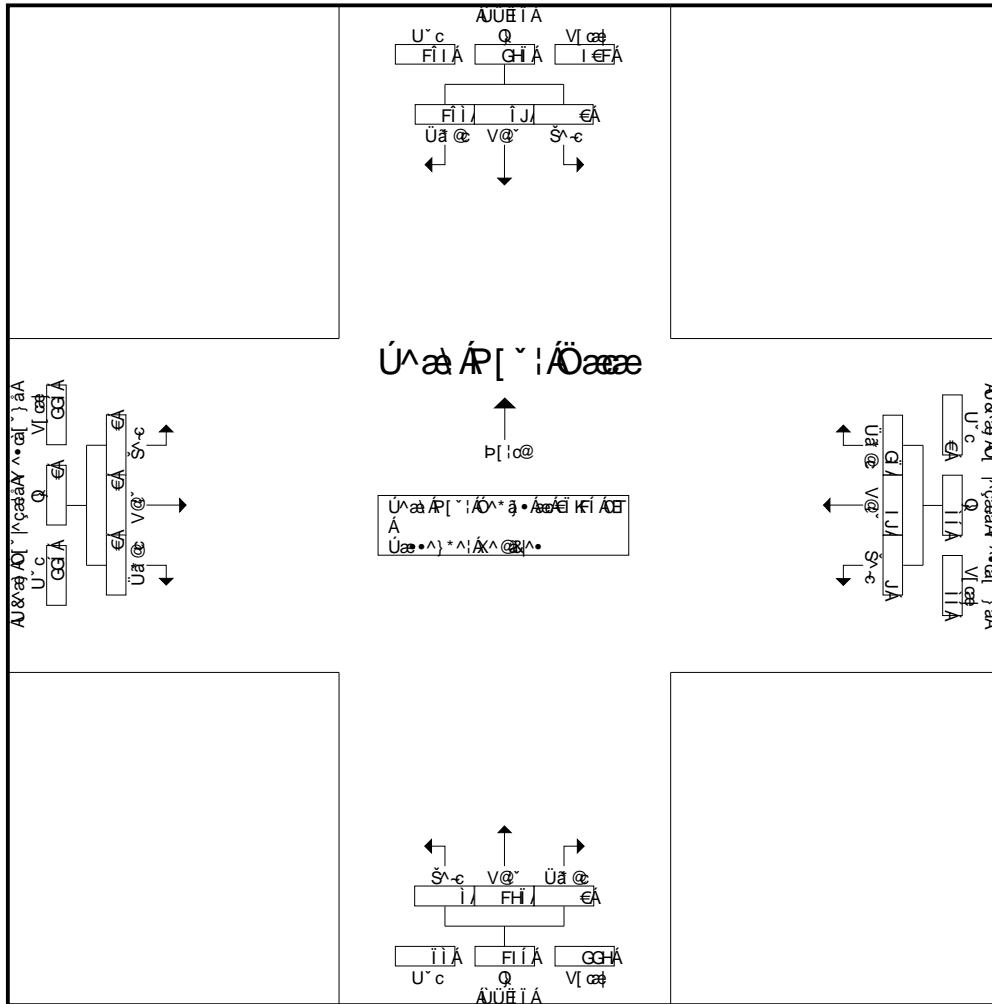

U^z a Á R [^ ! Ö ^ * a ~ Å n ^ K i Á Ø F
 U^z a Á R [^ ! Á ! Ö z a @ n ^ ! z z a @ Ö ^ * a ~ Å n ^ K

	éi Kí ÁØ				éi Kí ÁØ				éi Kí ÁØ				éi Kí ÁØ			
É e Á a · È	€	37	56	93	G	J	I	Fí	4	FÍ	€	Fí	€	€	€	€
É Fí Á a · È	€	FI	IJ	îH	F	FH	ï	GF	€	49	€	49	€	€	€	€
É H e Á a · È	€	FG	I e	íG	G	22	10	34	I	H	€	HJ	€	€	€	€
É I Á a · È	€	î	GH	GJ	4	í	î	Fí	€	HJ	€	HJ	€	€	€	€
Vl œ K [] ^	€	îJ	FíI	GH	J	IJ	G	IÍ	ï	FH	€	FíI	€	€	€	€
Á Å j É Vl œ	€	GJÉ	í e É	Á	F e É	í I É	H F É	Á	í É	J I É	€	Á	€	€	€	€
UPØ	€€€€	É I É	É I É	É H	É I H	É I I	É I I	É G	É € €	É J J	€€€€	É I €	€€€€	€€€€	€€€€	€€€€

Ó[~]•ÁM|ããáQ&É
 ÚUÁÓçÁFÍÍ
 Ó[~]ãÉÓçÁGÍÍ
 QÍFDGÍÉGÍ

Óã Á-Á[~]•Á^ã&@
 ÞÐJÁÚÛËÍ
 ÓÐY KÁÚ&ã ÁÓ[~]çããÁ Á•cà[~]á
 Y^ã&@:KÁ}}^

ÓÐY Áã ^ KÁÓÓÍÍ ÚÓY ÇÞ
 Úã ÁÓ[~]á KÉÉÉÉÉÉÉÉÉ
 Úãç ÁÓã KÁHÞÉÉFG
 Úã ÁÁ[~] KÁ

Ó[~]•ÁÚ:ãçáÉÓ çãÁVÍ~&•

Úãç ÁÁ^	ÚÛËÍ Ú[~]çã[~]á				U&ã ÁÓ[~]çãã Y^•cà[~]á Y^•cà[~]á				ÚÛËÍ Þ[~]çã[~]á				U&ã ÁÓ[~]çãã Y^•cà[~]á Óãçã[~]á				QçÁV[~]çã
	Š~c	V@~	Üã@	Q[~]ÉV[~]çã	Š~c	V@~	Üã@	Q[~]ÉV[~]çã	Š~c	V@~	Üã@	Q[~]ÉV[~]çã	Š~c	V@~	Üã@	Q[~]ÉV[~]çã	
ÉÍ KÉÇÓÞ	€	F	Í	J	€	F	€	F	€	€	€	€	€	€	€	€	F€
ÉÍ KÍ ÁÓÞ	€	F	FF	FG	€	€	€	€	€	J	€	J	€	€	€	€	G€
ÉÍ KÉÇÓÞ	€	H	Í	FF	€	H	F	Í	€	FH	€	FH	€	€	€	€	G
ÉÍ KÍ ÁÓÞ	€	Í	FÍ	FJ	€	H	G	Í	F	Í	€	Í	€	€	€	€	GJ
V[~]çã	€	J	IG	ÍF	€	Í	H	F€	F	G	€	G	€	€	€	€	ÍÍ
ÉÍ KÉÇÓÞ	€	H	FJ	GG	€	F	€	F	€	FG	€	FG	€	€	€	€	HÍ
ÉÍ KÍ ÁÓÞ	€	Í	FJ	G	€	F	F	G	€	€	€	€	€	€	€	€	G
ÉÍ KÉÇÓÞ	€	FF	G	HÍ	€	Í	H	Í	€	FH	€	FH	€	€	€	€	ÍÍ
ÉÍ KÍ ÁÓÞ	€	Í	G	HE	€	H	G	Í	€	FÍ	€	FÍ	€	€	€	€	ÍH
V[~]çã	€	GH	J€	FFH	€	F€	Í	FÍ	€	ÍH	€	ÍH	€	€	€	€	FÍG
Ó!ã áÁV[~]çã	€	HG	FHG	FÍÍ	€	FÍ	J	G	F	ÍJ	€	Í€	€	€	€	€	G€
Q[~]Í&@Á	€	FJÉ	Í€É	Á	€	ÍÍÉ	HÉ	Á	FÉ	JÍÉ	€	Á	€	€	€	€	Á
V[~]çãÁ	€	FGH	Í€É	ÍHÉ	€	ÍÉ	HÉ	F€	€	GÉ	€	GÉ	€	€	€	€	Á

Úãç ÁÁ^	ÚÛËÍ Ú[~]çã[~]á				U&ã ÁÓ[~]çãã Y^•cà[~]á Y^•cà[~]á				ÚÛËÍ Þ[~]çã[~]á				U&ã ÁÓ[~]çãã Y^•cà[~]á Óãçã[~]á				QçÁV[~]çã
	Š~c	V@~	Üã@	Q[~]ÉV[~]çã	Š~c	V@~	Üã@	Q[~]ÉV[~]çã	Š~c	V@~	Üã@	Q[~]ÉV[~]çã	Š~c	V@~	Üã@	Q[~]ÉV[~]çã	
Úãç ÁV[~]çã	€	F	FF	FG	€	€	€	€	€	J	€	J	€	€	€	€	G€
Úãç ÁV[~]çã	€	H	Í	FF	€	3	F	Í	€	13	€	13	€	€	€	€	G
Úãç ÁV[~]çã	€	4	FÍ	FJ	€	H	2	5	€	1	€	1	€	€	€	€	GJ
Úãç ÁV[~]çã	€	H	19	22	€	F	€	F	€	FG	€	FG	€	€	€	€	35
V[~]çãK[~]Í^	€	FF	ÍH	ÍÍ	€	Í	H	F€	F	H	€	HJ	€	€	€	€	FFH
Á ÁÓ[~]ÉV[~]çã	€	FÍÉ	ÍGÉ	Á	€	Í€	HE	Á	GÉ	JÍÉ	€	Á	€	€	€	€	Á
UPØ	€€€	€ÍÍ	€ÉÍ	€G	€€€	€ÍH	€ÍÍ	€€	€G	€ÉHF	€€€	€Í€	€€€	€€€	€€€	€€€	€ÉÍ

Úãç ÁV[~]çã çãã ÁÓ[~]çãã { ÁÍ KÍ ÁÓÞ ÁÍ KÉÇÓÞ ÁÁÚãç ÁÁ-ÁF
 Úãç ÁV[~]çã :ÁÍ ÁÓ[~]çãç!^&çã } ÁÓ^ã • Áã ÁÍ KÍ ÁÓÞ

Ô[~}◦ÁM|ãããÀ&É
 UUÁÔ[çÁFI
 Ô[;|}æÖÖÁGii
 QI FcÁ i È ã i

Ôã Á-Á[~} *Á^æ&
 PÐJAÜÛÈ
 ÔEY KÁU&ã ÁÔ[~} çããÁ Á^çã[~} ã
 Y^æ@;KÁ} } } ^

ÔEY KÁU&ã ÁÔ[~} çããÁ Á^çã[~} ã
 Uã ÁÔ[~} çããÁ Á^çã[~} ã
 Uã ÁÔ[~} çããÁ Á^çã[~} ã
 Uã ÁÔ[~} çããÁ Á^çã[~} ã

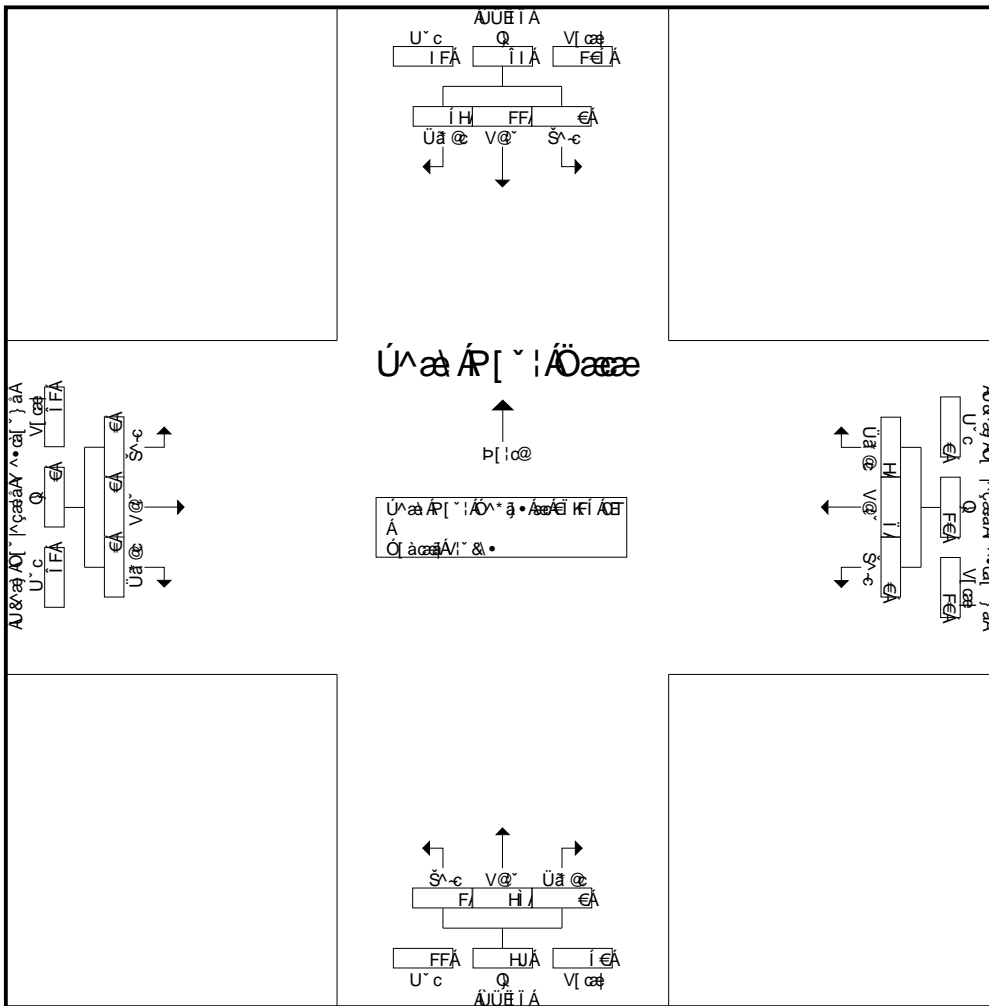

Ú^æÁR[~} ¡Öææ * ÁÔ[~} çããÁ Á^çã[~} ã
 Ú^æÁR[~} ¡Öææ Ô[ãæÁV[~} & • ÁæÁI KI ÁÜ

	éi KI ÁÜ				éi KI ÁÜ				éi KI ÁÜ				éi KI ÁÜ			
ÉcÁ ã •É	€	F	FF	FG	€	€	€	€	€	J	€	J	€	€	€	€
ÉFÁ ã •É	€	H	i	FF	€	3	F	I	€	13	€	13	€	€	€	€
ÉHcÁ ã •É	€	4	FÍ	FJ	€	H	2	5	€	1	€	i	€	€	€	€
ÉIÁ ã •É	€	H	19	22	€	F	€	F	€	FG	€	FG	€	€	€	€
VI çãX[~} { ^	€	FF	íH	íI	€	í	H	F€	€	F	H	€	€	HJ	€	€
Á ÁÖ[~} EÁV[~} çã	€	FÍ	ÈG	íGÈ	€	í	€	H€	€	GÈ	JÍ	€	€	€	€	€
UPØ	ÈÈÈÈ	ÈÈÈÈ	ÈÈÈÈ	ÈÈÈÈ	ÈÈÈÈ	ÈÈÈÈ	ÈÈÈÈ	ÈÈÈÈ	ÈÈÈÈ	ÈÈÈÈ	ÈÈÈÈ	ÈÈÈÈ	ÈÈÈÈ	ÈÈÈÈ	ÈÈÈÈ	ÈÈÈÈ

Ó[] º ÁM |ã ããÁQ&É
 UUÁQ] cÁFII
 Ó[] }ãÖÖÁGII
 QI FÁG I È G I

Óã Á -Á[] * Á^ã&@
 ÞÐJÁUÛÈ I
 ÖEY KÁU&ã ÁQ[] ^çããÁ Á^ãã[] á
 Y ^ã&@:KÁU } } ^

ÖEY Áã ^ KÖÓI i UÓY ÖE
 Uã ÁQ] á^ KEEEEEEF
 UããÁÖã^ KÁHÞEFG
 Uã ^Á[KÁG

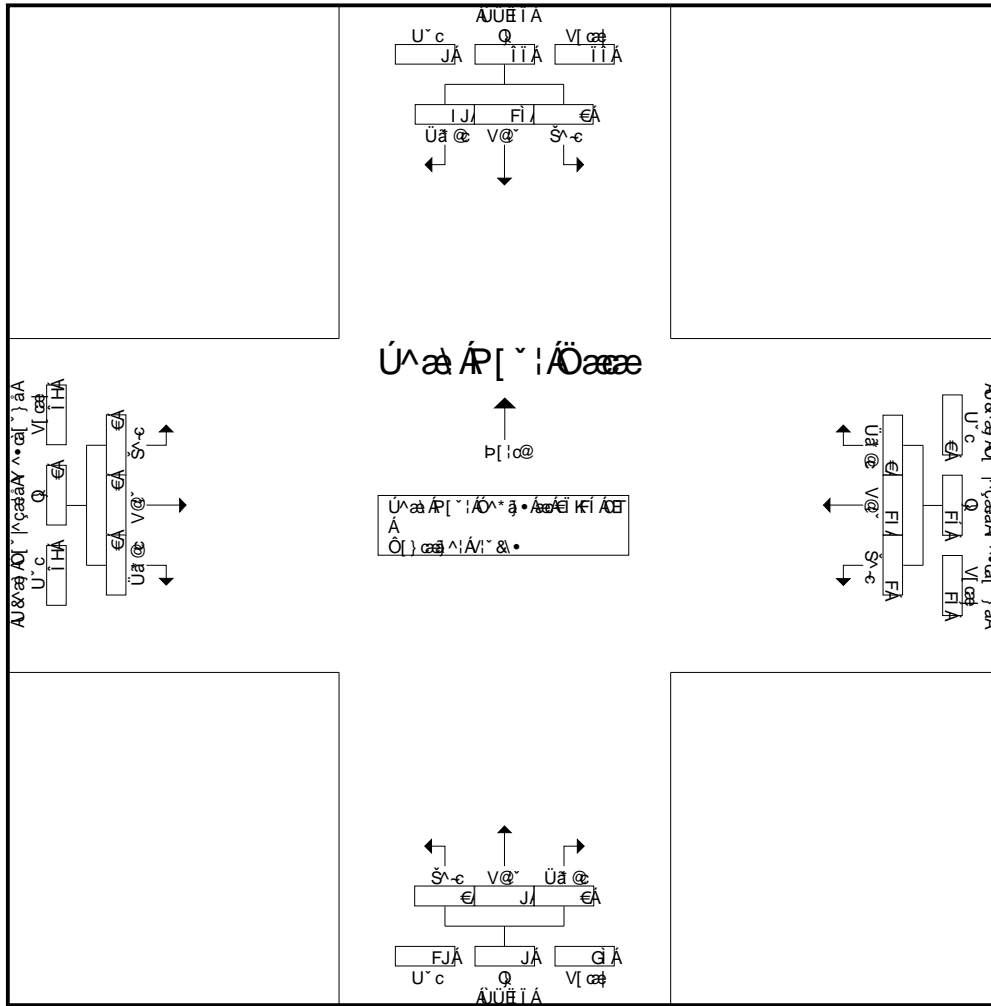

Úã ÁR[] ^ ÁÖãæ * á ÁQ[] { ÁE KÍ ÁÖ Á Á Á KEEÖE ÁU^ã Á Á Á Á
 Úã ÁR[] ^ ÁQ[] Öã ÖE[] }

	EÍ KÍ ÁÖ				EÍ KÍ ÁÖ				EÍ KÍ ÁÖ				EÍ KÍ ÁÖ			
ÉEÁ á·È	€	G	ì	F€	€	F	€	F	€	G	€	G	€	€	€	€
ÉFÁ á·È	€	F	J	F€	€	I	€	I	€	5	€	5	€	€	€	€
ÉHEÁ á·È	€	G	16	Fì	1	I	€	5	€	F	€	F	€	€	€	€
ÉIÁ á·È	€	13	Fì	29	€	5	€	ì	€	F	€	F	€	€	€	€
VI çãK[] ^	€	Fì	IJ	ìì	F	FI	€	Fì	€	J	€	J	€	€	€	€
Á ÁÖ[] EÁVI çã	€	G	È	ìHE	ìÈ	JHEH	€	Á	€	FEE	€	Á	€	€	€	€
UPØ	€€€€	ÈÈ	ÈÈ	ÈÈ	ÈÈ	ÈÈ	ÈÈ€€	ÈÈ	ÈÈ	ÈÈ€€	ÈÈ	ÈÈ€€	ÈÈ	ÈÈ€€	ÈÈ€€	ÈÈ€€

Ö[~]•ÁM|ã ä^áQ&É
 UUÁÖ|çÁFíí
 Ö[~]•áÖÖáGíí
 QíFDGíÉí

Öä: Á-Á[~]•Á^æ&@
 ÞÐJÁUÜÉí
 ÖÉY KÁU&æ[~]•ÁçääÁ^•cá[~]•á
 Y^æ&@:KÁU}}^

ÖÉY Áæ ^ KÖÖÖí UÖY ÖÉ
 Uä:ÁÖ[~]•á KÉÉÉÉÉÉÉÉÉ
 ÜçääÖä: KÁU&æFG
 Üæ^Á[~]•á K&

Ö[~]•ÁU|ã ç^áUç@:Á/í^•&•

ÜçääÁã ^	ÜÜÉí Ú[~]•cá[~]•á				U&æ[~]•ÁÖ[~]•Áçää Y^•cá[~]•á Y^•cá[~]•á				ÜÜÉí P[~]•cá[~]•á				U&æ[~]•ÁÖ[~]•Áçää Y^•cá[~]•á Öæcá[~]•á				QçÁV[~]•cá	
	Š^c	V@~	Üä@	ç[~]•ÉV[~]•cá	Š^c	V@~	Üä@	ç[~]•ÉV[~]•cá	Š^c	V@~	Üä@	ç[~]•ÉV[~]•cá	Š^c	V@~	Üä@	ç[~]•ÉV[~]•cá		
Éí KÉÖÉÉ	€	F	F	G	€	G	G	I	€	€	€	€	€	€	€	€	€	í
Éí Kí ÁÖÉ	€	G	G	I	F	í	G	FÉ	€	H	€	H	€	€	€	€	€	Fí
Éí KÉÖÉÉ	€	H	F	I	G	í	G	FG	€	F	€	F	€	€	€	€	€	Fí
Éí Kí ÁÖÉ	€	I	F	í	G	í	G	J	€	H	€	H	€	€	€	€	€	Fí
V[~]•cá	€	FÉ	í	Fí	í	G	í	Hí	€	í	€	í	€	€	€	€	€	íí
Éí KÉÖÉÉ	€	€	I	I	€	J	F	FÉ	€	F	€	F	€	€	€	€	€	Fí
Éí Kí ÁÖÉ	€	€	F	F	€	í	F	í	€	í	€	í	€	€	€	€	€	FF
Éí KÉÖÉÉ	€	G	H	í	F	í	G	í	€	G	€	G	€	€	€	€	€	Fí
Éí Kí ÁÖÉ	€	H	G	í	€	í	F	í	€	G	€	G	€	€	€	€	€	FG
V[~]•cá	€	í	FÉ	Fí	F	G	í	Gí	€	FÉ	€	FÉ	€	€	€	€	€	íH
Ö[~]•áÁV[~]•cá	€	Fí	Fí	HÉ	í	íí	FH	íH	€	Fí	€	Fí	€	€	€	€	€	FFÉ
ç[~]•á&@	€	í€	í€	Á	JÉ	íJÉ	GÉ	Á	€	FÉ€	€	Á	€	€	€	€	€	Á
V[~]•cá	€	FHÉ	FHÉ	GíH	íÉ	í€	FFÉ	ííH	€	FíÉ	€	FíÉ	€	€	€	€	€	Á

ÜçääÁã ^	ÜÜÉí Ú[~]•cá[~]•á				U&æ[~]•ÁÖ[~]•Áçää Y^•cá[~]•á Y^•cá[~]•á				ÜÜÉí P[~]•cá[~]•á				U&æ[~]•ÁÖ[~]•Áçää Y^•cá[~]•á Öæcá[~]•á				QçÁV[~]•cá	
	Š^c	V@~	Üä@	ç[~]•ÉV[~]•cá	Š^c	V@~	Üä@	ç[~]•ÉV[~]•cá	Š^c	V@~	Üä@	ç[~]•ÉV[~]•cá	Š^c	V@~	Üä@	ç[~]•ÉV[~]•cá		
U^ääÁP[~]•í:ÁÖ[~]•cá^ÁQç^:Á&ç[~]•á	€	G	G	I	F	í	2	FÉ	€	3	€	3	€	€	€	€	€	17
U^ääÁP[~]•í:ÁÖ[~]•cá^ÁQç^:Á&ç[~]•á	€	H	F	I	2	í	G	12	€	F	€	F	€	€	€	€	€	Fí
U^ääÁP[~]•í:ÁÖ[~]•cá^ÁQç^:Á&ç[~]•á	€	4	F	5	G	í	G	J	€	H	€	H	€	€	€	€	€	Fí
U^ääÁP[~]•í:ÁÖ[~]•cá^ÁQç^:Á&ç[~]•á	€	€	4	I	€	9	F	FÉ	€	F	€	F	€	€	€	€	€	Fí
V[~]•cáK[~]•í^	€	J	í	Fí	í	Gí	í	íF	€	í	€	í	€	€	€	€	€	íí
Á ÁÖ[~]•cá	€	íG	ííÉ	Á	FGG	íÉ	FíÉ	Á	€	FÉ€	€	Á	€	€	€	€	€	Á
UPØ	€€€	ÉíH	É€	Éí€	ÉG	Éí	Éíí	Éíí	€€€	Éíí	€€€	Éíí	€€€	€€€	€€€	€€€	€€€	ÉíF

Ó[] } • ÁM|ã.ããÁQ&É
UUÁQ| cÁFIÍ
Ó[]! }ãÖÖÁQíi
Q|FQíÈ í

Óã Á-Á[] *Á^ã&@
FÄJÁÜÈÍ
OBY KÁU&ã ÁQ[] ^çããÁ Á •cà[] à
Y ^ã&@:KÁ } } }

QBY Áã ^ KÖÓÍ I UÓY ÇF
Uã ÁQ[] à KÉÉÉÉÉÉF
Uãc ÁQã KÁH B DEFG
Uã ^Á[] K&

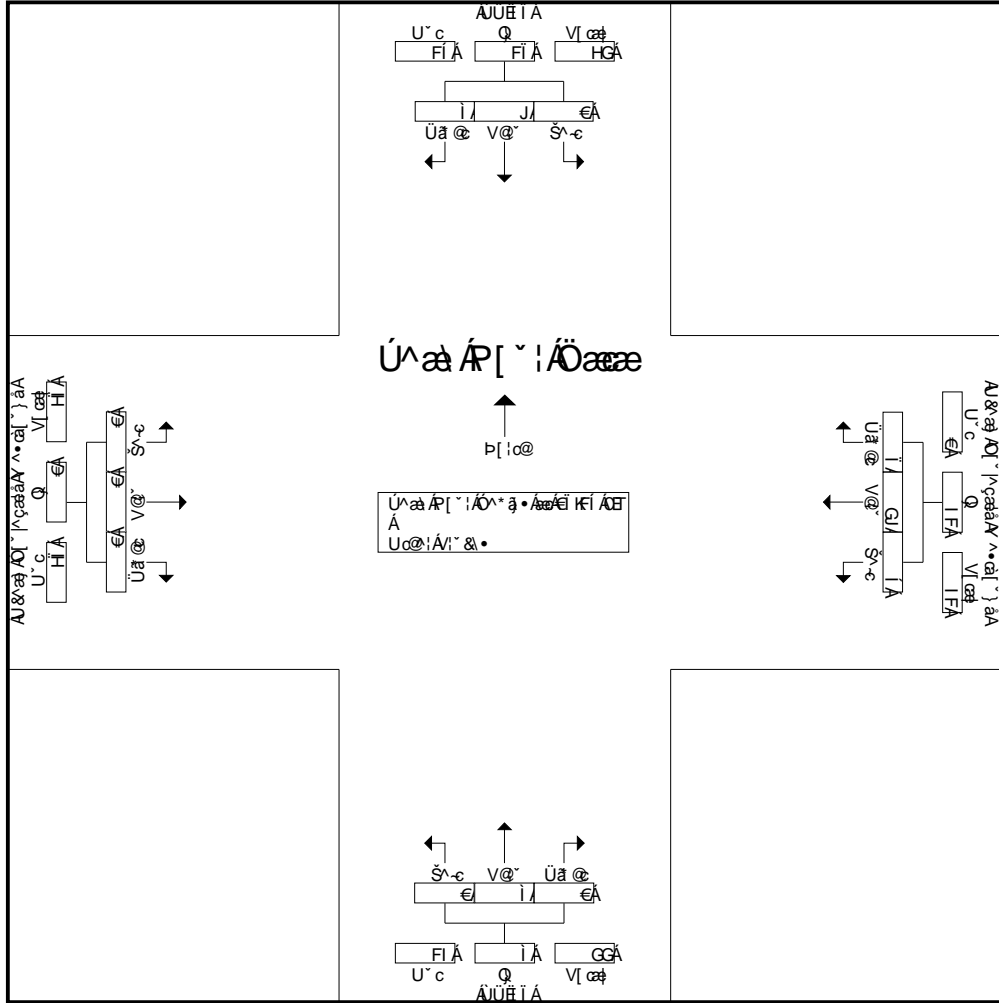

Úã ÁR[] ^ ÁQãã •áÁQ[] { Áí Kí ÁÇ Áí Áí KÉÇ ÁQã ÁU^ã ÁR[] Á
Úã ÁR[] ^ ÁQã Qí!]! }ã ÖÖÁQíi }ã ÖÖÁQíi }ã ÖÖÁQíi }

	Áí Kí ÁÇ	Áí Kí ÁÇ	Áí Kí ÁÇ	Áí Kí ÁÇ	Áí Kí ÁÇ	Áí Kí ÁÇ	Áí Kí ÁÇ	Áí Kí ÁÇ									
ÉÉÁ á •É	€	G	G	I	F	í	2	FE	€	3	€	3	€	€	€	€	
ÉFÍ Á á •É	€	H	F	I	2	í	G	12	€	F	€	F	€	€	€	€	
ÉHÁ á •É	€	4	F	5	G	í	G	J	€	H	€	H	€	€	€	€	
ÉÍ Á á •É	€	€	4	I	€	9	F	FE	€	F	€	F	€	€	€	€	
VI çãK[] { ^	€	J	í	FÍ	í	GJ	í	IF	€	í	€	í	€	€	€	€	
Á ÁQ[] ÁVI çã	€	í	GB	íí È	Á	FG	í è	Fí È	Á	€	FE	€	€	€	€	€	
UPQ	€€€€	ÈíH	È€€	Èí€	ÈG	Èé	Èíí	Èíí	€€€	Èíí	€€€	Èíí	€€€	€€€	€€€	€€€	€€€

Ó{ } , o ÁM ja a a Q & E
U U A O c A F F I
Ó{ } a A O a G i i
Q I F a G i i E d i

Óã Á - Á{ } * Á ^ æ æ @
P H J A U Æ I
O E Y K A U & æ } Á O { } ^ ç a a Á ^ • ç a [] á
Y ^ æ æ @ { K A U } } }

Q Æ Á P a æ ^ K S O O I i U O Y T Ö
U æ Á O j á ^ K E E E E E E F
U ç æ c Ö æ K A H F E D E F G
U æ ^ Á [K G

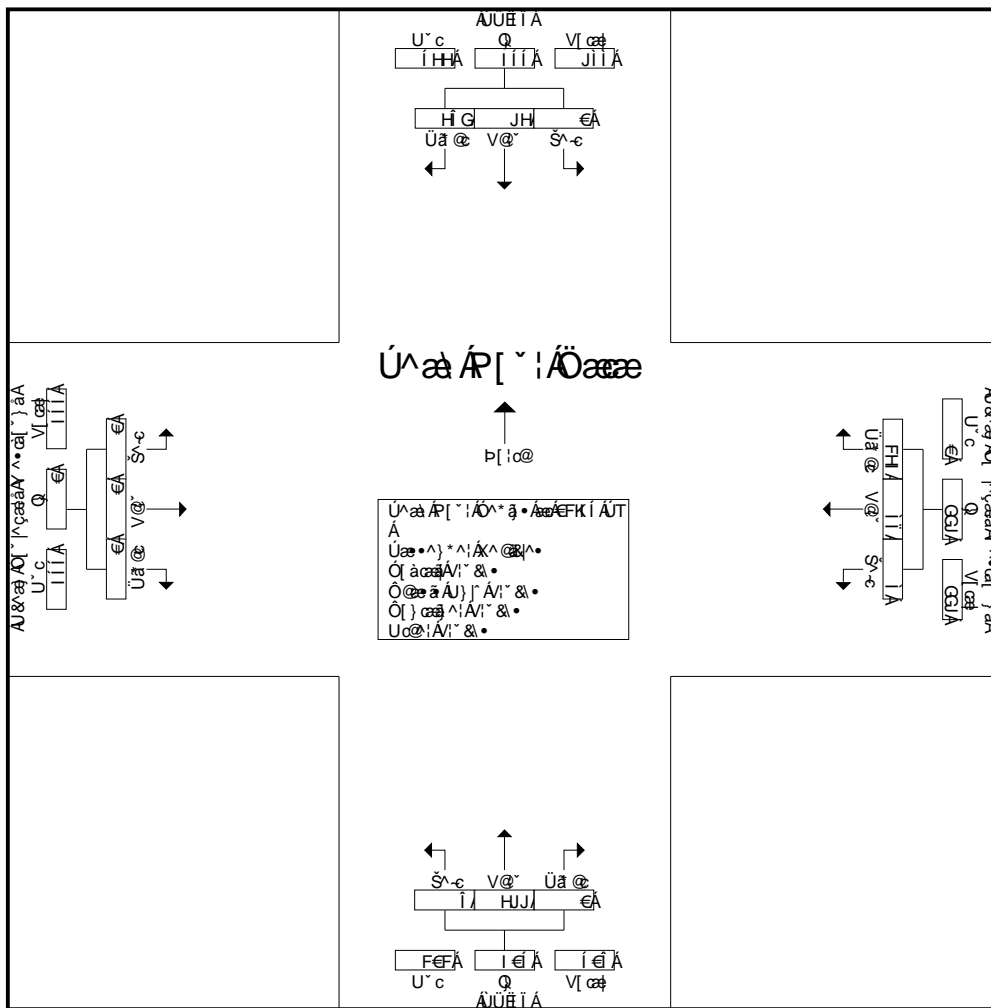

U^æ Á P [] ^ i A O æ æ
U^æ Á P [] ^ i A O æ æ

	efræÚT			efk í ÁÚT				efk í ÁÚT			efræÚT				
É e Ä ä • È	€	G	Ji	F	23	GJ	I H	4	Jí	€	JJ	€	€	€	€
É fí Á ä • È	€	FH	i J	5	GE	42	67	€	Jí	€	Jí	€	€	€	€
É H e Ä ä • È	€	30	106	136	F	GG	G	I J	F	105	€	106	€	€	€
É i í Á ä • È	€	FI	Jí	FF€	F	GG	H	í €	F	F€H	€	F€I	€	€	€
V çæ K [] { ^	€	i H	H i	I í F	i	ii	FH	GGJ	í	HJJ	€	I e Í	€	€	€
Á Á H j Á V çæ	€	Fí È	i GÈ	Á	H È	H i	í i È	Á	FÈ	Ji È	€	€	€	€	Á
U P Ø	€€€	È J G	B í	È í	È €€	B í	È J i	È í i	È í i	B í €	È €€	B í i	È €€€	È €€€	È €€€

Ö[~]•ÁM|ä ä•áQ&É
 UUÁÖ|çÁFíí
 Ö[í]•áÖÖÁGíí
 QíFDGíÉGí

Öä Á-Á[~]•Á^æ@
 ÞDUÁUÜÈí
 ÖEY KÁU&æ ÁÖ[~]•ççääÁ^•cá[~]•á
 Y^æ@:KÁ[~]•}

ÖEY ÁPæ ^ KÖÖÖííUÖYTÖ
 Uä ÁÖ[~]•á KÖÖÖÖÖÖÖÖÖÖ
 UçççÖÖæ KÁHFD&FG
 Uæ^Á[~]• KÁ

Ö[í]•ÁU|ä çääÜæ•^}•^|Á^@Ö[~]•

UçççÁÄ^	ÜÜÈí Ú[~]•cá[~]•}á				U&æ ÁÖ[~]•ççää Y^•cá[~]•}á Y^•cá[~]•}á				ÜÜÈí P[í]•cá[~]•}á				U&æ ÁÖ[~]•ççää Y^•cá[~]•}á Öæ cá[~]•}á				QçÁV[çæ]
	Š^c	V@~	Üä@	Q[í]ÉV[çæ]	Š^c	V@~	Üä@	Q[í]ÉV[çæ]	Š^c	V@~	Üä@	Q[í]ÉV[çæ]	Š^c	V@~	Üä@	Q[í]ÉV[çæ]	
€FKÉÁÜT	€	H	G	G	í	í	J	GG	G	Fí	€	FJ	€	€	€	€	íJ
€FKí ÁÜT	€	J	FJ	G	H	í	J	FJ	€	G	€	G	€	€	€	€	íG
€FKÉÁÜT	€	J	G	HH	G	H	FF	Fí	€	Fí	€	Fí	€	€	€	€	íJ
€FKí ÁÜT	€	í	Fí	G	€	í	í	FF	G	G	€	GH	€	€	€	€	íJ
V[çæ]	€	G	íí	FFí	FF	G	Hí	íí	í	íí	€	íG	€	€	€	€	Gí
€GKÉÁÜT	€	FG	GG	H	H	H	FG	Fí	€	G	€	G	€	€	€	€	í€
€GKí ÁÜT	€	í	G€	G	€	G	FF	FH	F	H	€	H	€	€	€	€	íí
€GKÉÁÜT	€	Fí	HF	íí	F	í	Fí	G	F	GJ	€	H€	€	€	€	€	F€F
€GKí ÁÜT	€	í	G	GJ	F	H	í	J	€	HG	€	HG	€	€	€	€	í€
V[çæ]	€	Hí	Jí	FHí	í	Fí	íí	íí	G	FG	€	FG	€	€	€	€	HGJ
Ö!æ áÁV[çæ]	€	íí	Fí	G€	Fí	Hí	íG	FH	í	G€H	€	G€J	€	€	€	€	íJH
Q[í]•í&@Á	€	Gí	íH€	Á	FF€	Gí	íF€	Á	G€	Jí	€	Á	€	€	€	€	Á
V[çæ]	€	FF€	HF	íG€	G€	í€	FH€	G€	F	Hí	€	Hí	€	€	€	€	Á

UçççÁÄ^	ÜÜÈí Ú[~]•cá[~]•}á				U&æ ÁÖ[~]•ççää Y^•cá[~]•}á Y^•cá[~]•}á				ÜÜÈí P[í]•cá[~]•}á				U&æ ÁÖ[~]•ççää Y^•cá[~]•}á Öæ cá[~]•}á				QçÁV[çæ]
	Š^c	V@~	Üä@	Q[í]ÉV[çæ]	Š^c	V@~	Üä@	Q[í]ÉV[çæ]	Š^c	V@~	Üä@	Q[í]ÉV[çæ]	Š^c	V@~	Üä@	Q[í]ÉV[çæ]	
U^æ ÁP[~]•íÁÖ[çæ]•á ÁÖ[çæ]•á U^æ ÁP[~]•íÁ:ÁÖ[çæ]•á ÁÖ[çæ]•á	€	í	Fí	G	€	í	í	FF	2	G	€	GH	€	€	€	€	íJ
U^æ ÁP[~]•íÁ:ÁÖ[çæ]•á ÁÖ[çæ]•á	€	FG	GG	H	3	H	FG	Fí	€	G	€	G	€	€	€	€	í€
U^æ ÁP[~]•íÁ:ÁÖ[çæ]•á ÁÖ[çæ]•á	€	í	G€	G	€	G	FF	FH	F	36	€	37	€	€	€	€	íí
U^æ ÁP[~]•íÁ:ÁÖ[çæ]•á ÁÖ[çæ]•á	€	14	31	45	F	7	18	26	F	GJ	€	H€	€	€	€	€	101
V[çæ]K[~]•^	€	íF	JF	FHG	í	Fí	íí	íí	í	FFí	€	FFí	€	€	€	€	Hí
Á ÁÖ[çæ]ÉV[çæ]	€	HF€	íí	Á	í	Gí	í€	Á	H€	Jí	€	Á	€	€	€	€	Á
UPØ	€€€	€HG	€H	€HH	€HH	€íF	€íí	€íí	€€€	€JG	€€€	€Jí	€€€	€€€	€€€	€€€	€íí

Ó[~ } o ÁM |ã ãã Q&E
 UUÁO c ÁFII
 Ó[!!] ãã ÖÖÁG ïï
 QI FDÁ ï È ð ï

Óã Á -S[] * Á^æ@
 ÞHUÁUÈ I
 ÖEY KÁU&æ ÁO[~ | çããÁ Á^•cá[~ } á
 Y ^æ@:KÁU } }

QÄ Á Þã ^ KÖÓI ï UÓY T Ö
 Úã ÁO] á^ KEEEEEEF
 Úcã c Öæ K Á B F D E F G
 Úæ ^ Á [K G

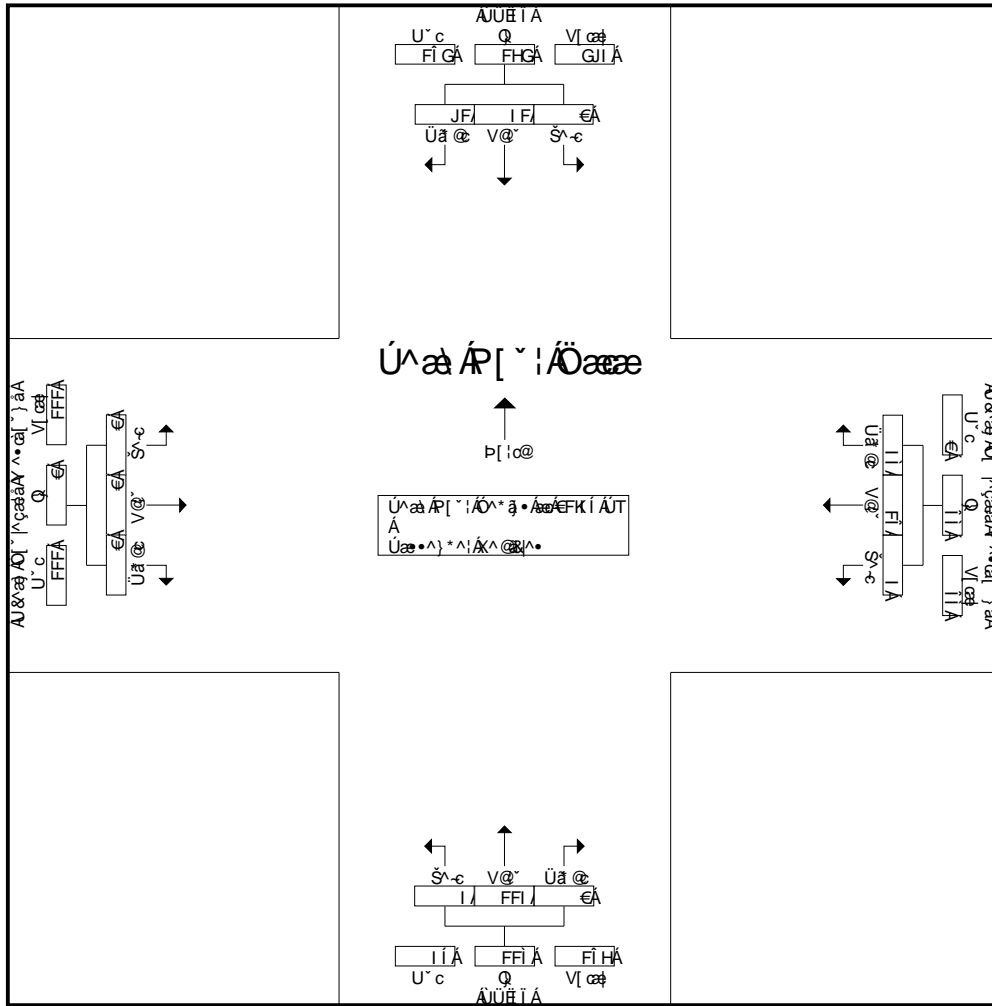

Úæ ÁP[~ | Öææ ÁP[~ | Öææ ÁP[~ | Öææ ÁP[~ | Öææ
 Úæ ÁP[~ | Öææ ÁP[~ | Öææ ÁP[~ | Öææ ÁP[~ | Öææ

	efkí ÁT				efkí ÁT				efkí ÁT				efkí ÁT			
ÉÉ Á á È	€	ï	Fì	G	€	l	ï	FF	2	GF	€	GH	€	€	€	€
ÉFí Á á È	€	FG	GG	H	3	H	FG	Fì	€	G	€	G	€	€	€	€
ÉHE Á á È	€	ì	GE	G	€	G	FF	FH	€	F	36	€	37	€	€	€
ÉÍ Á á È	€	14	31	45	F	7	18	26	F	GJ	€	HE	€	€	€	€
V[cøð K[~ ^	€	IF	JF	FHG	l	Fì	lì	lì	l	FFI	€	FFI	€	€	€	€
Á ÁH] ÉV[cøð	€	HÈ	ì ì È	Á	í È	GÈ	ì È	Á	HÈ	Jí È	€	Á	€	€	€	€
ÚÞØ	€€€	ÈHG	ÈH	ÈHI	ÈHH	ÈÈF	ÈÈì	ÈÈl	ÈÈ€	ÈÈJG	ÈÈ€	ÈÈJ	ÈÈ€€	ÈÈ€€	ÈÈ€€	ÈÈ€€

Ö[~}•ÁM|ãããQ&E
 UUÁÖ|cÁFíí
 Ö[íí]ãÖÖÁGíí
 QíFÁííEíí

Öã Á-Á[~}•Á^æ@
 ÞÖJÁUÜEí
 ÖEY KÁU&æ ÁÖ[~}^çääÁ ^•cà[~}á
 Y^æ@:KÁU}}}

ÖÁVáæ ^ KÖÖÍíUÓY T Ö
 ÚãÁÖ|á^ KEEEEEF
 ÚääcÖæ KÁHDEFG
 Úæ^Á[KÁG

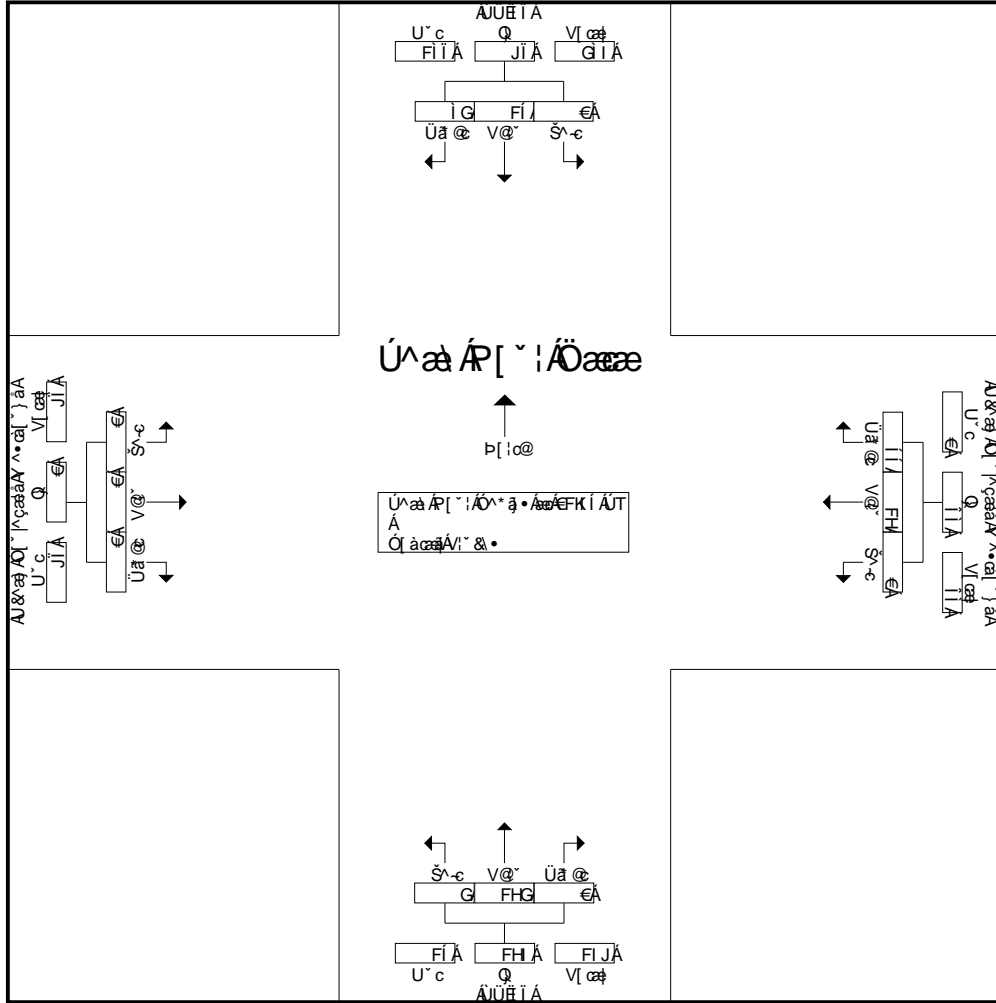

Ú^æ ÁR[~}!Öææ•ÁÁÖ[ííEFKÍ ÁÜT Áí ÁGKÁÜT ÁÜ^æ ÁÁÁ-Á
 Ú^æ ÁR[~}!Áí!ÖææÖ[íí]!ãÖÖ^ã•ÁæK

	EFKÍ ÁÜT		EFKÍ ÁÜT		EFKÍ ÁÜT		EFKÍ ÁÜT
ÉÉÁ á•È	€ í FG Fí	€ F FJ GÉ	2 HH € Hí	€ € € €			
ÉFÍ Á á•È	€ 6 G 33	€ 6 20 26	€ GJ € GJ	€ € € €			
ÉHEÁ á•È	€ G 28 HE	€ í í FH	€ H € H	€ € € €			
ÉÍ Á á•È	€ G Fí Fí	€ F í J	€ 36 € 36	€ € € €			
V çEÁK[~}^	€ Fí íG Jí	€ FH íí íí	G FHG € FH	€ € € €			
Á ÁÖ[íí]V çEÁ	€ FíE ííE Á	€ FJE íE Á	FÉ JíE € Á	€ € € €			
UPÖ	€€€ EíG EíHG EíHí	€€€ EíG Eíí Eíí	Eí€ EíFí EíEE EíHF	EíEE EíEE EíEE EíEE			

Ó[~]·ÁM|ā ā·áQ&É
 ÚUÁŒ cAFÍÍ
 Ó[~]·áÁŒÁGÍÍ
 QIFDÍĒĒÍ

Óā Á-Á[~]·Á^ā&@
 PĒUÁŒÚĒĪ
 ÓĒY ÁŒ&āŒ ÁŒ[~]·Á^āāÁ·ā[~]·ā
 Y^ā&@:ÁŒ[~]·ā

ŒĒÁPāĒ ^ ÁŒÓŒÍÍ ÚŒY T Œ
 ÚāÁŒ[~]·ā ^ ÁŒŒŒŒŒŒŒŒ
 ÚāāŒÓāā ÁŒĒĒĒFG
 Úāā^ÁŒ[~]·ā ĒĒ

ŒŒ[~]·ÁŒā āāĒŒŒāŒ[~]·ÁŒ[~]·ā·

ÚāāŒÁŒ ^	ÚŒĒĪ Ú[~]·ā[~]·ā				U&āŒ ÁŒ[~]·Á^āā Y^·ā[~]·ā Y^·ā[~]·ā				ÚŒĒĪ P[~]·ā[~]·ā				U&āŒ ÁŒ[~]·Á^āā Y^·ā[~]·ā Œāā[~]·ā				QāŒ[~]·ā
	Š^·c	V@~	Ūā @	Œ[~]·ā[~]·ā	Š^·c	V@~	Ūā @	Œ[~]·ā[~]·ā	Š^·c	V@~	Ūā @	Œ[~]·ā[~]·ā	Š^·c	V@~	Ūā @	Œ[~]·ā[~]·ā	
ĒFĒĒÁŒ	€	I	Ī	FF	€	F	€	F	€	G	€	G	€	€	€	€	FI
ĒFĒĪ ÁŒ	€	F€	G	FG	€	F	€	F	€	F	€	F	€	€	€	€	FI
ĒFĒĒÁŒ	€	Ī	Ī	FF	€	G	€	G	€	I	€	I	€	€	€	€	FĪ
ĒFĒĪ ÁŒ	€	Ī	F€	FĪ	€	Ī	€	Ī	€	H	€	H	€	€	€	€	G
V[~]·ā	€	G	G	IJ	€	F€	€	F€	€	F€	€	F€	€	€	€	€	IJ
ĒGĒĒÁŒ	€	I	GH	GĪ	€	I	€	I	€	H	€	H	€	€	€	€	HI
ĒGĒĪ ÁŒ	€	€	FĪ	FĪ	€	F	F	G	€	Ī	€	Ī	€	€	€	€	G
ĒGĒĒÁŒ	€	H	FĪ	FJ	€	Ī	H	Ī	€	Ī	€	Ī	€	€	€	€	HH
ĒGĒĪ ÁŒ	€	F	J	F€	€	H	F	I	€	F	€	F	€	€	€	€	FĪ
V[~]·ā	€	Ī	ĪH	ĪF	€	FH	Ī	FĪ	€	FĪ	€	FĪ	€	€	€	€	FĒ
Œ[~]·ā ÁŒ[~]·ā	€	HG	ĪĪ	FŒ	€	GH	Ī	GĪ	€	GĪ	€	GĪ	€	€	€	€	FĪĪ
Œ[~]·ā & Œ[~]·ā	€	GĒ	ĪĒĒ	Ī	€	ĪGĒ	FĪĒ	Ī	€	F€€	€	Ī	€	€	€	€	Ī
V[~]·ā	€	FĪĒ	ĪĒĒ	ĪĒĒ	€	FĒĒ	GĒ	FĪ	€	FĪĒ	€	FĪĒ	€	€	€	€	Ī

ÚāāŒÁŒ ^	ÚŒĒĪ Ú[~]·ā[~]·ā				U&āŒ ÁŒ[~]·Á^āā Y^·ā[~]·ā Y^·ā[~]·ā				ÚŒĒĪ P[~]·ā[~]·ā				U&āŒ ÁŒ[~]·Á^āā Y^·ā[~]·ā Œāā[~]·ā				QāŒ[~]·ā
	Š^·c	V@~	Ūā @	Œ[~]·ā[~]·ā	Š^·c	V@~	Ūā @	Œ[~]·ā[~]·ā	Š^·c	V@~	Ūā @	Œ[~]·ā[~]·ā	Š^·c	V@~	Ūā @	Œ[~]·ā[~]·ā	
ÚāāŒ[~]·ā	€	5	F€	FĪ	€	6	€	Ī	€	H	€	H	€	€	€	€	G
ÚāāŒ[~]·ā	€	I	23	27	€	I	€	I	€	H	€	H	€	€	€	€	34
ÚāāŒ[~]·ā	€	€	FĪ	FĪ	€	F	F	G	€	7	€	7	€	€	€	€	G
ÚāāŒ[~]·ā	€	H	FĪ	FJ	€	Ī	3	8	€	Ī	€	Ī	€	€	€	€	HH
V[~]·ā	€	FG	ĪĪ	ĪĪ	€	FĪ	I	Œ	€	FJ	€	FJ	€	€	€	€	FFĪ
ĪĪ	€	FĪĒ	ĪĒĒ	Ī	€	Ī	Œ	Ī	€	F€€	€	Ī	€	€	€	€	Ī
UPŒ	€€€	€€€	€Ī	€Ī	€€€	€ĪĪ	€ĒĒ	€Ē	€€€	€ĪJ	€€€	€ĪJ	€€€	€€€	€€€	€€€	€ĪĪ

Ó[] , o ÁM | a a a Q & E
 UUÁO c A F I I
 Ó[] | } a a O Á G I I
 Q I F D G I E G I

Óa Á - Á [] * Á ^ a a @
 P H J A U E I
 O E Y K A U & a Á [] ^ c a a Á ^ * a [] á
 Y ^ a a @ : K A U } }

Q Á P a a ^ K S O O I I U O Y T O
 U a Á O] á ^ K E E E E E E F
 U a a c O a a K A H F D E F G
 U a e ^ Á [K G

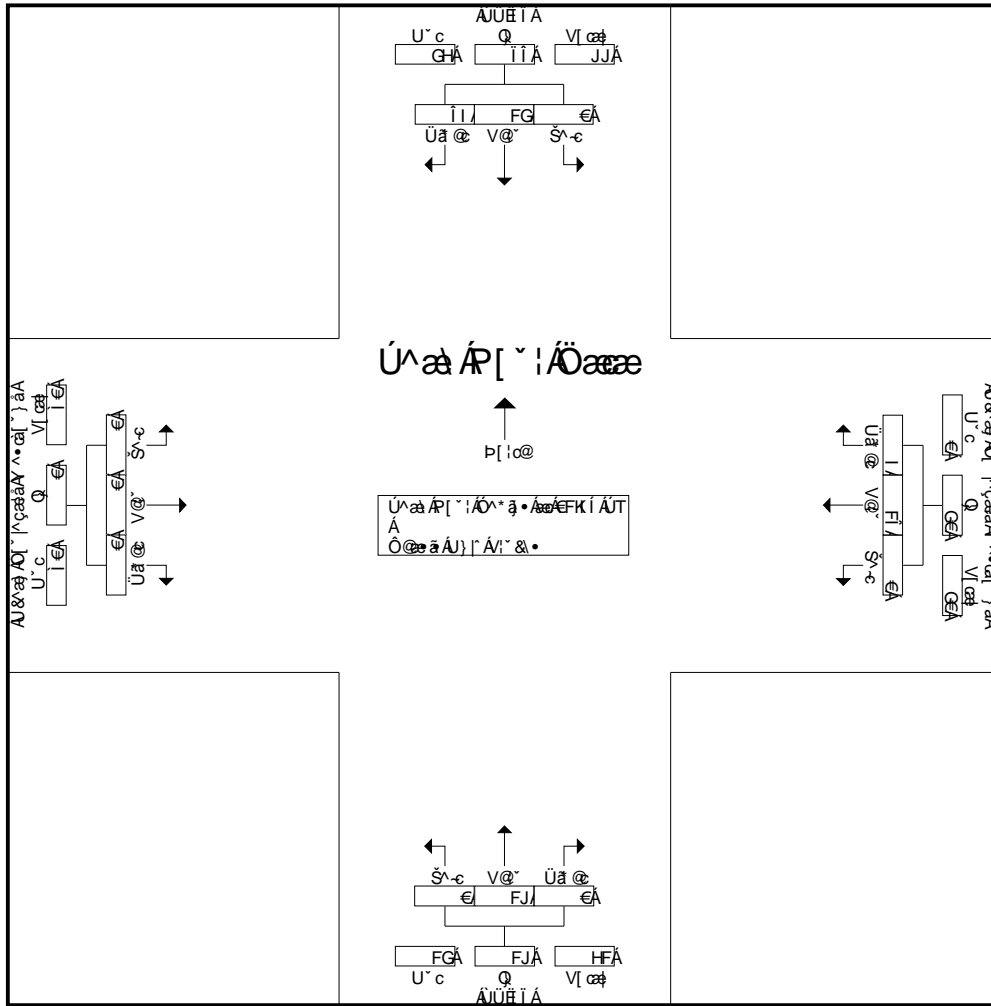

Ú a a Á R [] | Á Ö * á * a Á [] | a A F K I Á Ú T Á F E G K Á Ú T Á U a a Á F Á - Á
 Ú a a Á R [] | Á I : a a O Á G I I | } a a O Á * á * a a K

	EFKÍ ÁÚT				EFKÍ ÁÚT				EFKÍ ÁÚT				EFKÍ ÁÚT			
É e Á á • È	€	5	F€	FÍ	€	6	€	í	€	H	€	H	€	€	€	€
É FÍ Á á • È	€	I	23	27	€	I	€	I	€	H	€	H	€	€	€	€
É H Á á • È	€	€	FÍ	FÍ	€	F	F	G	€	7	€	7	€	€	€	€
É I Á á • È	€	H	FÍ	FJ	€	I	3	8	€	í	€	í	€	€	€	€
V I a a K [] ^	€	FG	í I	í I	€	FÍ	I	G€	€	FJ	€	FJ	€	€	€	€
Á Á H] E V I a a	€	FÍ È	í I È	Á	€	í €	G€	Á	€	F€€	€	Á	€	€	€	€
Ú P Ø	€€€€	È €€	È J I	È €	€€€€	È I I	È H H	È G	€€€€	È I J	€€€€	È I J	€€€€	€€€€	€€€€	€€€€

Ó[~ } , ª Á Y í á à ª Á Q & È
Ù Ú Å Ö ª Á F I Ì
Ô[() ª Å Ö Å G Ì Ì
Q I F D G Ì È G Ì

Ó ª Á À Á[() * Å ^ ª Å @
P D U K Á Ú È Ì
Ô È Y K Á & ª Å Å Ö[~ | ª Ç ª Å Á ^ ª ª [~ } ª
Y ^ ª Å @ : K Á } }

Ç Å Á ª Å ^ K Å Ö Ö I I U Ö Y T Ö
Ú ª Å Ö[ª Å K Å E E E E E E F
Ù ª Å Ö Å Ö ª Å K Å E F D E F G
Ú ª Å ^ Á [K Å

Ô[() * Å Ú á ª Å È Ö[() ª Å ^ Á V I ~ & •

Ù ª Å Ö Å Á ^ Ù[~ ª Å [~ } ª	Ù Ö È Ì Ù[~ ª Å [~ } ª				U & Å Ö[~ ª Ç ª Å Y ^ ª ª [~ } ª Y ^ ª ª [~ } ª				Ù Ö È Ì P [ª Å [~ } ª				U & Å Ö[~ ª Ç ª Å Y ^ ª ª [~ } ª Ö ª Å ª [~ } ª				Q ª Å V[ª Å
	Š ^ - ª	V @ ~	Ü ª @	Ç È V[ª Å	Š ^ - ª	V @ ~	Ü ª @	Ç È V[ª Å	Š ^ - ª	V @ ~	Ü ª @	Ç È V[ª Å	Š ^ - ª	V @ ~	Ü ª @	Ç È V[ª Å	
È F K È Å Ú T	€	I	J	FH	€	I	I	FG	€	FI	€	FI	€	€	€	€	HU
È F K Í Å Ú T	€	F	G	G	€	G	G	G	€	FÈ	€	FÈ	€	€	€	€	HU
È F K È Å Ú T	€	F	FÍ	FÍ	€	Í	FÈ	FÍ	€	FÍ	€	FÍ	€	€	€	€	IJ
È F K Í Å Ú T	€	H	ÈÈ	ÈÈ	€	I	G	Í	€	H	€	H	€	€	€	€	IÌ
V[ª Å	€	J	ÌÌ	ÌÌ	F	FJ	FÍ	HÍ	€	ÌJ	€	ÌJ	€	€	€	€	GÈ
È G K È Å Ú T	€	H	G	G	€	€	J	J	€	H	€	H	€	€	€	€	IÌ
È G K Í Å Ú T	€	G	G	G	€	Í	Í	FG	€	G	€	G	€	€	€	€	IÈ
È G K È Å Ú T	€	FF	I	H	€	I	Í	FG	€	H	€	H	€	€	€	€	JÌ
È G K Í Å Ú T	€	I	H	H	€	H	FÈ	FH	€	G	€	G	€	€	€	€	IÌ
V[ª Å	€	GÈ	FGF	FIF	€	FI	HG	IÌ	€	FFH	€	FFH	€	€	€	€	HÈÈ
Ô[ª Å Á V[ª Å	€	GJ	FJJ	GÈ	F	H	Í	€	€	FJG	€	FJG	€	€	€	€	ÍÈ
Ç () & Å Å	€	FÈÈ	ÌÌÈÈ	Á	FÈÈ	HJÈÈ	ÍJÈÈ	Á	€	FÈÈ	€	Á	€	€	€	€	Á
V[ª Å	€	ÍÈ	HJÈÈ	IÍÈÈ	ÈÈÈ	ÍÈÈ	JÈÈ	FÍÈÈ	€	HÍÈÈ	€	HÍÈÈ	€	€	€	€	

Ù ª Å Ö Å Á ^ Ù[~ ª Å [~ } ª	Ù Ö È Ì Ù[~ ª Å [~ } ª				U & Å Ö[~ ª Ç ª Å Y ^ ª ª [~ } ª Y ^ ª ª [~ } ª				Ù Ö È Ì P [ª Å [~ } ª				U & Å Ö[~ ª Ç ª Å Y ^ ª ª [~ } ª Ö ª Å ª [~ } ª				Q ª Å V[ª Å
	Š ^ - ª	V @ ~	Ü ª @	Ç È V[ª Å	Š ^ - ª	V @ ~	Ü ª @	Ç È V[ª Å	Š ^ - ª	V @ ~	Ü ª @	Ç È V[ª Å	Š ^ - ª	V @ ~	Ü ª @	Ç È V[ª Å	
Ù ª Å Á V[~ Å Ö[ª Å ª Å Ö[({ È F K Í Å Ú T Å È G K È Å Ú T Å Å Ú ª Å Á Á Á F	€	FJ	FFI	FH	€	FÍ	G	HJ	€	FÈ	€	Á	€	€	€	€	HÈH
Ù ª Å Á V[~ Å Ö[ª Å (Å Á Ö[ª Å ^ ª ª } Å Ö[ª Å * Å Å Å È F K Í Å Ú T	€	FHÈ	ÌÌÈÈ	Á	€	HÍÈÈ	ÍFÈÈ	Á	€	FÈÈ	€	Á	€	€	€	€	Á
U P Ø	ÈÈÈÈ	ÈÈHG	ÈÈÌÌ	ÈÈH	ÈÈÈÈ	ÈÈH	ÈÈÌÌ	ÈÈFH	ÈÈÈÈ	ÈÈH	ÈÈÈÈ	ÈÈH	ÈÈÈÈ	ÈÈÈÈ	ÈÈÈÈ	ÈÈÈÈ	ÈÈÈÈ

Ó[~]oAM|ãããQ&E
 UUÁ]cAFÍI
 Ó[!]ãããGÍI
 QI FÁ]í È ð

Óã Á -S[] *Á^æ@
 ÐÞJÁUËÍ
 ÖY KÁ&æ ÁÓ[~|çããÁ^•cà[~] á
 Y^æ@:KÁ}}}

QÁ^ãã ^ KÖÓÍ I UÓY T Ö
 Úã ÁÓ] á^ KEEEEEEF
 ÚããcÖæ KÁÞÞEFG
 Úæ^Á[KÁG

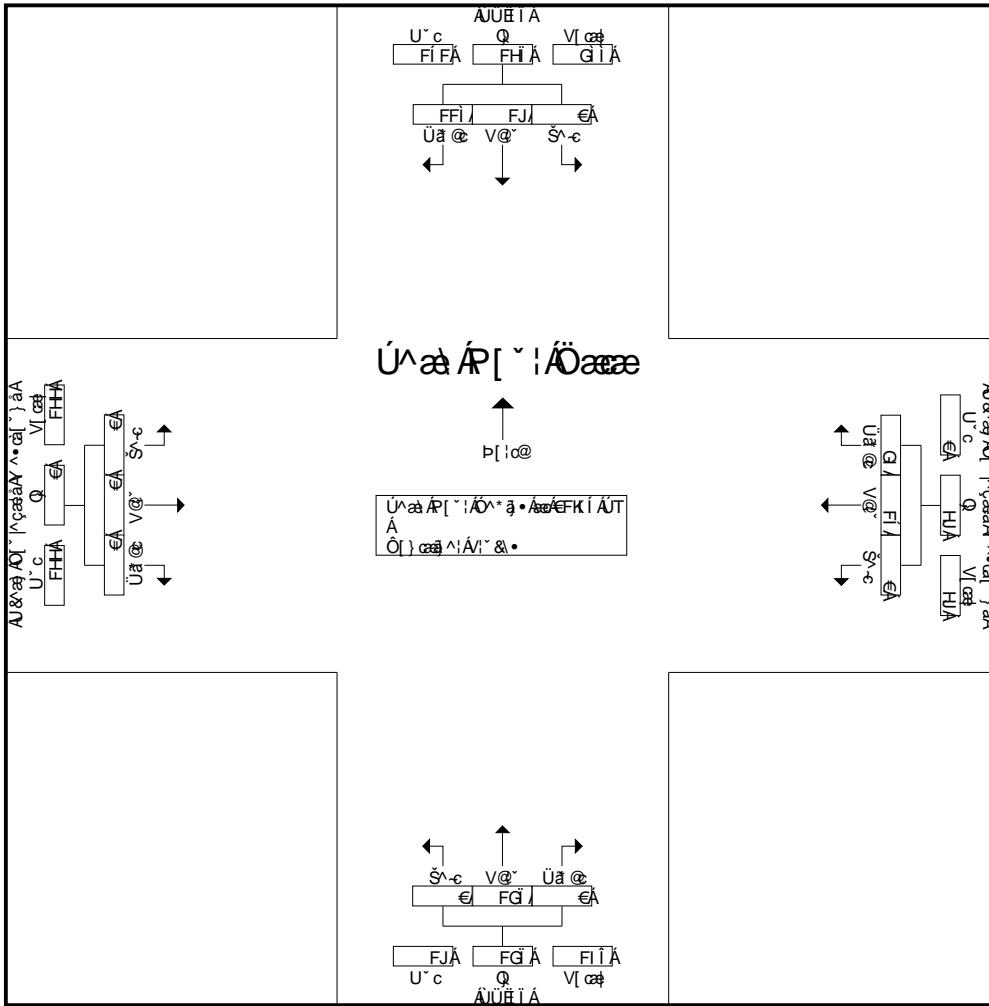

Ú^æ ÁR[~|Öææ] ÁR[~|Öææ] ÁR[~|Öææ] ÁR[~|Öææ] ÁR[~|Öææ] ÁR[~|Öææ]
 Ú^æ ÁR[~|Öææ] ÁR[~|Öææ] ÁR[~|Öææ] ÁR[~|Öææ] ÁR[~|Öææ] ÁR[~|Öææ]

	efkí ÁT				efkí ÁT				efkí ÁT				efkí ÁT			
ÉÉá á•È	€	H	HÉ	HH	€	I	G	Í	€	38	€	38	€	€	€	€
ÉFí Á á•È	€	H	GF	G	€	€	9	J	€	HH	€	HH	€	€	€	€
ÉHÉ á á•È	€	G	G	á	€	7	í	12	€	G	€	G	€	€	€	€
ÉÍ Á á•È	€	11	43	54	€	I	i	FG	€	HF	€	HF	€	€	€	€
V[çã]K[~ ^	€	FJ	FFI	FHí	€	Fí	G	HJ	€	FG	€	FG	€	€	€	€
Á ÁH] ÉV[çã]	€	FHÉ	ííÉ	Á	€	Hí	ííÉ	Á	€	FEE	€	Á	€	€	€	€
UPÖ	€€€	ÈHG	Èíí	ÈH	€€€	ÈHí	Èíí	ÈFH	€€€	ÈH	€€€	ÈHí	€€€	€€€	€€€	€€€

Ó[~}•ÁM]á•á•Á•É
 UUÁ]•Á•F•I
 Ó[!:]•á•Á•G•I
 Q]•F•Á•I•É•I

Ó•Á•Á•Á•}•*•Á•Á•á•@
 P•H•K•U•Ü•É•I
 Ó•E•Y•K•U•&•á•Á•[•~•|•ç•á•Á•^•••á•[•~}•á
 Y•^•á•@•!•K•U•}•}•}

Ó•Á•Á•á•^•K•S•Ó•I•I•U•Ó•Y•Ü•T
 U•á•Á•[•á•^•K•E•E•E•E•E•E•E•F
 U•á•Á•[•Á•á•^•K•H•F•E•F•G
 U•á•^•Á•[•K•G

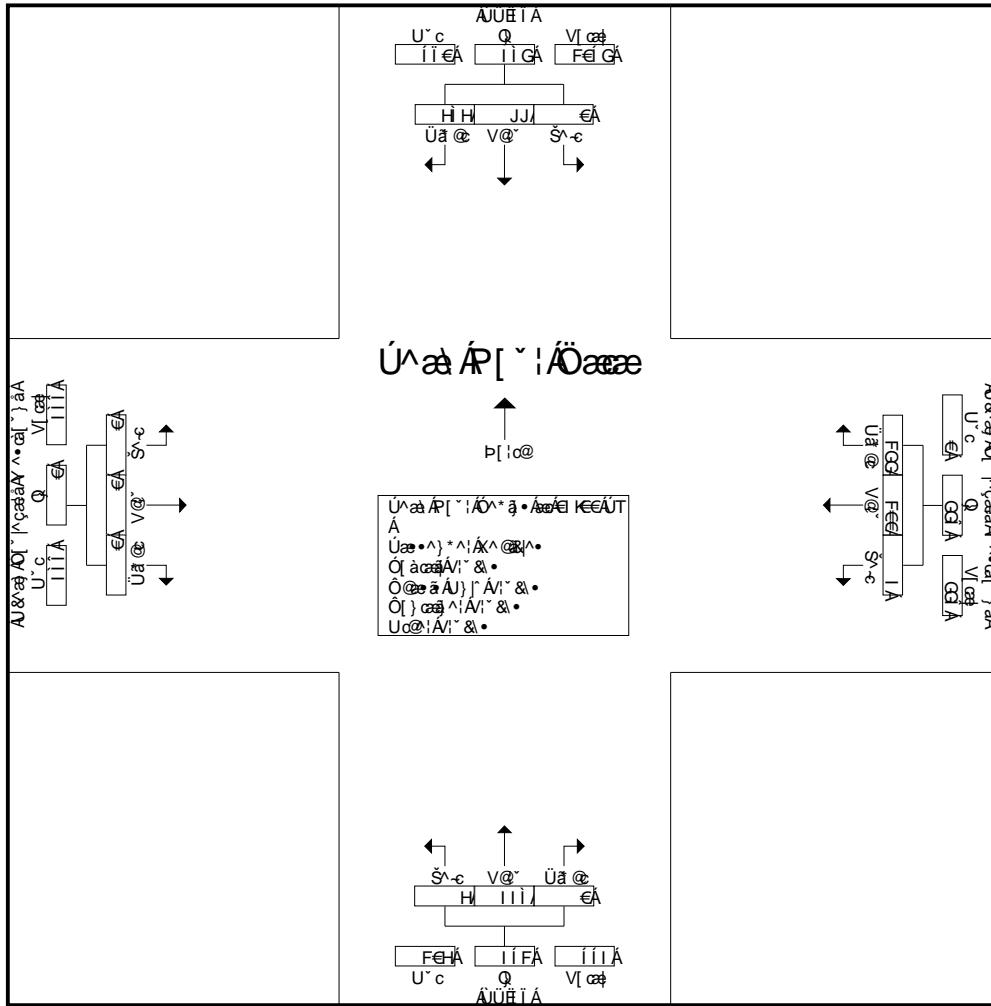

Ú•á•Á•[•~•|•Á•Ö•á•á•E
 Ú•á•Á•[•~•|•Á•Ö•á•á•E

	ei KEÄÜT				ei KEÄÜT				ei KEÄÜT				ei KEÄÜT			
É•É•Á•á•É	€	GH	FEF	FG	F	G€	GJ	í€	1	142	€	143	€	€	€	€
É•F•I•Á•á•É	€	HJ	115	154	2	G	G	í	€	F•H•H	€	F•H•H	€	€	€	€
É•H•É•Á•á•É	€	HJ	F•É	F•I	€	GH	G	í•F	F	J•I	€	J•I	€	€	€	€
É•I•I•Á•á•É	€	48	J•€	F•H	F	31	38	70	F	I•J	€	I•€	€	€	€	€
V]•á•K[~• •^	€	F•I•J	I•F•G	I•I•F	I	F•€€	F•G•G	G•G	H	I•I	€	I•I•F	€	€	€	€
Á•Á•H]•Á•V]•á•	€	G•É	I•H•É	Á	F•É	I•I•G	I•I	Á	€	J•J•H	€	€	€	€	€	€
Ü•P•Ö	€€€€	É•I	É•J	É•F•F	É•€€	É•€	É•H	É•€	É•I•€	É•I•J	€€€€	É•I	€€€€	€€€€	€€€€	€€€€

Ó[~]•ÁM|ããáQ&É
 ÚUÁÓçÁFÍÍ
 Ó[~]ãÁÓçÁGÍÍ
 QÍFDGÍÈGÍ

Óã Á-Á[~]•Á^ã&@
 ÞÐJÁÚËÍ
 ÓÐY KÁ&ã ÁÓ[~]çããÁ Á•cá[~]á
 Y Áã&@:KÁ}}^

Óã Áã Á KÁÓÓÍÍ UÓY ÚT
 Úã ÁÓ[~]á KÁÉÉÉÉÉÉÉÉ
 ÚãçÁÓã KÁHÞBÉFG
 Úã ÁÁ[~] KÁ

Ó[~]•ÁU|ããáÉÚã•^}•^:Á^@Á^•

ÚãçÁÁ^	ÚÛËÍ Ú[~]cá[~]á				U&ã ÁÓ[~]çããá Y Á•cá[~]á Y Á•cá[~]á				ÚÛËÍ P[~]cá[~]á				U&ã ÁÓ[~]çããá Y Á•cá[~]á Óãçá[~]á				QçÁV[~]çá
	Š-c	V@~	Üã@	Qç ÉV[~]çá	Š-c	V@~	Üã@	Qç ÉV[~]çá	Š-c	V@~	Üã@	Qç ÉV[~]çá	Š-c	V@~	Üã@	Qç ÉV[~]çá	
É KÉÁÚT	€	Í	HJ	ÍÍ	€	Í	FÍ	GH	€	ÍÍ	€	ÍÍ	€	€	€	€	FFÍ
É KÍ ÁÚT	€	FJ	I€	ÍJ	€	FF	FÍ	GÍ	€	IJ	€	IJ	€	€	€	€	FHÍ
É KÉÁÚT	€	FÍ	ÍF	ÍÍ	€	FÍ	FÍ	H€	€	IJ	€	Í€	€	€	€	€	FÍÍ
É KÍ ÁÚT	€	GÍ	ÍÍ	ÍH	€	FÍ	GJ	ÍÍ	€	ÍF	€	ÍG	€	€	€	€	FJG
V[~]çá	€	ÍÍ	FÍÍ	GÍH	€	ÍG	ÍÍ	FGÍ	€	G	€	€	€	€	€	€	ÍÍJ
É KÉÁÚT	€	H€	IJ	ÍJ	€	FH	FJ	HÍ	€	ÍÍ	€	ÍÍ	€	€	€	€	FÍÍ
É KÍ ÁÚT	€	GÍ	HJ	ÍÍ	€	J	G€	GJ	€	H	€	H	€	€	€	€	FGJ
É KÉÁÚT	€	Í	H€	HÍ	€	FF	FH	G	€	G€	€	G€	€	€	€	€	ÍF
É KÍ ÁÚT	€	Í	H€	HÍ	€	F	Í	H	€	F	€	G	€	€	€	€	ÍÍ
V[~]çá	€	Í€	FÍJ	GÍJ	€	H	ÍÍ	JÍ	€	F	€	FHÍ	€	€	€	€	ÍÍÍ
Ó!ãáÁV[~]çá	€	FHÍ	HÍ	ÍÍG	€	Í	JF	FHE	€	H	€	HÍ	€	€	€	€	F€H
Qç :á&@Á	€	GÍÈ	ÍFÈG	Á	€	G€	ÍÈH	ÍÍÈ	€	€	€	JJÈ	€	€	€	€	Á
V[~]çá	€	FH	H€G	ÍÍÈ	€	È	ÍÈ	FGÈ	€	€	€	HÈÈ	€	€	€	€	Á

ÚãçÁÁ^	ÚÛËÍ Ú[~]cá[~]á				U&ã ÁÓ[~]çããá Y Á•cá[~]á Y Á•cá[~]á				ÚÛËÍ P[~]cá[~]á				U&ã ÁÓ[~]çããá Y Á•cá[~]á Óãçá[~]á				QçÁV[~]çá
	Š-c	V@~	Üã@	Qç ÉV[~]çá	Š-c	V@~	Üã@	Qç ÉV[~]çá	Š-c	V@~	Üã@	Qç ÉV[~]çá	Š-c	V@~	Üã@	Qç ÉV[~]çá	
ÚãçÁÁ^	€	Í	HJ	ÍÍ	€	Í	FÍ	GH	€	ÍÍ	€	ÍÍ	€	€	€	€	FFÍ
ÚãçÁÁ^	€	FJ	I€	ÍJ	€	FF	FÍ	GÍ	€	IJ	€	IJ	€	€	€	€	FHÍ
ÚãçÁÁ^	€	FÍ	ÍF	ÍÍ	€	FÍ	FÍ	H€	€	IJ	€	Í€	€	€	€	€	FÍÍ
ÚãçÁÁ^	€	26	57	83	€	18	29	47	€	F	€	61	€	€	€	€	192
V[~]çá	€	ÍÍ	FÍÍ	GÍH	€	ÍG	ÍÍ	FGÍ	€	G	€	€	€	€	€	€	ÍÍJ
Á ÁÓ[~]ÉV[~]çá	€	GÍÈ	ÍHÈ	Á	€	È	ÍÈ	ÍÍÈ	€	F	€	JJ	€	€	€	€	Á
UPØ	€€€	ÈH	ÈG€	ÈÍG	€€	ÈGG	ÈÍÍ	ÈÍF	€€€	ÈÍÍ	€€€	ÈHU	€€€	€€€	€€€	€€€	ÈÍÍ

ÚãçÁÁ^:ÁÓ[~]çããá•ÁÁÓ[~]çããá{ÁÍ KÉÁÚT ÁÍ KÍ ÁÚT ÁÁÚã ÁÁÁ-Á

ÚãçÁÁ^:ÁÍ:ÁÓ[~]çããá•ÁÁÓ[~]çããá}ÁÓ[~]çããá•ÁÁÁ KÉÁÚT

Ó[} , o ÁM | á a a Q & E
 UU A O c A F I I
 Ó [! | } a a O a G I i
 Q I F D a I E G i

Ó a Á - Á [} * A ^ a a @
 P H I A U Ü E I
 O E Y K A U & a a A O [^ | ^ ç a a A ^ * a a [^ } á
 Y ^ a a @ : I K A U } } }

Q a A a a ^ K S O O I I U O Y U T
 U a A O [a ^ K E E E E E E F
 U a a O a a K A H F D E F G
 U a a A [K G

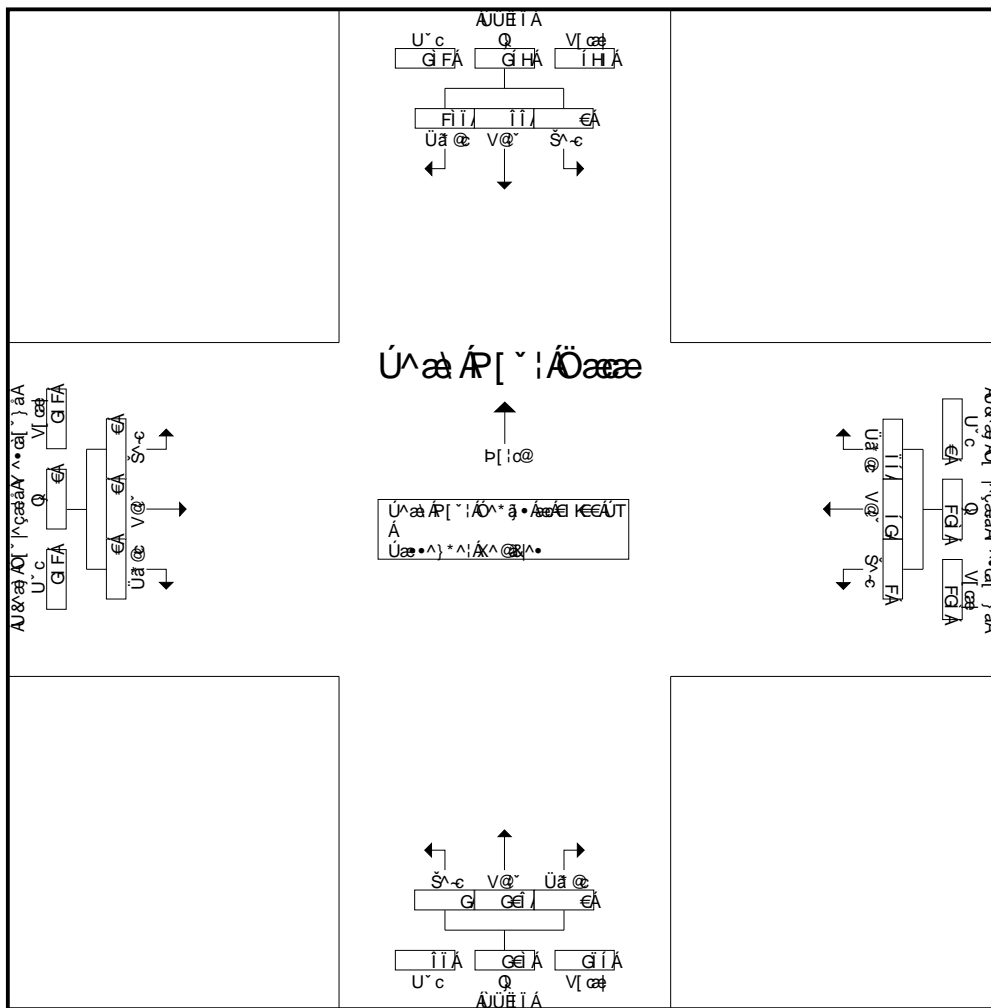

Ú a a Á P [~ | Á O e a a Á I [(Á I K E Á Ú Á Á I K I Á Ú Á Á U a a Á Á - Á
 Ú a a Á P [~ | Á I | Á O e a a O I [! | a a O ^ * á * Á a K

	ei keeÁÚT				ei keeÁÚT				ei keeÁÚT				ei keeÁÚT			
É e Á á • É	€	í	H	I I	€	í	F I	G H	€	I I	€	I I	€	€	€	€
É F I Á á • É	€	F J	I €	I J	1	FF	F I	G	€	I J	€	I J	€	€	€	€
É H e Á á • É	€	F I	í F	I I	€	F I	F I	H e	1	I J	€	í €	€	€	€	€
É I Á á • É	€	26	57	83	€	18	29	47	F	61	€	62	€	€	€	€
V[çá K [] ^	€	I I	F I I	G H	F	I G	I I	F G	G	G é	€	G é	€	€	€	€
Á Á H I E V[çá	€	G é	I H é	Á	e é	I e é	I I é	Á	F	J J	€	Á	€	€	€	Á
U P Ø	€ € € €	é H I	é G e	é I G	é €	é G G	é I I	é I F	é € €	é I I	é € € €	é H U	é € € €	é € € €	é € € €	é € € €

Ó[~]•ÁM|ããáÁ&É
 ÚUÁÓçÁFÍÍ
 Ó[~]•áÁÓÓÁGÍÍ
 ÇI FÍG ÍÉÍÍ

Óã Á-Á[~]•Á^ã&@
 ÞÐUÁÚÈÍ
 ÓÐY ÁÚ&ã ÁÓ[~]•çããÁ Á^ã[~]•á
 Y^ã&@:ÁÚ}}^

ÓÐÁã^ ÁÓÓÍÍ ÚÓY ÚT
 ÚãÁÓ[~]•á ÁÉÉÉÉÉÉÉF
 ÚããÓÓã ÁÁÐÉFEG
 Úã^Á[~]• ÁF

Ó[~]•ÁÚããáÉÓãÁÚ[~]•Á[~]•&•

ÚããÁã^	ÚÙÈÍ Ú[~]•çã[~]•á				U&ã ÁÓ[~]•çããÁ Y^•çã[~]•á Y^•çã[~]•á				ÚÙÈÍ Þ[~]•çã[~]•á				U&ã ÁÓ[~]•çããÁ Y^•çã[~]•á Óãçã[~]•á				QçÁV[~]•çã
	Š^c	V@~	Üã@	Ç[~]•ÈV[~]•çã	Š^c	V@~	Üã@	Ç[~]•ÈV[~]•çã	Š^c	V@~	Üã@	Ç[~]•ÈV[~]•çã	Š^c	V@~	Üã@	Ç[~]•ÈV[~]•çã	
ÉÍ ÁÉÁÚT	€	€	Í	Í	€	Í	F	Í	€	Í	€	Í	€	€	€	€	FJ
ÉÍ ÁÍ ÁÚT	€	F	Í	Í	€	G	€	G	€	Í	€	Í	€	€	€	€	FÍ
ÉÍ ÁÉÁÚT	€	F	G	H	€	€	F	F	€	Í	€	Í	€	€	€	€	Í
ÉÍ ÁÍ ÁÚT	€	€	H	H	€	F	€	F	€	€	€	€	€	€	€	€	Í
V[~]•çã	€	G	FJ	ÇF	€	J	G	FF	€	FÍ	€	FÍ	€	€	€	€	ÍÍ
ÉÍ ÁÉÁÚT	€	€	Í	Í	€	€	G	G	€	F	€	F	€	€	€	€	J
ÉÍ ÁÍ ÁÚT	€	€	G	G	€	€	€	€	€	€	€	€	€	€	€	€	G
ÉÍ ÁÉÁÚT	€	€	I	I	€	F	F	G	€	F	€	F	€	€	€	€	Í
ÉÍ ÁÍ ÁÚT	€	F	F	G	€	€	€	€	€	€	€	€	€	€	€	€	G
V[~]•çã	€	F	FH	FÍ	€	F	H	I	€	G	€	G	€	€	€	€	ÓÉ
Ó[~]•áÁV[~]•çã	€	H	HG	HÍ	€	F€	Í	FÍ	€	FÍ	€	FÍ	€	€	€	€	ÍÍ
Ç[~]•Í&ÇÁ	€	ÍÉ	JFÉ	Á	€	ÍÍÉ	HÉ	Á	€	F€€	€	Á	€	€	€	€	Á
V[~]•çã	€	ÍÉ	ÍÍÉ	ÍÇ	€	FÍÉ	ÍÉ	ÇÉ	€	GÍÉ	€	GÍÉ	€	€	€	€	Á

ÚããÁã^	ÚÙÈÍ Ú[~]•çã[~]•á				U&ã ÁÓ[~]•çããÁ Y^•çã[~]•á Y^•çã[~]•á				ÚÙÈÍ Þ[~]•çã[~]•á				U&ã ÁÓ[~]•çããÁ Y^•çã[~]•á Óãçã[~]•á				QçÁV[~]•çã
	Š^c	V@~	Üã@	Ç[~]•ÈV[~]•çã	Š^c	V@~	Üã@	Ç[~]•ÈV[~]•çã	Š^c	V@~	Üã@	Ç[~]•ÈV[~]•çã	Š^c	V@~	Üã@	Ç[~]•ÈV[~]•çã	
ÚããÁ[~]•Á[~]•çã	€	€	7	Í	€	6	1	7	€	Í	€	Í	€	€	€	€	19
ÉÍ ÁÉÁÚT	€	1	Í	8	€	G	€	G	€	6	€	6	€	€	€	€	FÍ
ÉÍ ÁÍ ÁÚT	€	F	G	H	€	€	F	F	€	Í	€	Í	€	€	€	€	Í
ÉÍ ÁÉÁÚT	€	€	H	H	€	F	€	F	€	€	€	€	€	€	€	€	Í
V[~]•çã	€	G	FJ	ÇF	€	J	G	FF	€	FÍ	€	FÍ	€	€	€	€	ÍÍ
Á Á[~]•çã	€	JÉ	JÉ	Á	€	ÍFÉ	FÍÉ	Á	€	F€€	€	Á	€	€	€	€	Á
UPØ	€€€	É€€	ÉÍJ	ÉÍÍ	€€€	ÉÍÍ	É€€	ÉUH	€€€	ÉG	€€€	ÉG	€€€	€€€	€€€	€€€	ÉFÍ

Ó[~}•ÁM|ãããQ&É
 UUÁQcÁFÍI
 Ó[!:]ããÖÁGÍI
 QI FÁGÍÈÍ

Óã Á-Á[~}•Á^ã&@
 ÞÐJÁUÛÈÍ
 ÖEY KÁU&ã ÁÖ[~}çããÁ^•ã[~}ã
 Y^ã&@:KÁU}}^

ÖEY Áã ^ KÖÓI i UÓY ÚT
 Úã ÁÖ[ã^ KÉÉÉÉÉÉÉF
 ÚããÖÁã KÁHÞEFG
 Úã^Á[KÁG

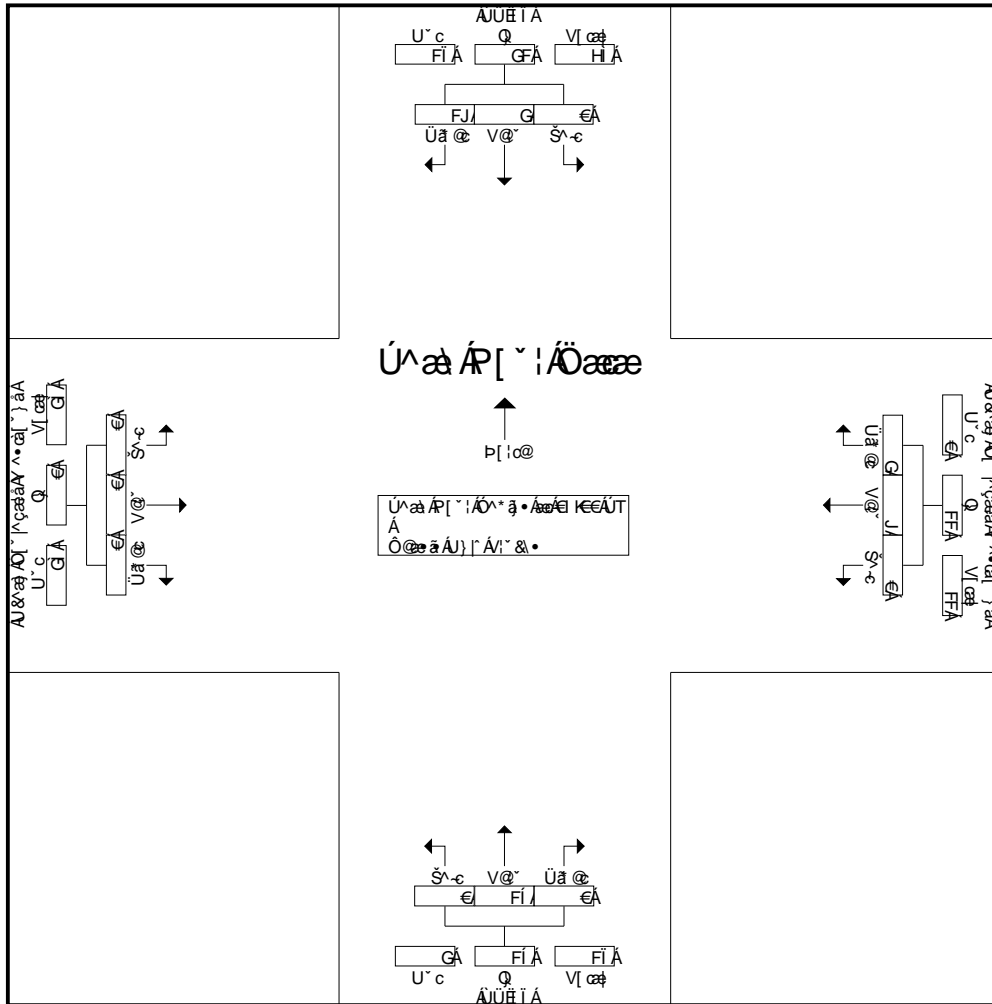

Úã ÁR[~}!Öáæ • Á Á[~} Á KÉÚT Á Á KÍ ÁÚT Á Úã Á Á Á
 Úã ÁR[~}!Öáæ • Á Á[~} Á KÉÚT Á Á KÍ ÁÚT Á Úã Á Á Á

ÉéÁ á•È	€	€	7	ï	€	6	1	7	€	í	€	í	€	€	€	€
ÉFÍ Á á•È	€	1	ï	8	€	G	€	G	€	6	€	6	€	€	€	€
ÉHÉ Á á•È	€	F	G	H	€	€	F	F	€	í	€	í	€	€	€	€
ÉÍ Á á•È	€	€	H	H	€	F	€	F	€	€	€	€	€	€	€	€
V[çãK[~}^	€	G	FJ	GF	€	J	G	FF	€	FÍ	€	FÍ	€	€	€	€
Á Á[~}V[çã	€	JÈ	JèÈ	Á	€	ì FÈ	Fì ÈG	Á	€	Fèè	€	Á	€	€	€	€
UPØ	€€€	È€€	ÈÍJ	ÈÍÍ	€€€	ÈÍÍ	È€€	ÈUH	€€€	ÈG	€€€	ÈG	€€€	€€€	€€€	€€€

Ô[] • ÔÁV jã ãããQ&È
 UU&Ô c&FII
 Ô[] ãããôãGii
 QI FDG i È G I

Ôã Á-Ã[] * Ô^ã&@
 ÞÐJAUÛÈ I
 ÔËY K&U&ã Ô[] | ^çããÁ ^•cã[] á
 Y ^ã&@:K&U } } ^

ÔËY Áã ^ K&SÓI I UÔY ÚT
 Uã ÁÔ[] á K&E&E&E&E&E&F
 ÚããôÖãã K&A&E&E&E&E&F&G
 Úãã^Á[] K&F

Ô[] • ÁU jã cããÈÔ[] ãã ^!ÁV I ^ &•

	ÛÛÈ I Ù[] cãã[] á				U&ã Ô[] ^çãã Y ^•cã[] á Y ^•cã[] á				ÛÛÈ I Þ[] cãã[] á				U&ã Ô[] ^çãã Y ^•cã[] á Ôããã[] á				Q cãã[] cãã	
	Š-c	V@~	Üã @	ç ÈV çãã	Š-c	V@~	Üã @	ç ÈV çãã	Š-c	V@~	Üã @	ç ÈV çãã	Š-c	V@~	Üã @	ç ÈV çãã		
ÛããôÁã ^																		
È K&E&ÛT	€	F	FI	FJ	€	Í	G	Í	€	I I	€	I I	€	€	€	€	€	
È K&FI ÆT	€	H	GF	G	€	Í	G	J	€	I F	€	I F	€	€	€	€	€	
È K&H&ÛT	€	€	GH	GH	€	Í	í	FG	€	œ	€	œ	€	€	€	€	€	
È K&I ÆT	€	H	GG	G	€	Í	í	FF	€	ì	€	ì	€	€	€	€	€	
V[] çãã	€	í	í I	JF	€	GH	FÍ	HJ	€	FFH	€	FFH	€	€	€	€	€	
È K&E&ÛT	€	H	G	H&E	€	G	€	G	€	í	€	í	€	€	€	€	€	
È K&FI ÆT	€	I	G	H&F	€	í	€	í	€	FÍ	€	FÍ	€	€	€	€	€	
È K&H&ÛT	€	G	H&E	H&G	€	í	€	í	€	F	FF	€	FG	€	€	€	€	€
È K&I ÆT	€	H	H&F	H	€	F	€	F	€	FF	€	FF	€	€	€	€	€	
V[] çãã	€	FG	FFÍ	FGÍ	€	FH	€	FH	€	F I I	€	I I	€	€	€	€	€	
Ô!ã áÁV[] çãã	€	FJ	FJJ	GFI	€	HÍ	FÍ	I G	€	F FÍ	€	FÍ	€	€	€	€	€	
çãã] : & @ [] çãã	€	í È	JFÈH	Á	€	í JÈ	HÈÈ	Á	€	ÈÈ J JÈ	€	Á	€	€	€	€	€	
V[] çãã	€	I È	í È	í È	€	í È	HÈÈ	FGÈÈ	€	ÈÈ H ÈÈ	€	H ÈÈ	€	€	€	€	€	

	ÛÛÈ I Ù[] cãã[] á				U&ã Ô[] ^çãã Y ^•cã[] á Y ^•cã[] á				ÛÛÈ I Þ[] cãã[] á				U&ã Ô[] ^çãã Y ^•cã[] á Ôããã[] á				Q cãã[] cãã
	Š-c	V@~	Üã @	ç ÈV çãã	Š-c	V@~	Üã @	ç ÈV çãã	Š-c	V@~	Üã @	ç ÈV çãã	Š-c	V@~	Üã @	ç ÈV çãã	
ÛããôÁã ^																	
Uãã ÁP[] : ÔË çãã • á Ô[] { Á È K&E&ÛT Á È K&I ÆT Á È Uãã Á Á Á Á																	
È K&E&ÛT	€	F	FI	FJ	€	Í	G	Í	€	44	€	44	€	€	€	€	€
È K&FI ÆT	€	3	GF	G	€	7	G	J	€	I F	€	I F	€	€	€	€	€
È K&H&ÛT	€	€	23	GH	€	í	7	12	€	œ	€	œ	€	€	€	€	€
È K&I ÆT	€	H	GG	25	€	í	í	FF	€	ì	€	ì	€	€	€	€	€
V[] çããK[] ^	€	í	í I	JF	€	GH	FÍ	HJ	€	FFH	€	FFH	€	€	€	€	€
Á Á Ô[] ÈV çãã	€	í È	JGH	Á	€	í J	I F	Á	€	F&€€	€	Á	€	€	€	€	€
UPØ	€€€	È È H	È È FH	È È F&€	€€€	È È GF	È È I F	È È FH	€€€	È È I G	€€€	È È I G	€€€	€€€	€€€	€€€	€€€

Ó[~}°ÁM |ã àãÀ&É
 UUÁU cAFI
 Ó[!:] æÖÁG i
 QI FÁi È d i

Óã Á -Á[] * Á^æ&@
 PÉUÁUÛÈ i
 ÓEY ÁU&æ ÁÓ[^ÇääÁ ^•cà[~} á
 Y ^æ@:ÁU' }}'

QÁ^Aæ ^ ÁSÓI i UÓY ÚT
 Úã^ÁU] á^ ÁÉÉÉÉÉÉÉÉÉF
 Uää^ÁÖæ^ ÁÁ^ÁÉÉÉF
 Úæ^Á^ ÁG

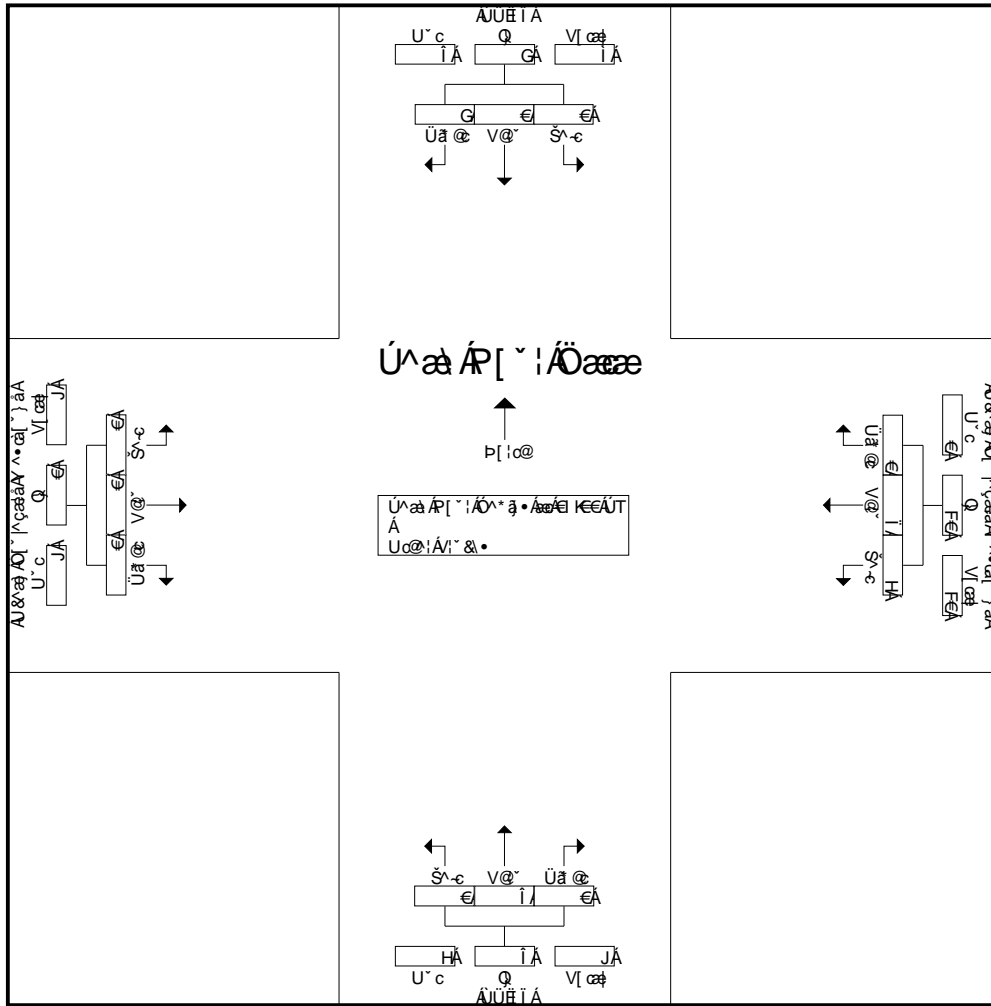

Úã ÁR[~!Öææ Á ÁU{ Ái KÉÚT Ái Ái K I ÁU ÁU^æ ÁÁ -Á
 Úã ÁR[~!Á: Öæ@Ö:]! æ@Ö^ á •ÁæK

	ei KÉÚT				ei KÉÚT				ei KÉÚT				ei KÉÚT			
ÉéÁ á •É	€	€	€	€	1	F	€	G	€	3	€	3	€	€	€	€
ÉFÁ á •É	€	€	1	1	F	G	€	H	€	H	€	H	€	€	€	€
ÉHÁ á •É	€	€	F	F	€	€	€	€	€	€	€	€	€	€	€	€
ÉIÁ á •É	€	€	€	€	F	4	€	5	€	€	€	€	€	€	€	€
V[æ]K[] { ^	€	€	G	G	H	I	€	F€	€	I	€	I	€	€	€	€
Á ÁH] ÉV[æ]	€	€	F€	Á	H€	I€	€	Á	€	F€	€	Á	€	€	€	Á
U P Ø	€€€	€€€	€€€	€€€	€€€	€€€	€€€	€€€	€€€	€€€	€€€	€€€	€€€	€€€	€€€	€€€

Ó{ } , o ÁM |ã, ãããQ&É
 UUÁQ cÁFII
 Ó{ | } ãããÁG II
 QI FÁG I È G I

Óã Á -Á{ } * Á^ã&@
 ÞHÁUÛÈ I
 ÖY KÁU&ã ÁQ{ ^ÇããÁÖãã à{ ^ } à
 Y ^ã&@ :KÁU } } ^

ÖÁ Áã ^ KÖÓI i U ÖÖÖ
 Üã ÁQ{ à^ KÉÉÉÉÉÉÉ
 ÜããÖãã KÁHÞEFG
 Üã ^ ÁQ{ KÖ

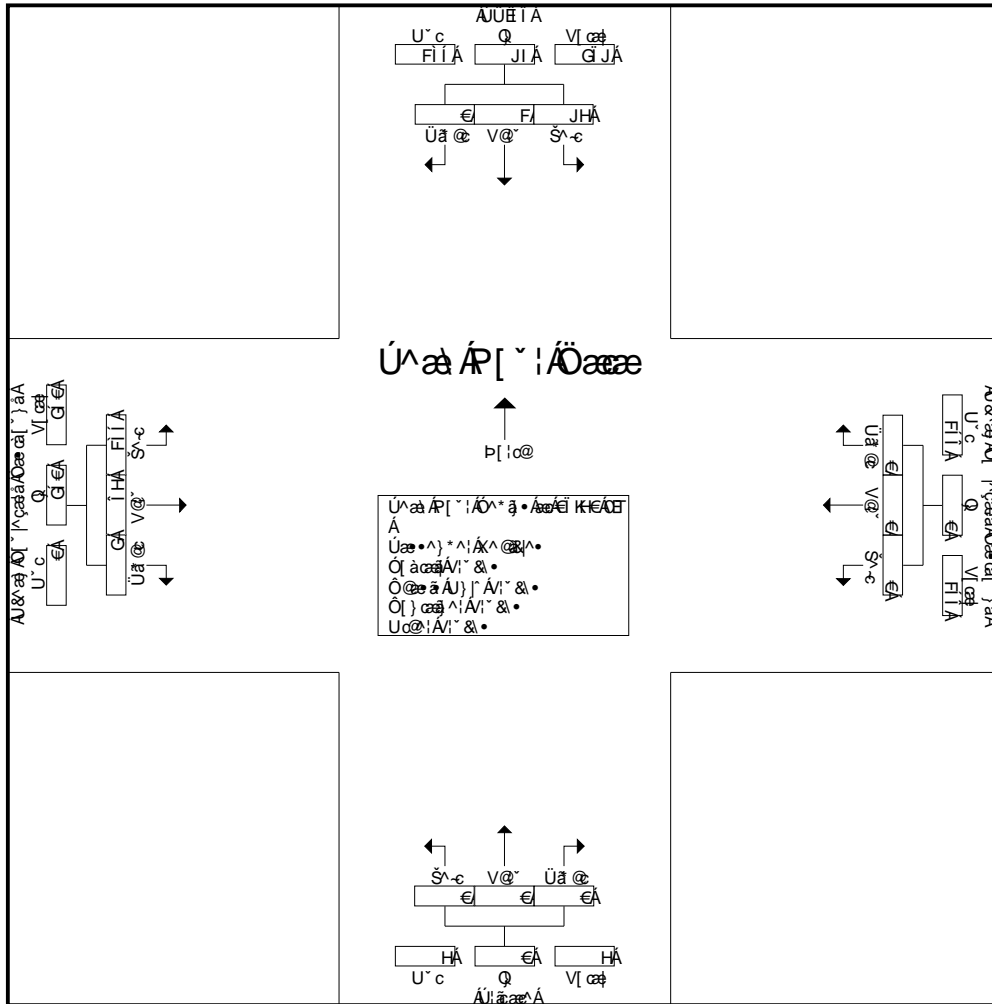

Úãã ÁR{ ^ | ÁQ{ çã ^ á ÁQ{ | ÁV{ KÉÁÖÞ ÁV{ KÍ ÁÖÞ ÁU^ãã ÁÁ ÁF
 Úãã ÁR{ ^ | ÁV{ Öãã ÖÁQ{ | } ãã ÖÁ^ã • ÁãK

	éi KÍ ÁÖÞ				éi KÉÁÖÞ				éi KÉÁÖÞ				éi KÍ ÁÖÞ			
ÉÉÁ á•È	35	4	€	39	€	€	€	€	€	€	€	€	65	Fí	€	81
ÉFÍ Á á•È	G	F	€	GJ	€	€	€	€	€	€	1	1	II	Fí	1	í J
ÉHÁ á•È	GF	€	€	GF	€	€	€	€	€	€	€	€	HG	17	€	I J
ÉÍ Á á•È	FI	€	€	Fí	€	€	€	€	€	€	€	€	II	FI	F	í J
V{ çãK{ ^	FEF	í	€	Féí	€	€	€	€	€	€	F	F	Fí í	í H	G	G €
Á ÁQ{ ÁV{ çã	Jí ÈH	I È	€	Á	€	€	€	€	€	€	F€€	Á	í I	G í G	€ È	Á
UPÖ	ÈÈGF	ÈÈFH	ÈÈ€€	ÈÈíJ	ÈÈ€€	ÈÈ€€	ÈÈ€€	ÈÈ€€	ÈÈ€€	ÈÈ€€	ÈÈ€	ÈÈ€	ÈÈFG	ÈÈG	ÈÈ€€	ÈÈíG

Ó[~ } , ◦ ÁM | á, à, á, Æ & Æ
UUÁÓ | ◦ Á FÍ I
Ó[! !] } á, Æ, Á, G, I
QI F D Á I Æ á

Ó, á, Á, - Á, } * Á, ^ á, @
P, H, K, Á, U, É, Í
O, E, Y, K, Á, U, &, á, } Á, Ó, } ^, á, ç, á, á, Á, O, á, } á
Y ^ á, @, !, K, Á, } ^, }

Ó, Á, P, á, } ^, K, S, Ó, I, Í, U, O, C, E, F
U, á, } Á, Ó, } á, } ^, K, E, C, E, E, E, E, F
U, á, } á, } O, á, } ^, K, H, F, D, E, F, G
U, á, } ^, } Á, } K, G

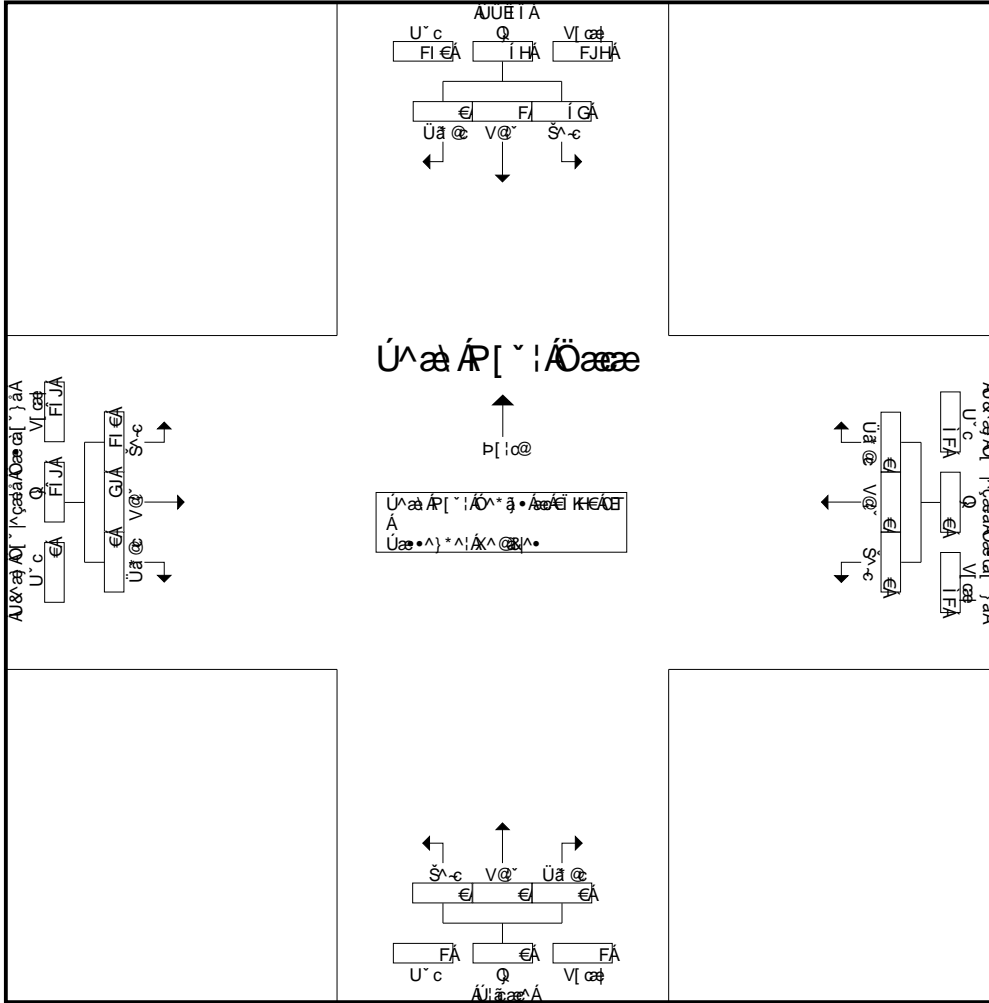

U, } á, } Á, P, } ^, } Á, O, á, } ^, } Á, } K, E, C, E, F, Á, } K, E, I, } C, E, F, } Á, U, } á, } Á, } F
U, } á, } Á, P, } ^, } Á, } O, á, } ^, } Á, } !, } á, } O, } ^, } á, } Á, } K

	é, } K, E, C, E, F				é, } K, E, C, E, F				é, } K, E, C, E, F				é, } K, E, C, E, F				
É, } Á, } á, } É	18	1	€	19	€	€	€	€	€	€	€	€	€	46	13	€	59
É, } F, I, } Á, } á, } É	FÍ	€	€	FÍ	€	€	€	€	€	€	€	€	€	H	í	€	I
É, } H, E, } Á, } á, } É	I	€	€	I	€	€	€	€	€	€	€	€	€	G	í	€	HÍ
É, } I, } Á, } á, } É	FI	€	€	FI	€	€	€	€	€	€	€	€	€	G	H	€	Hf
V ç, } K } ^	Í G	F	€	Í H	€	€	€	€	€	€	€	€	€	FI €	GJ	€	FÍ J
Á, } O, } Á, } F ç	J F	F F	€	Á	€	€	€	€	€	€	€	€	€	í G, F	F F, G	€	Á
UP Ø	È, } G, } G	È, } €	È, } €	È, } J	È, } €	È, } €	È, } €	È, } €	È, } €	È, } €	È, } €	È, } €	È, } €	È, } F	È, } I	È, } €	È, } F

Ó[~]•ÁM|ããÁQ&É
 UUÁOçAFÍI
 Ó[~]ãÁOçÁGÍI
 QIFDÍÉÍ

Óã Á-Á[~]•Á^ã&@
 PDUKÁUÛÉÍ
 ÓEY KÁU&ã ÁO[~]çããÁÁOã cá[~] á
 Y^ã&@:KÁ[~]}}

Óã Áã ^ K&ÓÓI I U ÓOÇE
 Úã ÁO[~] á^ K&E&E&E&E&E
 Úã ÓOã K&F&D&E&F&G
 Úã Á[~] K&F

Ó[~]•ÁU:ããÁÉÍ áãÁVÍ~&•

ÚããÁVã ^	ÚÛÉÍ Ú[~]çã[~] á				U&ã ÁO[~]çããÁ Óã cá[~] á Y^• cá[~] á				Ú:ãã P[~]çã[~] á				U&ã ÁO[~]çããÁ Óã cá[~] á				QçÁV[~] çã
	Š~c	V@~	Úã @	ç ÉV[~] çã	Š~c	V@~	Úã @	ç ÉV[~] çã	Š~c	V@~	Úã @	ç ÉV[~] çã	Š~c	V@~	Úã @	ç ÉV[~] çã	
ÉI K&E&E	F	€	€	F	€	€	€	€	€	€	€	€	F	G	€	H	I
ÉI KÍ ÁO	F	€	€	F	€	€	€	€	€	€	€	€	FF	H	F	FÍ	FÍ
ÉI K&E&E	I	€	€	I	€	€	€	€	€	€	€	€	F€	€	€	F€	FÍ
ÉI KÍ ÁO	F	€	€	F	€	€	€	€	€	€	€	€	H	H	F	í	í
V[~] çã	I	€	€	I	€	€	€	€	€	€	€	€	G	I	G	H	I G
ÉI K&E&E	H	€	€	H	€	€	€	€	€	€	€	€	F	H	€	I	í
ÉI KÍ ÁO	I	€	€	I	€	€	€	€	€	€	€	€	I	H	F	í	FG
ÉI K&E&E	FF	€	€	FF	€	€	€	€	€	€	€	€	FF	F	€	FG	GH
ÉI KÍ ÁO	I	€	€	I	€	€	€	€	€	€	€	€	FÍ	í	€	G	GJ
V[~] çã	GG	€	€	GG	€	€	€	€	€	€	€	€	HH	FÍ	F	I J	í F
Ó!ã áÁV[~] çã	GJ	€	€	GJ	€	€	€	€	€	€	€	€	íí	GH	H	íí	FFH
ç[~]:&@	F€€	€	€	Á	€	€	€	Á	€	€	€	Á	íJ	GÍÉ	HÉ	Á	Á
V[~] çã	GÍÉ	€	€	GÍÉ	€	€	€	€	€	€	€	€	íFÉ	GÉÉ	GÉ	ííÉ	Á

ÚããÁVã ^	ÚÛÉÍ Ú[~]çã[~] á				U&ã ÁO[~]çããÁ Óã cá[~] á Y^• cá[~] á				Ú:ãã P[~]çã[~] á				U&ã ÁO[~]çããÁ Óã cá[~] á				QçÁV[~] çã
	Š~c	V@~	Úã @	ç ÉV[~] çã	Š~c	V@~	Úã @	ç ÉV[~] çã	Š~c	V@~	Úã @	ç ÉV[~] çã	Š~c	V@~	Úã @	ç ÉV[~] çã	
Úã ÁP[~]:Áçãã•ã ÁO[~]çããÁ Úã ÁP[~]:Áçãã•ã ÁO[~]çããÁ																	
ÉI K&E&E	4	€	€	4	€	€	€	€	€	€	€	€	10	€	€	10	14
ÉI KÍ ÁO	F	€	€	F	€	€	€	€	€	€	€	€	H	3	1	í	í
ÉI K&E&E	H	€	€	H	€	€	€	€	€	€	€	€	F	H	€	í	í
ÉI KÍ ÁO	I	€	€	I	€	€	€	€	€	€	€	€	I	H	F	í	FG
V[~] çã	FG	€	€	FG	€	€	€	€	€	€	€	€	FÍ	J	G	GJ	I F
Á ÁO[~] çã	F€€	€	€	Á	€	€	€	Á	€	€	€	Á	íGÉ	HF	íÉ	Á	Á
UPØ	ÉÍÉ	€€€	€€€	ÉÍÉ	€€€	€€€	€€€	€€€	€€€	€€€	€€€	€€€	ÉÍÉ	ÉÍÉ	É€€	ÉÉ	ÉHG

Ó[~ } , o ÁM |ã ,ã a Q&E
 UUÁO] c Á FFI
 Ó[!] }ã ÖÖÁ G I i
 QI FÁ G I E G I

Óã Á -Á[] * Á ^ã&@
 P ÐUÁUÜÉ I
 ÖEY KÁU&ã ÁO[~ ^çããÁÖããà[~] á
 Y ^ã&@:KÁU } } ^

ÖÁ Á çã ^ KÖÓI i U ÖÖE
 Üã ÁO] á ^ KÉÉÉÉÉÉÉÉÉÉ
 Üãã Öãã KÁ B B E F G
 Üã ^ Á [K G

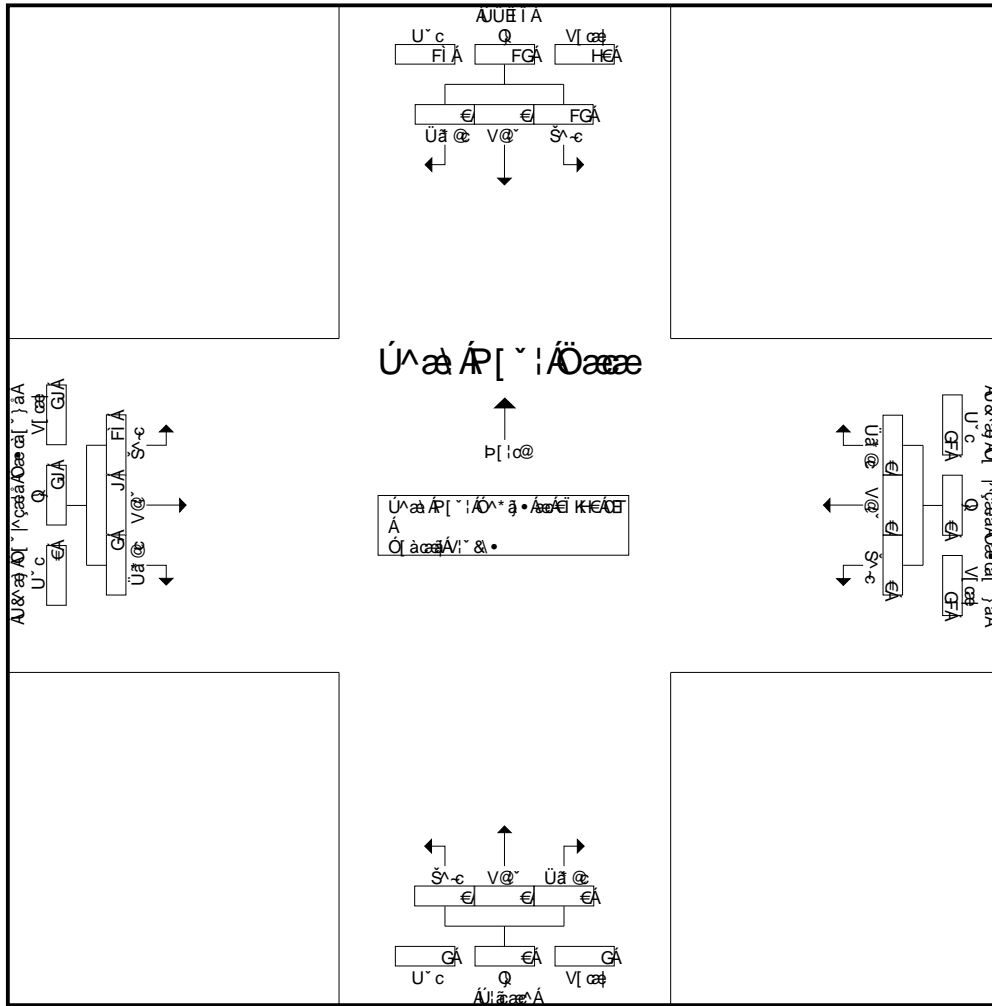

Úãã ÁP[~ ! ÖÖãã * Áãã K K K K K Áãã K K K K K Áãã K K K K K Áãã K K K K K
 Úãã ÁP[~ ! Á [ÖÖãã ÖÖ] ! :ã ÖÖ ^ã * Áãã K

	éi K K K K	€	€	4	éi K K K K	€	€	€	€	éi K K K K	€	€	€	€	éi K K K K	€	€	€	10	
ÉÉÁ á •É	4	€	€	4	€	€	€	€	€	€	€	€	€	€	10	€	€	€	10	
ÉFÍ Á á •É	F	€	€	F	€	€	€	€	€	€	€	€	€	€	H	3	1	€	€	
ÉHÉ Á á •É	H	€	€	H	€	€	€	€	€	€	€	€	€	€	F	H	€	€	€	
ÉÍ Á á •É	I	€	€	I	€	€	€	€	€	€	€	€	€	€	I	H	F	€	€	
V[çã K[] ^	FG	€	€	FG	€	€	€	€	€	€	€	€	€	€	FÍ	J	G	GJ	€	
Á ÁÖ] ÉV[çã	F€€	€	€	Á	€	€	€	€	€	€	€	€	€	€	í GÉ	H F	í È	Á	€	
U P Ö	É Í €	É É É	É É É	É Í €	É É É	É É É	É É É	É É É	É É É	É É É	É É É	É É É	É É É	É É É	É Í €	É Í €	É É €	É G	€	€

Ö[] ÖÁM |ä äáÁQ&É
 UUÁÖ cÁFI
 Ö[] äÖÖÁGII
 QI FDG i È G I

Öä Á -Á[] * ÁÖä@
 ÞÖUÁÜÈ I
 ÖY ÁÜ&ä ÁÖ[] ^çäáÁÖä ä[] ä
 Y ^ä@:ÁÜ } }

ÖÁ Áä ^ KÖÖI UÖÖE
 Üä ÁÖ[] ä KEEEEEEF
 Üä ÖÖä KÁBDEFG
 Üä ÁÖ[] KÁ

Ö[] • ÁÜä äáÖÖä ÁÜ } Á/ & •

ÜçäÖÁÜ ^	ÜÜÈ I Ü[] cÖ[] ä				U&ä ÁÖ[] ^çäá Öä ä[] ä Y ^• ä[] ä				Ü[] ää P[] cÖ[] ä				U&ä ÁÖ[] ^çäá Öä ä[] ä Öä ä[] ä				Q äV[] çä
	Š-c	V@	Üä @	ç ÈV[] çä	Š-c	V@	Üä @	ç ÈV[] çä	Š-c	V@	Üä @	ç ÈV[] çä	Š-c	V@	Üä @	ç ÈV[] çä	
èi KEEÖE	€	€	€	€	€	€	€	€	€	€	€	€	€	€	€	€	€
èi KÍ ÁÖE	€	€	€	€	€	€	€	€	€	€	€	€	€	€	€	€	€
èi KEEÖE	€	€	€	€	€	€	€	€	€	€	€	€	H	€	€	€	H
èi KÍ ÁÖE	€	€	€	€	€	€	€	€	€	€	€	€	€	€	€	€	€
V[] çä	€	€	€	€	€	€	€	€	€	€	€	€	H	€	€	H	H
èi KEEÖE	€	€	€	€	€	€	€	€	€	€	€	€	€	€	€	€	€
èi KÍ ÁÖE	F	€	€	F	€	€	€	€	€	€	€	€	F	€	€	F	G
èi KEEÖE	€	€	€	€	€	€	€	€	€	€	€	€	H	€	€	H	H
èi KÍ ÁÖE	I	€	€	I	€	€	€	€	€	€	€	€	I	€	€	I	I
V[] çä	I	€	€	I	€	€	€	€	€	€	€	€	I	€	€	I	FH
Ö[] ä áÁ[] çä	I	€	€	I	€	€	€	€	€	€	€	€	FF	€	€	FF	FÍ
ç[] :&ÖÁ	FEE	€	€	Á	€	€	€	Á	€	€	€	Á	FEE	€	€	Á	Á
V[] çä	HFEG	€	€	HFEG	€	€	€	€	€	€	€	€	iiÈ	€	€	iiÈ	

ÜçäÖÁÜ ^	ÜÜÈ I Ü[] cÖ[] ä				U&ä ÁÖ[] ^çäá Öä ä[] ä Y ^• ä[] ä				Ü[] ää P[] cÖ[] ä				U&ä ÁÖ[] ^çäá Öä ä[] ä Öä ä[] ä				Q äV[] çä
	Š-c	V@	Üä @	ç ÈV[] çä	Š-c	V@	Üä @	ç ÈV[] çä	Š-c	V@	Üä @	ç ÈV[] çä	Š-c	V@	Üä @	ç ÈV[] çä	
Üä ÁÖ[] :ÁÖ ä[] • ä ÁÖ[] { Ái KEEÖE Ái Ái KÍ ÁÖE ÁÜä ÁÜä ÁÜä																	
Üä ÁÖ[] :Ái ÁÖ[] ä ÁÖ[] • ^&ä[] ÁÖ[] ä • ÁÖ[] KEEÖE													3	€	€	3	3
èi KEEÖE	€	€	€	€	€	€	€	€	€	€	€	€	€	€	€	€	€
èi KÍ ÁÖE	€	€	€	€	€	€	€	€	€	€	€	€	€	€	€	€	€
èi KEEÖE	€	€	€	€	€	€	€	€	€	€	€	€	€	€	€	€	€
èi KÍ ÁÖE	1	€	€	1	€	€	€	€	€	€	€	€	F	€	€	F	G
V[] çä Á[] { ^	F	€	€	F	€	€	€	€	€	€	€	€	I	€	€	I	I
Á ÁÖ[] ÈV[] çä	FEE	€	€	Á	€	€	€	Á	€	€	€	Á	FEE	€	€	Á	Á
UPØ	EG	€	EECE	EECE	EG	€	EECE	EECE	EECE	EECE	EECE	EECE	ÈHH	EECE	EECE	ÈHH	ÈFI

Ô[˘] ◦ ʌM | ɑ̃ ɑ̃ ɑ̃ ɑ̃ ɑ̃ ɑ̃
 UU ʌ ʌ ʌ ʌ ʌ ʌ ʌ ʌ
 Ô[˘] | ʌ ʌ ʌ ʌ ʌ ʌ ʌ ʌ
 Q | F ʌ i ɛ ɛ i

Ô ʌ ʌ ʌ ʌ ʌ ʌ ʌ ʌ
 F ʌ ʌ ʌ ʌ ʌ ʌ ʌ ʌ
 Ô ʌ ʌ ʌ ʌ ʌ ʌ ʌ ʌ
 Y ʌ ʌ ʌ ʌ ʌ ʌ ʌ ʌ

Ô ʌ ʌ ʌ ʌ ʌ ʌ ʌ ʌ
 U ʌ ʌ ʌ ʌ ʌ ʌ ʌ ʌ
 U ʌ ʌ ʌ ʌ ʌ ʌ ʌ ʌ
 U ʌ ʌ ʌ ʌ ʌ ʌ ʌ ʌ

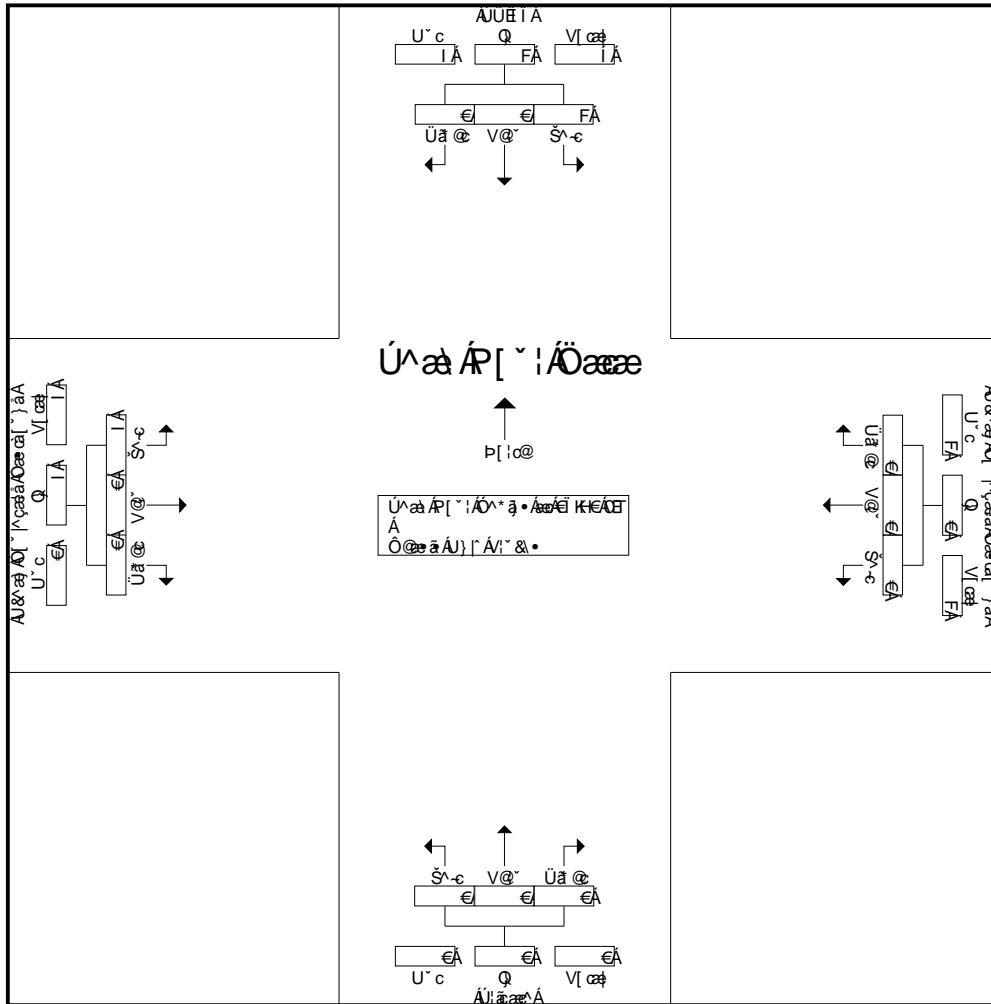

Uã ʌ ʌ ʌ ʌ ʌ ʌ ʌ ʌ
 Uã ʌ ʌ ʌ ʌ ʌ ʌ ʌ ʌ

	Uã ʌ ʌ ʌ ʌ ʌ ʌ ʌ ʌ				Uã ʌ ʌ ʌ ʌ ʌ ʌ ʌ ʌ			
	Uã	ʌ	ʌ	ʌ	ʌ	ʌ	ʌ	ʌ
É ʌ ʌ ʌ ʌ ʌ ʌ ʌ ʌ	€	€	€	€	€	€	€	€
É ʌ ʌ ʌ ʌ ʌ ʌ ʌ ʌ	€	€	€	€	€	€	€	€
É ʌ ʌ ʌ ʌ ʌ ʌ ʌ ʌ	€	€	€	€	€	€	€	€
É ʌ ʌ ʌ ʌ ʌ ʌ ʌ ʌ	1	€	€	1	€	€	€	€
V ʌ ʌ ʌ ʌ ʌ ʌ ʌ ʌ	F	€	€	F	€	€	€	€
ʌ ʌ ʌ ʌ ʌ ʌ ʌ ʌ	F	€	€	ʌ	€	€	€	ʌ
U ʌ ʌ	€	€	€	€	€	€	€	€

Ô[~]cÁM|ä äáÁQ&É
 ÚUÁÖ çÁFíí
 Ô[~] äÉÖÇÁGíí
 ÇíFDGíÈGí

Ôä Á-Á[~] *Á^ää@
 ÞÉUÁÚÉÈí
 ÔÉY KÁU&äÁ Ô[~] |ççääÁÔäçà[~] ä
 Y^ää@:KÁU} } }

ÔÄ Áç ^ KÖÖÍí ÚÔÇÉF
 Úä ÁÖ[~] á^ KÉÉÉÉÉÉF
 ÚççcÖçç KÁÉÉÉÉF
 Úäç^Áç KÁ

Ô[~]cÁM|ä äáÁQ&É } çç Á:ÁV[~] &•

ÚççcÁVá ^	ÚÚÈí Ú[~]çç[~] á				U&ä ÁÖ[~] ççääÁÔäçà[~] á Y^•ç[~] á				Úiççç Þ[~]çç[~] á				U&ä ÁÖ[~] ççääÁÔäçà[~] á Ôäçà[~] á				QçV[~] çç
	Š^c	V@	Úäç	ç ÉV[~] çç	Š^c	V@	Úäç	ç ÉV[~] çç	Š^c	V@	Úäç	ç ÉV[~] çç	Š^c	V@	Úäç	ç ÉV[~] çç	
Éí KÉÇÉF	H	€	€	H	€	€	€	€	€	€	€	€	F	F	€	G	I
Éí KÍ ÁÖF	F	€	€	F	€	€	€	€	€	€	€	€	H	F	€	I	I
Éí KÉÇÉF	H	€	€	H	€	€	€	€	€	€	€	€	H	G	€	I	I
Éí KÍ ÁÖF	F	€	€	F	€	€	€	€	€	€	€	€	F	F	€	G	H
V[~] çç	I	€	€	I	€	€	€	€	€	€	€	€	I	I	€	FH	GF
Éí KÉÇÉF	I	€	€	I	€	€	€	€	€	€	€	€	H	I	€	J	Fí
Éí KÍ ÁÖF	I	€	€	I	€	€	€	€	€	€	€	€	I	G	€	F€	Fí
Éí KÉÇÉF	F	€	€	F	€	€	€	€	€	€	€	€	I	I	€	Fí	Fí
Éí KÍ ÁÖF	F	€	€	F	€	€	€	€	€	€	€	€	I	I	€	Fí	Fí
V[~] çç	Fí	€	€	Fí	€	€	€	€	€	€	€	€	G	GH	€	Ii	Ií
Ô[~] ä áÁV[~] çç	Gí	€	€	Gí	€	€	€	€	€	€	€	€	HH	G	€	íF	íí
çç : & @	F€€	€	€	Á	€	€	€	Á	€	€	€	€	ííÈ	ííÈ	€	Á	Á
V[~] çç	GJÈ	€	€	GJÈ	€	€	€	€	€	€	€	€	HÈ	HGÈ	€	íÈ	Á

ÚççcÁVá ^	ÚÚÈí Ú[~]çç[~] á				U&ä ÁÖ[~] ççääÁÔäçà[~] á Y^•ç[~] á				Úiççç Þ[~]çç[~] á				U&ä ÁÖ[~] ççääÁÔäçà[~] á Ôäçà[~] á				QçV[~] çç
	Š^c	V@	Úäç	ç ÉV[~] çç	Š^c	V@	Úäç	ç ÉV[~] çç	Š^c	V@	Úäç	ç ÉV[~] çç	Š^c	V@	Úäç	ç ÉV[~] çç	
Úäç ÁV[~] ÁÖ[~] çç • ä ÁÖ[~] { Áí KÉÇÉF Áí Áí KÍ ÁÖF ÁÚU çç ÁV[~] -F																	
Úäç ÁV[~] Áí ÁÖ[~] çç ÁV[~] • ÁÖ[~] çç • ÁÖ[~] çç KÉÇÉF																	
Éí KÉÇÉF	H	€	€	H	€	€	€	€	€	€	€	€	H	G	€	I	I
Éí KÍ ÁÖF	F	€	€	F	€	€	€	€	€	€	€	€	F	F	€	G	H
Éí KÉÇÉF	8	€	€	8	€	€	€	€	€	€	€	€	H	6	€	J	17
Éí KÍ ÁÖF	I	€	€	I	€	€	€	€	€	€	€	€	8	G	€	10	Fí
V[~] çç ÁV[~] ^	FJ	€	€	FJ	€	€	€	€	€	€	€	€	Fí	FF	€	G	Ií
Á ÁÖ[~] ÁV[~] çç	F€€	€	€	Á	€	€	€	Á	€	€	€	€	ííÈ	IçH	€	Á	Á
UPØ	È JI	ÈÈÈÈ	ÈÈÈÈ	È JI	ÈÈÈÈ	ÈÈÈÈ	ÈÈÈÈ	ÈÈÈÈ	ÈÈÈÈ	ÈÈÈÈ	ÈÈÈÈ	ÈÈÈÈ	È Í J	È í I	ÈÈÈÈ	È í €	È í G

Ó[~] ◦ ÁM | á á á Q & E
 UUÁQ] c Á F I I
 Ó[!] } á á á Q & I I
 Q I F D á I È á I

Óá Á - Á[] * Á^ á á @
 P B U K Á U È I
 ÓEY K Á U & á Á Q [~ | ^ ç á á Á Ó á á [~] á
 Y ^ á á @ : K Á U } } ^

Q Á P á ^ K S Ó I i U Ó Ò E F
 Ú á Á Q] á ^ K E E E E E E F
 Ú á á Ó á á K H F D E F G
 Ú á á Á P [K G

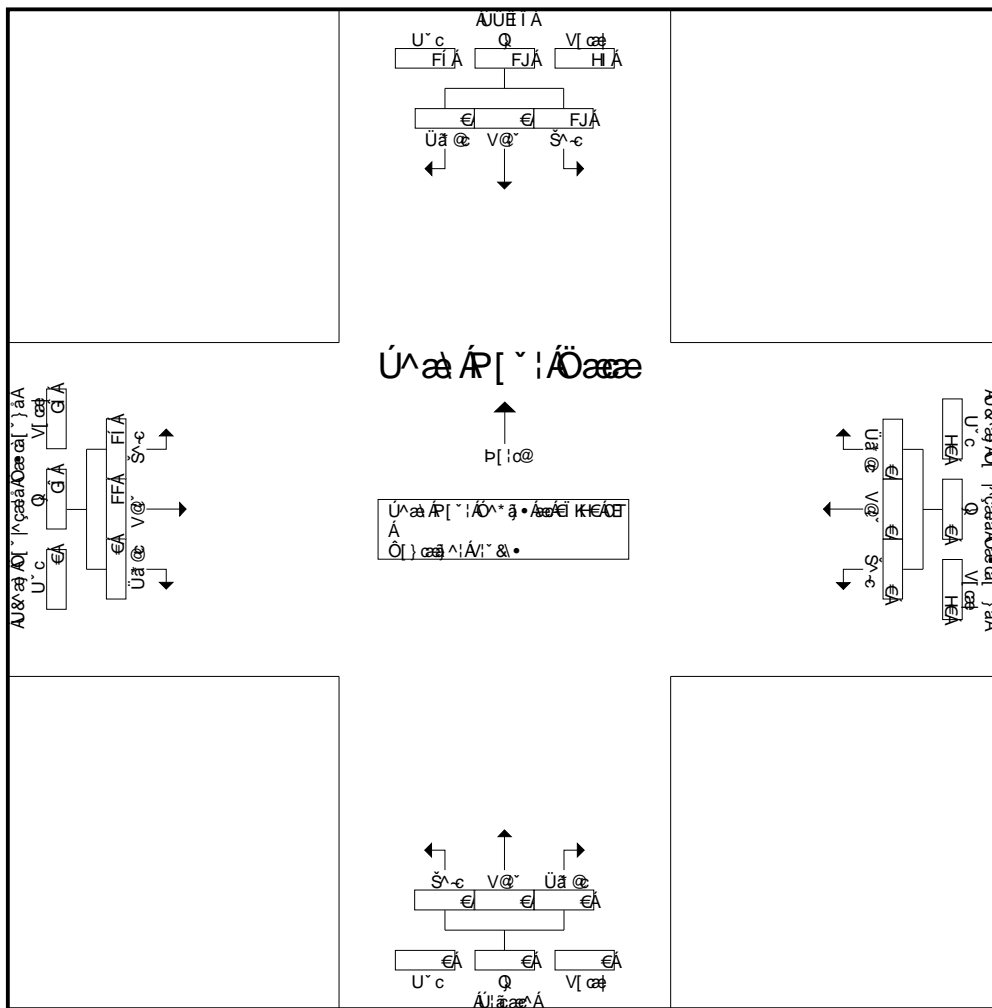

Ú á á Á P [~ | Á Q á á * á Á Q [! Á I K H Á F Á Á K I Á F Á Á U^c á á Á - Á
 Ú á á Á P [~ | Á Q á á Q [!] } á á Q Á * á Á K

	é I K H Á F				é I K H Á F				é I K H Á F				é I K H Á F			
É é Á á · È	H	€	€	H	€	€	€	€	€	€	€	€	H	G	€	í
É F I Á á · È	F	€	€	F	€	€	€	€	€	€	€	€	F	F	€	G
É H E Á á · È	8	€	€	8	€	€	€	€	€	€	€	€	H	6	€	J
É I Á á · È	i	€	€	i	€	€	€	€	€	€	€	€	8	G	€	10
V I ç á K [] ^	FJ	€	€	FJ	€	€	€	€	€	€	€	€	F I	FF	€	Q
Á Á Q] Á V I ç á	F e e	€	€	Á	€	€	€	€	€	€	€	€	í i È	I G H	€	Á
U P Ø	È J I	È È È	È È È	È J I	È È È	È È È	È È È	È È È	È È È	È È È	È È È	È È È	È J I	È I I	È È È	È I €

Ö[~], ÁM|ä ä^áQ&É
 UUÁÖ cÁFI
 Ö[~] äÖÖGii
 QIFDGiÉGi

Öä Á-Á[~] *Á^æ@
 ÞUJÁUËI
 ÖY KÁ&ä Á[~] ^çsäÁÖä cá[~] ä
 Y^æ@:KÁ[~] }

Ö^Áæ ^ KÖÖI UÖÖE
 Üä Á[~] ä^ KÉÉÉÉÉÉÉÉÉ
 Üä ÖÖä KÁÉÉÉÉÉÉÉÉ
 Üä ^Á[~] KÁ

Ö[~] • ÁUä cáÉUc@ÁI^ & •

ÜçäÖVä ^	ÜÜË I Ú[~] c@[~] } ä				U&ä Á[~] ^çsä Öä cá[~] } ä Y^• cá[~] } ä				Ú[~] äæ P[~] c@[~] } ä				U&ä Á[~] ^çsä Öä cá[~] } ä Öä cá[~] } ä				QäV[~] çæ
	Š^c	V@~	Üä @	ç ÉV[~] çæ	Š^c	V@~	Üä @	ç ÉV[~] çæ	Š^c	V@~	Üä @	ç ÉV[~] çæ	Š^c	V@~	Üä @	ç ÉV[~] çæ	
Éi KÉÖE	€	€	€	€	€	€	€	€	€	€	€	€	€	€	€	€	€
Éi KÍ ÁÖE	€	€	€	€	€	€	€	€	€	€	€	€	€	€	€	€	€
Éi KÉÖE	H	€	€	H	€	€	€	€	€	€	€	€	H	F	€	I	I
Éi KÍ ÁÖE	H	€	€	H	€	€	€	€	€	€	€	€	G	I	€	I	FF
V[~] çæ	I	€	€	I	€	€	€	€	€	€	€	€	I	I	€	FG	FI
Éi KÉÖE	G	€	€	G	€	€	€	€	€	€	€	€	€	F	€	F	H
Éi KÍ ÁÖE	F	€	€	F	€	€	€	€	€	€	€	€	H	I	€	J	F€
Éi KÉÖE	G	€	€	G	€	€	€	€	€	€	€	€	€	I	€	I	I
Éi KÍ ÁÖE	H	€	€	H	€	€	€	€	€	€	€	€	H	I	€	F€	FH
V[~] çæ	I	€	€	I	€	€	€	€	€	€	€	€	I	FJ	€	G	HH
Ö!ä äÁV[~] çæ	FI	€	€	FI	€	€	€	€	€	€	€	€	FF	G	€	H	I F
ç[~] :&ÖÁ	F€€	€	€	Á	€	€	€	Á	€	€	€	Á	GJÉ	IÉH	€	Á	Á
V[~] çæ	GÉ	€	€	GÉ	€	€	€	€	€	€	€	€	GFÉ	I F	€	IÉ	

ÜçäÖVä ^	ÜÜË I Ú[~] c@[~] } ä				U&ä Á[~] ^çsä Öä cá[~] } ä Y^• cá[~] } ä				Ú[~] äæ P[~] c@[~] } ä				U&ä Á[~] ^çsä Öä cá[~] } ä Öä cá[~] } ä				QäV[~] çæ
	Š^c	V@~	Üä @	ç ÉV[~] çæ	Š^c	V@~	Üä @	ç ÉV[~] çæ	Š^c	V@~	Üä @	ç ÉV[~] çæ	Š^c	V@~	Üä @	ç ÉV[~] çæ	
Üä Á[~] :Á[~] ä^• Á[~] { Ái KÉÖE Ái Ái KÍ ÁÖE ÁU^ä ÁÁ-Á																	
Üä Á[~] :Á[~] Á[~] cáÁÖ^•^&ä } Á^• ä^• Ái KÉÖE																	
Éi KÉÖE	3	€	€	3	€	€	€	€	€	€	€	€	3	F	€	I	I
Éi KÍ ÁÖE	H	€	€	H	€	€	€	€	€	€	€	€	G	6	€	I	11
Éi KÉÖE	G	€	€	G	€	€	€	€	€	€	€	€	€	F	€	F	H
Éi KÍ ÁÖE	F	€	€	F	€	€	€	€	€	€	€	€	H	I	€	9	F€
V[~] çæK[~] { ^	J	€	€	J	€	€	€	€	€	€	€	€	I	FI	€	GG	HF
Á Á[~] ÉV[~] çæ	F€€	€	€	Á	€	€	€	Á	€	€	€	Á	HÉ	IÉ	€	Á	Á
UPØ	ÉI€	ÉÉÉ	ÉÉÉ	ÉI€	ÉÉÉ	ÉÉÉ	ÉÉÉ	ÉÉÉ	ÉÉÉ	ÉÉÉ	ÉÉÉ	ÉÉÉ	ÉI€	ÉI H	ÉÉÉ	ÉÉÉ	ÉÉ

Ó[~ } • ÁM | á á á Á Q & E
 UU Á O | c Á F I I
 Ó[! |] á á Á O Á G I i
 Q I F Á G I É G I

Ó á Á - Á [] * Á ^ á á @
 P B U K Á U É I
 O E Y K Á U & á Á [~ | ^ ç á á Á O á á [~] á
 Y ^ á á @ ! K Á U } } ^

Q Á P á ^ K S O O I i U O O C E F
 Ú á Á O | á ^ K E C C C C C C F
 Ú á á O á á K H B D E F G
 Ú á ^ Á P | K G

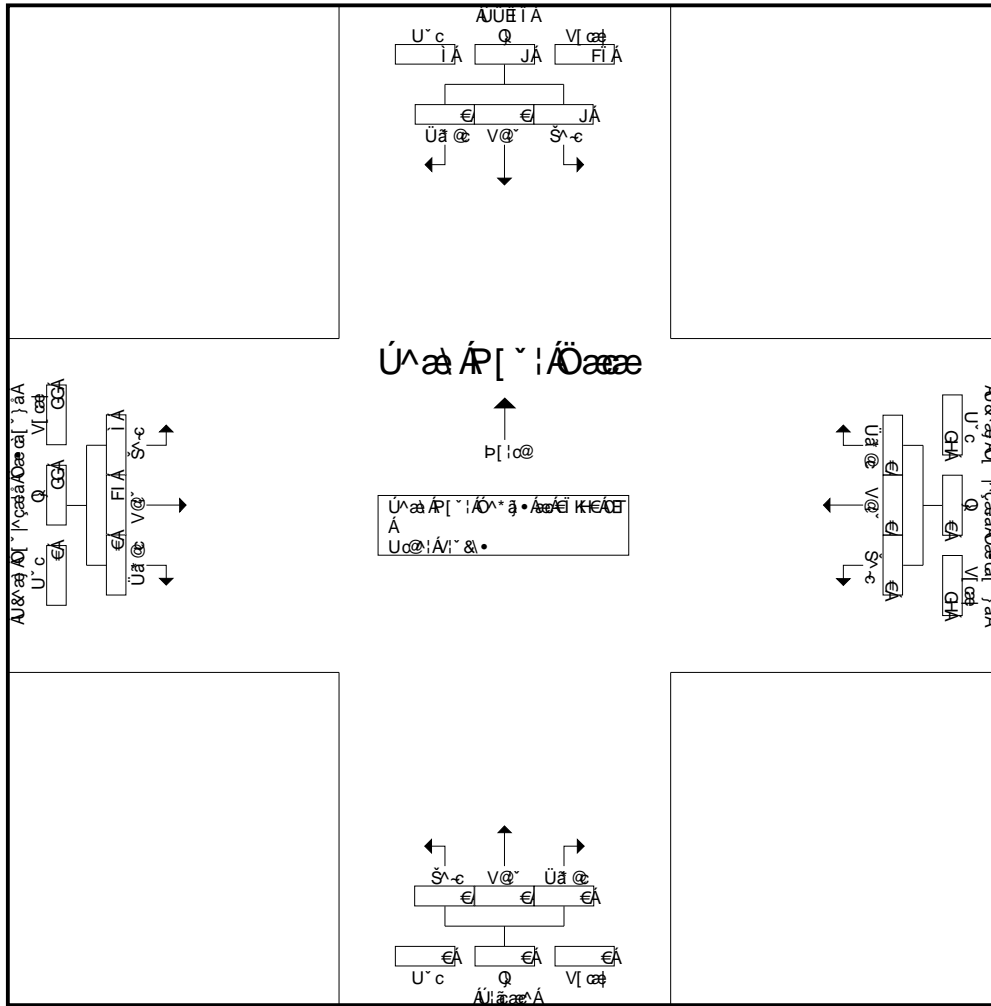

Ú á á Á P [~ | Á O á á • á Á [(Á i K H Á O E F Á Á K I Á O E F Á Á Ú á á Á F Á F
 Ú á á Á P [~ | Á i Á O á á O Á] ! á á O Á • á Á K

	é i K H Á O E F				é i K H Á O E F				é i K H Á O E F				é i K H Á O E F				
É e Á á • É	3	€	€	3	€	€	€	€	€	€	€	€	€	3	F	€	i
É f i Á á • É	H	€	€	H	€	€	€	€	€	€	€	€	€	G	6	€	i
É h e Á á • É	G	€	€	G	€	€	€	€	€	€	€	€	€	€	F	€	F
É i i Á á • É	F	€	€	F	€	€	€	€	€	€	€	€	€	H	i	€	9
V I ç á Á [] ^	J	€	€	J	€	€	€	€	€	€	€	€	€	i	F I	€	G G
Á Á O Á] Á V I ç á Á	F € €	€	€	Á	€	€	€	€	€	€	€	€	€	H i H	i H	€	Á
U P O	É i €	É € €	É € €	É i €	É € €	É € €	É € €	É € €	É € €	É € €	É € €	É € €	É € €	É i i	É i H	É € €	É F F

Ö|~)•ÁV|ã ä•áÁ&É
 UUÁÖ|çÁFÍÍ
 Ö|{)äÖÖáGíí
 QÍFDGíÈGí

Öä Á-Á|}•Á•á&@
 ÞDUÁUÛÈÍ
 ÖËVÁU&á|ÁÖ|~|çáäáÁÖä|~}á
 Y^•á@:KÁ|}•}

Öä Á•á ^ KÖÖÍ UÖÖT Ö
 Üä ÁÖ| ä^ KÉÉÉÉÉÉÉÉ
 ÜäöÖä• KÞDEFG
 Üä Á•| KÉ

Ö|{~)•ÁV|ã ä•áÁ&É••^•Á•Ä•Ö| çáÁV|• &•ÁÖ| çá ÁU|~ ÁV|• &•ÁÖ| çá ^ ÁV|• &•ÁÜ|ç ÁV|• &•

ÜçäöÁV ^	ÜÜÈÍ Ü ~çá ~}á				U&á ÁÖ ~ çáä Öä ~}á Y^•çá ~}á				Ü ãçæ P çá ~}á				U&á ÁÖ ~ çáä Öä ~}á				QçÁV çá
	Š-ç	V@~	Üä @	ç ÈV çá	Š-ç	V@~	Üä @	ç ÈV çá	Š-ç	V@~	Üä @	ç ÈV çá	Š-ç	V@~	Üä @	ç ÈV çá	
ÉFKÉÁÜT	GJ	G	€	HF	€	€	€	€	€	€	F	F	ÍÍ	G	€	IJ	FG
ÉFKÍ ÁÜT	FJ	I	€	GH	€	€	€	€	€	€	G	H	ÍH	HÍ	€	JJ	FĞ
ÉFKÉÁÜT	G	Í	€	HF	€	€	€	€	€	€	F	G	ÍÍ	HÉ	F	FFI	FÍF
ÉFKÍ ÁÜT	GH	€	€	GH	€	€	€	€	€	€	I	F	I	FFI	HÍ	G	FÍF
V çá	JÍ	FF	€	FÈ	€	€	€	€	€	€	FÈ	Í	FÍ	HĞ	FG	H	IÍÍ
ÉGKÉÁÜT	G	Í	€	HF	€	€	€	€	€	€	Í	I	FF	FĞ	G	F	FÍÍ
ÉGKÍ ÁÜT	G	H	€	G	€	€	€	€	€	€	FÈ	G	FG	FFÍ	I€	€	FÍÍ
ÉGKÉÁÜT	J	F	€	FÈ	€	€	€	€	€	€	€	€	€	FĞ	HG	€	FÍJ
ÉGKÍ ÁÜT	Í	€	€	Í	€	€	€	€	€	€	€	€	€	FĞ	FJ	G	FÍÍ
V çá	ÍÍ	J	€	ÍÍ	€	€	€	€	€	€	FÍ	Í	GH	IJF	FFI	GJ	ÍH
Ö ä áÁV çá	FÍ G	ÖE	€	FÍ G	€	€	€	€	€	€	G	FH	I€	I FJ	G H	HG	FÈJÍ
Ö {~)•ÁV çá	Í J	FF	€	Á	€	€	€	€	€	€	ÍÍ È	HÈ	Á	ÍÍ È	GÈ	GÈ	Á
V çá	FÈH	FÈ	€	FÈÈ	€	€	€	€	€	€	GÈ	F	H	Í GÈ	FÍ È	GÈ	Í HÈ
Üä•Á•^ ÁV çá	ÍÍ	FÍ	€	Í€	€	€	€	€	€	€	FÍ	FF	G	FJJ	ÍH	H	GÍ
Á ÁV çá	HÈH	Í€	€	H ÈÈ	€	€	€	€	€	€	ÍH	ÍÍ È	Í€	G ÈÈ	G ÈÈ	JÈÈ	G ÈÈ
Ö çá ÁV • &•	GJ	G	€	HF	€	€	€	€	€	€	Í	G	I	GGJ	IJ	€	HÍ
Á ÁV çá ÁV • &•	FÍ È	FÈ	€	FÍ	€	€	€	€	€	€	GÈÈ	FÍ È	ÖE	G	HÍ È	€	GÍÈ
Öä áÁV ~ ÁV • &•	FÍ	€	€	FÍ	€	€	€	€	€	€	F	€	F	FJF	H	FÍ	G H
Á ÁV çá ÁV ~ ÁV • &•	JÈÈ	€	€	Í ÈÈ	€	€	€	€	€	€	HÈÈ	€	GÈÈ	GÈÈ	FÍ ÈÈ	I HÈÈ	GÈÈ
Ö çá ÁV ~ ÁV • &•	FÍ	€	€	FÍ	€	€	€	€	€	€	F	€	F	FJF	H	FÍ	G H
Á ÁV çá ÁV ~ ÁV • &•	JÈÈ	€	€	Í ÈÈ	€	€	€	€	€	€	HÈÈ	€	GÈÈ	GÈÈ	FÍ ÈÈ	I HÈÈ	GÈÈ
Uçä ÁV • &•	ÍÍ	G	€	IJ	€	€	€	€	€	€	G	€	G	J	FÍ	F	G
Á ÁV çá ÁV ~ ÁV • &•	GJ	FÈ	€	G ÈÈ	€	€	€	€	€	€	Í ÈÈ	€	I	FÈÈ	Í ÈÈ	HÈÈ	GÈÈ

ÜçäöÁV ^	ÜÜÈÍ Ü ~çá ~}á				U&á ÁÖ ~ çáä Öä ~}á Y^•çá ~}á				Ü ãçæ P çá ~}á				U&á ÁÖ ~ çáä Öä ~}á				QçÁV çá
	Š-ç	V@~	Üä @	ç ÈV çá	Š-ç	V@~	Üä @	ç ÈV çá	Š-ç	V@~	Üä @	ç ÈV çá	Š-ç	V@~	Üä @	ç ÈV çá	
Üä ÁV ~ ÁV çá • ÁV { ÁV ÉFKÉÁÜT ÁV ÉGKÍ ÁÜT ÁV Üä ÁV ÁV ÁV																	
Üä ÁV ~ ÁV çá • ÁV { ÁV ÉFKÍ ÁÜT																	
ÉFKÍ ÁÜT	GH	€	€	GH	€	€	€	€	€	€	I	F	I	FFI	HÍ	2	FÍF
ÉGKÉÁÜT	26	5	€	31	€	€	€	€	€	€	Í	4	FF	127	G	F	FÍÍ
ÉGKÍ ÁÜT	G	H	€	G	€	€	€	€	€	€	10	G	12	FFÍ	40	€	FÍÍ
ÉGKÉÁÜT	J	F	€	FÈ	€	€	€	€	€	€	€	€	€	FĞ	HG	€	159
V çá ÁV ~ ÁV çá	Í G	J	€	JF	€	€	€	€	€	€	G	Í	HF	ÍÍÍ	FH	H	ÍG
Á ÁV çá ÁV ~ ÁV çá	JÈÈ	JÈÈ	€	Á	€	€	€	€	€	€	ÍÍ ÈÈ	GÈÈ	Á	ÍÍ ÈÈ	GÈÈ	ÈÈ	Á
UPØ	ÈÍÍ	ÈÍ€	ÈÈÈÈ	ÈH	ÈÈÈÈ	ÈÈÈÈ	ÈÈÈÈ	ÈÈÈÈ	ÈÈÈÈ	ÈÈÈÈ	ÈÈÈÈ	ÈH	ÈÍÍ	ÈÍH	ÈÈ	ÈÈÍ	ÈÍÍ

Ó[~}•ÁM|ãããÁQ&É
 UUÁQ|cÁFíí
 Ó[!|}ããÁQ&íí
 Q|FÁííÉí

Óã Á-Á[~}•Á^ã&@
 ÞÉJÁÚÉí
 ÓÉY KÁU&ã ÁQ[~}^çããÁQ&ãã[~}ã
 Y^ã&@:KÁU}}}

Óã Á-Á[~}•Á^ã&@ K&ÓÓííUÓÓT Ö
 ÞÉJÁÚÉí K&ÉÉÉÉÉÉÉÉF
 ÓÉY KÁU&ã ÁQ[~}^çããÁQ&ãã[~}ã K&HÞEFG
 Y^ã&@:KÁU}}}

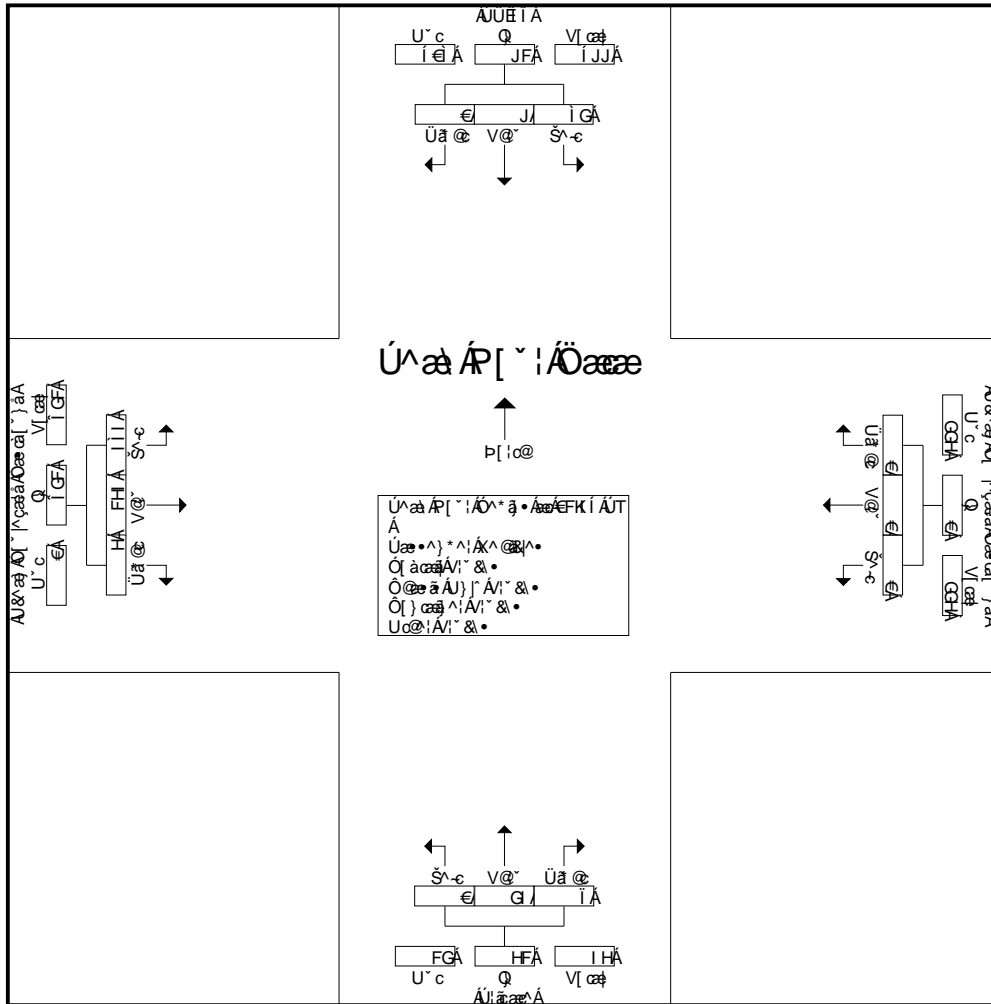

Úãã ÁP[~}!ÁÖããæ • Áãã ÁF K í ÁÚT Áãã ÁF K í ÁÚT Áãã ÁF K í ÁÚT
 Úãã ÁP[~}!ÁÖããæ • Áãã ÁF K í ÁÚT Áãã ÁF K í ÁÚT Áãã ÁF K í ÁÚT

	ÉFKEÁÚT				ÉFKEÁÚT				ÉFKEÁÚT				ÉFKEÁÚT			
ÉÉÁ á•É	26	5	€	31	€	€	€	€	€	F	G	H	127	G	F	Fíí
ÉFí Á á•É	GH	€	€	GH	€	€	€	€	€	i	F	i	FFí	40	€	Fíí
ÉHEÁ á•É	G	i	€	HF	€	€	€	€	€	i	4	FF	FGí	HG	€	FíJ
Éí Á á•É	G	H	€	G	€	€	€	€	€	10	G	12	FGF	FJ	28	168
V çãK[~}^	JJ	FH	€	FFG	€	€	€	€	€	G	J	H	IJF	FFí	GJ	íH
Á ÁH] ÉV çã	ííÉ	FFÉ	€	Á	€	€	€	€	€	iHÉ	GÉ	Á	íí	FíÉ	IÉ	Á
UPØ	ÉíG	Éí€	ÉÉÉÉ	ÉíH	ÉÉÉÉ	ÉÉÉÉ	ÉÉÉÉ	ÉÉÉÉ	ÉÉÉÉ	ÉÉG	ÉíH	ÉÉ	Éíí	ÉíH	ÉíJ	ÉíJ

Ó[~], ÁM|ā āáÁ&É
 ÚUÁÓ cÁFÍ
 Ó[~] āÁÓÁGÍ
 QIFDÍÉÍ

Óā Á-Á[~] *Á^ā@
 PÁUÁÚÉÍ
 ÓÉY ÁU&ā ÁÓ[~] ^çāáÁÓā cā[~] ā
 Y^ā@:ÁU}}^

Óā Áā ^ ÁÓÓÍ ÚÓÓÓ Ó
 Úā ÁÓ[~] ā ÁÉÉÉÉÉÉÉÉÉ
 Úā ÓÁā ÁÉÉÉÉÉÉÉÉÉ
 Úā ÁÁ[~] ÁÉ

Ó[~] •ÁUā cāÁÚā•^} *Á^Á^Á^

ÚāáÁÁ^	ÚÚÉÍ Ú[~] cā[~] ā				U&ā ÁÓ[~] ^çāáÁÓā cā[~] ā Y^•cā[~] ā				Úāāā P[~] cā[~] ā				U&ā ÁÓ[~] ^çāáÁÓā cā[~] ā				QāV[~]
	Š^c	V@	Úā @	Q ÉV[~]	Š^c	V@	Úā @	Q ÉV[~]	Š^c	V@	Úā @	Q ÉV[~]	Š^c	V@	Úā @	Q ÉV[~]	
ÉFÉÉÁÚT	Í	G	€	J	€	€	€	€	€	€	F	F	FÍ	Í	€	G	H
ÉFKÍ ÁÚT	Í	I	€	FF	€	€	€	€	€	G	G	I	GG	Í	€	G	I H
ÉFKÉÁÚT	J	H	€	FG	€	€	€	€	€	G	G	G	QÉ	Í	F	GJ	I H
ÉFKÍ ÁÚT	Í	€	€	Í	€	€	€	€	€	G	F	H	FÍ	FF	G	HF	I F
V[~]	HÉ	J	€	HU	€	€	€	€	€	I	Í	FÉ	ÍÍ	HH	H	FFH	FÍ G
ÉGÉÉÁÚT	FÉ	Í	€	FÍ	€	€	€	€	€	Í	H	Í	GH	Í	€	GJ	Í G
ÉGKÍ ÁÚT	FF	G	€	FH	€	€	€	€	€	Í	G	FÉ	HG	FÉ	€	I G	Í Í
ÉGKÉÁÚT	H	€	€	H	€	€	€	€	€	€	€	€	G	Í	€	H	HU
ÉGKÍ ÁÚT	€	€	€	€	€	€	€	€	€	€	€	€	HU	Í	€	ÍÍ	ÍÍ
V[~]	G	Í	€	HF	€	€	€	€	€	FH	Í	FÍ	FGG	HÉ	€	FÍ G	QÉF
Ó!ā áÁV[~]	Í	FÍ	€	Í€	€	€	€	€	€	FÍ	FF	G	FJJ	ÍH	H	GÍ	HÍ H
Q[~]:&Á	ÍÍÉ	GGÉ	€	Á	€	€	€	Á	€	ÍÉ	HUÉ	Á	ÍÍÉ	GÉ	FÉ	Á	Á
V[~]	FÍÉ	ÍÉ	€	FJÉ	€	€	€	€	€	ÍÉ	H	ÍÉ	ÍÍÉ	FÍÉ	É	ÍH	

ÚāáÁÁ^	ÚÚÉÍ Ú[~] cā[~] ā				U&ā ÁÓ[~] ^çāáÁÓā cā[~] ā Y^•cā[~] ā				Úāāā P[~] cā[~] ā				U&ā ÁÓ[~] ^çāáÁÓā cā[~] ā				QāV[~]
	Š^c	V@	Úā @	Q ÉV[~]	Š^c	V@	Úā @	Q ÉV[~]	Š^c	V@	Úā @	Q ÉV[~]	Š^c	V@	Úā @	Q ÉV[~]	
Úāā Á[~] :Áā ā • ÁÓ[~] { ÁFKÍ ÁÚT Á ÉGKÉÁÚT Á Úāā ÁÁ-Á	Í	€	€	Í	€	€	€	€	€	G	F	H	FÍ	11	2	HF	I F
Úāā Á[~] :Áā ÁÓ[~] cāÁÓ cā^&ā } ÁÓ^ ā • Áā ÁFKÍ ÁÚT	FÉ	5	€	15	€	€	€	€	€	Í	3	Í	GH	Í	€	GJ	Í G
	11	G	€	FH	€	€	€	€	€	8	G	10	32	FÉ	€	42	65
	H	€	€	H	€	€	€	€	€	€	€	€	G	Í	€	H	HU
V[~] ÁÁ[~] V[~]	HF	Í	€	H	€	€	€	€	€	FÍ	Í	GF	FÉF	H	G	FH	FJÍ
Á ÁÁ[~] V[~]	ÍFÉ	FÍÉ	€	Á	€	€	€	Á	€	ÍFÉ	GÍÉ	Á	ÍHG	GÍÉ	FÉ	Á	Á
UPØ	ÉÉ	ÉÉ	€	ÉÉÉ	ÉÉÉ	ÉÉÉ	ÉÉÉ	ÉÉÉ	ÉÉÉ	ÉÍJ	ÉÉ	ÉG	ÉÍJ	ÉÉÍ	ÉÉ	ÉGF	ÉÍÍ

Ó[~] ÁM|ä äÁÁ&É
 ÚUÁÖ cÁFÍÍ
 Ó[~] äÖÖÁGÍÍ
 QIFDGiÉGi

Óä Á-Á[~] *ÁÁ&@
 ÞDUÁÚËÍ
 ÖY ÁÚ&ä Á[~] |^çäáÁÖä ä[~] ä
 Y ^ä@:ÁÚ}}^

Ö^ Áç ^ ÁÖÓÍÍ ÚÖÖ Ö
 Úä ÁÖ| ä^ ÁÖÖÖÖÖÖÖÖ
 Úçö Öä^ ÁÖÖÖÖÖÖÖÖ
 Úä^ Á[~] ÁÖ

Ö[~] • ÁÚ:ä çÁËÖÍ äçÁÁVÍ~ & •

ÚçöÁVä ^	ÚÛËÍ Ú[~] cÖ[~] } ä				U&ä ÁÖ[~] ^çäá Öä ä[~] } ä Y ^• ä[~] } ä				Ú:äçæ Þ[~] cÖ[~] } ä				U&ä ÁÖ[~] ^çäá Öä ä[~] } ä Öä ä[~] } ä				Q äV[~] çæ	
	Š^-c	V@^	Üä @	ç äV[~] çæ	Š^-c	V@^	Üä @	ç äV[~] çæ	Š^-c	V@^	Üä @	ç äV[~] çæ	Š^-c	V@^	Üä @	ç äV[~] çæ		
ÉFKÉÁÚT	I	€	€	I	€	€	€	€	€	€	€	€	€	€	€	€	G	
ÉFKÍ ÁÚT	G	€	€	G	€	€	€	€	€	€	F	F	€	F	€	I	I H	
ÉFKÉÁÚT	I	F	€	I	€	€	€	€	€	€	€	€	€	€	€	H	I H	
ÉFKÍ ÁÚT	J	€	€	J	€	€	€	€	€	€	H	€	H	€	€	I F	I H	
V[~] çæ	G€	F	€	G€	€	€	€	€	€	€	H	F	I	J	I €	€	F H	F I H
ÉGKÉÁÚT	I	€	€	I	€	€	€	€	€	€	G	F	H	G	F H	€	H U	I I
ÉGKÍ ÁÚT	I	€	€	I	€	€	€	€	€	€	F	€	F	H	F I	€	I J	I I
ÉGKÉÁÚT	€	F	€	F	€	€	€	€	€	€	€	€	€	H	J	€	I H	I I
ÉGKÍ ÁÚT	€	€	€	€	€	€	€	€	€	€	€	€	€	H	F H	€	I J	I J
V[~] çæ	J	F	€	F€	€	€	€	€	€	€	H	F	I	F H F	I J	€	F I €	F J I
Ö:ä áÁV[~] çæ	GJ	G	€	H F	€	€	€	€	€	€	I	G	I	G G	I J	€	H F I	H I
ç : & ÖÁ	J H É	I É	€	Á	€	€	€	€	€	€	I I	G	Á	I G	G	€	Á	Á
V[~] çæ	I É	É	€	I É	€	€	€	€	€	€	F É	É	G G	I I É	G É	€	I J É	

ÚçöÁVä ^	ÚÛËÍ Ú[~] cÖ[~] } ä				U&ä ÁÖ[~] ^çäá Öä ä[~] } ä Y ^• ä[~] } ä				Ú:äçæ Þ[~] cÖ[~] } ä				U&ä ÁÖ[~] ^çäá Öä ä[~] } ä Öä ä[~] } ä				Q äV[~] çæ	
	Š^-c	V@^	Üä @	ç äV[~] çæ	Š^-c	V@^	Üä @	ç äV[~] çæ	Š^-c	V@^	Üä @	ç äV[~] çæ	Š^-c	V@^	Üä @	ç äV[~] çæ		
U^ä ÁV[~] ^çäá	9	€	€	9	€	€	€	€	€	€	3	€	3	H F	F €	€	I F	I H
ÉGKÉÁÚT	I	€	€	I	€	€	€	€	€	€	G	1	H	G	F H	€	H U	I I
ÉGKÍ ÁÚT	I	€	€	I	€	€	€	€	€	€	F	€	F	35	14	€	49	54
ÉGKÉÁÚT	€	1	€	F	€	€	€	€	€	€	€	€	€	H	J	€	I H	I I
V[~] çæ	F I	F	€	F J	€	€	€	€	€	€	I	F	I	F G	I I	€	F I G	F J I
Á Á[~] V[~] çæ	J I É	I É	€	Á	€	€	€	€	€	€	I I É	F I É	Á	I H H	G É	€	Á	Á
UP Ø	É €	É €	É €	É G	É €	É €	É €	É €	É €	É €	É €	É €	É H	É €	É G	É €	É I	É F I

Ó[~], ÁM|á ááÁQ&É
 UUÁO|cÁFIÍ
 Ó[~] ááÁOÁGIÍ
 QIFDGIÉGI

Óá Á-Á[~]*Á^áá@
 PÁHÁUÜÉÍ
 ÓÉY ÁU&á Á[~] Á^ááÁOá á[~] á
 Y^áá@:ÁU}}}

Óá Áá ^ ÁÓÓIÍUÓÓT Ö
 Úá ÁO| á^ ÁÉÉÉÉÉÉÉ
 ÚááOáá ÁHÁHÉDEFG
 ÚááÁÁ[~] ÁF

Ó[~]*ÁUá ááÁOá áÁU}}Á[~]&•

ÚááÁÁ^	UUÉÍ Ú[~]á[~]á				U&á ÁO Á^ááÁOá á[~] á Y^•á[~] á				Úááá P[~]á[~] á				U&á ÁO Á^ááÁOá á[~] á Oá á[~] á				QáV[~]
	Š~c	V@~	Uá@	Q[~]ÉV[~]	Š~c	V@~	Uá@	Q[~]ÉV[~]	Š~c	V@~	Uá@	Q[~]ÉV[~]	Š~c	V@~	Uá@	Q[~]ÉV[~]	
ÉFKÉÁÚT	I	€	€	I	€	€	€	€	€	€	€	€	FÍ	Í	€	GF	G
ÉFKÍ ÁÚT	F	€	€	F	€	€	€	€	€	€	€	€	J	í	€	FI	FÍ
ÉFKÉÁÚT	G	€	€	G	€	€	€	€	€	€	€	€	FÍ	I	€	GG	G
ÉFKÍ ÁÚT	G	€	€	G	€	€	€	€	€	F	€	F	HG	í	€	HJ	I G
V[~]	J	€	€	J	€	€	€	€	€	F	€	F	ÍI	GG	€	JÍ	FÉ
ÉGKÉÁÚT	I	€	€	I	€	€	€	€	€	€	€	€	HÍ	H	€	IF	IÍ
ÉGKÍ ÁÚT	H	€	€	H	€	€	€	€	€	€	€	€	G	í	€	HF	H
ÉGKÉÁÚT	€	€	€	€	€	€	€	€	€	€	€	€	HG	í	€	HÍ	HÍ
ÉGKÍ ÁÚT	€	€	€	€	€	€	€	€	€	€	€	€	GH	€	FI	HÍ	HÍ
V[~]	í	€	€	í	€	€	€	€	€	€	€	€	FFÍ	FÍ	FI	FÍI	FÍI
Ó!á áÁ[~]	FÍ	€	€	FÍ	€	€	€	€	€	F	€	F	FJF	HÍ	FI	G H	G €
Q[~]:&Á	Fé€	€	€	Á	€	€	€	Á	€	Fé€	€	Á	ííÉ	FíÉ	íÉ	Á	Á
V[~]	íÉ	€	€	íÉ	€	€	€	€	€	éÉ	€	éÉ	ííÉ	FíÉ	íÉ	JHÉ	

ÚááÁÁ^	UUÉÍ Ú[~]á[~]á				U&á ÁO Á^ááÁOá á[~] á Y^•á[~] á				Úááá P[~]á[~] á				U&á ÁO Á^ááÁOá á[~] á Oá á[~] á				QáV[~]
	Š~c	V@~	Uá@	Q[~]ÉV[~]	Š~c	V@~	Uá@	Q[~]ÉV[~]	Š~c	V@~	Uá@	Q[~]ÉV[~]	Š~c	V@~	Uá@	Q[~]ÉV[~]	
Úáá Á[~]:Á[~]á[~]•Á[~]Á[~]ÉFKÍ ÁÚT Á[~]ÉGKÉÁÚT Á[~]Uáá Á[~]Á[~]Á[~]																	
Úáá Á[~]:Á[~]Á[~]á[~]Á[~]•Á[~]Á[~]Á[~]ÉFKÍ ÁÚT	G	€	€	G	€	€	€	€	€	1	€	1	HG	7	€	HJ	I G
ÉGKÉÁÚT	4	€	€	4	€	€	€	€	€	€	€	€	38	H	€	41	45
ÉGKÍ ÁÚT	H	€	€	H	€	€	€	€	€	€	€	€	G	í	€	HF	H
ÉGKÉÁÚT	€	€	€	€	€	€	€	€	€	€	€	€	HG	í	€	HÍ	HÍ
V[~]Á[~]Á[~]Á[~]Á[~]	J	€	€	J	€	€	€	€	€	F	€	F	FÍ	GH	€	FÍJ	FÍJ
Á Á[~]ÉV[~]	Fé€	€	€	Á	€	€	€	Á	€	Fé€	€	Á	ííÉ	FíÉ	€	Á	Á
UPØ	ÉÍH	ÉÉÉ	ÉÉÉ	ÉÍH	ÉÉÉ	ÉÉÉ	ÉÉÉ	ÉÉÉ	ÉÉÉ	ÉÉ€	ÉÉÉ	ÉÉ€	ÉGJ	ÉGF	ÉÉÉ	ÉÉJ	ÉÍH

Ó[~], ÁM|ā āáQ&É
 ÚUÁÓ cÁFI
 Ó[~] āāÓÓÁGíí
 QI FDI Ē Ē Ē

Óā Á-Á[~] * Á^ā&@
 P&UÁÚĒ Ē
 ÓĒY KÁU&ā ÁÓ[~] ^cāāÁÓā cā[~] ā
 Y ^ā&@:KÁU}}}

Óā Áā ^ K&ÓÓ Ē UÓÓ Ē
 Úā ÁÓ Ē K&ĒĒĒĒĒĒ
 Úāā Óāā K&ĒĒĒĒĒĒ
 Úāā Á[~] K&Ē

Ó[~] • ÁU|ā cāāĒÓ[~] āā ^ÁV[~] &•

ÚāāÁVā ^	ÚÚĒ Ē Ú[~] cā[~] ā				U&ā ÁÓ[~] ^cāā Óāā cā[~] ā Y ^• cā[~] ā				Ú[~] āāā P[~] cā[~] ā				U&ā ÁÓ[~] ^cāā Óāā cā[~] ā				QāV[~] ā
	Š^c	V@	Ūā @	Q[~] ĒV[~] ā	Š^c	V@	Ūā @	Q[~] ĒV[~] ā	Š^c	V@	Ūā @	Q[~] ĒV[~] ā	Š^c	V@	Ūā @	Q[~] ĒV[~] ā	
ĒFKĒĒÁÚT	I	€	€	I	€	€	€	€	€	€	€	€	€	€	€	€	G
ĒFKÍ ÁÚT	F	€	€	F	€	€	€	€	€	€	€	€	€	€	€	€	Fí
ĒFKĒÁÚT	G	€	€	G	€	€	€	€	€	€	€	€	€	€	€	€	G
ĒFKÍ ÁÚT	G	€	€	G	€	€	€	€	€	F	€	F	HG	Ī	€	HJ	I G
V[~] ā	J	€	€	J	€	€	€	€	€	F	€	F	ĪĪ	GG	€	JĪ	FĒ
ĒKĒĒÁÚT	I	€	€	I	€	€	€	€	€	€	€	€	HĪ	H	€	IF	I Ī
ĒKÍ ÁÚT	H	€	€	H	€	€	€	€	€	€	€	€	G	Ī	€	HF	H
ĒKĒÁÚT	€	€	€	€	€	€	€	€	€	€	€	€	HG	Ī	€	HĪ	HĪ
ĒKÍ ÁÚT	€	€	€	€	€	€	€	€	€	€	€	€	GH	€	FI	HĪ	HĪ
V[~] ā	Ī	€	€	Ī	€	€	€	€	€	€	€	€	FFĪ	FĪ	FI	FIĪ	FIĪ
Ó[~] āÁV[~] ā	FĪ	€	€	FĪ	€	€	€	€	€	F	€	F	FJF	HĪ	FI	GH	G Ē
Q[~] Ī&@	FĒĒ	€	€	Ā	€	€	€	Ā	€	FĒĒ	€	Ā	ĪĪĒ	FĪĒ	ĪĒ	Ā	Ā
V[~] ā	ĪĒ	€	€	ĪĒ	€	€	€	€	€	ĒĒ	€	ĒĒ	ĪĒĒ	FĪĒ	ĪĒ	JĒĒ	

ÚāāÁVā ^	ÚÚĒ Ē Ú[~] cā[~] ā				U&ā ÁÓ[~] ^cāā Óāā cā[~] ā Y ^• cā[~] ā				Ú[~] āāā P[~] cā[~] ā				U&ā ÁÓ[~] ^cāā Óāā cā[~] ā				QāV[~] ā
	Š^c	V@	Ūā @	Q[~] ĒV[~] ā	Š^c	V@	Ūā @	Q[~] ĒV[~] ā	Š^c	V@	Ūā @	Q[~] ĒV[~] ā	Š^c	V@	Ūā @	Q[~] ĒV[~] ā	
Úāā Á[~] Īāā ā • ā ÁÓ[~] { ĒFKÍ ÁÚT Ē ĒKĒĒÁÚT Ē Úāā Á[~] Īāā ā																	
Úāā Á[~] Īāā ā (ÁÓ[~] cāāQā) ÁÓ[~] ā • ā ĒFKÍ ÁÚT	G	€	€	G	€	€	€	€	€	1	€	1	HG	7	€	HJ	I G
ĒKĒĒÁÚT	4	€	€	4	€	€	€	€	€	€	€	€	38	H	€	41	45
ĒKÍ ÁÚT	H	€	€	H	€	€	€	€	€	€	€	€	G	Ī	€	HF	H
ĒKĒÁÚT	€	€	€	€	€	€	€	€	€	€	€	€	HG	Ī	€	HĪ	HĪ
V[~] āÁ[~] { ^	J	€	€	J	€	€	€	€	€	F	€	F	FĪ	GH	€	FIJ	FĪJ
Ā Á[~] ĒV[~] ā	FĒĒ	€	€	Ā	€	€	€	Ā	€	FĒĒ	€	Ā	ĪĪĒ	FĪĒ	€	Ā	Ā
UPØ	ĒĪH	ĒĒĒ	ĒĒĒ	ĒĪH	ĒĒĒ	ĒĒĒ	ĒĒĒ	ĒĒĒ	ĒĒĒ	ĒĪ€	ĒĒĒ	ĒĪ€	ĒĪG	ĒĪG	ĒĒĒ	ĒĪJ	ĒĪH

Ö[~], ÁM|ä ä^áQ&É
 UUÁÖ cÁFIÍ
 Ö[~] äÖÖÁGÍÍ
 QIFDÍÍÉÍ

Öä Á-Ä[~] *Á^æ&@
 ÞHJÁUÜËÍ
 ÖEY KÁU&ä Ö[~] |^ççääÖæ cá[~] ä
 Y^æ@:KÁ[~]}}

Ö^Áæ ^ KÖÖÍ UÖÖ Ö
 Üä ÁÖ[~] ä^ KÖÖÖÖÖÖF
 ÜççÖÖæ KÖÖÖÖÖÖF
 Üæ^Á[~] KÖ

Ö[~] • ÁUä ç^áUc@:ÁI^ & •

ÜççÖÁÜ ^	ÜÜË Í Ú[~] cÖ[~] } á				U&ä Ö[~] ^ççää Öæ cá[~] } á Y^æ cá[~] } á				Ú:äæ P[~] cÖ[~] } á				U&ä Ö[~] ^ççää Öæ cá[~] } á				Q çÁV[~] çæ
	Š^c	V@^	Üä @	ç ÆV[~] çæ	Š^c	V@^	Üä @	ç ÆV[~] çæ	Š^c	V@^	Üä @	ç ÆV[~] çæ	Š^c	V@^	Üä @	ç ÆV[~] çæ	
ÆKÉÁÜT	FE	€	€	FE	€	€	€	€	€	€	€	€	F	F	€	G	FG
ÆKÍ ÁÜT	ì	€	€	ì	€	€	€	€	€	€	€	€	G	F	€	H	FF
ÆKÉÁÜT	ì	F	€	J	€	€	€	€	€	F	€	F	F	ì	€	ì	Fì
ÆKÍ ÁÜT	H	€	€	H	€	€	€	€	€	€	€	€	F	€	€	F	I
V[~] çæ	GJ	F	€	H€	€	€	€	€	€	F	€	F	ì	ì	€	FH	II
EGKÉÁÜT	H	€	€	H	€	€	€	€	€	€	€	€	G	G	F	ì	ì
EGKÍ ÁÜT	H	F	€	ì	€	€	€	€	€	F	€	F	F	G	€	H	ì
EGKÉÁÜT	ì	€	€	ì	€	€	€	€	€	€	€	€	F	H	€	ì	FE
EGKÍ ÁÜT	ì	€	€	ì	€	€	€	€	€	€	€	€	€	€	€	€	ì
V[~] çæ	Fì	F	€	FJ	€	€	€	€	€	F	€	F	ì	ì	F	FG	HG
Ö[~] ä ÁV[~] çæ	ì Ì	G	€	ì J	€	€	€	€	€	G	€	G	J	Fì	F	G	ì Ì
ç :&ÖÁ	Jì È	ì È	€	Á	€	€	€	€	€	FE	€	Á	Hì	ì €	ì	Á	Á
V[~] çæ	ì È	GÈ	€	ì È	€	€	€	€	€	GÈ	€	GÈ	FFÈ	FJÈ	FÈ	HGÈ	

ÜççÖÁÜ ^	ÜÜË Í Ú[~] cÖ[~] } á				U&ä Ö[~] ^ççää Öæ cá[~] } á Y^æ cá[~] } á				Ú:äæ P[~] cÖ[~] } á				U&ä Ö[~] ^ççää Öæ cá[~] } á				Q çÁV[~] çæ
	Š^c	V@^	Üä @	ç ÆV[~] çæ	Š^c	V@^	Üä @	ç ÆV[~] çæ	Š^c	V@^	Üä @	ç ÆV[~] çæ	Š^c	V@^	Üä @	ç ÆV[~] çæ	
Üä ÁV[~] : ÁV[~] çæ	H	€	€	H	€	€	€	€	€	€	€	€	F	€	€	F	ì
Üä ÁV[~] : ÁV[~] çæ	H	€	€	H	€	€	€	€	€	€	€	€	2	G	1	5	ì
Üä ÁV[~] : ÁV[~] çæ	H	1	€	ì	€	€	€	€	€	1	€	1	F	G	€	H	ì
Üä ÁV[~] : ÁV[~] çæ	6	€	€	6	€	€	€	€	€	€	€	€	F	3	€	ì	10
V[~] çæ	Fì	F	€	Fì	€	€	€	€	€	F	€	F	ì	ì	F	FH	H€
Á ÁV[~] ÈV[~] çæ	JHÈ	ì ÈG	€	Á	€	€	€	€	€	FE	€	Á	Hì È	ì È	ì È	Á	Á
UPØ	È G	È €	È€€€	È Ì	È€€€	È€€€	È€€€	È€€€	È€€€	È €	È€€€	È €	È G	È Ì H	È €	È Ì €	È Ì €

Ó[~},◦ÁM|ã,ãáAQ&É
 UUÁQ]cAFfi
 Ó[!:]ãÖÖÁGii
 QIFDÁiÈđi

Óã Á-Á[~}*Á^ã&@
 PÐJAJUËi
 ÖEY KÁU&ã ÁQ[~|^çãáÁÖã cá[~}á
 Y^ã&@:KÁU}}^

Qã Ápã ^ KÖÓi i UÖÖT Ö
 Úã ÁQ] á^ KÉÉÉÉÉÉÉF
 ÚãáÖãá KÁHBEFG
 Úã Áp[KÍG

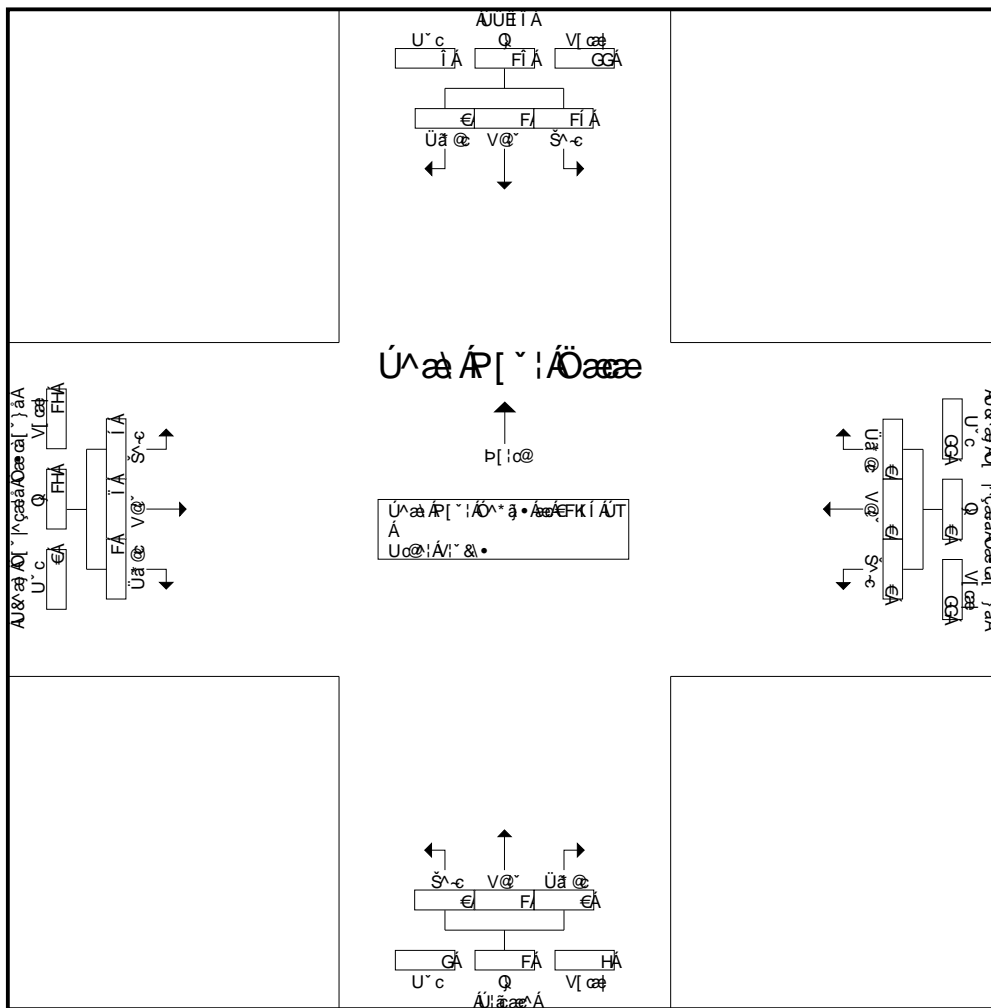

Úãá ÁP[~|^ÖÖãæ • á ÁQ[~|^çãáÁÖã cá[~}á
 Úãá ÁP[~|^|^ÖÖãæ • ÁK

	EFKÍ ÁÚT				EFKÍ ÁÚT				EFKÍ ÁÚT				EFKÍ ÁÚT			
ÉÉÁ á•È	H	€	€	H	€	€	€	€	€	€	€	€	F	€	€	F
ÉFí Á á•È	H	€	€	H	€	€	€	€	€	€	€	€	2	G	1	5
ÉHEÁ á•È	H	1	€	l	€	€	€	€	€	1	€	1	F	G	€	H
Éí Á á•È	6	€	€	6	€	€	€	€	€	€	€	€	F	3	€	l
V[çã]K[~ ^	Fí	F	€	Fí	€	€	€	€	€	F	€	F	í	í	F	FH
Á ÁQ] ÁV[çã]	JHÈ	î ÈG	€	Á	€	€	€	Á	€	FEE	€	Á	H È	í È	í È	Á
UPØ	È ÈG	È È	È È	È È	È È	È È	È È	È È	È È	È È	È È	È È	È ÈG	È ÈH	È È	È È

Ó[~}•ÁM|ãããÁQ&É
 UUÁQ]cÁFíí
 Ó[!|]ããÁQ&íí
 QíFÁííÉí

Óã Á-Á[~]•ÁQ&ã@
 ÞÉUÁUÜÉí
 ÓÉY KÁU&ã ÁQ[~]cãããÁQ&ãã[~]ã
 Y^ãã@:KÁU}}}

QÁ Áã ^ K&ÓÓííUÓÚT
 Úã ÁQ]ã^ K&ÉÉÉÉÉÉF
 ÚããÓãã K&ÞÉDEFG
 Úãã^Á[K&G

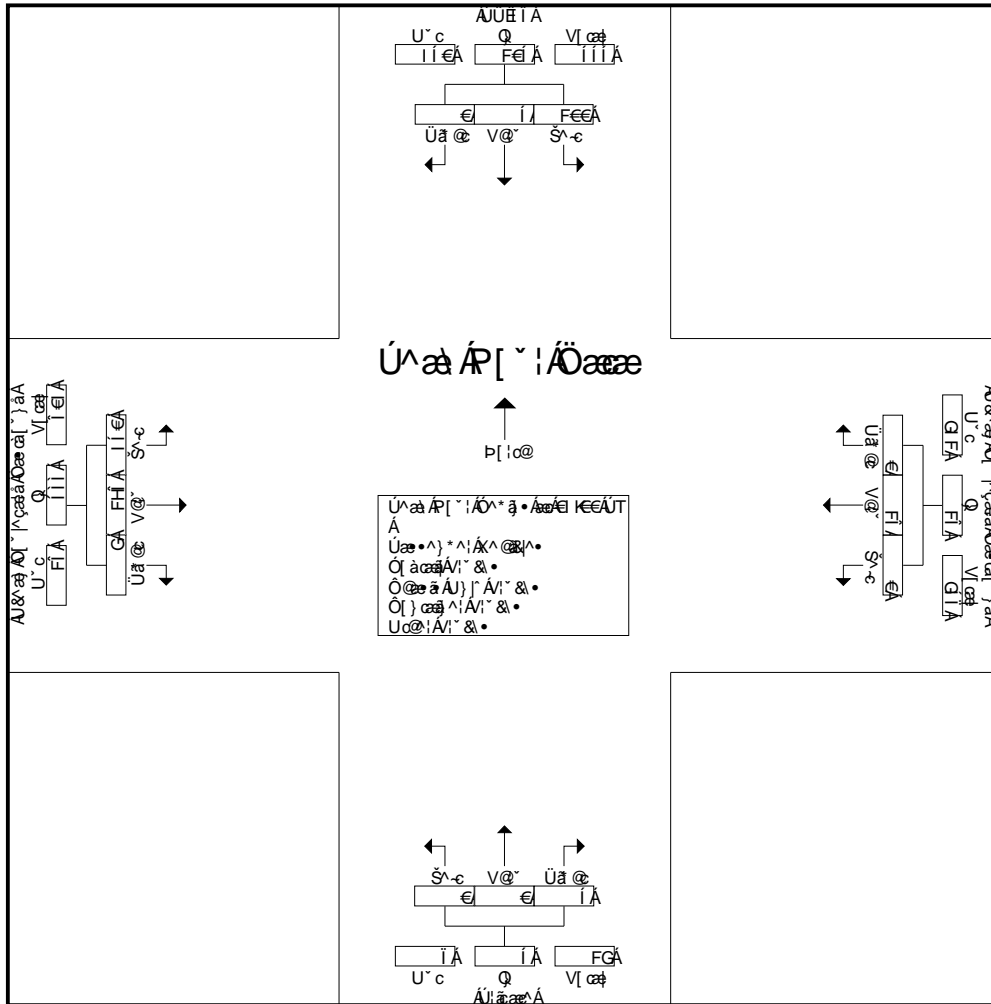

Úã ÁR[~]!ÁQ&ã•ÁQ[~]cãããÁQ&ãã[~]ã K&ÉÚT Áí Áí Kí ÁÚT ÁUãã ÁÁ-Á
 Úã ÁR[~]!Á[~]!ÁQ&ãã[~]ã[~]!ãã@ÁQ^ã•ÁãK

ÉÉÁ á•É	GG	€	€	GG	€	í	€	í	€	€	4	4	138	GJ	€	167	
ÉFí Á á•É	II	3	€	47	€	6	€	6	€	€	€	€	FH	HF	€	Fíí	
ÉHÁ á•É	IF	H	€	II	€	í	€	í	€	€	3	€	H	Jí	HG	2	FGJ
Éí Á á•É	47	€	€	II	€	€	€	€	€	€	F	F	G	íH	44	€	FĜ
V[ç]K[~]c^	Fíí	í	€	Fí€	€	Fí	€	Fí	€	€	í	í	J	íí€	FHí	G	ííí
Á ÁQ]ÉV[ç]	JíÉ	HÉ	€	Á	€	FÉ€	€	Á	€	€	ííÉ	ííÉ	Á	ííÉ	GHE	€H	Á
UPØ	ÉÉFJ	É€€	É€€€	ÉíF	É€€€	Éíí	É€€€	Éíí	É€€€	ÉíH	ÉFH	ÉíH	ÉFí	ÉíH	É€	Éí€	Éí€

Ó[~},oAM|ã,ãã&E
 UUÁ[ç&FFí
 Ó[í:]ã&ÖÁGíí
 QíFÁíEí

Óã Á-Á[~}*Á^ã&
 ÐEJÁUÛEí
 ÖEY KÁU&ã Á[~]^çããÁÖããã[~}ã
 Y^ã&@:KÁU}}~

ÖÁ Áã ^ KÖÓÍí UÖÖÚT
 Üã ÁÖ[ã^ KÉÉÉÉÉÉÉF
 Üãã Öãã KÁEÐEFG
 Üã^Á[KÍG

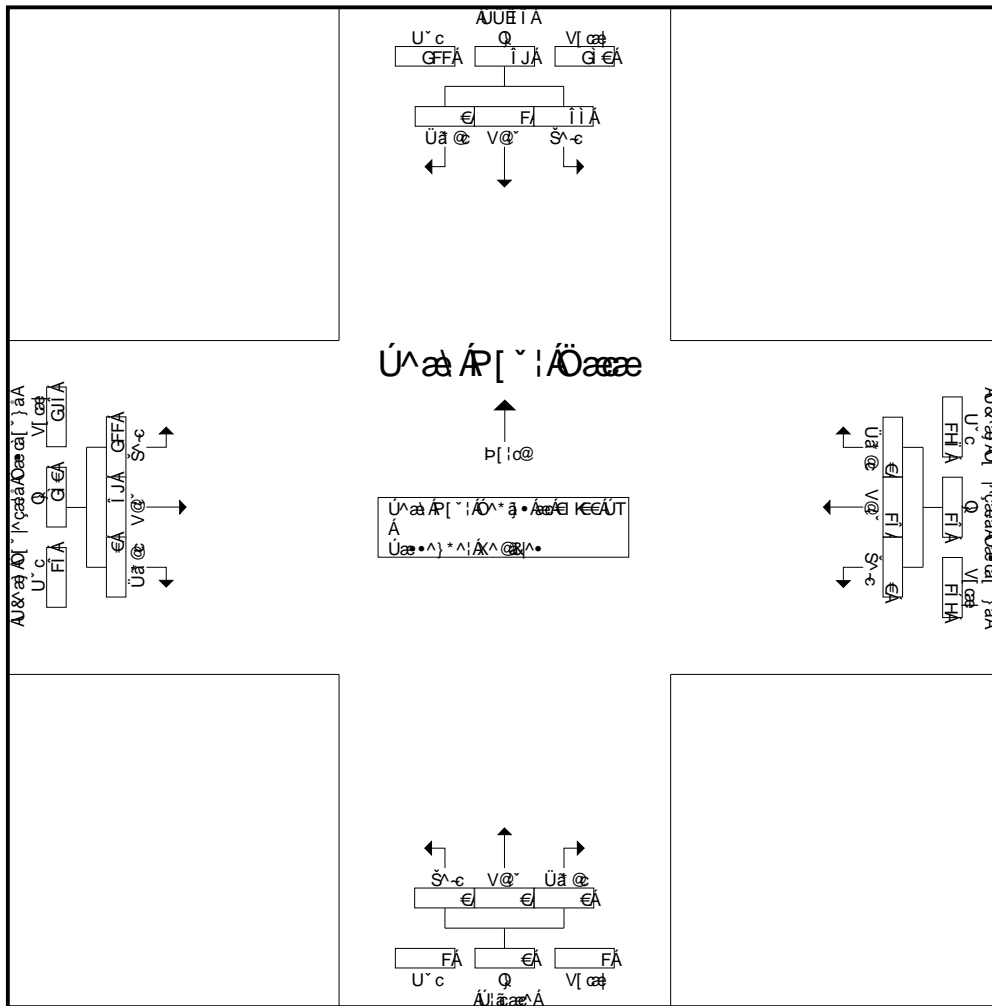

Úã ÁR[~]!Öãæã •ã Á[~] ÁE KEEÚT ÁE ÁE KÍ ÁÚT ÁE Úã ÁR[~]!
 Úã ÁR[~]! Á[~] Öãã ÖÁ[~]!|!ã ÖÁ^ã •ã ÁEK

	eí KEEÚT	eí KEEÚT	eí KEEÚT	eí KEEÚT
ÉÉÁ ã •É	í 1 € J	€ í € í	€ € € €	íí € íH
ÉFÍ Á ã •É	FJ € € FJ	€ 6 € 6	€ € € €	€ Fí € íí
ÉHEÁ ã •É	FH € € FH	€ í € í	€ € € €	€ í€ FJ € íJ
Éí Á ã •É	28 € € 28	€ € € €	€ € € €	€ 61 31 € 92
V[ç]K[~]^	íí F € íJ	€ Fí € Fí	€ € € €	€ GFF íJ € G€
Á ÁÖ[~]EÁV[ç]	JíE FÉ € Á	€ FEE € Á	€ € € €	€ ííE GÉ € Á
UPØ	EÉ € EÉ€ EÉ€ EÉ€ EÉ€	EÉ€ EÉ€ EÉ€ EÉ€ EÉ€	EÉ€ EÉ€ EÉ€ EÉ€ EÉ€	EÉ€ EÉ€ EÉ€ EÉ€ EÉ€

Ô[~ } , • Á M | á , á á Á Q & E
 UUÁQ | c Á F F I I
 Ô[! :] } á á Ô Á Á G I I
 Q I F D G I E G I

Ô á Á - Á [] * Á ^ á á @
 P B U Á U Ü È I
 O E Y K Á U & á á Á Ô [^ ' ^ ç á á Á Ô á á (~) á
 Y ^ á á @ ! K Á U } } ^

Ô Á Á á ^ K S O I I U Ô Ò Ú T
 Ú á Á Ô [á á K E C E C E E E F
 Ú á á Á Ô á á K H B D E F G
 Ú á á Á Á [K G

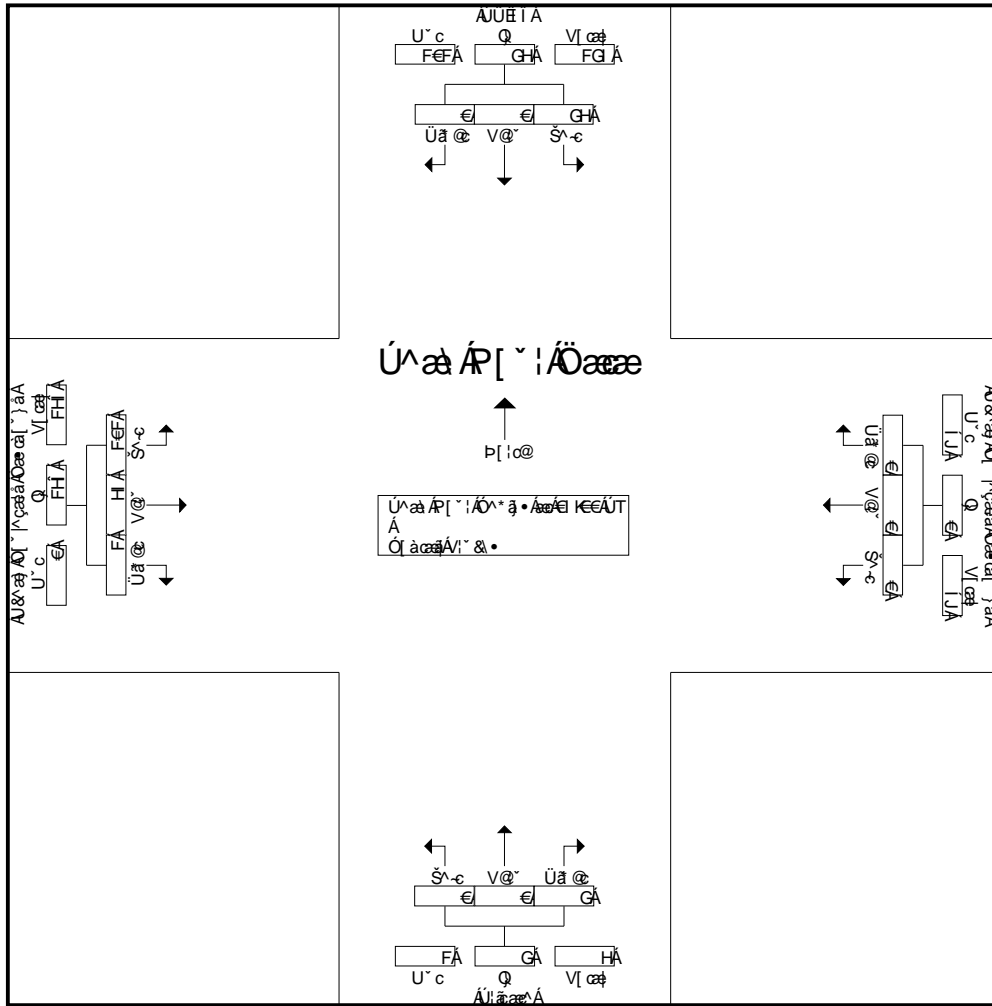

Ú á á Á P [~ ! Á Ô á á á Á Á I { Á i K E Á Ú Á Á i K I Á Ú Á Á Ú á á Á Á Á - Á
 Ú á á Á P [~ ! Á I Á Ô á á Á Ô [! :] } á á Ô Á Á G I I

	ei KEEÁÚT				ei KEEÁÚT				ei KEEÁÚT				ei KEEÁÚT			
ÉĒÁ á • É	G	€	€	G	€	€	€	€	€	€	€	€	39	11	€	50
ÉFÁ Á á • É	G	€	€	G	€	€	€	€	€	€	1	1	HG	FF	€	I H
ÉĤÁ Á á • É	i	€	€	i	€	€	€	€	€	€	F	F	FJ	I	€	G
ÉÍÁ Á á • É	11	€	€	11	€	€	€	€	€	€	€	€	FF	i	€	FJ
V [c Ā] [~ { ^	GH	€	€	GH	€	€	€	€	€	€	G	G	FĔF	H	F	FĤ
Á Á [Ĥ] [Ė] [c Ā]	FĔĔ	€	€	Á	€	€	€	Á	€	€	FĔĔ	Á	Ī ĪĤ	G	€Ī	Á
Ú P Ø	Ī Ī GH	Ī Ī ĔĔ	Ī Ī ĔĔ	Ī Ī GH	Ī Ī ĔĔ	Ī Ī ĔĔ	Ī Ī ĔĔ	Ī Ī ĔĔ	Ī Ī ĔĔ	Ī Ī ĔĔ	Ī Ī ĔĔ	Ī Ī ĔĔ	Ī Ī Ī	Ī Ī H	Ī Ī €	Ī Ī €

Ö[] ÖÁM | ä äáQ&É
 UUÁÖ cÁFI
 Ö[] äÖÖÁGII
 QI FDG i È G I

Öä Á -Á[] * Á^æ&@
 ÞEUKÁUËË I
 ÖEY KÁU&ä ÁÖ[] ^ççääÁÖæ cá[] ä
 Y ^æ@:KÁU } }

ÖÁ Áæ ^ KÖÖI i UÖÖUT
 Üæ ÁÖ[] ä^ KÉÉÉÉÉÉÉÉÉÉ
 ÜççÖÖæ KÁEÞEFG
 Üæ ^ Á[] KÁ

Ö[] • ÁÜä ç ä È Ö ä ÁU } Á/ ^ & •

ÜççÖÖÁÜ ^	ÜÜÈ Ì Û[] cÖ[] } ä				U&ä ÁÖ[] ^ççää Öæ cá[] } ä Y ^ ç ç ä[] } ä				Ü: äæ Þ[] cÖ[] } ä				U&ä ÁÖ[] ^ççää Öæ cá[] } ä Öæ cá[] } ä				Q ç Á[] ç
	Š^c	V@	Üä @	ç ÈV ç	Š^c	V@	Üä @	ç ÈV ç	Š^c	V@	Üä @	ç ÈV ç	Š^c	V@	Üä @	ç ÈV ç	
È KÉÁÜT	€	€	€	€	€	€	€	€	€	€	€	€	H	F	€	ì	ì
È KÍ ÁÜT	F	€	€	F	€	€	€	€	€	€	€	€	ì	F	€	ì	ì
È KÈÁÜT	€	€	€	€	€	€	€	€	€	€	€	€	ì	G	€	ì	ì
È KÍ ÁÜT	€	F	€	F	€	€	€	€	€	€	€	€	F	€	€	F	G
V[] ç	F	F	€	G	€	€	€	€	€	€	€	€	FH	ì	€	Fì	FJ
È KÉÁÜT	€	€	€	€	€	€	€	€	€	€	F	F	F	€	€	F	G
È KÍ ÁÜT	F	€	€	F	€	€	€	€	€	€	€	€	€	F	€	F	G
È KÈÁÜT	€	€	€	€	€	€	€	€	€	F	€	F	F	€	€	F	G
È KÍ ÁÜT	€	€	€	€	€	€	€	€	€	€	€	€	F	G	€	H	H
V[] ç	F	€	€	F	€	€	€	€	€	F	F	G	H	H	€	ì	J
Ö! ä á Á[] ç	G	F	€	H	€	€	€	€	€	F	F	G	Fì	ì	€	GH	Gì
ç] : & @	ì Ì È	H È È	€	Á	€	€	€	€	€	ì €	ì €	Á	ì J È	H È È	€	Á	Á
V[] ç	ì È	H È	€	F È È	€	€	€	€	€	H È	H È	ì È	ì Ì È	G	€	ì G È	

ÜççÖÖÁÜ ^	ÜÜÈ Ì Û[] cÖ[] } ä				U&ä ÁÖ[] ^ççää Öæ cá[] } ä Y ^ ç ç ä[] } ä				Ü: äæ Þ[] cÖ[] } ä				U&ä ÁÖ[] ^ççää Öæ cá[] } ä Öæ cá[] } ä				Q ç Á[] ç	
	Š^c	V@	Üä @	ç ÈV ç	Š^c	V@	Üä @	ç ÈV ç	Š^c	V@	Üä @	ç ÈV ç	Š^c	V@	Üä @	ç ÈV ç		
È KÉÁÜT	€	€	€	€	€	€	€	€	€	€	€	€	H	F	€	ì	ì	
È KÍ ÁÜT	1	€	€	1	€	€	€	€	€	€	€	€	5	F	€	6	7	
È KÈÁÜT	€	€	€	€	€	€	€	€	€	€	€	€	ì	2	€	ì	ì	
È KÍ ÁÜT	€	1	€	F	€	€	€	€	€	€	€	€	F	€	€	F	G	
V[] ç	F	F	€	G	€	€	€	€	€	€	€	€	FH	ì	€	Fì	FJ	
Á Á[] ÈV[] ç	ì €	ì €	€	Á	€	€	€	€	€	€	€	€	ì Ì È	G È È	€	Á	Á	
UP Ø	È €	È €	È € €	È € €	È € €	È € €	È € €	È € €	È € €	È € €	È € €	È € €	È € €	È € €	È € €	È € €	È € €	È € €

Üæ Á[] : Á[] ä Á[] { Á KÉÁÜT Á KÍ ÁÜT ÁU ä Á Á - Á
 Üæ Á[] : Á[] Á[] ä Á[] ^ & ä } Á ^ ä • Á Á KÉÁÜT

Ó[] , o ÁM |ã, äããQ&É
 UUÁO] cÁFíí
 Ó[] :] äÖÖÁGíí
 Qí FÁGí É Gí

Óã Á -Á[] * ÁO^æ&
 ÞEYKÁUÛÉí
 ÖEY KÁU&æ] ÁO[] ^çæãÁÖæ cá[] ä
 Y ^æ@:KÁU } } ^

QÁ Á ç ^ KÖÓíí U ÖÚT
 Úæ ÁO] ä^ KÉÉÉÉÉÉF
 Úæã Öæ^ KÁ B DEFG
 Úæ ^ Á[KÍG

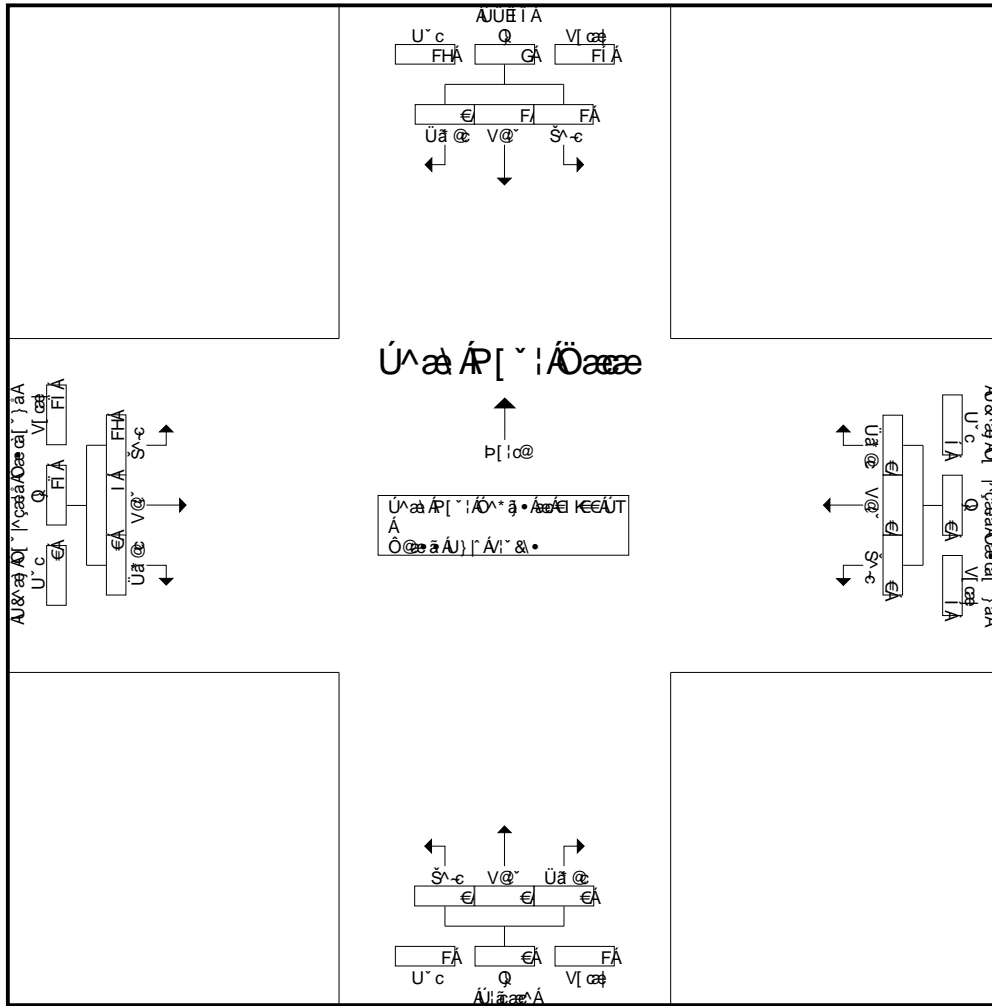

Úæ ÁR[] ^ í Öææ
 Úæ ÁR[] ^ í Öææ

	ei keeÚT				ei keeÚT				ei keeÚT				ei keeÚT			
ÉÉÁ ä •É	€	€	€	€	€	€	€	€	€	€	€	€	H	F	€	I
ÉFí Á ä •É	1	€	€	1	€	€	€	€	€	€	€	€	5	F	€	6
ÉHEÁ ä •É	€	€	€	€	€	€	€	€	€	€	€	€	1	2	€	í
Éí Á ä •É	€	1	€	F	€	€	€	€	€	€	€	€	F	€	€	F
V[çæ]K[] ^	F	F	€	G	€	€	€	€	€	€	€	€	FH	I	€	Fí
Á ÁH] ÉV[çæ]	í	€	í	€	€	€	€	€	€	€	€	€	í í É	GÉ	€	Á
UPØ	É €	É €	ÉÉÉ	É €	ÉÉÉ	ÉÉÉ	ÉÉÉ	ÉÉÉ	ÉÉÉ	ÉÉÉ	ÉÉÉ	ÉÉÉ	É í €	É €	ÉÉÉ	É é

Ö[~]•ÁM|ä ä^áQ&É
 UUÁÖ cÁFIÍ
 Ö[~]•áÖÖÁGÍÍ
 QIFDÍÉÍ

Öá Á-Á[~]•Á^á&@
 ÞDUÁUÜÉÍ
 ÖEY ÁU&á Ö[~]•Á^ááÁÖá á[~]•á
 Y^á&@:ÁU}}^

ÖÁ Áá ^ ÁÖÖÍ UÖÖÚT
 Üá ÁÖ á^ ÁÉÉÉÉÉÉÉ
 Üá ÖÖá ÁÉÉÉÉÉÉÉ
 Üá ÁÁ[~]•Á

Ö[~]•ÁUá áÁÁUc@ÁÍ^&•

ÜáÖÁVá ^	ÜÜÉÍ Ú[~]•c@[~]•á				U&á ÁÖ[~]•Á^áá Öá á[~]•á Y^•á[~]•á				Úááá P[~]•c@[~]•á				U&á ÁÖ[~]•Á^áá Öá á[~]•á				Q.áV[~]•á
	Š~c	V@~	Üá @	Q[~]•V[~]•á	Š~c	V@~	Üá @	Q[~]•V[~]•á	Š~c	V@~	Üá @	Q[~]•V[~]•á	Š~c	V@~	Üá @	Q[~]•V[~]•á	
É KEÁÚT	€	€	€	€	€	€	€	€	€	€	G	G	I	I	€	J	FF
É KÍ ÁÚT	€	F	€	F	€	€	€	€	€	€	€	€	I	F	€	í	í
É KHEÁÚT	€	€	€	€	€	€	€	€	€	€	F	F	H	G	€	í	í
É KÍ ÁÚT	€	F	€	F	€	€	€	€	€	€	€	€	€	G	€	G	H
V[~]•á	€	G	€	G	€	€	€	€	€	€	H	H	FF	F€	€	GF	Ğ
É KEÁÚT	€	€	€	€	€	€	€	€	€	€	F	F	G	F	€	H	I
É KÍ ÁÚT	G	€	€	G	€	€	€	€	€	€	€	€	€	G	€	G	I
É KHEÁÚT	F	€	€	F	€	€	€	€	€	€	€	€	€	€	€	€	F
É KÍ ÁÚT	€	€	€	€	€	€	€	€	€	€	F	F	F	€	€	F	G
V[~]•á	H	€	€	H	€	€	€	€	€	€	G	G	H	H	€	í	FF
Ö!á áÁV[~]•á	H	G	€	í	€	€	€	€	€	€	í	í	FI	FH	€	Ğ	H Á
Q[~]•:Á&@	í€	í€	€	Á	€	€	€	Á	€	€	F€€	Á	íFÈ	ííÈ	€	Á	Á
V[~]•á	íÈ	íÈ	€	FÈÈ	€	€	€	€	€	€	FÈÈ	FÈÈ	HÈÈ	HÈÈ	€	íH	

ÜáÖÁVá ^	ÜÜÉÍ Ú[~]•c@[~]•á				U&á ÁÖ[~]•Á^áá Öá á[~]•á Y^•á[~]•á				Úááá P[~]•c@[~]•á				U&á ÁÖ[~]•Á^áá Öá á[~]•á				Q.áV[~]•á
	Š~c	V@~	Üá @	Q[~]•V[~]•á	Š~c	V@~	Üá @	Q[~]•V[~]•á	Š~c	V@~	Üá @	Q[~]•V[~]•á	Š~c	V@~	Üá @	Q[~]•V[~]•á	
Üáá Á[~]•ÁÖ[~]•á	€	€	€	€	€	€	€	€	€	€	2	2	4	5	€	9	11
É KEÁÚT	€	€	€	€	€	€	€	€	€	€	€	€	I	F	€	í	í
É KÍ ÁÚT	€	1	€	1	€	€	€	€	€	€	€	€	H	G	€	í	í
É KHEÁÚT	€	€	€	€	€	€	€	€	€	€	F	F	H	G	€	í	í
É KÍ ÁÚT	€	F	€	F	€	€	€	€	€	€	€	€	€	G	€	G	H
V[~]•á	€	G	€	G	€	€	€	€	€	€	H	H	FF	F€	€	GF	Ğ
Á ÁÖ[~]•ÁV[~]•á	€	F€€	€	Á	€	€	€	Á	€	€	F€€	Á	íGÈ	ííÈ	€	Á	Á
UPØ	È€€	È€€	È€€	È€€	È€€	È€€	È€€	È€€	È€€	È€€	ÈÍ	ÈÍ	ÈÍ	ÈÈ€	È€€	ÈÍH	ÈJF

Ö[~}, ◦ ÁM|ã, äããQ&É
UUAÖj ◦ ÁFFi
Ö[!:] äãÖÖVÖi
QI FÖi i È ð i

Öã Á -Á[] * Á^ã&@
PÖUÄJÜÈ i
ÖEY KÄU&ã ÁÖ[~ | ^çããÁÖããã[~] ä
Y ^ã&@:KÄU } } ^

Ö^ Áã ^ KÖÖi i U ÖÖU
Üã ÁÖ[ä ^ KEEEEEEF
ÜããÖãã K H B D E F G
Üã ^ Á [K G

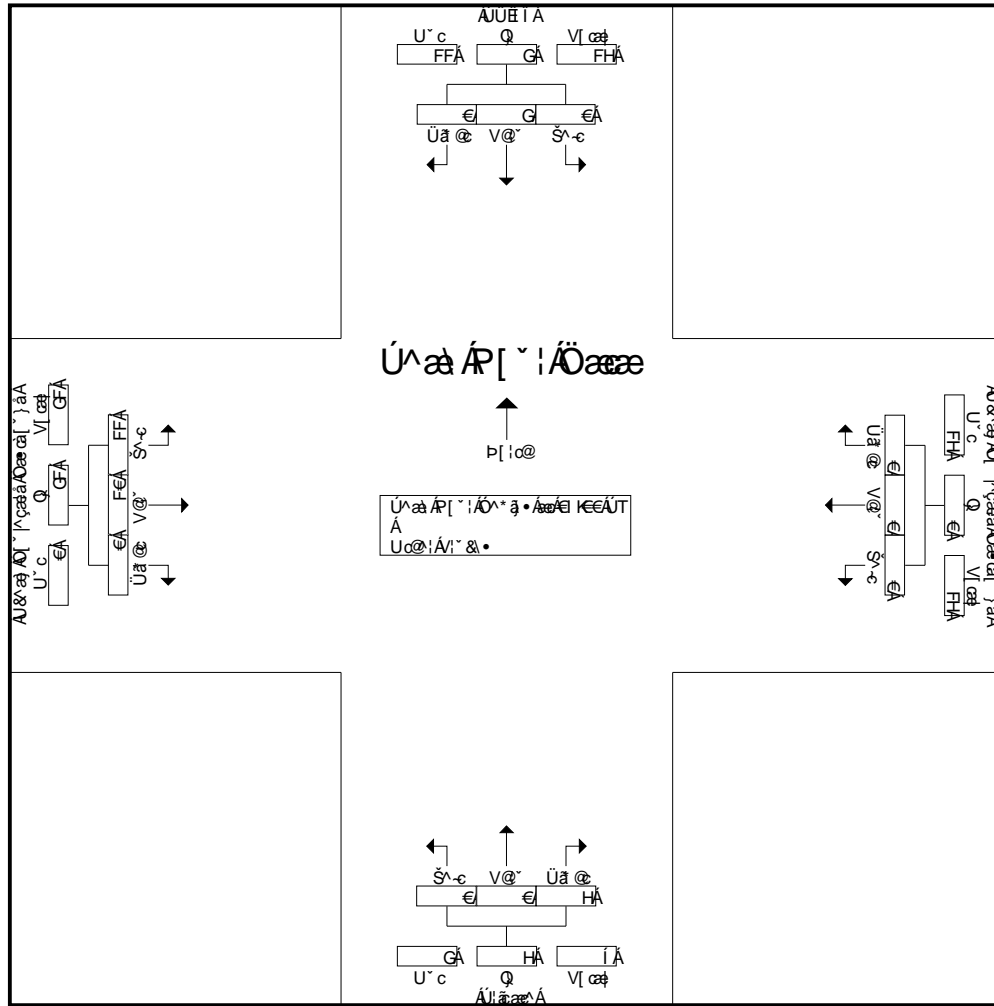

Úãã ÁR[~ | ÁÖããã • ÁÖ[!:] Ái KEEÁUT Ái Ái K i ÁUT ÁÜãã Á Á Á
Úãã ÁR[~ | Ái | ÁÖããã[~] |!:] äãÖÖVÖi • ÁããK

	ei keeÁUT				ei keeÁUT				ei keeÁUT				ei keeÁUT			
ÉéÁ ä • È	€	€	€	€	€	€	€	€	€	€	2	2	4	5	€	9
ÉFí Á ä • È	€	1	€	1	€	€	€	€	€	€	€	€	l	F	€	i
ÉHé Á ä • È	€	€	€	€	€	€	€	€	€	€	F	F	H	G	€	í
Éi í Á ä • È	€	F	€	F	€	€	€	€	€	€	€	€	€	G	€	G
VI çãK[~] { ^	€	G	€	G	€	€	€	€	€	€	H	H	FF	F€	€	GF
Á ÁÖ[] ÁV[çã	€	F€€	€	Á	€	€	€	Á	€	€	F€€	Á	í GÉ	í í È	€	Á
UPÖ	€€€	È €€	€€€	È €€	€€€	€€€	€€€	€€€	€€€	€€€	È i í	È i í	È i í	È €€	€€€	È i H

Ó[~}•óÁM|ããããQ&É
 UUÁQ|cÁFFÍ
 Ó[!|}ããããGÍÍ
 Q|FÁG|ÉÍÍ

Óã Á-Á[~}•Á^ã&@
 ÞEJ|KÁã:ÁU|CÉ^}^
 ÓEY KÁU&ã ÁQ|~|çããÁ Á•cà[~}ã
 Y^ã&@:KÁ|}}^

ÓE^Áã ^ KÓÓÓUQÓY CÉ
 Úã ÁQ|ã KÉÉÉÉÉÉÉÉÉ
 ÚããÁÓãã KÁÞBDEFG
 Úãã^Á[K&

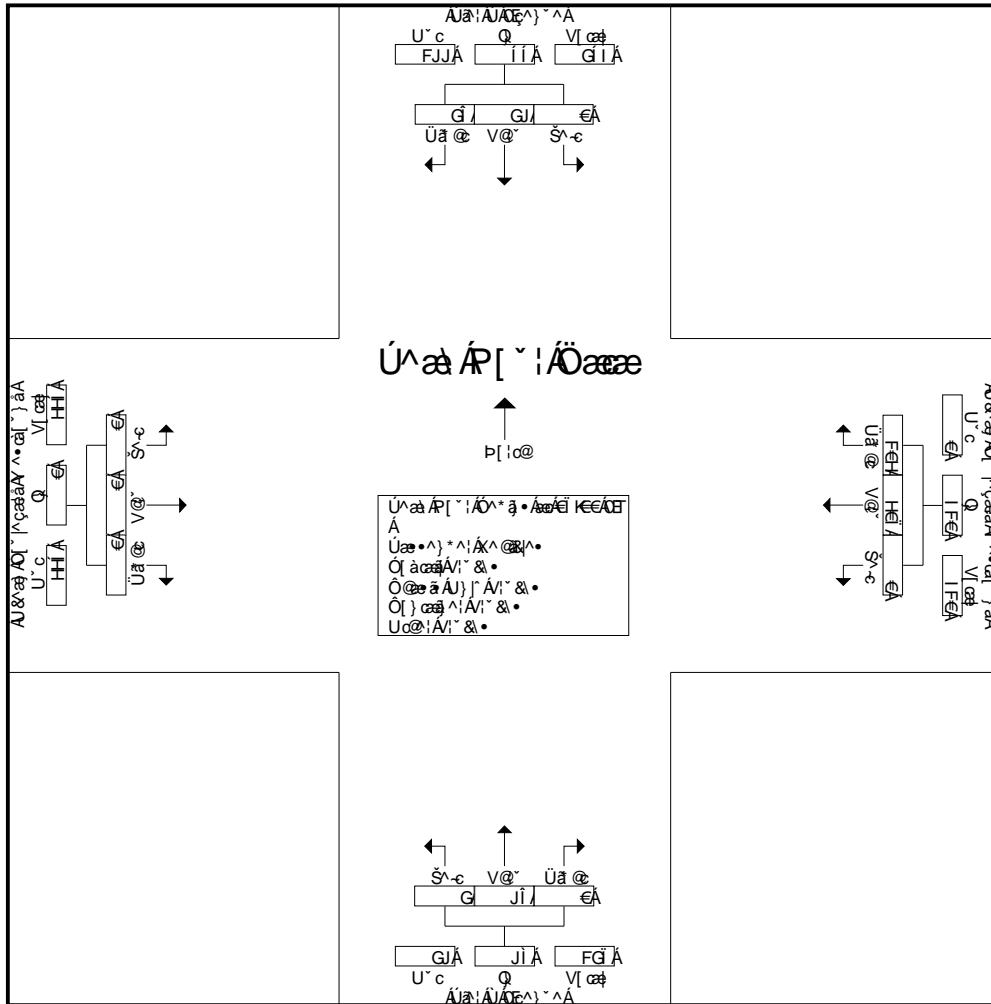

Úã ÁR[~}!Öãæ •ã ÁQ|{ ÁÍ KÉCÉ ÁÍ KÍ ÁCÉ ÁU^ã ÁÁ-Á
 Úã ÁR[~}!Á|ÖããQ|!|ãã@Á^ã•Á&K

	éí kÉCÉ				éí kÉCÉ				éí kÉCÉ				éí kÉCÉ			
ÉéÁ á•É	€	Fí	Fí	HG	€	83	GF	FÉ	€	GH	€	GH	€	€	€	€
ÉFÍ Á á•É	€	í	17	G	€	íJ	Fí	Jí	€	29	€	29	€	€	€	€
ÉHÉ Á á•É	€	18	í	G	€	íí	G	FÉ€	1	QÉ	€	GF	€	€	€	€
ÉÍ Á á•É	€	Fí	Fí	33	€	í€	39	109	F	G	€	G	€	€	€	€
V çãK ~}^	€	í€	íí	FFÍ	€	HÉ	FÉH	I FÉ	G	Jí	€	Jí	€	€	€	€
Á ÁQ ÉV çã	€	íG	ííÉ	Á	€	ííÉ	GíÉ	Á	G	Jí	€	Á	€	€	€	€
UPQ	€€€	ÉHH	ÉÉJ	ÉÍF	€€€	ÉG	Éí€	Éí€	É€€	ÉG	€€€	Éíí	€€€	€€€	€€€	€€€

Ó[~]•ÁM|ããáÁ&É
 ÚUÁÓçAFÍI
 Ó[~]ã&ÓçÁGÍI
 QIFDÍÈGÍ

Óã Á-Á[~]*Á^ã&@
 ÞEUIÁÚÁÚÁÚÁÚÁÚÁ
 ÓEY KÁÚ&ãÁÓ[~]çãáÁ^•cá[~]á
 Y^ã&@:KÁ[~]}^

ÓE^Áã^ K&ÓÓÚÓÓY ÓE
 ÚãÁÓ[~]á K&E&E&E&E&E
 Úã&Óã K&E&E&E&E
 Úã^Á[~] K&E

Ó[~]•ÁÚããá&Úã•^}*^ÁK^@E^•

Úã&ÓÁ^	Úã:ÁÚÁÚÁÚÁÚÁ Ú[~]cá[~]á				U&^ãÁÓ[~]çãá Y^•cá[~]á Y^•cá[~]á				Úã:ÁÚÁÚÁÚÁÚÁ P[~]cá[~]á				U&^ãÁÓ[~]çãá Y^•cá[~]á Óãcá[~]á				Qcá[~]cá
	Š^c	V@~	Úã@	Q[~]ÉV[~]cá	Š^c	V@~	Úã@	Q[~]ÉV[~]cá	Š^c	V@~	Úã@	Q[~]ÉV[~]cá	Š^c	V@~	Úã@	Q[~]ÉV[~]cá	
É K&E&E	€	F	H	I	€	Í€	FÍ	ÍÍ	€	GF	€	GF	€	€	€	€	F&G
É KÍÁ	€	Í	Í	FG	€	ÍÍ	FH	ÍF	€	GG	€	GG	€	€	€	€	F&Í
É K&E&E	€	H	Í	Í	€	ÍÍ	FG	ÍÍ	F	FÍ	€	FJ	€	€	€	€	JÍ
É KÍÁ	€	G	G	I	€	HJ	G	ÍI	F	FÍ	€	FÍ	€	€	€	€	ÍÍ
V[~]cá	€	FG	FÍ	G	€	GFH	ÍÍ	G€	G	ÍÍ	€	ÍJ	€	€	€	€	HÍ
É K&E&E	€	Í	F€	FÍ	€	GF	Í	G	€	I	€	I	€	€	€	€	ÍÍ
É KÍÁ	€	€	J	J	€	GG	Í	G	€	I	€	I	€	€	€	€	I€
É K&E&E	€	H	G	Í	€	FÍ	Í	GH	F	H	€	I	€	€	€	€	HG
É KÍÁ	€	H	Í	Í	€	FÍ	Í	G	€	J	€	J	€	€	€	€	IH
V[~]cá	€	FG	G	H	€	ÍÍ	G	F&I	F	G€	€	GF	€	€	€	€	FÍH
Ó!ãáÁ[~]cá	€	G	IG	ÍÍ	€	GJF	JH	HÍ	H	JÍ	€	F&E	€	€	€	€	ÍÍ€
Q[~]!&@	€	HÍÈ	ÍHÈ	Á	€	ÍÍÈ	GÈ	Á	H	JÍ	€	Á	€	€	€	€	Á
V[~]cá	€	IÈ	ÍÈ	FG	€	ÍG	FÍÈ	ÍJÈ	ÈÈ	FÍÈ	€	FÍÈ	€	€	€	€	Á

Úã&ÓÁ^	Úã:ÁÚÁÚÁÚÁÚÁ Ú[~]cá[~]á				U&^ãÁÓ[~]çãá Y^•cá[~]á Y^•cá[~]á				Úã:ÁÚÁÚÁÚÁÚÁ P[~]cá[~]á				U&^ãÁÓ[~]çãá Y^•cá[~]á Óãcá[~]á				Qcá[~]cá	
	Š^c	V@~	Úã@	Q[~]ÉV[~]cá	Š^c	V@~	Úã@	Q[~]ÉV[~]cá	Š^c	V@~	Úã@	Q[~]ÉV[~]cá	Š^c	V@~	Úã@	Q[~]ÉV[~]cá		
Úã&Á[~]!Á&E	€	F	H	I	€	60	FÍ	77	€	GF	€	GF	€	€	€	€	F&G	
Úã&Á[~]!Á&E	€	6	6	12	€	ÍÍ	FH	ÍF	€	22	€	22	€	€	€	€	105	
Úã&Á[~]!Á&E	€	H	Í	Í	€	ÍÍ	FG	ÍÍ	1	FÍ	€	FJ	€	€	€	€	JÍ	
Úã&Á[~]!Á&E	€	G	G	I	€	HJ	25	ÍI	F	FÍ	€	FÍ	€	€	€	€	ÍÍ	
V[~]cáK[~]!^	€	FG	FÍ	G	€	GFH	ÍÍ	G€	G	ÍÍ	€	ÍJ	€	€	€	€	HÍ	
ÁÁ[~]ÉV[~]cá	€	IÈ	ÍÈ	Á	€	ÍÍÈ	GÈ	Á	GÈ	JÍÈ	€	Á	€	€	€	€	Á	
UPØ	ÈÈÈ	ÈÈÈ	ÈÈÈ	ÈÈÈ	ÈÈÈ	ÈÈÈ	ÈÈÈ	ÈÈÈ	ÈÈÈ	ÈÈÈ	ÈÈÈ	ÈÈÈ	ÈÈÈ	ÈÈÈ	ÈÈÈ	ÈÈÈ	ÈÈÈ	ÈÈÈ

Ó[~}oÁM|ãããã&É
 UUÁO|cÁFíí
 Ó[!|}ããããGíí
 Q|FÁGíÉí

Óã Á-Á[]*Á^ã&
 ÞÐJKA:AUÁE^)^
 ÖY KA&ã ÁO[]^çããÁ ^•cã[~}ã
 Y^ã@:KA}}^

ÖY Áã ^ KÓÓÚWÓY ÖF
 Úã ÁO[á^ KEEEEEEF
 ÚããÁÖãã KÁÞBDEFG
 Úãã^Á[K&

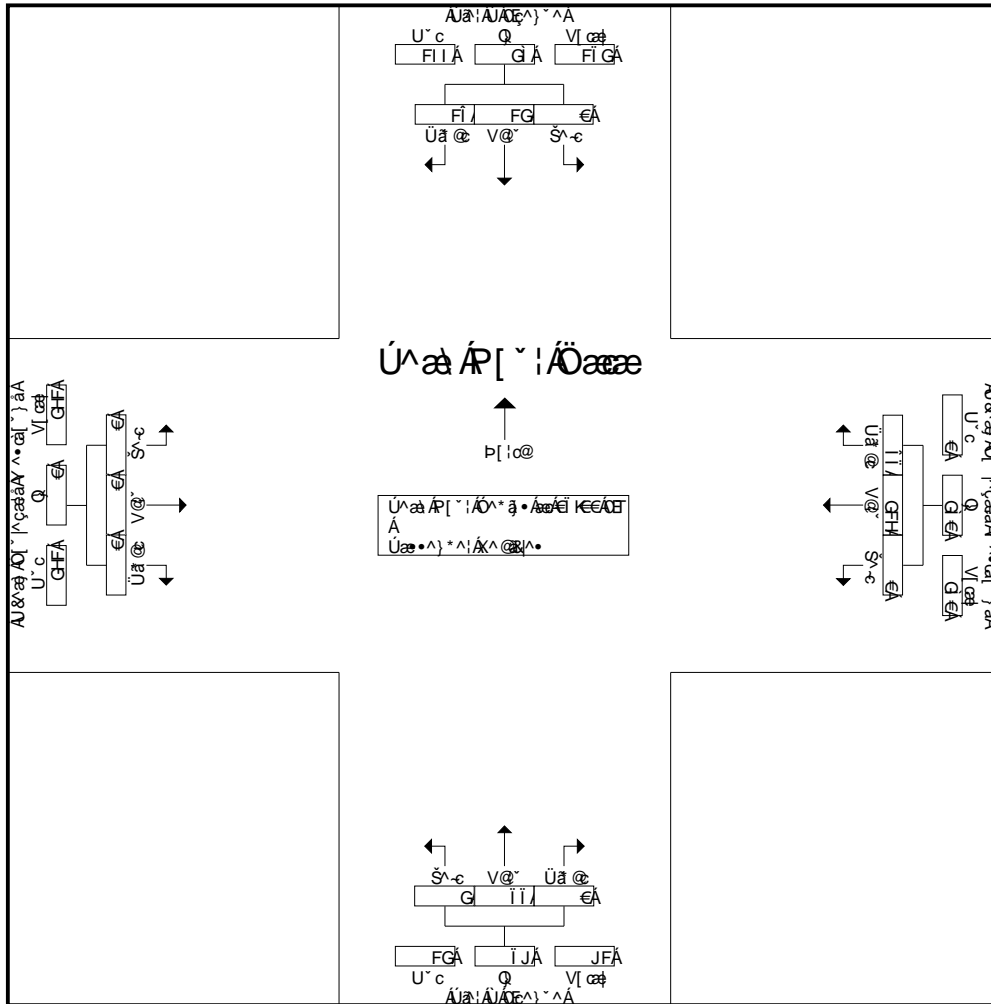

Úã ÁR[~}!Öãæ *ã ÁO[] Kí Kí ÖF ÁÚ^ã ÁÁ-Á
 Úã ÁR[~}!Á[ÖããÖÍ]!ããÖ^ã•ÁãK

	éi keeÖF				éi keeÖF				éi keeÖF				éi keeÖF			
ÉéÁ á•É	€	F	H	I	€ 60	Fí	77	€	GF	€	GF	€	€	€	€	
ÉFí Á á•É	€	6	6	12	€	íí	FH	€	22	€	22	€	€	€	€	
ÉHé Á á•É	€	H	i	i	€	íí	FG	€	1	€	FJ	€	€	€	€	
ÉíÁ á•É	€	G	G	I	€	HU	25	€	F	€	Fí	€	€	€	€	
V[öðK[]{ ^	€	FG	Fí	G	€	GFH	íí	€	G	€	íí	€	íJ	€	€	
Á ÁÖÍ]ÉV[öð	€	I GÉ	ííÉ	Á	€	ííÉ	G-É	€	GÉ	€	JíÉ	€	€	€	€	
UPÖ	€€€	É€€	Éíí	ÉíH	€€€	Éíí	Éí€	É€J	€€€	Éíí	€€€	É€J	€€€	€€€	€€€	

Ó[]·óÁM jã ãáÁQ&É
 UUÁÖ cAFÍÍ
 Ó[]ãäÖÖGÍÍ
 QIFDÖ iÉ ðÍ

Óã Á-Å[]*Á^ã&@
 PBUJÅ:ÁÚÅ}^
 ÖY KÅ&ã ÁÖ[]^çãáÁ ^•çã[] á
 Y^ã&@:KÅ[]}

ÖY Áã ^ KÖÓÓÚÓY ÖF
 Úã ÁÖ[] á KÉÉÉÉÉÉF
 Úã áÖã KÅBDEFG
 Úã ÁÁ[] KÅ

Ö[]·ÁÚã çáÉÖÍ áãÁVÍ~&•

ÚãçãÁ^ ^	Úã:ÁÚÅ}^ ^ Ú[]çã[] á				U&ã ÁÖ[]^çãá Y^•çã[] á Y^•çã[] á				Úã:ÁÚÅ}^ ^ P[]çã[] á				U&ã ÁÖ[]^çãá Y^•çã[] á Öãçã[] á				Q çã[]
	Š^-c	V@~	Üã @	Ç ÉV çã	Š^-c	V@~	Üã @	Ç ÉV çã	Š^-c	V@~	Üã @	Ç ÉV çã	Š^-c	V@~	Üã @	Ç ÉV çã	
É KÉÖF	€	G	€	G	€	J	F	F€	€	F	€	F	€	€	€	€	FH
É KÍ ÖF	€	F	€	F	€	FF	€	FF	€	Í	€	Í	€	€	€	€	FÍ
É KÉÖF	€	€	F	F	€	J	H	FG	€	€	€	€	€	€	€	€	FH
É KÍ ÖF	€	G	F	H	€	FÍ	I	FJ	€	F	€	F	€	€	€	€	GH
V çã	€	Í	G	Í	€	ÍÍ	I	ÍG	€	Í	€	Í	€	€	€	€	ÍÍ
É KÉÖF	€	G	G	I	€	FÍ	H	FÍ	€	F	€	F	€	€	€	€	GH
É KÍ ÖF	€	€	F	F	€	GG	F	GH	€	€	€	€	€	€	€	€	G
É KÉÖF	€	€	H	H	€	G	Í	GJ	€	F	€	F	€	€	€	€	HH
É KÍ ÖF	€	Í	G	Í	€	GH	H	GÍ	€	G	€	G	€	€	€	€	HÍ
V çã	€	Í	Í	FÍ	€	ÍÍ	FG	JÍ	€	Í	€	Í	€	€	€	€	FFÍ
Ö:ã áÁV çã	€	FH	F€	GH	€	FQ	QE	FÍ	€	FG	€	FG	€	€	€	€	FÍ H
Ç]: & @ Å	€	Í Í	Í H	Á	€	Í Í	F H	Á	€	F € €	€	Á	€	€	€	€	Á
V çã Å	€	Í	Í	FG	€	Í J	F €	Í €	€	Í	€	Í	€	€	€	€	Á

ÚãçãÁ^ ^	Úã:ÁÚÅ}^ ^ Ú[]çã[] á				U&ã ÁÖ[]^çãá Y^•çã[] á Y^•çã[] á				Úã:ÁÚÅ}^ ^ P[]çã[] á				U&ã ÁÖ[]^çãá Y^•çã[] á Öãçã[] á				Q çã[]
	Š^-c	V@~	Üã @	Ç ÉV çã	Š^-c	V@~	Üã @	Ç ÉV çã	Š^-c	V@~	Üã @	Ç ÉV çã	Š^-c	V@~	Üã @	Ç ÉV çã	
Úã ÁV]: Å çã	€	2	€	G	€	J	F	F€	€	F	€	F	€	€	€	€	FH
Úã ÁV]: Å çã	€	F	€	F	€	FF	€	FF	€	6	€	6	€	€	€	€	FÍ
Úã ÁV]: Å çã	€	€	1	F	€	J	H	FG	€	€	€	€	€	€	€	€	FH
Úã ÁV]: Å çã	€	G	F	3	€	15	4	19	€	F	€	F	€	€	€	€	23
V çã K[]^ ^	€	Í	G	Í	€	ÍÍ	I	ÍG	€	Í	€	Í	€	€	€	€	ÍÍ
Á ÖV] ÉV çã	€	Í F	G	Á	€	Í Í	F Í	Á	€	F € €	€	Á	€	€	€	€	Á
UP Ø	€ € €	€ €	€ €	€ € H	€ € €	€ € H	€ € €	€ € Í	€ € €	€ € H	€ € €	€ € H	€ € €	€ € €	€ € €	€ € €	€ € G

Ó[~}oÁM|ããããQ&E
 UUÁQ|cÁFíí
 Ó[í:]ããÖÖÁGíí
 QíFíGííEíí

Óã Á -Áí } * ÁOã&@
 ÞEUIÁUã:ÁUÁE^ } ^
 ÖEY KÁU&ã ÁQí } |^çããÁ ^•cã[~} á
 Y ^ã@:KÁU } }

ÖE^ Áã ^ KÖÓÓUWÓY ÖE
 Úã ÁQí á^ KEEEEEEF
 Úãã ÖÖã KÁE BDEFG
 Úãã ^ ÁQí K&

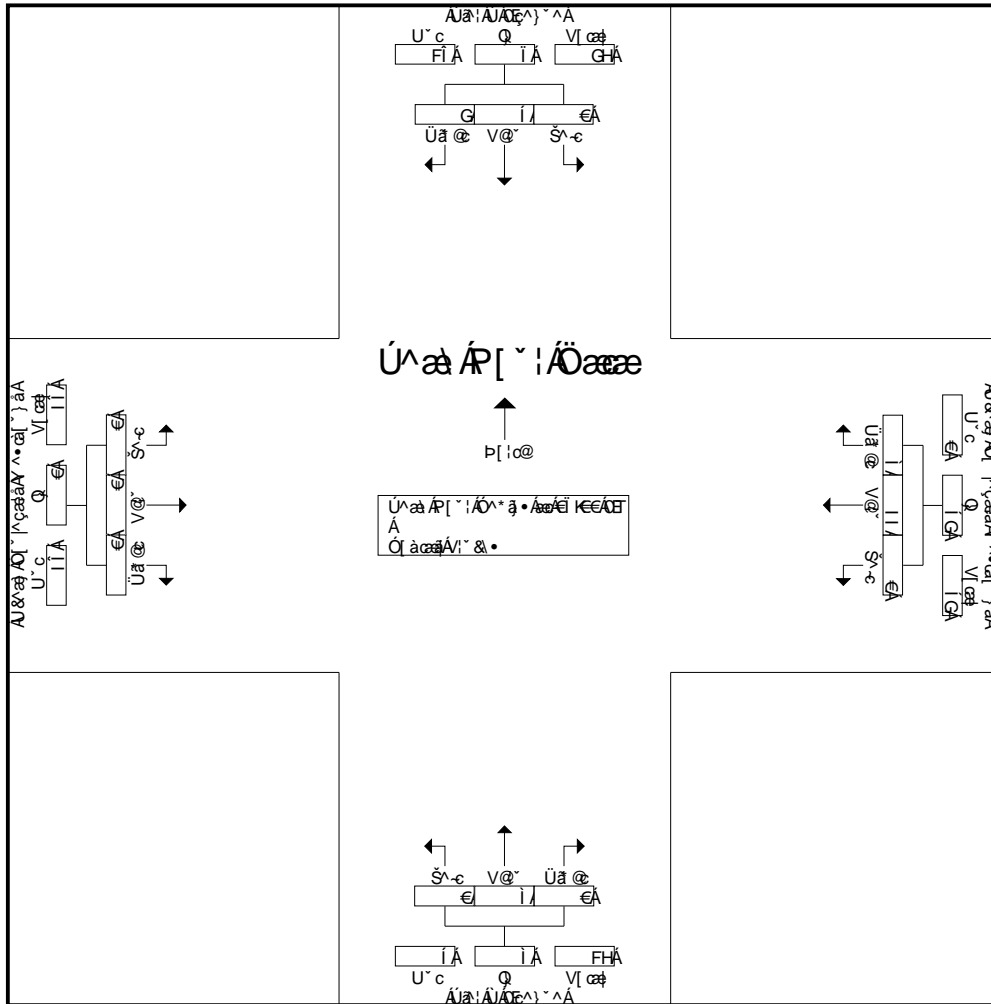

Úãã ÁR[~}íÖÖãæ } * ÁQí } |^çããÁ ^•cã[~} á
 Úãã ÁR[~}íÖÖãæ } |^çããÁ ^•cã[~} á

	eí keeÖE				eí keeÖE				eí keeÖE				eí keeÖE			
ÉeÁ á•É	€	2	€	G	€	J	F	€E	€	F	€	F	€	€	€	€
ÉFí Á á•É	€	F	€	F	€	FF	€	FF	€	6	€	6	€	€	€	€
ÉHEÁ á•É	€	€	1	F	€	J	H	FG	€	€	€	€	€	€	€	€
Éí Á á•É	€	G	F	3	€	15	4	19	€	F	€	F	€	€	€	€
V cãK[í^	€	í	G	í	€	íí	í	íG	€	í	€	í	€	€	€	€
Á ÁQí EÁV cã	€	íFÉ	GÉ	íÁ	€	ííÉ	FíÉ	Á	€	FEE	€	Á	€	€	€	Á
UPÖ	€€€	ÉG	É€€	ÉíH	€€€	ÉíH	É€€	Éíí	€€€	ÉíH	€€€	ÉíH	€€€	€€€	€€€	€€€

Ö[~]·ÁÚá cãÄÖ·ÁÚ}rÁI' &·
 UUÁÖ cÄFI
 Ö[~]·ÁÚá cãÄÖ·ÁÚ}rÁI' &·
 Ö[~]·ÁÚá cãÄÖ·ÁÚ}rÁI' &·

Ö[~]·ÁÚá cãÄÖ·ÁÚ}rÁI' &·
 Ö[~]·ÁÚá cãÄÖ·ÁÚ}rÁI' &·
 Ö[~]·ÁÚá cãÄÖ·ÁÚ}rÁI' &·
 Ö[~]·ÁÚá cãÄÖ·ÁÚ}rÁI' &·

Ö[~]·ÁÚá cãÄÖ·ÁÚ}rÁI' &·
 Ö[~]·ÁÚá cãÄÖ·ÁÚ}rÁI' &·
 Ö[~]·ÁÚá cãÄÖ·ÁÚ}rÁI' &·
 Ö[~]·ÁÚá cãÄÖ·ÁÚ}rÁI' &·

Ö[~]·ÁÚá cãÄÖ·ÁÚ}rÁI' &·

ÜcãÖÁã ^	Úã:ÁÚÁÖ} ^ ^ Ú[~ cã[~] } á				U&ã Ö[~]cãá Y ^·cã[~] } á Y ^·cã[~] } á				Úã:ÁÚÁÖ} ^ ^ P[~ cã[~] } á				U&ã Ö[~]cãá Y ^·cã[~] } á Öã cã[~] } á				Q cã[~] } á
	Š~c	V@~	Üã @	Ö[~] ÄV[~] cã	Š~c	V@~	Üã @	Ö[~] ÄV[~] cã	Š~c	V@~	Üã @	Ö[~] ÄV[~] cã	Š~c	V@~	Üã @	Ö[~] ÄV[~] cã	
Ä[~] KEEÖF	€	€	€	€	€	G	€	G	€	€	€	€	€	€	€	€	G
Ä[~] KÍ ÁÖF	€	€	€	€	€	F	€	F	€	€	€	€	€	€	€	€	F
Ä[~] KKEÖF	€	F	€	F	€	G	€	G	€	F	€	F	€	€	€	€	I
Ä[~] KÍ ÁÖF	€	F	F	G	€	H	€	H	€	I	€	I	€	€	€	€	J
V[~] cã	€	G	F	H	€	I	€	I	€	I	€	I	€	€	€	€	FÍ
Ä[~] KEEÖF	€	F	€	F	€	H	G	í	€	€	€	€	€	€	€	€	í
Ä[~] KÍ ÁÖF	€	F	€	F	€	í	€	í	€	€	€	€	€	€	€	€	í
Ä[~] KKEÖF	€	€	€	€	€	H	€	H	€	F	€	F	€	€	€	€	I
Ä[~] KÍ ÁÖF	€	€	F	F	€	í	€	í	€	F	€	F	€	€	€	€	F€
V[~] cã	€	G	F	H	€	G	G	GH	€	G	€	G	€	€	€	€	G
Ö[~] áÁV[~] cã	€	I	G	í	€	G	G	HF	€	í	€	í	€	€	€	€	I I
Ö[~] :&ÖÁ	€	íí È	HÈH	Á	€	JHÈ	íÈ	Á	€	F€€	€	Á	€	€	€	€	Á
V[~] cã	€	JÈÈ	IÈ	FHÈ	€	íí È	IÈ	íÈÈ	€	FíÈ	€	FíÈ	€	€	€	€	Á

ÜcãÖÁã ^	Úã:ÁÚÁÖ} ^ ^ Ú[~ cã[~] } á				U&ã Ö[~]cãá Y ^·cã[~] } á Y ^·cã[~] } á				Úã:ÁÚÁÖ} ^ ^ P[~ cã[~] } á				U&ã Ö[~]cãá Y ^·cã[~] } á Öã cã[~] } á				Q cã[~] } á
	Š~c	V@~	Üã @	Ö[~] ÄV[~] cã	Š~c	V@~	Üã @	Ö[~] ÄV[~] cã	Š~c	V@~	Üã @	Ö[~] ÄV[~] cã	Š~c	V@~	Üã @	Ö[~] ÄV[~] cã	
Üã:ÁÚÁÖ} ^ ^	€	€	€	€	€	G	€	G	€	€	€	€	€	€	€	€	G
Ä[~] KEEÖF	€	€	€	€	€	F	€	F	€	€	€	€	€	€	€	€	F
Ä[~] KÍ ÁÖF	€	1	€	F	€	G	€	G	€	F	€	F	€	€	€	€	I
Ä[~] KKEÖF	€	F	1	2	€	3	€	3	€	4	€	4	€	€	€	€	9
V[~] cã	€	G	F	H	€	í	€	í	€	í	€	í	€	€	€	€	FÍ
Ä[~] KÍ ÁÖF	€	íí È	HÈH	Á	€	F€€	€	Á	€	F€€	€	Á	€	€	€	€	Á
UPØ	€€€	È€€	È€	Èí	€€€	Èíí	€€€	Èíí	€€€	ÈFH	€€€	ÈFH	€€€	€€€	€€€	€€€	Èíí

Ô[]    Û       
 U        
 Ô[]       
 Q[]       

Ô              
              
 Ô                 
         

Ô                 
                 
                 
                 

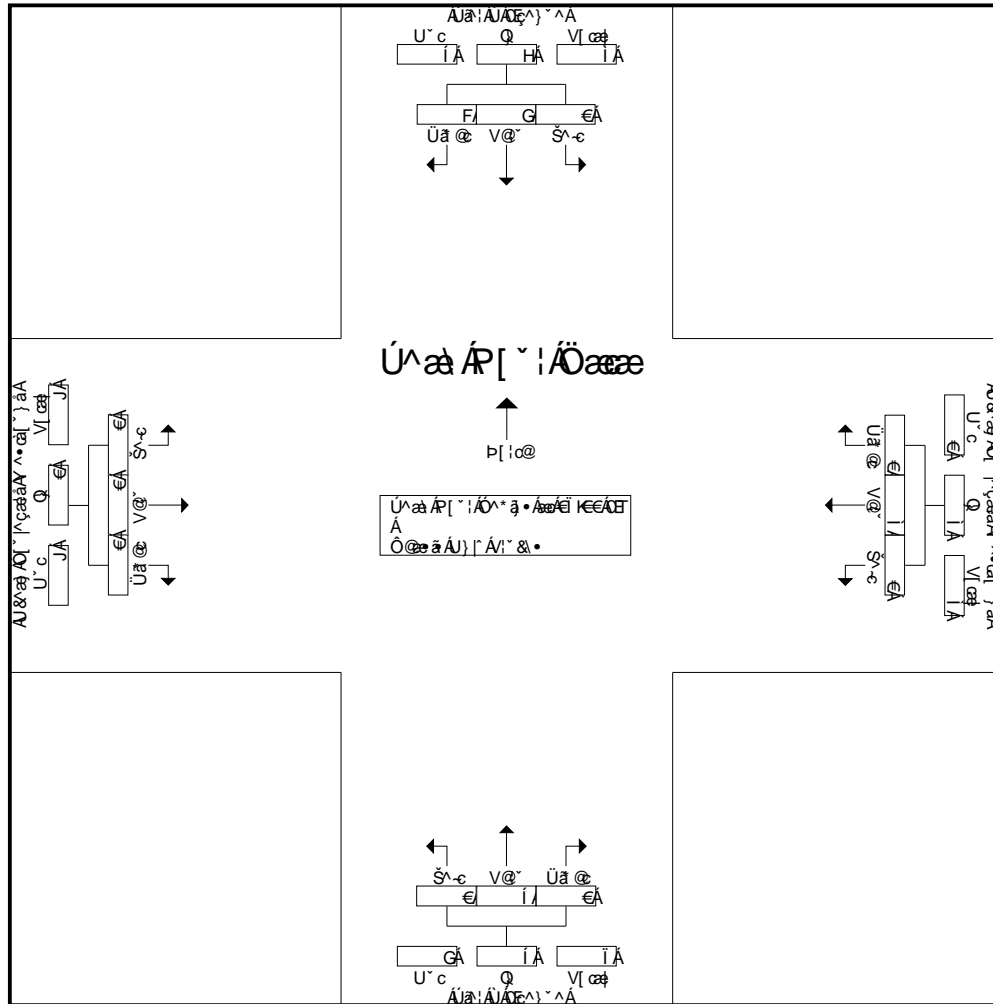

                                         
                               

	������				������				������				������			
���� ���	�	�	�	�	�	G	�	G	�	�	�	�	�	�	�	�
���� ���	�	�	�	�	�	F	�	F	�	�	�	�	�	�	�	�
���� ���	�	1	�	F	�	G	�	G	�	F	�	F	�	�	�	�
���� ���	�	F	1	2	�	3	�	3	�	4	�	4	�	�	�	�
V����� ���	�	G	F	H	�	�	�	�	�	�	�	�	�	�	�	�
���� ���	�	���	���	�	�	F��	�	�	�	F��	�	�	�	�	�	�
UP�	����	����	����	����	����	����	����	����	����	����	����	����	����	����	����	����

Ö[] • ÁV[] ä á ÁQ&É
 UUÁÖ[] cÁFI
 Ö[] () ä ÖÖÁGII
 QI FDG i È G I

Öä Á -Á[] * Á^ ä @
 ÞDUÁÜ[] ÁÜÖ[] ^ ^
 ÖY KÁÜ[] ä Ö[] ^ Ç ä á Á ^ • cä[] ä
 Y ^ ä @ : KÁÜ[] } }

ÖY Á þ ä ^ KÖÖÖÖÖÖÖÖ ÖY ÇF
 Üä ÁÖ[] ä ^ KÖÖÖÖÖÖÖF
 Ücä Öä Öä KÁÜ[] BDEFG
 Ücä ^ Á[] KÁÜ[]

Ö[] • ÁV[] ä á ÁQ&É[] ö ä ^ ÁV[] & •

Ücä Ö Á ä ^	Üä ÁÜÖ[] ^ ^ Ü[] cä[] ^ ä				U&ä Ö[] ^ Ç ä á Y ^ • cä[] ^ ä Y ^ • cä[] ^ ä				Üä ÁÜÖ[] ^ ^ P[] cä[] ^ ä				U&ä Ö[] ^ Ç ä á Y ^ • cä[] ^ ä Ö ä cä[] ^ ä				Q cä V[] ö ä	
	Š -c	V @	Ü ä @	Q[] ä V[] ö ä	Š -c	V @	Ü ä @	Q[] ä V[] ö ä	Š -c	V @	Ü ä @	Q[] ä V[] ö ä	Š -c	V @	Ü ä @	Q[] ä V[] ö ä		
È KÖÖ[]	€	F	G	H	€	FF	€	FF	€	€	€	€	€	€	€	€	€	FI
È KÍ ÁÖ[]	€	€	F	F	€	í	F	J	€	€	€	€	€	€	€	€	€	F€
È KÖÖ[]	€	€	F	F	€	í	í	FF	€	€	€	€	€	€	€	€	€	FG
È KÍ ÁÖ[]	€	F	F	G	€	FH	I	Fí	€	€	€	€	€	€	€	€	€	FJ
V[] ö ä	€	G	í	í	€	Hí	F€	Ií	€	€	€	€	€	€	€	€	€	Ií
È KÖÖ[]	€	H	G	í	€	Fí	H	Fí	€	F	€	F	€	€	€	€	€	GH
È KÍ ÁÖ[]	€	G	í	í	€	Fí	F	Fí	€	€	€	€	€	€	€	€	€	G
È KÖÖ[]	€	í	G	J	€	Fí	G	Fí	F	F	€	G	€	€	€	€	€	GJ
È KÍ ÁÖ[]	€	í	í	F€	€	G€	í	Gí	€	€	€	€	€	€	€	€	€	Hí
V[] ö ä	€	Fí	Fí	HF	€	Ií	FF	Ií	F	G	€	H	€	€	€	€	€	FFF
Ö[] ä á ÁV[] ö ä	€	FJ	FJ	Hí	€	F€	GF	FGí	F	G	€	H	€	€	€	€	€	Fí í
Q[] : & @ Á	€	í€	í€	Á	€	í H€	Fí È	Á	HÈ	íí È	€	Á	€	€	€	€	€	Á
V[] ö ä Á	€	FFÈ	FFÈ	GGÈ	€	í GÈ	F€È	íí È	ÈÈ	F€È	€	FÈ	€	€	€	€	€	Á

Ücä Ö Á ä ^	Üä ÁÜÖ[] ^ ^ Ü[] cä[] ^ ä				U&ä Ö[] ^ Ç ä á Y ^ • cä[] ^ ä Y ^ • cä[] ^ ä				Üä ÁÜÖ[] ^ ^ P[] cä[] ^ ä				U&ä Ö[] ^ Ç ä á Y ^ • cä[] ^ ä Ö ä cä[] ^ ä				Q cä V[] ö ä	
	Š -c	V @	Ü ä @	Q[] ä V[] ö ä	Š -c	V @	Ü ä @	Q[] ä V[] ö ä	Š -c	V @	Ü ä @	Q[] ä V[] ö ä	Š -c	V @	Ü ä @	Q[] ä V[] ö ä		
Üä ÁV[] ^ ÁÖ[] ä • ä Ö[] { ÁÈ KÖÖ[] ÁÈ KÍ ÁÖ[] ÁÜä ÁFÁ -F																		
È KÖÖ[]	€	1	2	3	€	FF	€	FF	€	€	€	€	€	€	€	€	€	FI
È KÍ ÁÖ[]	€	€	F	F	€	í	F	J	€	€	€	€	€	€	€	€	€	F€
È KÖÖ[]	€	€	F	F	€	í	5	FF	€	€	€	€	€	€	€	€	€	FG
È KÍ ÁÖ[]	€	F	F	G	€	13	I	17	€	€	€	€	€	€	€	€	€	19
V[] ö ä KÍ[] ^	€	G	í	í	€	Hí	F€	Ií	€	€	€	€	€	€	€	€	€	Ií
Á ÁÖ[] ä V[] ö ä	€	Gí È	í FÈ	Á	€	í J€	G€È	Á	€	€	€	Á	€	€	€	€	€	Á
UPØ	€€€	È€€	ÈG	ÈH	€€€	ÈHF	È€€	È€	€€€	€€€	€€€	€€€	€€€	€€€	€€€	€€€	€€€	ÈG

Ó[~}oAM|ãããQ&E
 UUÁQcAFIi
 Ó[!:]ããÖÖÁGii
 QI FÁG i È ð i

Óã Á -Á[]*Á^ã&@
 ÞEUIÁUã:ÁU/ÖE^}^
 ÖEY KÁU&ã ÁÖ[]^çããÁ Á•cã[~}ã
 Y^ã&@:KÁU}}}

ÖE^Áãã ^ KÖÓÓUWÓY ÖE
 Úã ÁÖ[]ã^ KEEEEEEF
 ÚããÁÖãã KÁEÞBDEFG
 Úãã^Áp[K&

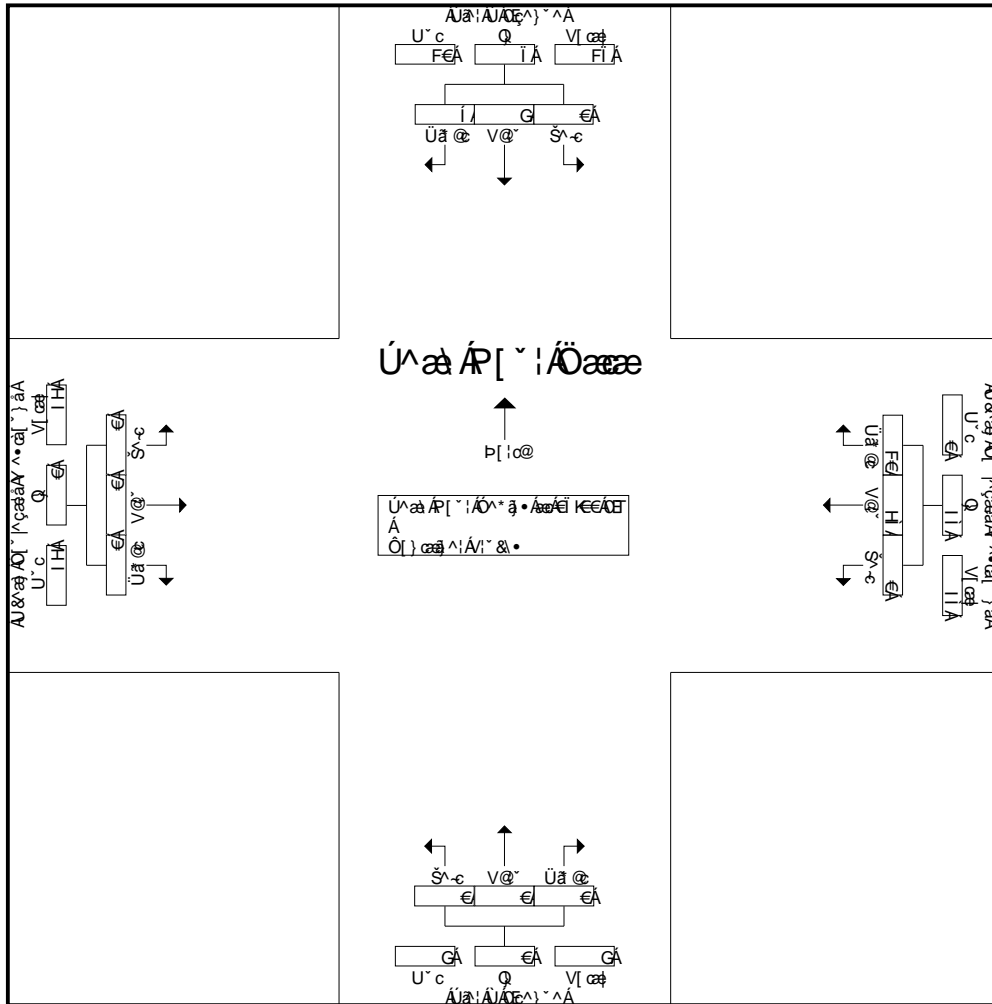

Úãã ÁP[~}!ÖÖããã ÁP[~}!ÖÖããã ÁP[~}!ÖÖããã ÁP[~}!ÖÖããã
 Úãã ÁP[~}!ÖÖããã ÁP[~}!ÖÖããã ÁP[~}!ÖÖããã ÁP[~}!ÖÖããã

	ei keeÖE				ei keeÖE				ei keeÖE				ei keeÖE			
ÉEÁ á•È	€	1	2	3	€	FF	€	FF	€	€	€	€	€	€	€	€
ÉFÁ á•È	€	€	F	F	€	i	F	J	€	€	€	€	€	€	€	€
ÉHEÁ á•È	€	€	F	F	€	i	5	FF	€	€	€	€	€	€	€	€
ÉIÁ á•È	€	F	F	G	€	13	I	17	€	€	€	€	€	€	€	€
V[çãK[]^	€	G	i	I	€	H	F€	Ii	€	€	€	€	€	€	€	€
Á ÁÖ[]EÁV[çã	€	G	È	i È	€	i J È	ÖÈ	Á	€	€	€	€	€	€	€	Á
UPÖ	ÈÈÈÈ	ÈÈÈÈ	ÈÈÈÈ	ÈÈÈÈ	ÈÈÈÈ	ÈÈÈÈ	ÈÈÈÈ	ÈÈÈÈ	ÈÈÈÈ	ÈÈÈÈ	ÈÈÈÈ	ÈÈÈÈ	ÈÈÈÈ	ÈÈÈÈ	ÈÈÈÈ	ÈÈÈÈ

Ö[~], ÖÁV|ä ä^áQ&E
 UUÁÖ|cÁFI|
 Ö[~] ä^ÖÖÁG|í
 Q|FDG|E G|í

Öä: Á -Á[~] * Á^á&@
 ÞDU|K|A:Á|U|Ö|c|Á^~
 ÖBY K|U|&|ä|Á|Ö|~|c|á|á|Á^~|ä
 Y^~@:K|U|~}}^

ÖY^Á|ä|~ ^ K|S|Ö|U|U|Ö|Y|Ö|F|
 U|ä|Á|Ö|~|ä ^ K|E|E|E|E|E|E|F|
 U|c|ä|Ö|ä|~ ^ K|H|B|D|E|F|G|
 U|ä|~|Á|~| K|F|

Ö[~] • Á|U|ä|c|ä|Ä|U|c|:Á|V|~|&•

U c ä Ö Á ~ ^ U ~ c Ö ~ } á	U ä Á U Ö c Á^~ ^ U ~ c Ö ~ } á				U ä Á U Ö c Á^~ ^ U ~ c Ö ~ } á				U ä Á U Ö c Á^~ ^ U ~ c Ö ~ } á				Q c Ä V c ä				
	Š~c	V@~	Üä@	Q Ä V c ä	Š~c	V@~	Üä@	Q Ä V c ä	Š~c	V@~	Üä@	Q Ä V c ä		Š~c	V@~	Üä@	Q Ä V c ä
€	F	€	F	€	F	H	I	€	F	€	F	€	€	€	€	€	í
€	€	€	€	€	€	I	í	€	F	€	F	€	€	€	€	€	í
€	€	€	€	€	€	G	í	€	F	€	F	€	€	€	€	€	í
€	í	G	J	€	€	í	í	€	H	€	H	€	€	€	€	€	F
V c ä	€	í	G	F€	€	I	F	GG	€	í	€	í	€	€	€	€	H
€	I	G	í	€	í	í	FH	€	€	€	€	€	€	€	€	€	FJ
€	í	G	í	€	I	I	í	€	G	€	G	€	€	€	€	€	F
€	í	€	í	€	H	í	J	€	F	€	F	€	€	€	€	€	F
€	I	G	í	€	í	í	F€	€	G	€	G	€	€	€	€	€	F
V c ä	€	G	í	G	€	F	GH	I€	€	í	€	í	€	€	€	€	íG
Ö ä á Á c ä c ä	€	G	í	H	€	G	I F	íG	€	FF	€	FF	€	€	€	€	FF€
Q Ä V c ä	€	í	€	G F	€	H	í	F	€	F€€	€	Á	€	€	€	€	Á
V c ä	€	G	í	H	€	F	H	í	€	F€	€	F€	€	€	€	€	€

U c ä Ö Á ~ ^ U ~ c Ö ~ } á	U ä Á U Ö c Á^~ ^ U ~ c Ö ~ } á				U ä Á U Ö c Á^~ ^ U ~ c Ö ~ } á				U ä Á U Ö c Á^~ ^ U ~ c Ö ~ } á				Q c Ä V c ä				
	Š~c	V@~	Üä@	Q Ä V c ä	Š~c	V@~	Üä@	Q Ä V c ä	Š~c	V@~	Üä@	Q Ä V c ä		Š~c	V@~	Üä@	Q Ä V c ä
€	F	€	F	€	F	H	I	€	F	€	F	€	€	€	€	€	í
€	€	€	€	€	€	I	í	€	F	€	F	€	€	€	€	€	í
€	€	€	€	€	€	2	í	7	€	F	€	F	€	€	€	€	í
€	7	2	9	€	€	6	í	€	3	€	3	€	€	€	€	€	18
V c ä	€	í	G	F€	€	I	F	GG	€	í	€	í	€	€	€	€	H
Á Ö c Ä V c ä	€	í	G	Á	€	F	€	í	€	F€€	€	Á	€	€	€	€	Á
UPØ	€€€	€	€	€	€€€	€€	€	€	€€€	€€	€€	€€	€€€	€€€	€€€	€€€	€€

Ó[~}oÁM|ãããã&É
 UUÁO|cÁFIÍ
 Ó[!|}ããããGÍÍ
 Q|FDG|ÈGÍ

Óã Á -Á[]*Á^ã&@
 ÞÐJKAJ:AU/CE^}^
 OEY KAJ&ã ÁO[]^çããÁ ^•cà[~}ã
 Y^ã&@:KAU"}}}

ÓE^Aã ^ KÓÓUWÓY CE
 Úã ÁO[]ã KEEEEEEF
 ÚããÁÓãã KÁBDEFG
 Úãã^Á[]K&

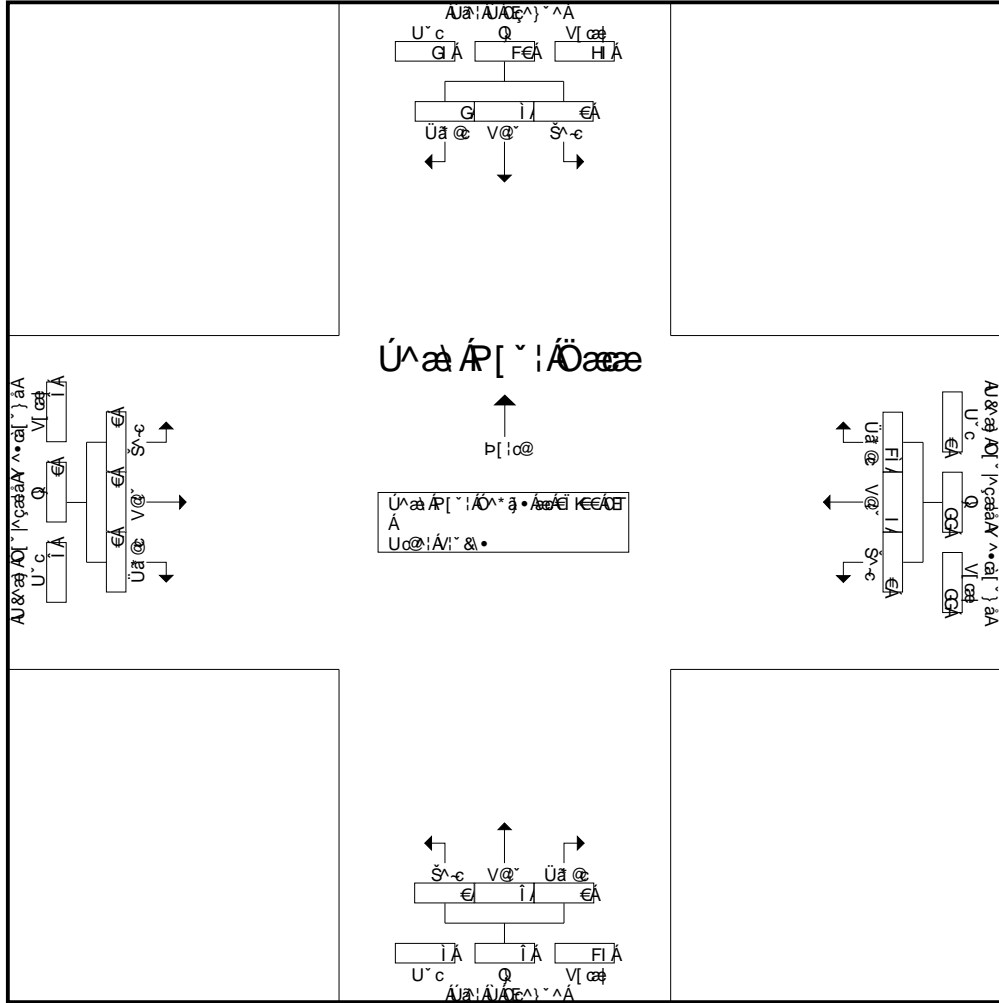

Úãã ÁR[~}!Öããæ •ã ÁO[]^çããÁ ^•cà[~}ã
 Úãã ÁR[~}!Á[]Öããæ[]!ãã@Á^ã •ããK

	eí keeÁB				eí keeÁB				eí keeÁB				eí keeÁB			
ÉeÁ á•É	€	F	€	F	€	F	H	I	€	F	€	F	€	€	€	€
ÉFÍ Á á•É	€	€	€	€	€	F	I	I	€	F	€	F	€	€	€	€
ÉHEÁ á•É	€	€	€	€	€	2	I	7	€	F	€	F	€	€	€	€
ÉIÁ á•É	€	7	2	9	€	€	6	I	€	3	€	3	€	€	€	€
VI cøK[]^	€	I	G	FE	€	I	FI	GG	€	I	€	I	€	€	€	€
Á ÁO[] ÁV[] cø	€	I	GE	Á	€	FI	È	I	€	FEE	€	Á	€	€	€	€
UPØ	€€€	€€	€€	€€	€€€	€€	€€	€€	€€€	€€	€€€	€€	€€€	€€€	€€€	€€€

Ö[]•ÁV[]á áÁQ&É
 UUÁÖ[]cÁFíí
 Ö[]()ááÖÖáGíí
 QíFDGíÉGí

Öá Á-Á[]•ÁÁá@
 ÞÞUÁUÁ:ÁUÁÖ[]•
 ÖÞY ÁUÁááÁÖ[]•
 Y^á@:ÁU[]•

ÖÁÁáá ^ ÁÖÖÖUÖY T Ö
 UÁÁÖ[]á ^ ÁÖÖÖÖÖÖF
 UááÖÁÖá ^ ÁÖÖÖÖF
 UááÁÁ[] ^ ÁÖ

Ö[]•ÁU[]á cÁáÖÖ[]á áÁV[]• &•

UááÁÁ ^	Uá:ÁUÁÖ[]• ^ U[]•cÁ[]•} á				U&áÁÖ[]• Y^•cÁ[]•} á Y^•cÁ[]•} á				Uá:ÁUÁÖ[]• ^ P[]cÁ[]•} á				U&áÁÖ[]• Y^•cÁ[]•} á Öá cÁ[]•} á				Q cÁ[]•} á		
	Š-c	V@	Üá @	Q[]ÉV[]cá	Š-c	V@	Üá @	Q[]ÉV[]cá	Š-c	V@	Üá @	Q[]ÉV[]cá	Š-c	V@	Üá @	Q[]ÉV[]cá			
€Fí€ÁÚT	€	G	H	Í	€	Í	G	Í	€	G	€	G	€	€	€	€	€	€	Fí
€Fí€ÁÚT	€	FF	í	Fí	€	FG	F	FH	€	F	€	F	€	€	€	€	€	€	HF
€Fí€ÁÚT	€	í	G	í	€	Fí	G	Fí	€	í	€	í	€	€	€	€	€	€	Gí
€Fí€ÁÚT	€	í	í	J	€	Fí	G	Fí	€	í	€	í	€	€	€	€	€	€	HF
V[]cá	€	GF	Fí	Hí	€	íí	í	íG	€	FH	€	FH	€	€	€	€	€	€	FEG
€Gí€ÁÚT	€	F€	í	Fí	€	Gí	í	H€	€	í	€	í	€	€	€	€	€	€	íF
€Gí€ÁÚT	€	Fí	í	G€	€	GH	í	Gí	€	H	€	H	€	€	€	€	€	€	íF
€Gí€ÁÚT	€	Fí	í	GH	€	Gí	G	Gí	€	í	€	í	€	€	€	€	€	€	íí
€Gí€ÁÚT	€	FJ	€	FJ	€	GH	H	Gí	€	G	€	G	€	€	€	€	€	€	íí
V[]cá	€	í€	Fí	íí	€	JJ	Fí	FFH	€	Fí	€	Fí	€	€	€	€	€	€	Gí
Ö[]ááÁ[]cá	€	íF	HH	FFí	€	Fíí	GF	Fíí	€	GJ	€	GJ	€	€	€	€	€	€	Hí
Ö[]:í&Á[]cá	€	íFí	Gí	Á	€	ííí	Fíí	Á	€	Fíí	€	Á	€	€	€	€	€	€	Á
V[]cá	€	Gí	íí	Hí	€	ííí	íí	ííí	€	Jí	€	Jí	€	€	€	€	€	€	Á

UááÁÁ ^	Uá:ÁUÁÖ[]• ^ U[]•cÁ[]•} á				U&áÁÖ[]• Y^•cÁ[]•} á Y^•cÁ[]•} á				Uá:ÁUÁÖ[]• ^ P[]cÁ[]•} á				U&áÁÖ[]• Y^•cÁ[]•} á Öá cÁ[]•} á				Q cÁ[]•} á			
	Š-c	V@	Üá @	Q[]ÉV[]cá	Š-c	V@	Üá @	Q[]ÉV[]cá	Š-c	V@	Üá @	Q[]ÉV[]cá	Š-c	V@	Üá @	Q[]ÉV[]cá				
UááÁÁ[]•:ÁÁ[]cá	€	í€	Fí	íí	€	JJ	Fí	FFH	€	Fí	€	Fí	€	€	€	€	€	€	Gí	
UááÁÁ[]•:ÁÁ[]cá	€	ííí	Gí	Á	€	ííí	Fíí	Á	€	Fíí	€	Á	€	€	€	€	€	€	Á	
UPØ	€€€	ííJ	íí	íí	€€€	ííí	íí	íí	€€€	ííí	€€€	ííí	€€€	€€€	€€€	€€€	€€€	€€€	€€€	íí

Ó[~}oÁM|ãããQ&E
 UUÁQ|cÁFíí
 Ó[!|}ããÓÁGíí
 Q|FÁGíEí

Óã Á-Á[~}^Á^ã&
 ÞEJÁUã:ÁUÁE^~^
 ÓEY KÁU&ã ÁQ[~}^çããÁ ^•cã[~}ã
 Y^ã&@:KÁU}}^

Óã Áã ^ KÓÓÓUQÓY T Ö
 Úã ÁQ[ã KEEEEEEF
 ÚããÓãã KÁE BDEFG
 Úãã Áã K&

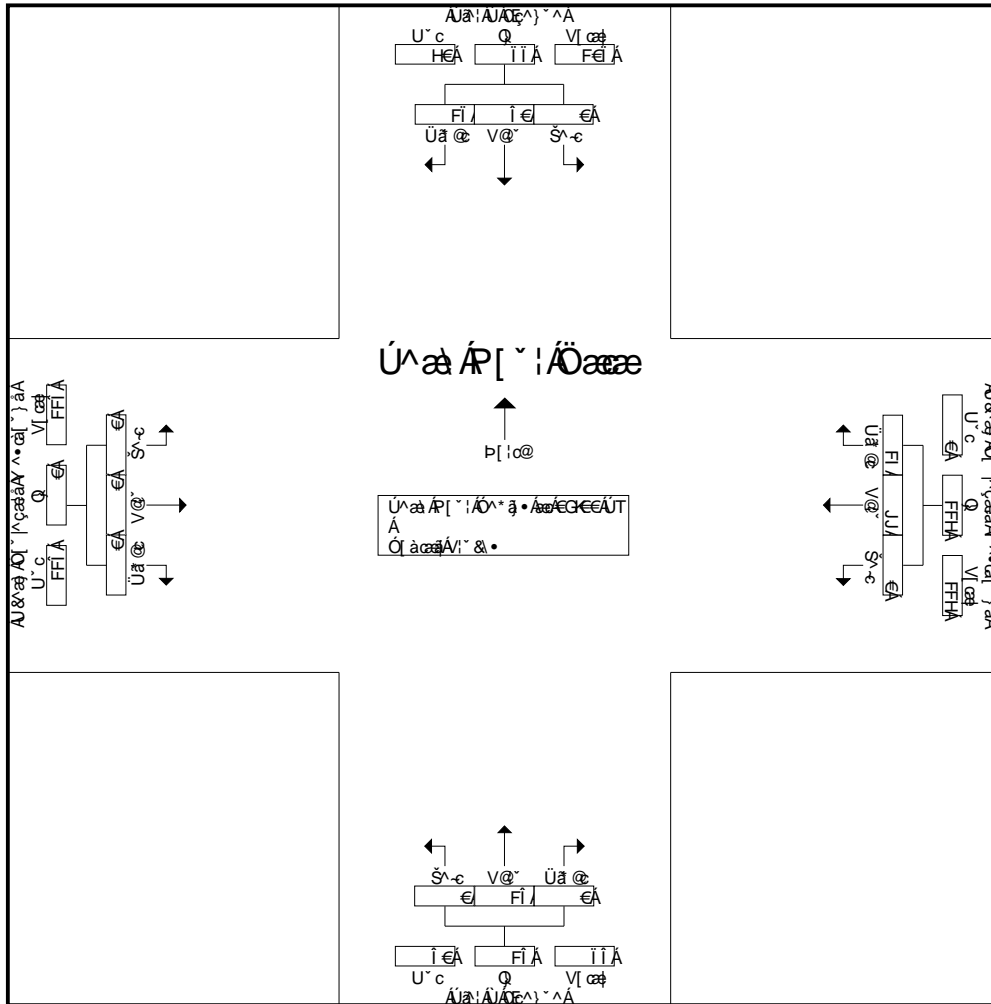

Úãã ÁR[~}!Öããæ •ã ÁQ[~} ÁEGEÁÚ ÁEGKÍ ÁÚ ÁU^ã ÁÁ-Á
 Úãã ÁR[~}!Á:Öããæ!|ããÓÁ^ã•Á&K

ÉEÁ ã•È	€	F€	í	Fí	€	G	I	30	€	6	€	6	€	€	€	€
ÉFí Á ã•È	€	Fí	6	GE	€	GH	5	Gí	€	H	€	H	€	€	€	€
ÉHEÁ ã•È	€	Fí	í	23	€	27	G	Gí	€	í	€	í	€	€	€	€
ÉÍ Á ã•È	€	19	€	FJ	€	GH	H	Gí	€	G	€	G	€	€	€	€
V cãK[~}^	€	íE	Fí	ÍÍ	€	JJ	Fí	FFH	€	Fí	€	Fí	€	€	€	€
Á ÁQ[~}V cã	€	ííE	GEF	Á	€	ííE	FGE	Á	€	FEE	€	Á	€	€	€	€
ÚPÖ	€€€	ÈíJ	ÈE	Èí	€€€	ÈFí	È€€	ÈíG	€€€	Èíí	€€€	Èíí	€€€	€€€	€€€	€€€

Ô[~], ÁÁ[ã] ááÁÙ&É
 ÚUÁÚcÁFíí
 Ô[í] ááÁÙáÙíí
 Qí FúGí ÈGí

Ôá Á-Á[~] * ÁÁ[ã]@
 ÞÁÚÁ[ã] ÁÚcÁFíí
 ÔÉY ÁÚ&á[~] ÁÚ[í] ÁÚcÁFíí * ÁÁ[ã] * á[~] * á
 Y ÁÁ[ã]@ ÁÁ[~] }

ÔÁ Á[ã] Á 1800ÚÚÚY T Ö
 Úá ÁÚ[ã] Á 18000000E
 ÚááÚá 1800000EFG
 ÚááÁ[ã] Á 18

Ô[í] ÁÁ[ã] ÁÚcÁFíí * ÁÁ[ã] @ ÁÁ[ã] ÁÚcÁFíí & ÁÁ[ã] @ ÁÁ[ã] ÁÚcÁFíí * ÁÁ[ã] @ ÁÁ[ã] ÁÚcÁFíí & ÁÁ[ã] @ ÁÁ[ã] ÁÚcÁFíí &

Úá ÁÚcÁFíí * ÁÁ[ã] @ Ú[í] ÁÚcÁFíí * á	Úá ÁÚcÁFíí * ÁÁ[ã] @ Ú[í] ÁÚcÁFíí * á	Úá ÁÚcÁFíí * ÁÁ[ã] @ Ú[í] ÁÚcÁFíí * á	Úá ÁÚcÁFíí * ÁÁ[ã] @ Ú[í] ÁÚcÁFíí * á	Úá ÁÚcÁFíí * ÁÁ[ã] @ Ú[í] ÁÚcÁFíí * á	Úá ÁÚcÁFíí * ÁÁ[ã] @ Ú[í] ÁÚcÁFíí * á	Úá ÁÚcÁFíí * ÁÁ[ã] @ Ú[í] ÁÚcÁFíí * á	Úá ÁÚcÁFíí * ÁÁ[ã] @ Ú[í] ÁÚcÁFíí * á	Úá ÁÚcÁFíí * ÁÁ[ã] @ Ú[í] ÁÚcÁFíí * á	Úá ÁÚcÁFíí * ÁÁ[ã] @ Ú[í] ÁÚcÁFíí * á	Úá ÁÚcÁFíí * ÁÁ[ã] @ Ú[í] ÁÚcÁFíí * á	Úá ÁÚcÁFíí * ÁÁ[ã] @ Ú[í] ÁÚcÁFíí * á	Úá ÁÚcÁFíí * ÁÁ[ã] @ Ú[í] ÁÚcÁFíí * á	Úá ÁÚcÁFíí * ÁÁ[ã] @ Ú[í] ÁÚcÁFíí * á	Úá ÁÚcÁFíí * ÁÁ[ã] @ Ú[í] ÁÚcÁFíí * á	Úá ÁÚcÁFíí * ÁÁ[ã] @ Ú[í] ÁÚcÁFíí * á		
ÚááÚá Á	Á-c	V@~	Úá @	Qí ÈV 000	Á-c	V@~	Úá @	Qí ÈV 000	Á-c	V@~	Úá @	Qí ÈV 000	Á-c	V@~	Úá @	Qí ÈV 000	Q 00V 000
ÈFÈÈÁÚT	€	FÍ	GE	H	€	IÍ	H	I€	€	FH	€	FH	€	€	€	€	FG
ÈFKÍ ÁÚT	€	G	FH	H	€	IÍ	FH	IÍ	€	FÍ	€	FÍ	€	€	€	€	FFJ
ÈFKÈÁÚT	€	FÍ	I	G	€	IÍ	FÍ	IÍ	€	J	€	J	€	€	€	€	FEG
ÈFKÍ ÁÚT	€	FÍ	FÍ	H	€	IÍ	G	JH	€	FÍ	€	FÍ	€	€	€	€	FÍH
V 000	€	IÍ	IÍ	FHF	€	QÍ	J	F€	€	IÍ	€	IÍ	€	€	€	€	IÍH
ÈGÈÈÁÚT	€	GF	FG	HH	€	IÍ	HF	FF€	€	FJ	€	FJ	€	€	€	€	FÍG
ÈGKÍ ÁÚT	€	GH	FÍ	H	€	IÍ	HG	F€	€	J	€	J	€	€	€	€	FÍF
ÈGKÈÁÚT	€	IÍ	FG	IÍ	€	FFG	IÍ	FÍI	€	FG	€	FH	€	€	€	€	GGE
ÈGKÍ ÁÚT	€	IÍ	I	IÍ	€	IÍ	FÍ	F€€	€	I	€	I	€	€	€	€	FÍI
V 000	€	FQ	IÍ	FÍH	€	HÍ	FGH	IÍI	€	IÍ	€	IÍ	€	€	€	€	IÍ€
Ô[í] ááÁÚ[ã] 000	€	GEE	F€	H€	€	IÍ	F	IÍI	€	F€€	€	F€F	€	€	€	€	FÍI H
Qí : & @Á	€	IÍÈ	HÍÈ	Á	€	IÍÈ	GÍÈ	Á	€	JJ	€	Á	€	€	€	€	Á
V 000	€	FÍÈ	IÍÈ	GÍÈ	€	IÍÈ	FÍÈ	IÍÈ	€	IÍÈ	€	IÍÈ	€	€	€	€	Á
ÚááÁ[ã] * ÁÁ[ã] @ ÁÁ[ã]	€	HÍ	IÍ	IÍ	€	FÍI	HÍ	G€F	€	HÍ	€	HÍ	€	€	€	€	HÍ
Á ÁÁááÁ[ã] * ÁÁ[ã] @ ÁÁ[ã]	€	FÍÈ	HÍÈ	GÍÈ	€	GÍÈ	FÍÈ	GÍÈ	€	HÍ	€	HÍÈ	€	€	€	€	GÍÈ
Ô[í] ááÁÚ[ã] * ÁÁ[ã] @ ÁÁ[ã]	€	IÍ	HÍ	FÍI	€	FÍI	GÍ	FÍI	€	GÍ	€	GÍ	€	€	€	€	HÍ
Á ÁÁááÁ[ã] * ÁÁ[ã] @ ÁÁ[ã]	€	IÍÈ	HÍÈ	HÍÈ	€	GÍÈ	JÍÈ	GÍÈ	€	GÍ	€	GÍÈ	€	€	€	€	GÍ
ÔááÁÚ[ã] * ÁÁ[ã] @ ÁÁ[ã]	€	F€	F	FF	€	I€	IÍ	FFJ	€	FF	€	FF	€	€	€	€	FÍF
Á ÁÁááÁ[ã] * ÁÁ[ã] @ ÁÁ[ã]	€	I	F	H€	€	IÈ	HÍÈ	FÍÈ	€	FF	€	F€È	€	€	€	€	FFÈ
Ô[í] ááÁÚ[ã] * ÁÁ[ã] @ ÁÁ[ã]	€	H€	FÍ	IÍ	€	FÍI	GÍ	GÍ	€	FÍ	€	FÍ	€	€	€	€	GÍ
Á ÁÁááÁ[ã] * ÁÁ[ã] @ ÁÁ[ã]	€	FÍ	FÍÈ	FÍÈ	€	HÍÈ	FQÈ	GÍÈ	€	F€€	FÍ	FÍÈ	€	€	€	€	GÍÈ
ÚááÁÚ[ã] * ÁÁ[ã] @ ÁÁ[ã]	€	IÍ	FH	IÍ	€	GÍ	IÍ	IÍ	€	J	€	J	€	€	€	€	FÍG
Á ÁÁááÁ[ã] * ÁÁ[ã] @ ÁÁ[ã]	€	GF	FQÈ	FÍÈ	€	IÈ	GÍÈ	F€	€	J	€	IÈ	€	€	€	€	FG

Úá ÁÚcÁFíí * ÁÁ[ã] @ Ú[í] ÁÚcÁFíí * á	Úá ÁÚcÁFíí * ÁÁ[ã] @ Ú[í] ÁÚcÁFíí * á	Úá ÁÚcÁFíí * ÁÁ[ã] @ Ú[í] ÁÚcÁFíí * á	Úá ÁÚcÁFíí * ÁÁ[ã] @ Ú[í] ÁÚcÁFíí * á	Úá ÁÚcÁFíí * ÁÁ[ã] @ Ú[í] ÁÚcÁFíí * á	Úá ÁÚcÁFíí * ÁÁ[ã] @ Ú[í] ÁÚcÁFíí * á	Úá ÁÚcÁFíí * ÁÁ[ã] @ Ú[í] ÁÚcÁFíí * á	Úá ÁÚcÁFíí * ÁÁ[ã] @ Ú[í] ÁÚcÁFíí * á	Úá ÁÚcÁFíí * ÁÁ[ã] @ Ú[í] ÁÚcÁFíí * á	Úá ÁÚcÁFíí * ÁÁ[ã] @ Ú[í] ÁÚcÁFíí * á	Úá ÁÚcÁFíí * ÁÁ[ã] @ Ú[í] ÁÚcÁFíí * á	Úá ÁÚcÁFíí * ÁÁ[ã] @ Ú[í] ÁÚcÁFíí * á	Úá ÁÚcÁFíí * ÁÁ[ã] @ Ú[í] ÁÚcÁFíí * á	Úá ÁÚcÁFíí * ÁÁ[ã] @ Ú[í] ÁÚcÁFíí * á	Úá ÁÚcÁFíí * ÁÁ[ã] @ Ú[í] ÁÚcÁFíí * á	Úá ÁÚcÁFíí * ÁÁ[ã] @ Ú[í] ÁÚcÁFíí * á		
ÚááÚá Á	Á-c	V@~	Úá @	Qí ÈV 000	Á-c	V@~	Úá @	Qí ÈV 000	Á-c	V@~	Úá @	Qí ÈV 000	Á-c	V@~	Úá @	Qí ÈV 000	Q 00V 000
ÈGÈÈÁÚT	€	GF	FG	HH	€	IÍ	HF	FF€	€	19	€	19	€	€	€	€	FÍG
ÈGKÍ ÁÚT	€	GH	15	H	€	IÍ	HG	F€	€	J	€	J	€	€	€	€	FÍF
ÈGKÈÁÚT	€	IÍ	FG	53	€	112	42	154	€	1	FG	€	FH	€	€	€	220
ÈGKÍ ÁÚT	€	42	I	IÍ	€	IÍ	FÍ	F€€	€	I	€	I	€	€	€	€	FÍI
V 000	€	FQ	IÍ	FÍH	€	HÍ	FGH	IÍI	€	F	IÍ	€	IÍ	€	€	€	IÍ€
Á ÁÁááÁ[ã] * ÁÁ[ã] @ ÁÁ[ã]	€	IÍÈ	GÍÈ	Á	€	IÍÈ	GÍÈ	Á	€	G	JÍ	€	Á	€	€	€	Á
UPØ	ÈÈÈ	ÈIÍ	ÈIÍ	ÈFÍ	ÈÈÈ	ÈI€	ÈHG	ÈI€	ÈÈ€	ÈHG	ÈÈÈ	ÈIÍ	ÈÈÈ	ÈÈÈ	ÈÈÈ	ÈÈÈ	ÈIÍ

Ó[~}•ÁM|ãããQ&E
 UUÁQ|cAFfI
 Ó[!|}ããÖÖÁGíi
 Q|FÁGíEí

Óã Á -Á[]*Á^ã&@
 ÞEJKAJã:ÁUÁE^~^
 ÖEY KAÜ&ã ÁQ[]^çããÁ Á•cã[~}ã
 Y^ã&@:KAÜ"}}}

ÖÁ^ãã ^ KÖÓÓUWÓY T Ö
 ÚãÁQ[ã^ KEEEEEEF
 ÚcãÖÖã^ KAÞBDFG
 Úã^Á[K&

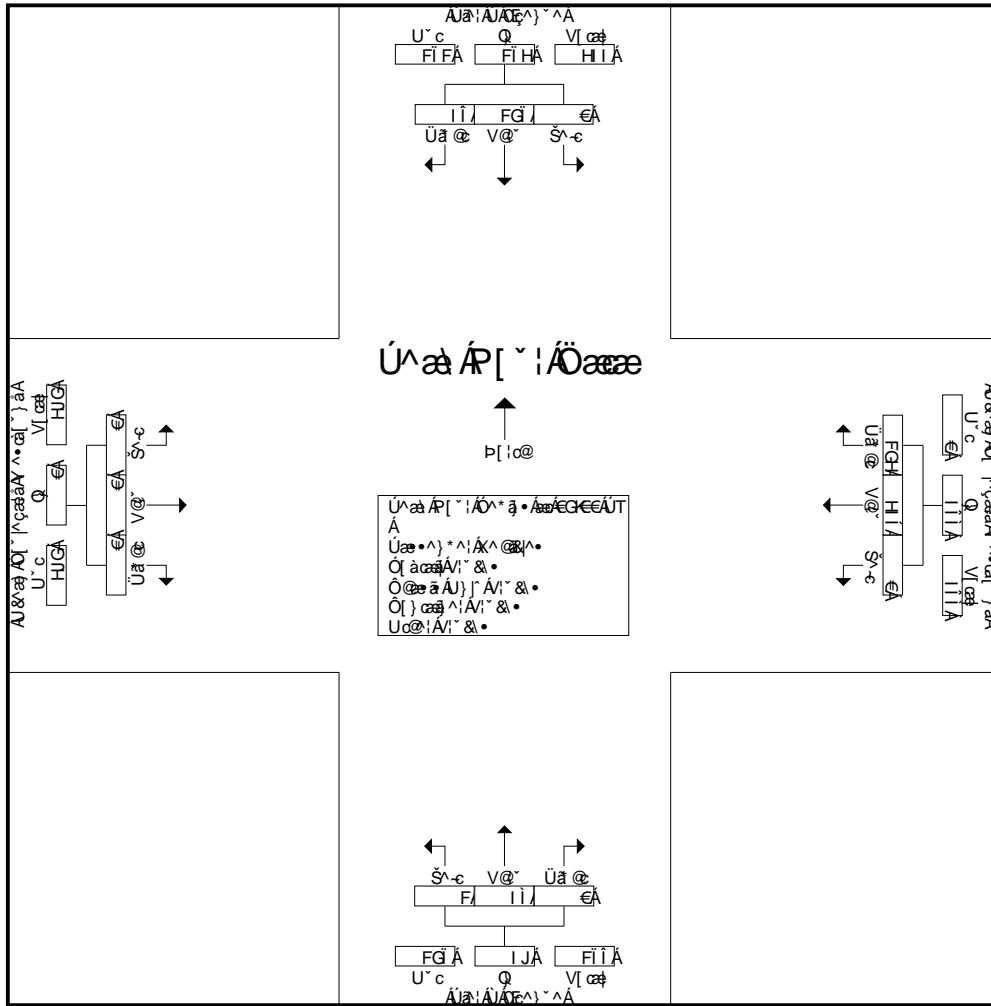

Úã ÁP[~}!ÖÖãã Á•cããEÉÉÁÚT ÁEKGÍÁÚT ÁU^ããÁÁ-Á
 Úã ÁP[~}!ÁV|ÖÖÁQ[]!ããÖÖÁ^ã•ÁãK

	EÉÉÉÚT				EÉÉÉÚT				EFGÍÁÚT				EFGÉÁÚT			
ÉÉÁ á•É	€	GF	FG	HH	€	IJ	HF	FFÉ	€	FI	€	FI	€	€	€	€
ÉFÍ Á á•É	€	GH	15	H	€	I G	HG	FÉI	€	J	€	J	€	€	€	€
ÉHÉ Á á•É	€	IF	FG	53	€	112	42	154	€	Fí	€	Fí	€	€	€	€
ÉIÍ Á á•É	€	42	i	IJ	€	I G	Fí	FÉÉ	€	19	€	19	€	€	€	€
V cãK[]^ ^	€	FQ	IÍ	FíH	€	Hí	FQH	IÍI	€	Ií	€	Ií	€	€	€	€
Á ÁQ[]EÁV cã	€	IÍE	GÍE	Á	€	IÍE	GÍE	Á	€	FEE	€	Á	€	€	€	€
UPÖ	EÉÉÉ	EÉÍ	EÉII	EÉFí	EÉÉÉ	EÉI€	EÉHG	EÉI€	EÉÉÉ	EÉIH	EÉÉÉ	EÉIH	EÉÉÉ	EÉÉÉ	EÉÉÉ	EÉÉÉ

Ö[~]•ÁV|ä ä•áQ&É
 UUÁÖ|çÁFÍ
 Ö[~]•áÖÖÁGÍ
 Q|FÖG|ÉG|

Öä Á-Ä[~]•ÁÖä@
 ÞÖU|Ä|Á|Ö|Ä|~^
 ÖY|Ä|&|Ä|~|ç|ä|Á|~|ä
 Y^ä@:|Ä|~}}

Ö|Ä|ä|~^|KÖÖÖÖÖÖÖÖÖ T Ö
 Ü|Ä|Ä|~^|KÖÖÖÖÖÖÖÖÖ
 Ü|ä|Ö|Ä|~^|KÖÖÖÖÖÖÖÖÖ
 Ü|ä|Ä|~^|KÖÖÖÖÖÖÖÖÖ

Ö[~]•ÁV|ä ä•áQ&É*^|Ä|~^

Ü ä Ä ~^ Ü ~ ç Ä ~ ä	Ü Ä Ä ~^ Ü ~ ç Ä ~ ä				U& Ä ~ ç ä Y^• ç ~ ä Y^• ç ~ ä				Ü Ä Ä ~^ P ç Ä ~ ä				U& Ä ~ ç ä Y^• ç ~ ä Ö ä ~ ä				Q Ä ~
	Š^c	V@~	Ü ä ~	Q Ä ~	Š^c	V@~	Ü ä ~	Q Ä ~	Š^c	V@~	Ü ä ~	Q Ä ~	Š^c	V@~	Ü ä ~	Q Ä ~	
€F € Ä ~	€	I	F€	F	€	G	I	H	€	J	€	J	€	€	€	€	I
€F € Ä ~	€	F	I	I	€	F	I	G€	€	I	€	I	€	€	€	€	H
€F € Ä ~	€	I	H	I	€	F	G	F	€	H	€	H	€	€	€	€	G
€F € Ä ~	€	H	I	F€	€	FH	I	G€	€	I	€	I	€	€	€	€	H
V ç Ä ~	€	FG	G	H	€	I F	G€	JF	€	GH	€	GH	€	€	€	€	F F
€G € Ä ~	€	I	H	F€	€	G	G	G	€	I	€	I	€	€	€	€	I F
€G € Ä ~	€	F	I	I	€	F	I	GG	€	I	€	I	€	€	€	€	H G
€G € Ä ~	€	I	H	FF	€	HG	F€	I G	€	F	€	F	€	€	€	€	I I
€G € Ä ~	€	J	I	F	€	FJ	F	G€	€	I	€	I	€	€	€	€	H
V ç Ä ~	€	G	F	I F	€	JH	F	FF€	€	F	€	F	€	€	€	€	F I
Ö ä ä Ä ~	€	H	I F	I I	€	F I	H	G€F	€	H	€	H	€	€	€	€	H F
Q Ä ~ & Ä ~	€	I I	I ç	Ä	€	I F	F I	Ä	€	F€€	€	Ä	€	€	€	€	Ä
V ç Ä ~	€	FF	FH	G I	€	I F	FF	I H	€	FF	€	FF	€	€	€	€	Ä

Ü ä Ä ~^	Ü Ä Ä ~^ Ü ~ ç Ä ~ ä				U& Ä ~ ç ä Y^• ç ~ ä Y^• ç ~ ä				Ü Ä Ä ~^ P ç Ä ~ ä				U& Ä ~ ç ä Y^• ç ~ ä Ö ä ~ ä				Q Ä ~
	Š^c	V@~	Ü ä ~	Q Ä ~	Š^c	V@~	Ü ä ~	Q Ä ~	Š^c	V@~	Ü ä ~	Q Ä ~	Š^c	V@~	Ü ä ~	Q Ä ~	
U ä Ä ~	€	I	H	F€	€	G	G	G	€	5	€	5	€	€	€	€	I F
U ä Ä ~	€	F	5	I	€	F	I	GG	€	I	€	I	€	€	€	€	H G
U ä Ä ~	€	I	H	FF	€	32	10	42	€	F	€	F	€	€	€	€	54
U ä Ä ~	€	9	I	14	€	FJ	F	G€	€	I	€	I	€	€	€	€	H
V ç Ä ~	€	G	F	I F	€	JH	F	FF€	€	F	€	F	€	€	€	€	F I
Ä Ä ~	€	I F	HJ	Ä	€	I I	F I	Ä	€	F€€	€	Ä	€	€	€	€	Ä
UPØ	€€€	€€	€€	€€	€€€	€€	€€	€€	€€	€€	€€	€€	€€€	€€€	€€€	€€€	€€

Ó[~},oÁM|ã,ãããQ&E
 UUÁQ|cÁFíí
 Ó[!:]ããÖÖÁGíí
 QíFÁGííEíGí

Óã Á -Á[] * Á^ã&@
 ÞEUIÁUã:ÁU/ÖE^ } ^
 ÖEY KÁU&ã ÁQ[] ^çããÁ ^•cã[~} á
 Y ^ã&@:KÁU } }

ÖÁ^Áãã ^ KÖÖÖUÖY T Ö
 Úã^ÁQ[á^ KÖÖÖÖÖÖF
 Úãã^Öãã^ KÁBDEFG
 Úãã^Á[KÖ

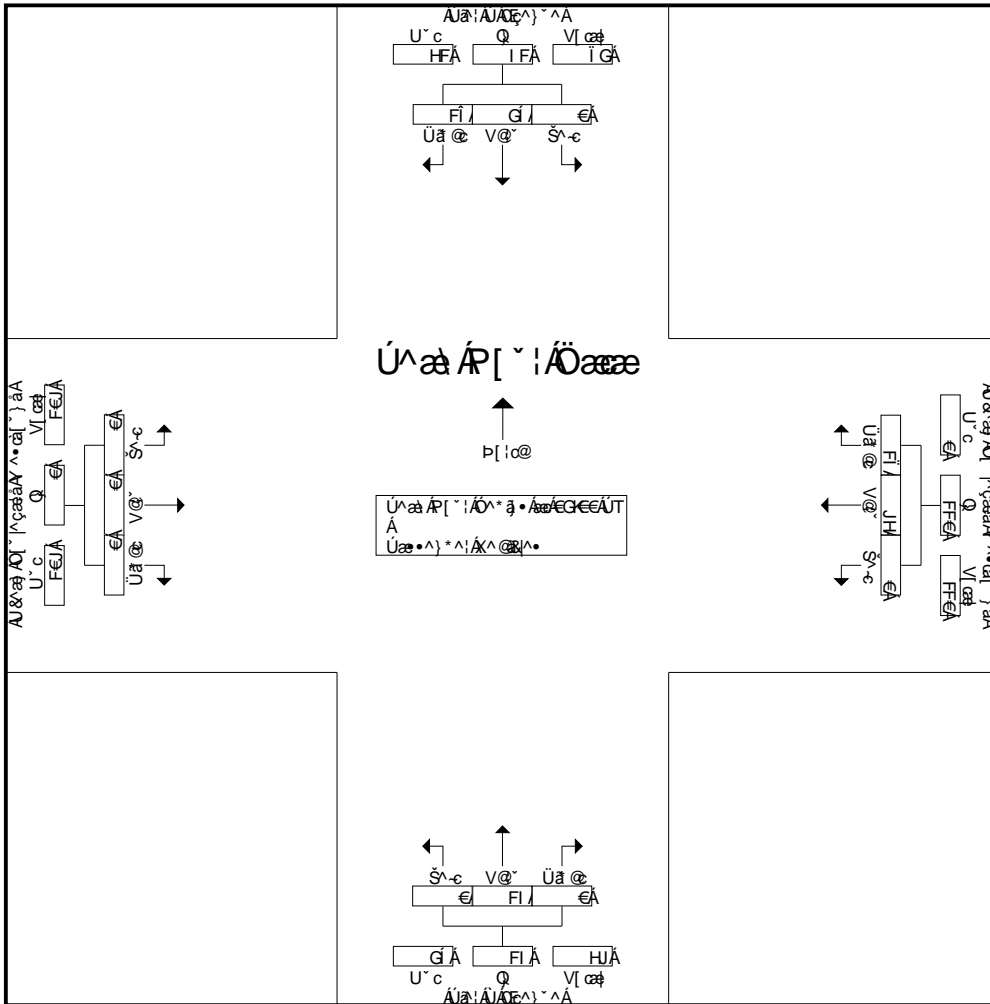

Úãã ÁR[~]!Ö^ã•Á ÁQ[] { EGEÁÚT Á EGI ÁÚT ÁU^ãã ÁÁ -Á
 Úãã ÁR[~]!Á! Öãã ÖQ[]!|ãã Ö^ã•Á ÁK

	EGEÁÚT				EGEÁÚT				EGEÁÚT				EGEÁÚT			
ÉEÁ á•É	€	í	H	F€	€	G	G	G	€	5	€	5	€	€	€	€
ÉFÍ Á á•É	€	F	5	í	€	Fí	I	Gí	€	I	€	I	€	€	€	€
ÉHEÁ á•É	€	í	H	FF	€	32	10	42	€	F	€	F	€	€	€	€
ÉIÁ á•É	€	9	í	14	€	FJ	F	G€	€	I	€	I	€	€	€	€
V öãK[] ^	€	G	Fí	I F	€	JH	Fí	FF€	€	Fí	€	Fí	€	€	€	€
Á ÁQ[] EÁV öã	€	íF	HU	Á	€	ííE	FíE	Á	€	F€€	€	Á	€	€	€	€
UPÖ	€€€	€€	€€	€€	€€€	€€	€€	€€	€€€	€€	€€€	€€	€€€	€€€	€€€	€€€

Ó[~ } . Á M | á . á á Á & É
 UUÁ Q c Á F I I
 Ó[| |] á á Ö Ö Á G I I
 Q I F Á G I É G I

Ó á Á - Á | } * Á ^ á @
 Þ Ð J K Á : Á / Ö ^ } ^
 Ö Þ Y K Á & á Á | ^ ç á á Á ^ * á [~ } á
 Y ^ á @ : K Á } } ^

Ö Þ Á á ^ K Ö Ö U Ö Y T Ö
 Ú á Á Ö | á ^ K E E E E E F
 Ú á á Ö á ^ K Á Ð B E F G
 Ú á ^ Á | K G

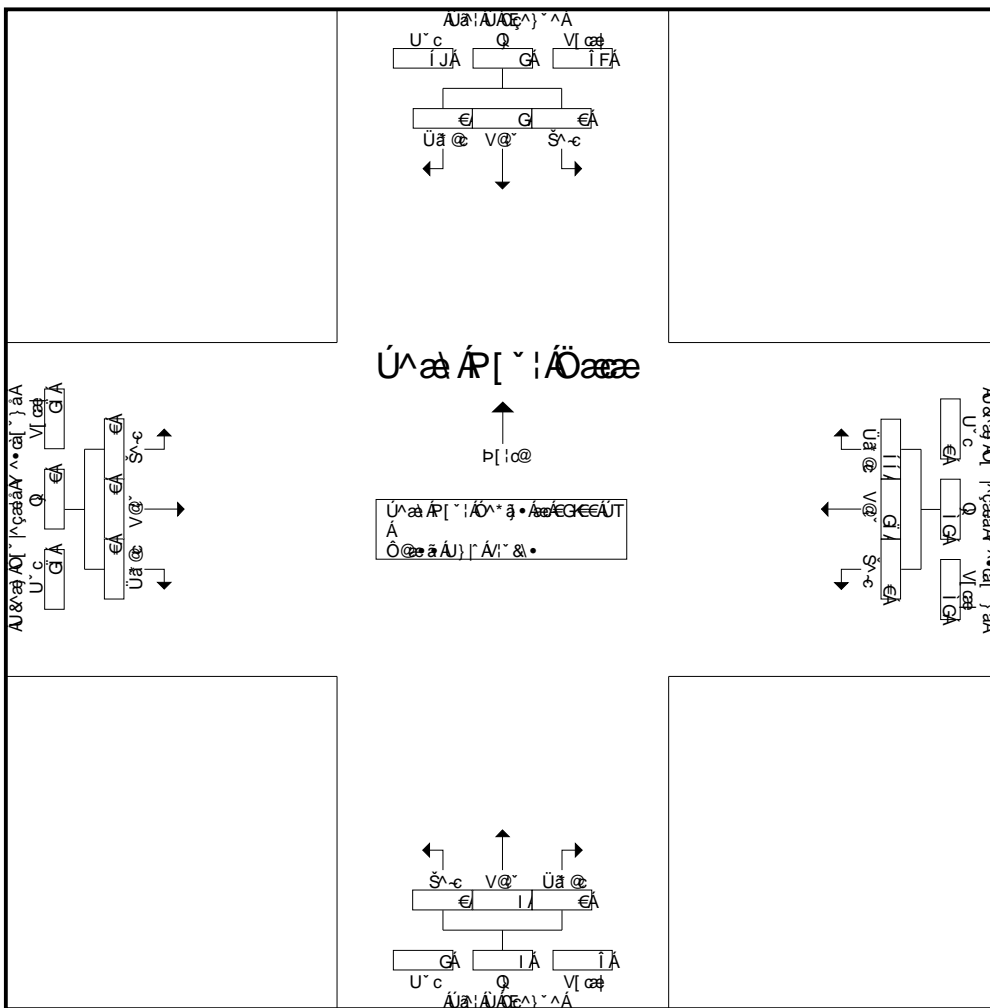

Ú á á Á R [~ | Ö á á * Á Á | { Á E G E E Á T Á Á E G K I Á T Á Á Ú á á Á Á - Á
 Ú á á Á R [~ | Á | Ö á á Ö | | | á @ Á * á * Á á K

	EGEÁÚT				EGEÁÚT				EGEÁÚT				EGEÁÚT				
É É Á á . É	€	€	€	€	€	í	20	27	€	2	€	€	2	€	€	€	€
É F I Á á . É	€	1	€	1	€	í	FÉ	Fí	€	€	€	€	€	€	€	€	€
É H E Á á . É	€	€	€	€	€	8	Fí	Gí	€	F	€	€	F	€	€	€	€
É I I Á á . É	€	F	€	F	€	í	Fí	FH	€	F	€	€	F	€	€	€	€
V I ç á K ^	€	G	€	G	€	Gí	íí	íG	€	I	€	€	I	€	€	€	€
Á Á Ö Á V I ç á	€	FEE	€	Á	€	HGE	ííÉ	Á	€	FEE	€	€	Á	€	€	€	€
U P Ö	€€€	É €	€€€	É €	€€€	É	É	É J	€€€	É €	€€€	É €	€€€	€€€	€€€	€€€	

Ö[]·ÁM|ã á·áQ&É
 UUÁÖ|çÁFÍ|
 Ö[]·á·ÖÖÁGÍ|
 Q|FDG|ÈG|

Öä Á·Á[]·Á·á·á·
 Þ·H|Á·Á·Á·Á·Á·Á·
 Ö·Y·K|Á·Á·Á·Á·Á·Á·
 Y·Á·á·á·Á·Á·Á·

Ö·Y·Á·Á·Á·
 Ú·á·Á·Á·Á·
 Ú·á·á·á·á·
 Ú·á·Á·Á·

Ö[]·Á·Á·Á·Á·Á·Á·Á·

Ú·á·á·á· Ú[]·Á·Á·Á·	Ú·á·Á·Á· Ú[]·Á·Á·Á·				U&á·Á·Á· Y·Á·Á·Á· Y·Á·Á·Á·				Ú·á·Á·Á· P[]·Á·Á·Á·				U&á·Á·Á· Y·Á·Á·Á· Ö·á·Á·Á·				Q·á·Á·Á·
	Š·c	V@	Ü·á·@	Q ·ÈV ·ç	Š·c	V@	Ü·á·@	Q ·ÈV ·ç	Š·c	V@	Ü·á·@	Q ·ÈV ·ç	Š·c	V@	Ü·á·@	Q ·ÈV ·ç	
€FKEÁÚT	€	F	I	Í	€	J	I	FÍ	€	F	€	F	€	€	€	€	GG
€FKÍÁÚT	€	I	F	Í	€	GE	H	GH	€	F	€	F	€	€	€	€	HE
€FKHÁÚT	€	H	H	Í	€	FH	I	FÍ	€	€	€	€	€	€	€	€	GH
€FKÍÁÚT	€	I	G	Í	€	GJ	G	HF	€	I	€	I	€	€	€	€	IF
V[]·ç	€	FH	FÈ	GH	€	ÍF	FÍ	ÍÍ	€	Í	€	Í	€	€	€	€	FFÍ
€GKEÁÚT	€	F	G	H	€	GF	€	GF	€	I	€	I	€	€	€	€	GJ
€GKÍÁÚT	€	H	F	I	€	GH	Í	GJ	€	€	€	€	€	€	€	€	HH
€GKHÁÚT	€	I	H	FF	€	IF	I	ÍÍ	F	G	€	H	€	€	€	€	IJ
€GKÍÁÚT	€	I	€	Í	€	HG	F	HH	€	F	€	F	€	€	€	€	HJ
V[]·ç	€	FÍ	Í	GH	€	FFÍ	FF	FG	F	I	€	J	€	€	€	€	FÍ€
Ö[]·á·Á·Á· Q ·ÈV ·ç	€	HE	FÍ	ÍÍ	€	FÍ	G	GÍ	F	FÍ	€	FÍ	€	€	€	€	GÍ
V[]·ç	€	FÈÈ	HÈ	Á	€	ÍÍÈ	FÈÈ	Á	ÍÈ	JHÈ	€	Á	€	€	€	€	Á
V[]·ç	€	FÈÈ	ÍÈ	FÍÈ	€	ÍÍÈ	JÈÈ	ÍÍÈ	ÈÈ	ÍÈÈ	€	ÍÈÈ	€	€	€	€	Á

Ú·á·á·á· Ú[]·Á·Á·Á·	Ú·á·Á·Á· Ú[]·Á·Á·Á·				U&á·Á·Á· Y·Á·Á·Á· Y·Á·Á·Á·				Ú·á·Á·Á· P[]·Á·Á·Á·				U&á·Á·Á· Y·Á·Á·Á· Ö·á·Á·Á·				Q·á·Á·Á·
	Š·c	V@	Ü·á·@	Q ·ÈV ·ç	Š·c	V@	Ü·á·@	Q ·ÈV ·ç	Š·c	V@	Ü·á·@	Q ·ÈV ·ç	Š·c	V@	Ü·á·@	Q ·ÈV ·ç	
U·á·Á·Á· U·á·Á·Á· U·á·Á·Á·	€	F	G	H	€	GF	€	GF	€	5	€	5	€	€	€	€	GJ
U·á·Á·Á· U·á·Á·Á· U·á·Á·Á·	€	H	F	I	€	GH	6	GJ	€	€	€	€	€	€	€	€	HH
U·á·Á·Á· U·á·Á·Á· U·á·Á·Á·	€	8	3	11	€	41	I	45	€	G	€	H	€	€	€	€	59
U·á·Á·Á· U·á·Á·Á· U·á·Á·Á·	€	I	€	Í	€	HG	F	HH	€	F	€	F	€	€	€	€	HJ
V[]·ç	€	FÍ	Í	GH	€	FFÍ	FF	FG	F	I	€	J	€	€	€	€	FÍ€
U·á·Á·Á· U·á·Á·Á· U·á·Á·Á·	€	ÍÈÈ	GÈÈ	Á	€	JFÈÈ	ÍÈÈ	Á	FFÈÈ	ÍÍÈÈ	€	Á	€	€	€	€	Á
U·á·Á·Á· U·á·Á·Á· U·á·Á·Á·	€	ÈÈÈ	ÈÈÈ	ÈÈÈ	€	ÈÈÈ	ÈÈÈ	ÈÈÈ	ÈÈÈ	ÈÈÈ	€	ÈÈÈ	€	€	€	€	ÈÈÈ

Ó[~ } . ÁM |ãã Á Q&É
 UUÁO] cÁFFII
 Ó[!:]ããÖÖÁG II
 QI FÓG I È G I

Óã Á -Á[] * ÁOã&@
 ÐBUÁUã:ÁUÁE^ ^ ^
 ÖEY KÁU&ã ÁO[^ çããÁ Á•cà[~ } á
 Y ^ã@:KÁU } }

Óã Áã ^ KÖÓÓUWÓY T Ö
 Úã ÁO[áã KÉÉÉÉÉÉÉF
 ÚããOÁãã KÁEDEFG
 ÚããÁ[ã K&

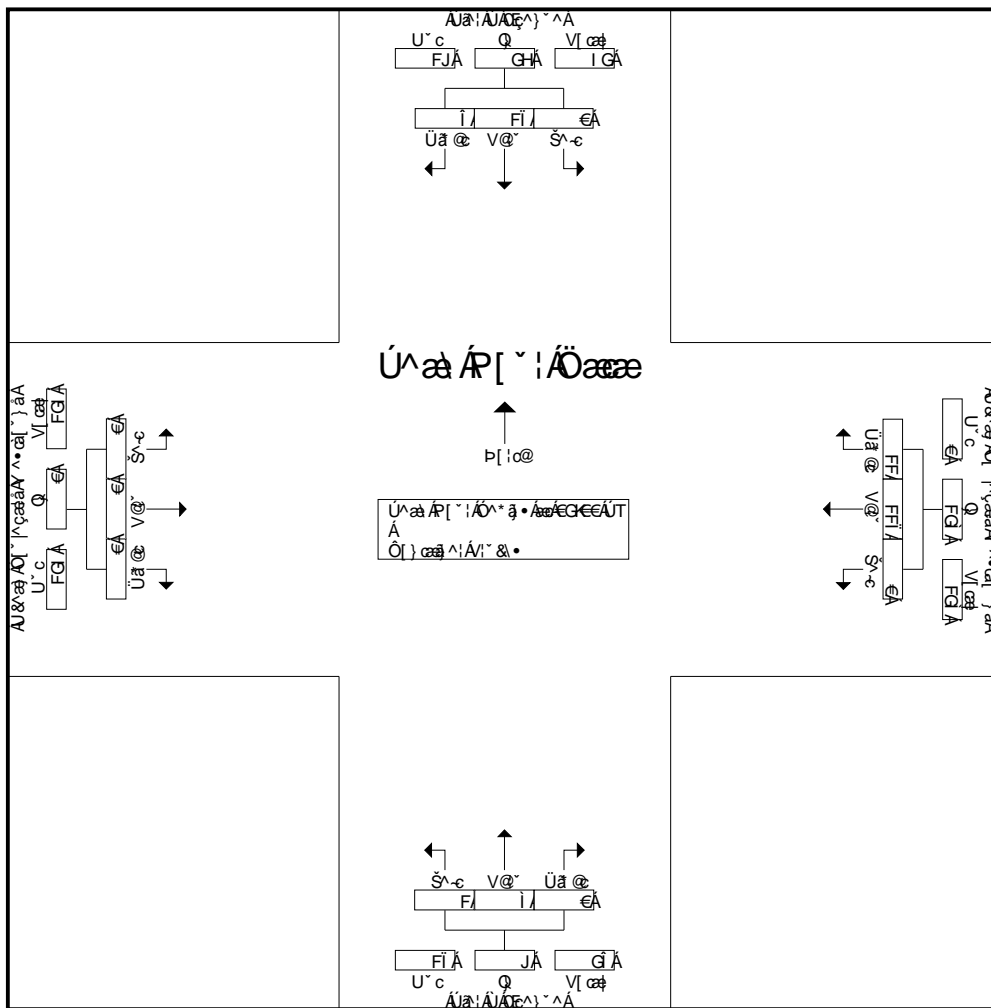

Úãã ÁR[~ ! ÖÖãã : Áã ÁO[] Áã ÁGÉÉÁÚ Á Áã K I ÁÚ Á Á Úãã Á Á Á
 Úãã ÁR[~ ! Á! ÖÖãã ÖÖ!]!ããÖÖÁã Áã ÁK

	ēēēēÚT				ēēēēÚT				ēēēēÚT				ēēēēÚT			
ÉéÁ á•È	€	F	G	H	€	GF	€	Gf	€	5	€	5	€	€	€	€
ÉfÍ Á á•È	€	H	F	I	€	GH	6	Gf	€	€	€	€	€	€	€	€
ÉhÉ Á á•È	€	8	3	11	€	41	I	45	1	G	€	H	€	€	€	€
ÉíÍ Á á•È	€	í	€	í	€	HG	F	HH	€	F	€	F	€	€	€	€
V cãK[] { ^	€	Fí	í	GH	€	FFí	FF	FG	F	í	€	J	€	€	€	€
Á ÁOH] ÁV cã	€	í HÉ	G íÉ	Á	€	JFíÉ	í É	Á	FFíÉ	í íÉ	€	Á	€	€	€	Á
ÚÐÓ	ÈÈÈÈ	ÈÈFH	ÈÈÈÈ	ÈÈGH	ÈÈÈÈ	ÈÈFH	ÈÈíí	ÈÈFF	ÈÈ€€	ÈÈÈÈ	ÈÈí€	ÈÈÈÈ	ÈÈÈÈ	ÈÈÈÈ	ÈÈÈÈ	ÈÈÈÈ

Ö[~]•ÁV|ããáÁ&É
 UUÁÖçÁFÍI
 Ö[~]•áÁÖçÁGíi
 QI FDI È G I

Öá Á-Á[~]•ÁÖã@
 ÞDUÁUÁ:ÁUÖç^~^
 ÖEY KÁU&áÁÖ[~]çãáÁ^•cá[~]á
 Y^ã@:KÁ[~]}}

Öá Á-Á[~]•ÁÖã@ KÖÖÓUWÓY T Ö
 ÞDUÁUÁ:ÁUÖç^~^ KÖÖÖÖÖÖF
 ÖEY KÁU&áÁÖ[~]çãáÁ^•cá[~]á KÁU&áÁÖ[~]çãáÁ^•cá[~]á
 Y^ã@:KÁ[~]}} KÁU&áÁÖ[~]çãáÁ^•cá[~]á

Ö[~]•ÁUãçáÁUöçÁÁI^&•

ÜçãÁã ^	Úá:ÁUÖç^~^ Ú[~]cá[~]á				U&áÁÖ[~]çãá Y^•cá[~]á Y^•cá[~]á				Úá:ÁUÖç^~^ P[~]cá[~]á				U&áÁÖ[~]çãá Y^•cá[~]á Öçcá[~]á				QçÁV[~]çã
	Š~c	V@~	Üã@	Qç ÈV[~]çã	Š~c	V@~	Üã@	Qç ÈV[~]çã	Š~c	V@~	Üã@	Qç ÈV[~]çã	Š~c	V@~	Üã@	Qç ÈV[~]çã	
€FKEÁÜT	€	í	G	J	€	G	FH	Fí	€	€	€	€	€	€	€	€	G
€FKÍ ÁÜT	€	í	F	í	€	í	H	J	€	H	€	H	€	€	€	€	FJ
€FKHÁÜT	€	F	€	F	€	í	í	FF	€	€	€	€	€	€	€	€	FG
€FKÍ ÁÜT	€	í	H	í	€	G	í	í	€	€	€	€	€	€	€	€	Fí
V[~]çã	€	FJ	í	G	€	Fí	G	IH	€	H	€	H	€	€	€	€	íF
€GKEÁÜT	€	H	G	í	€	F	í	í	€	F	€	F	€	€	€	€	FG
€GKÍ ÁÜT	€	í	H	í	€	G	í	J	€	G	€	G	€	€	€	€	Fí
€GKHÁÜT	€	í	€	í	€	í	í	FG	€	H	€	H	€	€	€	€	GH
€GKÍ ÁÜT	€	í	G	F€	€	G	í	í	€	€	€	€	€	€	€	€	Fí
V[~]çã	€	GH	í	H€	€	J	G	Hí	€	í	€	í	€	€	€	€	íF
Ö[~]áÁV[~]çã	€	I G	FH	íí	€	G	íH	íí	€	J	€	J	€	€	€	€	F I G
Qç :I&ÖÁ	€	ííÈ	GÈ	Á	€	HÈ	ííÈ	Á	€	F€€	€	Á	€	€	€	€	Á
V[~]çã	€	GÈ	JÈ	HÈ	€	FíÈ	HíÈ	ííÈ	€	íÈ	€	íÈ	€	€	€	€	€

ÜçãÁã ^	Úá:ÁUÖç^~^ Ú[~]cá[~]á				U&áÁÖ[~]çãá Y^•cá[~]á Y^•cá[~]á				Úá:ÁUÖç^~^ P[~]cá[~]á				U&áÁÖ[~]çãá Y^•cá[~]á Öçcá[~]á				QçÁV[~]çã
	Š~c	V@~	Üã@	Qç ÈV[~]çã	Š~c	V@~	Üã@	Qç ÈV[~]çã	Š~c	V@~	Üã@	Qç ÈV[~]çã	Š~c	V@~	Üã@	Qç ÈV[~]çã	
U^ãÁP[~]çã	€	H	G	í	€	F	í	í	€	F	€	F	€	€	€	€	FG
U^ãÁP[~]çã	€	í	3	í	€	G	í	J	€	G	€	G	€	€	€	€	Fí
U^ãÁP[~]çã	€	8	€	í	€	4	8	12	€	3	€	3	€	€	€	€	23
U^ãÁP[~]çã	€	í	G	10	€	G	í	í	€	€	€	€	€	€	€	€	Fí
V[~]çã	€	GH	í	H€	€	J	G	Hí	€	í	€	í	€	€	€	€	íF
U^ãÁP[~]çã	€	ííÈ	GÈH	Á	€	GÈ	ííÈH	Á	€	F€€	€	Á	€	€	€	€	Á
UPØ	€€€	ÈFJ	ÈíH	Èí€	€€€	ÈíH	ÈFH	ÈGí	€€€	È€€	€€€	È€€	€€€	€€€	€€€	€€€	ÈíG

Ó[~}oÁM|ãããÁQ&E
 UUÁQ|cÁFIÍ
 Ó[!|}ããÓÁGÍÍ
 Q|FÁGÍÈGÍ

Óã Á-Á[]*Á^ã&@
 ÐEJ|KÁ|A|Á|E^)^
 ÓEY KÁ &ã ÁQ| |^çããÁ ^•cà[~}á
 Y ^ã&@:KÁ| }}}

ÓE^Áã^ ^ KÓÓÓUQÓY T Ó
 ÚãÁQ[á^ KEEEEEEF
 ÚããÁQã^ KÁE BDEFG
 Úã^Á[K&

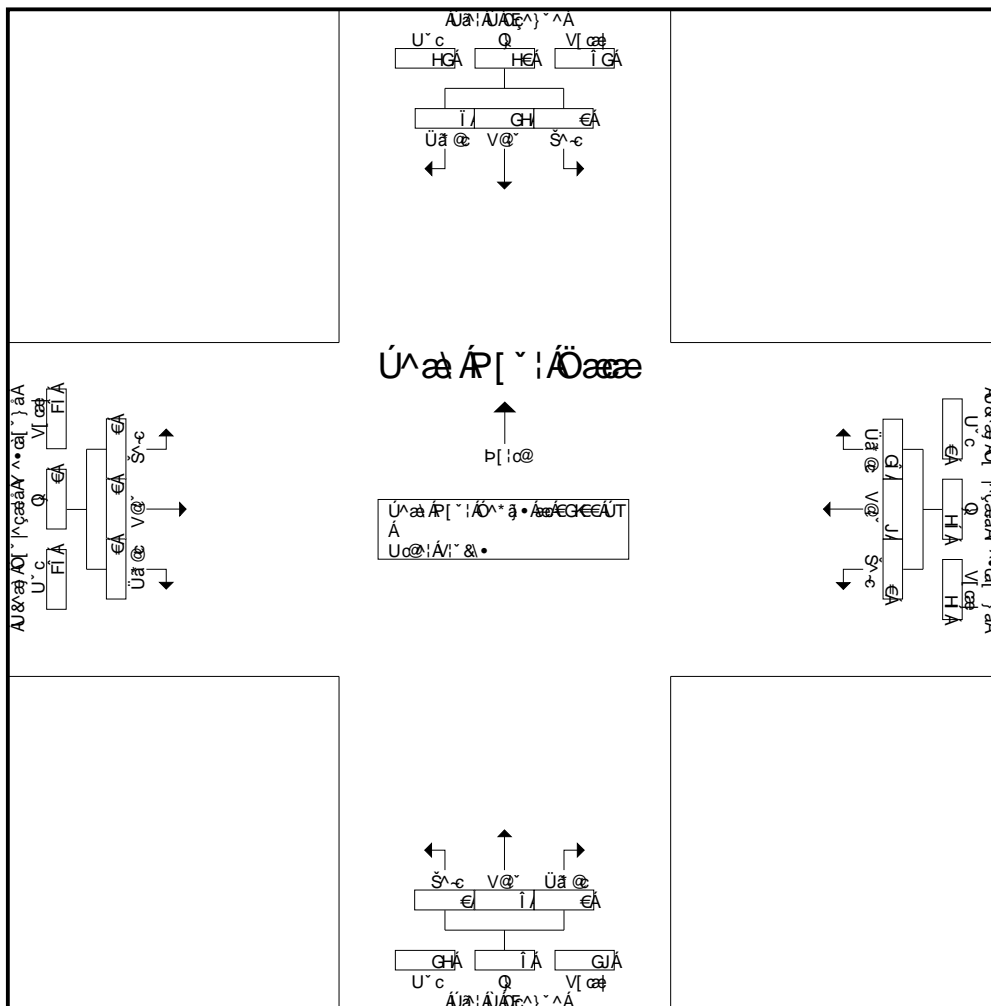

ÚããÁR[~|ÁQãã•ãÁQ[! EGEÁÚT Á EGEÁÚT ÁÚ^ããÁÁ-Á
 ÚããÁR[~|Á|ÁQããQ[!|ããÁQããÁ

	EGEÁÚT				EGEÁÚT				EGEÁÚT				EGEÁÚT			
ÉEÁ á•È	€	H	G	í	€	F	í	í	€	F	€	F	€	€	€	€
ÉFÁ á•È	€	I	3	í	€	G	í	J	€	G	€	G	€	€	€	€
ÉHEÁ á•È	€	8	€	í	€	4	8	12	€	3	€	3	€	€	€	€
ÉIÁ á•È	€	í	G	10	€	G	í	í	€	€	€	€	€	€	€	€
V çãK ^	€	GH	í	HE	€	J	G	H	€	í	€	í	€	€	€	€
Á ÁQ[EÁV çã	€	ííÈ	GíÈ	Á	€	GíÈ	ííÈ	Á	€	FEE	€	Á	€	€	€	€
UPØ	€€€€	ÈÈFJ	ÈÈH	ÈÈ€	€€€€	ÈÈH	ÈÈFH	ÈÈGJ	€€€€	ÈÈ€€	€€€€	ÈÈ€€	€€€€	€€€€	€€€€	€€€€

Ó[~}•ÁM|ãããQ&É
 UUÁQ|cÁFíí
 Ó[íí]ããÖÖÁGíí
 QíFíGííÉíí

Óã Á-Áí}•Á^ã&@
 ÞÉUÁUã:ÁU/ÖE^}^
 ÖEY KÁU&ã ÁQí |^çããÁ Á•cã[~}ã
 Y^ã&@:KÁU}}}

ÖE^Áã ^ KÖÓÓUWÓY ÚT
 Úã ÁQí á^ KÉÉÉÉÉÉÉF
 Úãã ÖÖãã KÁÞBDEFG
 Úãã ^ÁQí K&G

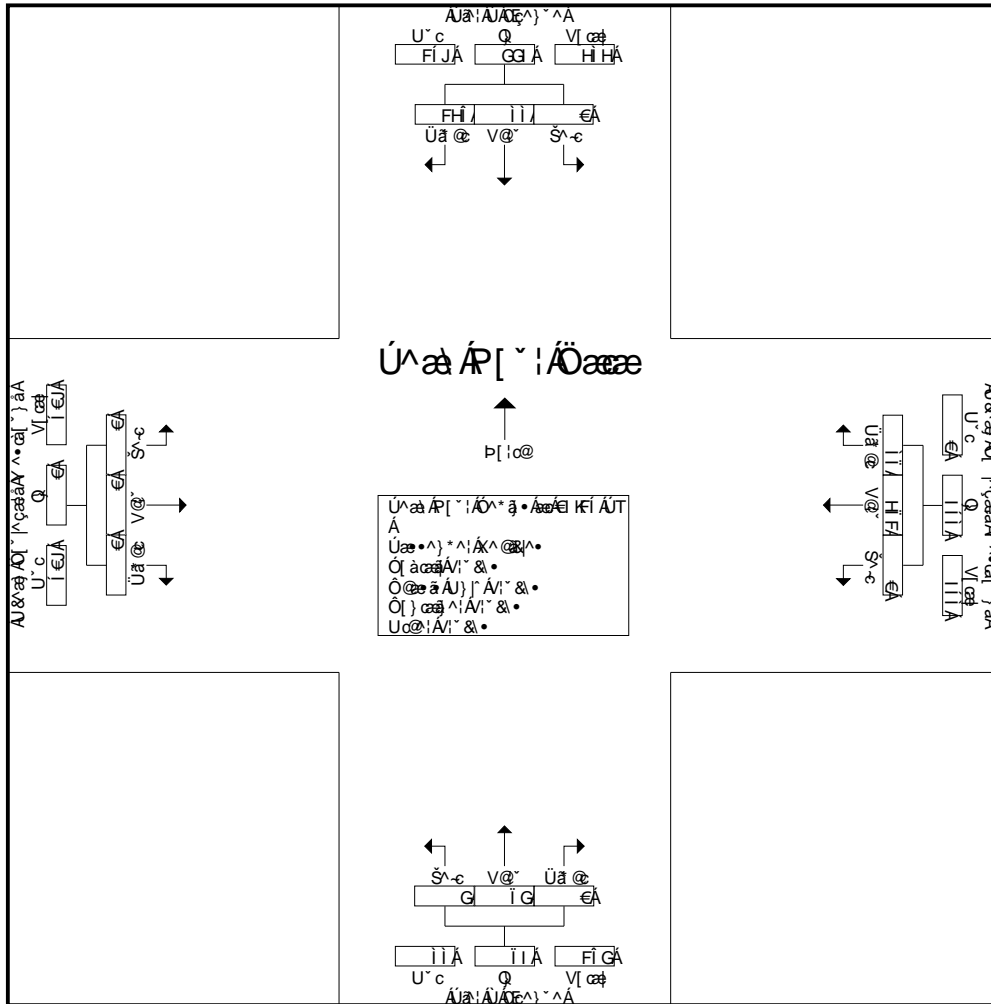

Úã ÁQí |^ÖÖãæ • Áãã Kí ÁÚT Áã Kí ÁÚT Áã Úã ÁQí |^ÖÖãæ
 Úã ÁQí |^ÖÖãæ • Áãã Kí ÁÚT Áã Kí ÁÚT Áã Úã ÁQí |^ÖÖãæ

	eí Kí ÁÚT				eí Kí ÁÚT				eí Kí ÁÚT				eí Kí ÁÚT			
ÉÉÁ á•É	€	Fí	G	I H	€	íí	GF	Jí	1	GF	€	GG	€	€	€	€
ÉFí Á á•É	€	GF	GF	I G	€	Jí	25	FFJ	€	GH	€	GH	€	€	€	€
ÉHÉ Á á•É	€	26	56	82	€	102	G	126	€	Fí	€	Fí	€	€	€	€
Éíí Á á•É	€	G	HH	íí	€	F€€	Fí	FFí	F	24	€	25	€	€	€	€
Ví çãK[~}^	€	íí	FHí	GG	€	HíF	íí	ííí	G	íí	€	íí	€	€	€	€
Á ÁQí ^ÖÖãæ	€	HJÉH	ííÉ	Á	€	íF	FJ	Á	GH	JíÉ	€	Á	€	€	€	€
ÚPÖ	€€€€	Éíí	Éíí	Éíí	€€€€	Éíí	Éíí	Éíí	€€€€	Éíí	€€€€	Éíí	€€€€	€€€€	€€€€	€€€€

Ó[~], ÁM|ã äáÁ&É
 UUÁŒ cÁFI
 Ó[~] äÖÖÁGÍ
 QIFDÍÉÍ

Óä Á-Á[~]*ÁŒä@
 ÞDUÁŒ:ÁŒŒ^ ^
 ÖY KÁŒ:áŒ[~]ŒçääÁ ^•cá[~] ä
 Y ^ä@:KÁ[~]}}

ÖY ÁŒ ^ KÖÖÖÖÖÖÖ ÖY ÚT
 Úä ÁŒ ä KÖÖÖÖÖÖF
 Úçä ÖŒ KÖÖÖÖÖFG
 Úçä ÁŒ KÖ

Ö[~]•ÁŒã äáŒŒ•^)*Á:ÁŒŒ•

Úçä ÖÁŒ ^	Úä:ÁŒŒ^ ^ Ú[~]cá[~] ä				U&Œ ÁŒ[~]Œçää Y ^•cá[~] ä Y ^•cá[~] ä				Úä:ÁŒŒ^ ^ P[~]cá[~] ä				U&Œ ÁŒ[~]Œçää Y ^•cá[~] ä Öçä cá[~] ä				Q äŒ[~]	
	Š-c	V@~	Üä @	Q äŒ[~]	Š-c	V@~	Üä @	Q äŒ[~]	Š-c	V@~	Üä @	Q äŒ[~]	Š-c	V@~	Üä @	Q äŒ[~]		
€ K€ÁŒT	€	í	F€	FI	€	G	í	H	€	I	€	I	€	€	€	€	€	í
€ Kí ÁŒT	€	í	GF	GJ	€	HH	FF	II	€	í	€	í	€	€	€	€	€	í J
€ K€ÁŒT	€	J	Fí	G	€	Ií	Fí	ÍG	€	FG	€	FG	€	€	€	€	€	Jí
€ Kí ÁŒT	€	GF	íG	íH	€	Ií	Fí	ÍG	F	GF	€	GG	€	€	€	€	€	Fíí
V[~]	€	Ií	Jí	FíH	€	Fíí	Ií	GEG	F	IH	€	Ií	€	€	€	€	€	HíJ
€ K€ÁŒT	€	GG	GJ	íF	€	IJ	FF	í€	€	G€	€	G€	€	€	€	€	€	FHF
€ Kí ÁŒT	€	FH	í	GF	€	HJ	í	Ií	€	Fí	€	Fí	€	€	€	€	€	íH
€ K€ÁŒT	€	í	í	FF	€	Gí	J	Hí	€	GH	€	GH	€	€	€	€	€	í€
€ Kí ÁŒT	€	€	I	I	€	HF	í	Hí	€	FH	€	FH	€	€	€	€	€	íí
V[~]	€	I€	Ií	íí	€	Fíí	Hí	FíF	€	íF	€	íF	€	€	€	€	€	HU
Ö:ä äÁŒ[~]	€	íí	Fíí	G€	€	H€G	íF	HíH	F	FFI	€	FFí	€	€	€	€	€	íG
Q : & ÁŒ	€	Hí	íH	Á	€	ííÉ	G€É	Á	€	JJÉ	€	FíÁ	€	€	€	€	€	Á
V[~]	€	FFÉ	FJÉ	HFÉ	€	IÉÉ	FFÉ	íGÉ	€	FíÉ	€	FíÉ	€	€	€	€	€	Á

Úçä ÖÁŒ ^	Úä:ÁŒŒ^ ^ Ú[~]cá[~] ä				U&Œ ÁŒ[~]Œçää Y ^•cá[~] ä Y ^•cá[~] ä				Úä:ÁŒŒ^ ^ P[~]cá[~] ä				U&Œ ÁŒ[~]Œçää Y ^•cá[~] ä Öçä cá[~] ä				Q äŒ[~]	
	Š-c	V@~	Üä @	Q äŒ[~]	Š-c	V@~	Üä @	Q äŒ[~]	Š-c	V@~	Üä @	Q äŒ[~]	Š-c	V@~	Üä @	Q äŒ[~]		
Úçä ÁŒ[~]: ÁŒ[~] ä•á ÁŒ[~] { ÁŒ Kí ÁŒT ÁŒ Kí ÁŒT ÁŒ Kí ÁŒT ÁŒ Kí ÁŒT																		
€ Kí ÁŒT	€	í	GF	GJ	€	HH	FF	II	€	í	€	í	€	€	€	€	€	í J
€ K€ÁŒT	€	J	Fí	G	€	Ií	15	62	€	FG	€	FG	€	€	€	€	€	Jí
€ Kí ÁŒT	€	GF	52	73	€	Ií	Fí	ÍG	€	1	21	€	22	€	€	€	€	157
€ K€ÁŒT	€	22	GJ	íF	€	49	FF	í€	€	G€	€	G€	€	€	€	€	€	FHF
V[~]K[~]Œ[~]	€	í€	FFí	Fíí	€	Fíí	íF	G€	F	íJ	€	í€	€	€	€	€	€	íí
Á ÁŒ[~] äŒ[~]	€	HÉ	ííÉ	Á	€	ííÉ	G€É	Á	€	FíÉ	JíÉ	€	FíÉ	€	€	€	€	Á
UPØ	€€€	ÉíG	ÉíH	Éí	€€€	É€H	Éí€	ÉFJ	€€	É€G	€€€	ÉíG	€€€	€€€	€€€	€€€	€€€	Éí€

Ó[~] ◦ ÁM | á á a A Q & E
 UU A Q c A F I I
 Ó [! !] á á Ó Á G I I
 Q I F D Á I É É I

Ó á Á - Á [] * A ^ á á @
 P B U K Á Á : A U A C E ^ } ^
 O E Y K Á U & á Á [] ^ ç á á Á ^ * á [~] á
 Y ^ á @ : K Á } }

Ó Á P á ^ K S Ó Ú U Ó Y Ú T
 Ú á Á [] á ^ K E E E E E E F
 Ú á á Á P á ^ K A B B E F G
 Ú á á Á P [] K G

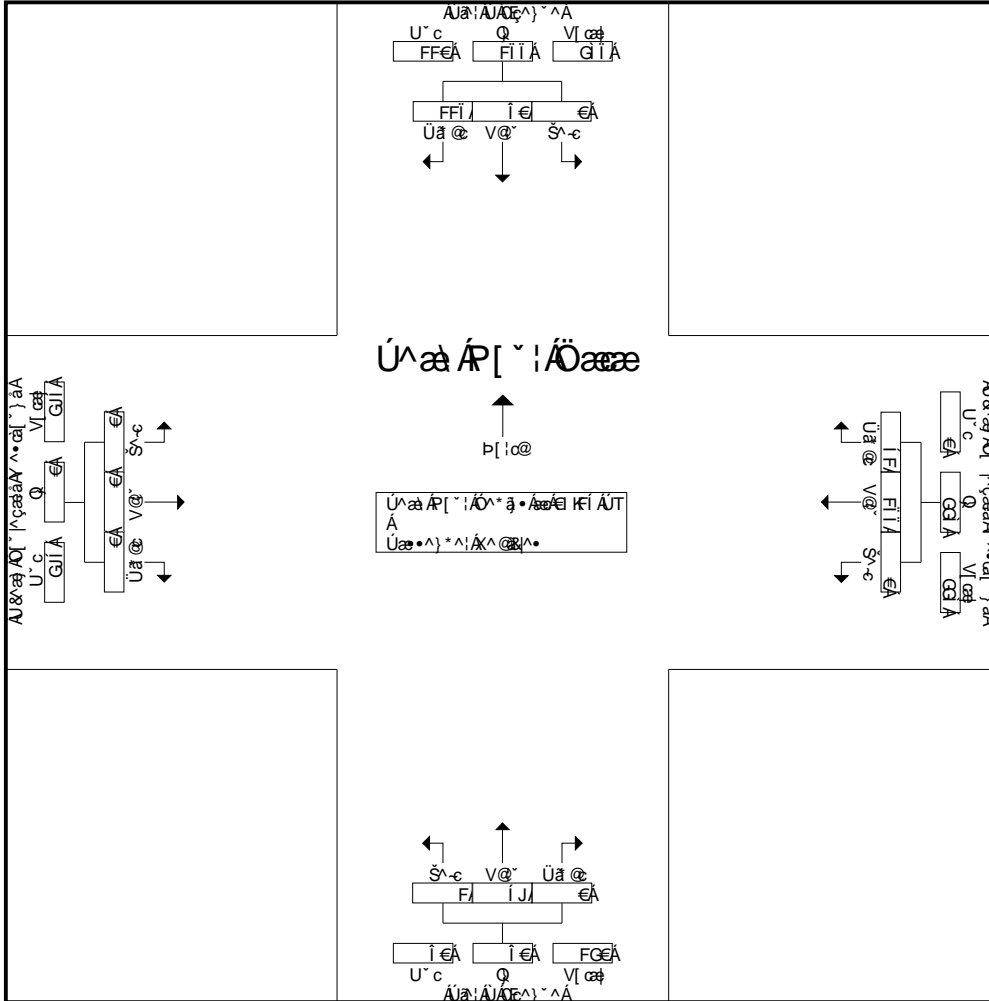

Ú á á Á P [~] Á Ö á á é Á [] (Á I K I Á T Á Á K E Á T Á Á Ú á á Á Á - Á
 Ú á á Á P [~] Á Á [] (Á Ö á á é) [] á á Á Ö * á * Á K

€€ € á • È	€	Ì	GF	GJ	€	HI	FF	II	€	Î	€	Î	€	€	€	€
É F I Á á • È	€	J	F I	G	€	I I	15	62	€	FG	€	FG	€	€	€	€
É H Á á • È	€	GF	52	73	€	I I	FI	I G	1	21	€	22	€	€	€	€
É I Á á • È	€	22	GJ	I F	€	49	FF	I é	€	GE	€	GE	€	€	€	€
V I ç á K [] ^	€	I é	F F I	F I I	€	F I I	I F	G G	F	I J	€	I é	€	€	€	€
Á Á [] É V I ç á	€	H É	I I É	Á	€	I I É	G G É	Á	F É	J I É	€	Á	€	€	€	Á
Ú P Ø	€€€	É I G	É I H	É É	€€€	É H	É I é	É F J	€	É G	€€€	É I G	€€€	€€€	€€€	€€€

Ö [^] . o Á M j ä ä a Q & E
 UU A Ö c A F F I
 Ö [(]) a & O c a G i i
 Q I F D G i È G I

Ö a r Á - A [^] * A O a a @
 P B U I K U J a : A U A Ö c A ^ } ^ ^
 O E Y K U J & a a A Ö [^] c a a A ^ . a [^] a
 Y ^ a a @ : K U } } ^

Ö a r A a a ^ K S O U U W Ö Y U T
 U a r A Ö [a ^ K E E E E E E F
 U c a a Ö a a K H B D E F G
 U a a ^ A r [K F

Ö [^] . Á U : ä c a È Ö [a a a Á i ^ & .

Ü c a a Ö A ä ^	Ú a : Á U A Ö c A ^ } ^ ^ Ú [^ c a [^] a				U & a a A Ö [^] c a a Y ^ . a [^] a Y ^ . a [^] a				Ú a : Á U A Ö c A ^ } ^ ^ P [! c a [^] a				U & a a A Ö [^] c a a Y ^ . a [^] a Ö a a c a [^] a				Q d a V c a a
	Š ^ - c	V @ ^	Ü ä @	Q j] È V [c a a	Š ^ - c	V @ ^	Ü ä @	Q j] È V [c a a	Š ^ - c	V @ ^	Ü ä @	Q j] È V [c a a	Š ^ - c	V @ ^	Ü ä @	Q j] È V [c a a	
€ K E A U T	€	í	í	FG	€	Fí	€	Fí	€	H	€	H	€	€	€	€	HF
€ K í Á U T	€	í	í	J	€	FJ	€	G€	€	G	€	G	€	€	€	€	HF
€ K H E A U T	€	í	í	FF	€	Gí	€	í HF	€	í	€	í	€	€	€	€	í í
€ K í Á U T	€	€	F	F	€	GJ	€	G HF	€	€	€	€	€	€	€	€	HG
V [c a a	€	Fí	Fí	HH	€	í J	€	J í	€	J	€	J	€	€	€	€	Fí €
€ K E A U T	€	€	H	H	€	G	€	Gí	€	F	€	F	€	€	€	€	HF
€ K í Á U T	€	€	F	F	€	G€	€	G€	€	€	€	€	€	€	€	€	GF
€ K H E A U T	€	F	€	F	€	GG	€	GH	F	€	€	F	€	€	€	€	Gí
€ K í Á U T	€	€	F	F	F	FJ	€	F GF	€	€	€	€	€	€	€	€	GG
V [c a a	€	F	í	í	F	í í	€	í JF	F	F	€	G	€	€	€	€	JJ
Ö ! a a A U [c a a	€	Fí	GF	HU	€	F Fí	€	Fí J	F	F€	€	FF	€	€	€	€	GHU
Q j] : & A A	€	í í È	í H È	Á	€	È J G È	€	í È Á	J È	J È	€	Á	€	€	€	€	Á
V [c a a	€	í È	í È	Fí È	€	È í G È	€	í J È	È	í È	€	í È	€	€	€	€	Á

Ü c a a Ö A ä ^	Ú a : Á U A Ö c A ^ } ^ ^ Ú [^ c a [^] a				U & a a A Ö [^] c a a Y ^ . a [^] a Y ^ . a [^] a				Ú a : Á U A Ö c A ^ } ^ ^ P [! c a [^] a				U & a a A Ö [^] c a a Y ^ . a [^] a Ö a a c a [^] a				Q d a V c a a
	Š ^ - c	V @ ^	Ü ä @	Q j] È V [c a a	Š ^ - c	V @ ^	Ü ä @	Q j] È V [c a a	Š ^ - c	V @ ^	Ü ä @	Q j] È V [c a a	Š ^ - c	V @ ^	Ü ä @	Q j] È V [c a a	
U a a A r [^] : A Ö a a . a A Ö [{ A í K í Á U T A í K E A U T A U a a F A F	€	í	4	J	€	FJ	€	G€	€	G	€	G	€	€	€	€	HF
U a a A r [^] : A í A Ö) c a ^ A c ! ^ & c a } A Ö * a . A a A í K í Á U T	€	7	í	11	€	Gí	€	6 31	€	4	€	4	€	€	€	€	46
	€	€	F	F	€	29	€	G HF	€	€	€	€	€	€	€	€	HG
	€	€	H	H	€	G	€	H Gí	€	F	€	F	€	€	€	€	HF
V [c a a X [] ^	€	FG	FG	G	€	Jí	€	FG F€J	€	í	€	í	€	€	€	€	Fí €
Á A Ö] È V [c a a	€	í €	í €	Á	€	í J	€	FF Á	€	F€€	€	Á	€	€	€	€	Á
U P Ø	È È È	È GJ	È í €	È í í	È È È	È H	È È €	È í J	È È È	È H	È È È	È H	È È È	È È È	È È È	È È È	È È F

Ó[~}, oÁM|ã, äããQ&É
 UUÁQ, cÁFFÍ
 Ó[!;!} äããOÁGÍí
 Q! FÁGÍ È Ì

Óã Á, -Á[] * Á^ã&
 ÞÉJKAÚã: ÁU/ÖE^ ^ ^
 ÖEY KÁU & ð ÁÚ [^ çããÁ Á • cã [^ } á
 Y ^ã&@: KÁU } } ^

ÓEÁ Þã ^ KÓÓÓÚWÓY ÚT
 Úã ÁÚ [á ^ KÉÉÉÉÉÉÉÉÉF
 ÚããÁÓãã KÁ Þ BDEFG
 Úãã Á Þ K&

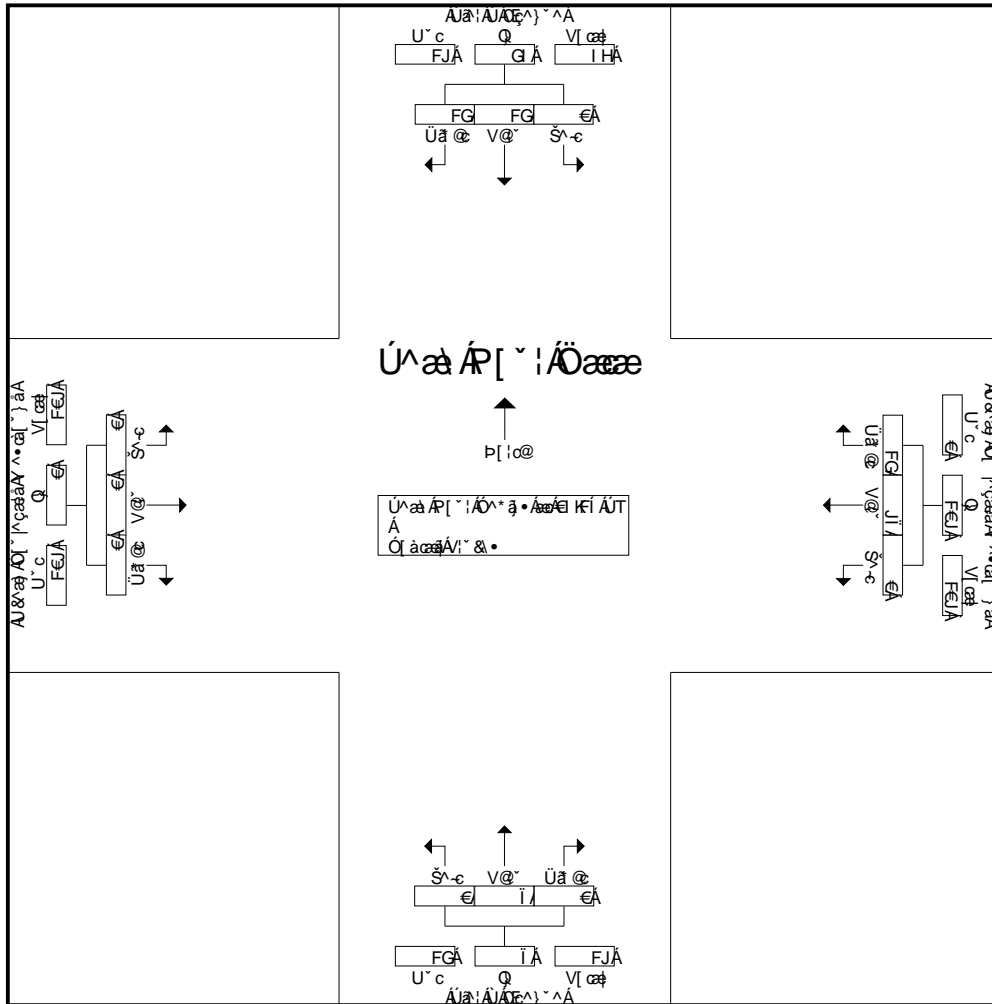

Úãã ÁR [~ ! Öãã Á • ÁÚ [{ Á KFI ÁÚT Á Á KFI ÁÚT ÁÚãã Á Á - Á
 Úãã ÁR [~ ! ÁV [Öãã ÖÁ] ! ; äããOÁ * ä • ÁãK

	ei KFI ÁÚT				ei KFI ÁÚT				ei KFI ÁÚT				ei KFI ÁÚT			
ÉÉÁ ä • È	€	í	4	J	€	FJ	F	QÉ	€	G	€	G	€	€	€	€
ÉFÍ Á ä • È	€	7	I	11	€	G	6	31	€	4	€	4	€	€	€	€
ÉHEÁ ä • È	€	€	F	F	€	29	G	HF	€	€	€	€	€	€	€	€
ÉÍ Á ä • È	€	€	H	H	€	G	H	G	€	F	€	F	€	€	€	€
V [çãK] { ^	€	FG	FG	G	€	JÍ	FG	FÉJ	€	í	€	í	€	€	€	€
Á ÁÚ [ÉV [çã	€	í	í	Á	€	íJ	FF	Á	€	FEE	€	Á	€	€	€	€
UÞØ	€€€	ÈG	Èí	ÈÍ	€€€	ÈH	È€€	ÈíJ	€€€	ÈH	€€€	ÈH	€€€	€€€	€€€	€€€

Ô[~],ÔÁY|ãããÁQ&É
 UUÁÔçÁFÍÍ
 Ô[~]ãÖÖçÁGíí
 ÇÍFDGíÈGí

ÔãÁ-Á[~]*ÁÔãã@
 ÞÐUÁUÁ:ÁUÁÔçÁ~^
 ÖYÁU&ãÁÔ[~]çããÁ^•ã[~]ã
 Y^ãã@:ÁU}}^

ÖYÁÔã^KÖÓÓUÓÓYÚT
 UÁÁÔ[~]ãKÖÖÖÖÖÖF
 UçãÁÔãKÁHÞBDFG
 UçãÁÔ[~]KÖ

Ô[~]•ÁUãããÖÖçÁU}}Á/•&•

UçãÁUã^	UÁ:ÁUÁÔçÁ~^ U[~]çã[~]ã				U&ãÁÔ[~]çããÁ Y^•ã[~]ã Y^•ã[~]ã				UÁ:ÁUÁÔçÁ~^ P[~]çã[~]ã				U&ãÁÔ[~]çããÁ Y^•ã[~]ã Öçãã[~]ã				QçÁV[~]çã
	Š~c	V@~	Üã@	Ç[~]ÈV[~]çã	Š~c	V@~	Üã@	Ç[~]ÈV[~]çã	Š~c	V@~	Üã@	Ç[~]ÈV[~]çã	Š~c	V@~	Üã@	Ç[~]ÈV[~]çã	
€ KEEÁÚT	€	F	€	F	€	I	I	FF	€	F	€	F	€	€	€	€	FH
€ KÍÁÚT	€	€	€	€	€	I	H	I	€	€	€	€	€	€	€	€	I
€ KHEÁÚT	€	F	€	F	€	G	€	G	€	€	€	€	€	€	€	€	H
€ KÍÁÚT	€	F	€	F	€	€	€	€	€	€	€	€	€	€	€	€	F
V[~]çã	€	H	€	H	€	FF	F€	GF	€	F	€	F	€	€	€	€	G
€ KEEÁÚT	€	€	€	€	€	H	€	H	€	€	€	€	€	€	€	€	H
€ KÍÁÚT	€	€	€	€	€	H	€	H	€	€	€	€	€	€	€	€	H
€ KHEÁÚT	€	€	€	€	€	F	F	G	€	€	€	€	€	€	€	€	G
€ KÍÁÚT	€	€	€	€	€	G	€	G	€	€	€	€	€	€	€	€	G
V[~]çã	€	€	€	€	€	J	F	F€	€	€	€	€	€	€	€	€	F€
Ô[~]ãÁV[~]çã	€	H	€	H	€	G€	FF	H€	€	F	€	F	€	€	€	€	H
Ç[~]Í&çÁ	€	F€€	€	Á	€	ííÈ	HÈ	Á	€	F€€	€	Á	€	€	€	€	Á
V[~]çã	€	íÈ	€	íÈ	€	ííÈ	HÈ	ííÈ	€	G€	€	G€	€	€	€	€	Á

UçãÁUã^	UÁ:ÁUÁÔçÁ~^ U[~]çã[~]ã				U&ãÁÔ[~]çããÁ Y^•ã[~]ã Y^•ã[~]ã				UÁ:ÁUÁÔçÁ~^ P[~]çã[~]ã				U&ãÁÔ[~]çããÁ Y^•ã[~]ã Öçãã[~]ã				QçÁV[~]çã
	Š~c	V@~	Üã@	Ç[~]ÈV[~]çã	Š~c	V@~	Üã@	Ç[~]ÈV[~]çã	Š~c	V@~	Üã@	Ç[~]ÈV[~]çã	Š~c	V@~	Üã@	Ç[~]ÈV[~]çã	
UÁ:ÁV[~]çã	€	€	€	€	€	5	3	8	€	€	€	€	€	€	€	€	8
€ KÍÁÚT	€	€	€	€	€	G	€	G	€	€	€	€	€	€	€	€	H
€ KHEÁÚT	€	1	€	1	€	€	€	€	€	€	€	€	€	€	€	€	F
€ KÍÁÚT	€	F	€	F	€	€	€	€	€	€	€	€	€	€	€	€	H
€ KEEÁÚT	€	€	€	€	€	H	€	H	€	€	€	€	€	€	€	€	H
V[~]çãKÍÁÚT	€	G	€	G	€	F€	H	FH	€	€	€	€	€	€	€	€	F
ÁÁÔ[~]ÈV[~]çã	€	F€€	€	Á	€	ííÈ	GÈ	Á	€	€	€	€	€	€	€	€	Á
UPØ	€€€	È€€	€€€	È€€	€€€	È€€	€€	È€	€€€	€€€	€€€	€€€	€€€	€€€	€€€	€€€	ÈÍJ

Ó[] , o ÁM | á , á a Q & E
 UU Á Q c A F I I
 Ó [:] } á á Ö Ö Á G I i
 Q I F D G i E é I

Ó á Á - Á [] * Á ^ á @
 P B U K Á : Á / Ö E ^ ^
 Ö E Y K Á & á Á [] ^ ç á á Á ^ * á [^] á
 Y ^ á @ : K Á } }

Ö Á ^ á ^ K S Ó Ó U W Ö Y Ú T
 Ú á Á [] á ^ K E E E E E E F
 Ú á á Ö á K B B E F G
 Ú á ^ Á [] K G

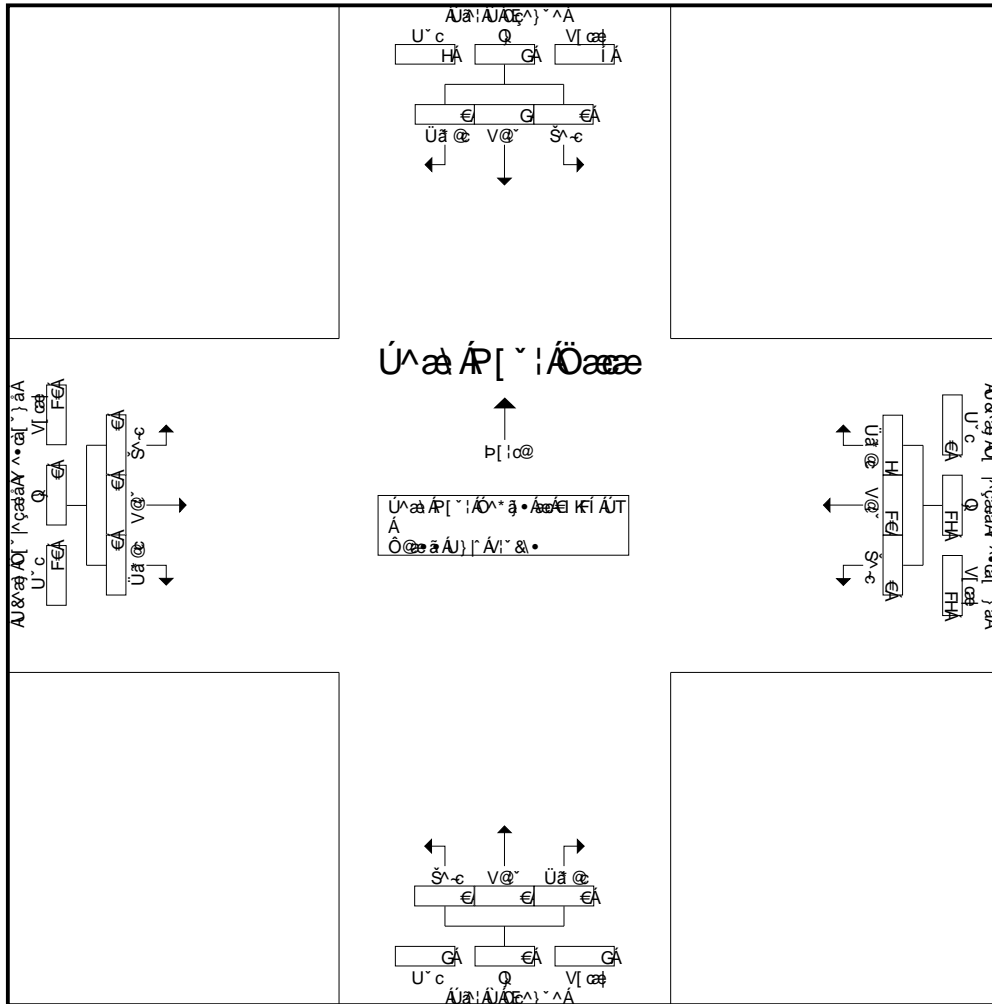

Ú á á Á R [^ | Á Ö á á Á Á [] K I Á Ú T Á Á K E Á Ú T Á Á U á á Á Á - Á
 Ú á á Á R [^ | Á Ö á á Á Á [] á á Ö * á * Á á K

É e Á á • È	€	€	€	€	€	5	3	8	€	€	€	€	€	€	€	€	€
É F I Á á • È	€	1	€	1	€	€	G	€	€	€	€	€	€	€	€	€	€
É H E Á á • È	€	F	€	F	€	€	€	€	€	€	€	€	€	€	€	€	€
É I Á á • È	€	€	€	€	€	€	H	€	H	€	€	€	€	€	€	€	€
V [ç á K] ^	€	G	€	G	€	F E	H	F H	€	€	€	€	€	€	€	€	€
Á Á [] V [ç á	€	F E	€	Á	€	í í È	G H	Á	€	€	€	€	€	€	€	€	Á
U P Ø	€ € €	€ € €	€ € €	€ € €	€ € €	€ € €	€ € €	€ € €	€ € €	€ € €	€ € €	€ € €	€ € €	€ € €	€ € €	€ € €	€ € €

Ó[~]•ÁM|ããáÁ&É
 ÚUÁÓ|çÁFÍÍ
 Ó[~]•ááÖÖáGíí
 QI FDI È G I

Óã Á -Á[] * Á^ãã@
 ÞÞUÁÚ:Á/ÁÇ^)^ ^
 ÖY KÁ&ã Á[] ^çãáÁ ^•cã[] á
 Y ^ãã@:KÁ } } ^

ÖY Á ç ^ KÖÓÓÚÓÝ ÚT
 Úã Á[] á^ KÇÇÇÇÇÇÇF
 Úãç Öã KÁ Þ BDFG
 Úã ^ Á[] KÇ

Ö[~]•ÁÚãçááÖ[~]•çã^!ÁV!&•

ÚãçÁ/ã ^	Úã:Á/ÁÇ^)^ ^ Ú[~]•cã[~]•} á				U&ã Á[~] ^çãá Y ^•cã[~]•} á Y ^•cã[~]•} á				Úã:Á/ÁÇ^)^ ^ Þ[~]•cã[~]•} á				U&ã Á[~] ^çãá Y ^•cã[~]•} á Öã çã[~]•} á				Q çã[~]•} á
	Š~c	V@~	Üã @	Q[] ÈV[] çã	Š~c	V@~	Üã @	Q[] ÈV[] çã	Š~c	V@~	Üã @	Q[] ÈV[] çã	Š~c	V@~	Üã @	Q[] ÈV[] çã	
€ K€ÁÚT	€	G	€	G	€	FÍ	H	FÍ	€	F	€	F	€	€	€	€	€
€ KÍ ÁÚT	€	G	€	G	€	FÍ	I	GF	€	F	€	G	€	€	€	€	€
€ K€ÁÚT	€	G	F	H	€	FJ	I	GH	€	€	€	€	€	€	€	€	€
€ KÍ ÁÚT	€	G	G	I	€	G	I	GÍ	€	€	€	€	€	€	€	€	€
V[] çã	€	I	H	FF	€	ÍI	FÍ	ÍJ	F	G	€	H	€	€	€	€	€
€ K€ÁÚT	€	G	F	H	€	G	H	GÍ	€	€	€	€	€	€	€	€	€
€ KÍ ÁÚT	€	€	F	F	€	FJ	I	GÍ	€	F	€	F	€	€	€	€	€
€ K€ÁÚT	€	€	€	€	€	GÍ	I	HÍ	€	€	€	€	€	€	€	€	€
€ KÍ ÁÚT	€	€	€	€	€	HF	€	HF	€	€	€	€	€	€	€	€	€
V[] çã	€	G	G	I	€	FEG	FI	FFÍ	€	F	€	F	€	€	€	€	€
Ö!ã áÁ[] çã	€	F€	I	FÍ	€	FÍÍ	GJ	GÍ	F	H	€	I	€	€	€	€	€
Q[] :&ÖÁ	€	ÍÍÈ	HÈH	Á	€	ÍÍÈ	FIÈ	Á	GÍ	ÍÍ	€	Á	€	€	€	€	Á
V[] çã	€	IÈ	GÈG	ÍÈ	€	ÍÍÈ	FCÈ	JFÈ	ÈÈ	FÈH	€	FÈ	€	€	€	€	€

ÚãçÁ/ã ^	Úã:Á/ÁÇ^)^ ^ Ú[~]•cã[~]•} á				U&ã Á[~] ^çãá Y ^•cã[~]•} á Y ^•cã[~]•} á				Úã:Á/ÁÇ^)^ ^ Þ[~]•cã[~]•} á				U&ã Á[~] ^çãá Y ^•cã[~]•} á Öã çã[~]•} á				Q çã[~]•} á
	Š~c	V@~	Üã @	Q[] ÈV[] çã	Š~c	V@~	Üã @	Q[] ÈV[] çã	Š~c	V@~	Üã @	Q[] ÈV[] çã	Š~c	V@~	Üã @	Q[] ÈV[] çã	
Úãç Á[~] :Á[] çã	€	2	€	G	€	FÍ	4	GF	1	1	€	2	€	€	€	€	GÍ
Úãç Á[~] :Á[] çã	€	G	F	H	€	FJ	I	GH	€	€	€	€	€	€	€	€	GÍ
Úãç Á[~] :Á[] çã	€	G	2	4	€	24	I	28	€	€	€	€	€	€	€	€	32
Úãç Á[~] :Á[] çã	€	G	F	H	€	G	H	GÍ	€	€	€	€	€	€	€	€	H€
V[] çãK[] ^	€	I	I	FG	€	ÍI	FÍ	JJ	F	F	€	G	€	€	€	€	FFH
Á Á[] ÈV[] çã	€	ÍÍÈ	HÈH	Á	€	ÍÍÈ	FÍÈ	Á	Í€	Í€	€	Á	€	€	€	€	Á
UPØ	ÈÈÈ	FÈÈ	ÈÈÈ	ÈÈ€	ÈÈÈ	ÈÈÍ	ÈÈH	ÈÈI	ÈÈ€	ÈÈ€	ÈÈÈ	ÈÈ€	ÈÈÈ	ÈÈÈ	ÈÈÈ	ÈÈÈ	ÈÈH

Ó[~}•ÁM|ãããã&É
 UUÁQ|cÁFíí
 Ó[!:]ããããããíí
 Qíííííííííí

Óã Á -Á[]*Á^ã&@
 ÞÉJÁÚã:ÁÚÁÉ^~^
 ÖÉY KÁÚ&ã ÁÚ[]^çããÁ ^•cã[~}ã
 Y^ã&@:KÁU}}^

ÖÉ Á þã ^ KÓÓÓÚÚÓY ÚT
 Úã ÁÚ[]ã KÉÉÉÉÉÉÉÉÉÉÉÉ
 ÚããÁÖãã KÁÞBDEFG
 Úãã^ÁÚ[]K&

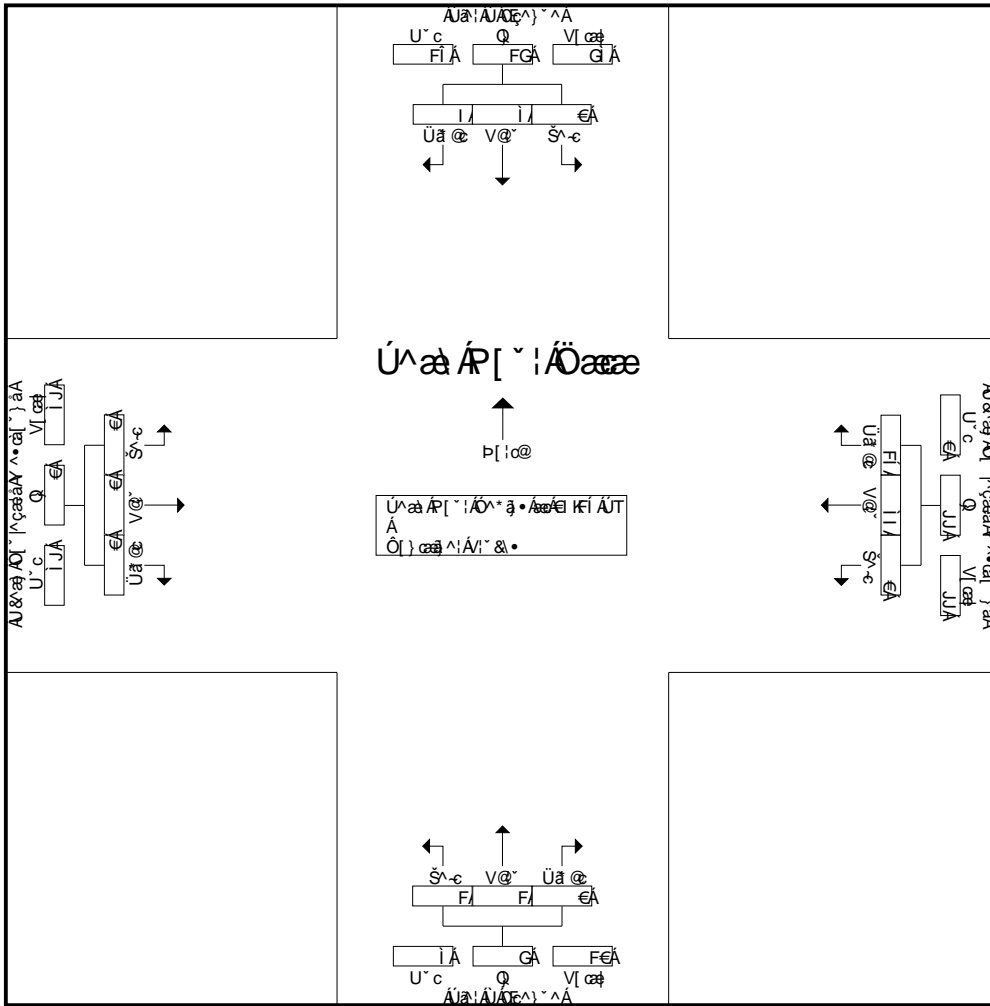

Úãã ÁÚ[]^!Öããæ •ã ÁÚ[]{ Áí Kí ÁÚT Áí Áí KÉÁÚT ÁÚÚãã ÁÚÁ -Á
 Úãã ÁÚ[]^!ÁÚ[]ÖããÖÁÚ[]!|ããÖÁ^ã •ÁÚK

	€	2	€	G	€	Fí	4	GF	1	1	€	2	€	€	€	€	€
ÉÉÁ ã •É	€	G	F	H	€	FJ	I	GH	€	€	€	€	€	€	€	€	€
ÉFí Á ã •É	€	G	F	H	€	G	H	G	€	€	€	€	€	€	€	€	€
ÉHÉÁ ã •É	€	G	F	H	€	G	H	G	€	€	€	€	€	€	€	€	€
Éí Á ã •É	€	G	F	H	€	G	H	G	€	€	€	€	€	€	€	€	€
Ví çãK[]^	€	í	I	FG	€	íí	Fí	JJ	F	F	€	G	€	€	€	€	€
Á ÁÚ[]ÉVí çã	€	íí	É	HÉH	€	íí	Fí	ÉG	í	€	€	€	Á	€	€	€	€
ÚPØ	€€€	F€€€	É€€	Éí€	€€€	Éíí	ÉHí	Éíí	€€€	€€€	€€€	€€€	€€€	€€€	€€€	€€€	€€€

Ö[~]•ÁM|ãããÁQ&É
 UUÁÖ|çÁFÍÍ
 Ö[~]•áÖÖçÁGÍÍ
 QIFDÖIÉGI

Öã Á-Á[~]•ÁÖã@
 ÞDUKÁJã:ÁUÖç^)^
 ÖEY KÁU&ã ÁÖ[~]çããÁ Á•cã[~]ã
 Y^ã@:KÁ}}^

ÖE Áã ^ KÖÓÓÚÓÓY ÚT
 Úã ÁÖ[~]ã KÉÉÉÉÉÉÉF
 Úcã Öã KÁÞBDEFG
 Úã ÁÁ[~] K&

Ö[~]•ÁUã çãÁUc@:ÁM' &•

Úcã ÖÁã ^	Úã:ÁUÖç^)^ Ú[~]cã[~]ã				U&ã ÁÖ[~]çãã Y^•cã[~]ã Y^•cã[~]ã				Úã:ÁUÖç^)^ P[~]cã[~]ã				U&ã ÁÖ[~]çãã Y^•cã[~]ã Öã cã[~]ã				Q çã[~]ã	
	Š~c	V@~	Üã @	ç[~]ÉV[~]çã	Š~c	V@~	Üã @	ç[~]ÉV[~]çã	Š~c	V@~	Üã @	ç[~]ÉV[~]çã	Š~c	V@~	Üã @	ç[~]ÉV[~]çã		
É KÉÁÚT	€	I	F	Í	€	H	F	I	€	F	€	F	€	€	€	€	€	F€
É KÍ ÁÚT	€	G	F	H	€	F	G	H	€	F	€	F	€	€	€	€	€	í
É KÉÁÚT	€	G	F	H	€	F	€	F	€	G	€	G	€	€	€	€	€	í
É KÍ ÁÚT	€	G	F	H	€	F	I	Í	€	€	€	€	€	€	€	€	€	í
V[~]çã	€	F€	I	FI	€	Í	Í	FH	€	I	€	I	€	€	€	€	€	HF
É KÉÁÚT	€	€	€	€	€	€	€	€	€	G	€	G	€	€	€	€	€	G
É KÍ ÁÚT	€	G	€	G	€	G	€	G	€	F	€	F	€	€	€	€	€	í
É KÉÁÚT	€	€	€	€	€	F	F	G	€	F	€	F	€	€	€	€	€	H
É KÍ ÁÚT	€	€	F	F	€	F	G	H	€	€	€	€	€	€	€	€	€	I
V[~]çã	€	G	F	H	€	I	H	Í	€	I	€	I	€	€	€	€	€	FI
Ö!ã áÁV[~]çã	€	FG	í	Fí	€	F€	F€	G€	€	í	€	í	€	€	€	€	€	íí
ç[~]çã&çã	€	í€É	GJÉ	Á	€	í€	í€	Á	€	F€€	€	Á	€	€	€	€	€	Á
V[~]çã	€	GÉ	FFÉ	HÉ	€	G€G	G€G	IIÉ	€	FíÉ	€	FíÉ	€	€	€	€	€	Á

Úcã ÖÁã ^	Úã:ÁUÖç^)^ Ú[~]cã[~]ã				U&ã ÁÖ[~]çãã Y^•cã[~]ã Y^•cã[~]ã				Úã:ÁUÖç^)^ P[~]cã[~]ã				U&ã ÁÖ[~]çãã Y^•cã[~]ã Öã cã[~]ã				Q çã[~]ã	
	Š~c	V@~	Üã @	ç[~]ÉV[~]çã	Š~c	V@~	Üã @	ç[~]ÉV[~]çã	Š~c	V@~	Üã @	ç[~]ÉV[~]çã	Š~c	V@~	Üã @	ç[~]ÉV[~]çã		
Úã ÁP[~]çã	€	2	1	3	€	1	G	H	€	F	€	F	€	€	€	€	€	í
É KÍ ÁÚT	€	2	1	3	€	1	G	H	€	F	€	F	€	€	€	€	€	í
É KÉÁÚT	€	G	F	H	€	F	€	F	€	2	€	2	€	€	€	€	€	í
É KÍ ÁÚT	€	G	F	H	€	F	4	5	€	€	€	€	€	€	€	€	€	8
É KÉÁÚT	€	€	€	€	€	€	€	€	€	G	€	G	€	€	€	€	€	G
V[~]çãK[~]çã	€	í	H	J	€	H	í	J	€	í	€	í	€	€	€	€	€	GH
Á ÁÖ[~]ÉV[~]çã	€	ííÉ	HÉH	Á	€	HÉH	ííÉ	Á	€	F€€	€	Á	€	€	€	€	€	Á
UPØ	€€€	Éí€	Éí€	Éí€	€€€	Éí€	Éíí	Éí€	€€€	ÉG	€€€	ÉG	€€€	€€€	€€€	€€€	€€€	ÉFJ

Ó[~},oAM|ã,ãããQ&É
 UUÁQ,cAFiI
 Ó[!:]ããÖÖÁGii
 QI FÁGii È Ñi

Óã Á -Á[] * Á^ã&@
 ÞEUIKÁJã:ÁU/ÖE^ } ^
 ÖEY KÁU&ã ÁQ[] ^çããÁ Á^•cã[~} á
 Y ^ã&@:KÁU } }

ÖE^ Á ðã ^ KÖÓÓUÜÖY ÚT
 Úã ÁQ[] á^ KÉÉÉÉÉÉÉF
 Úãã ÖÖãã KÁ Þ BDEFG
 Úãã ^ ÁQ[] KÖ

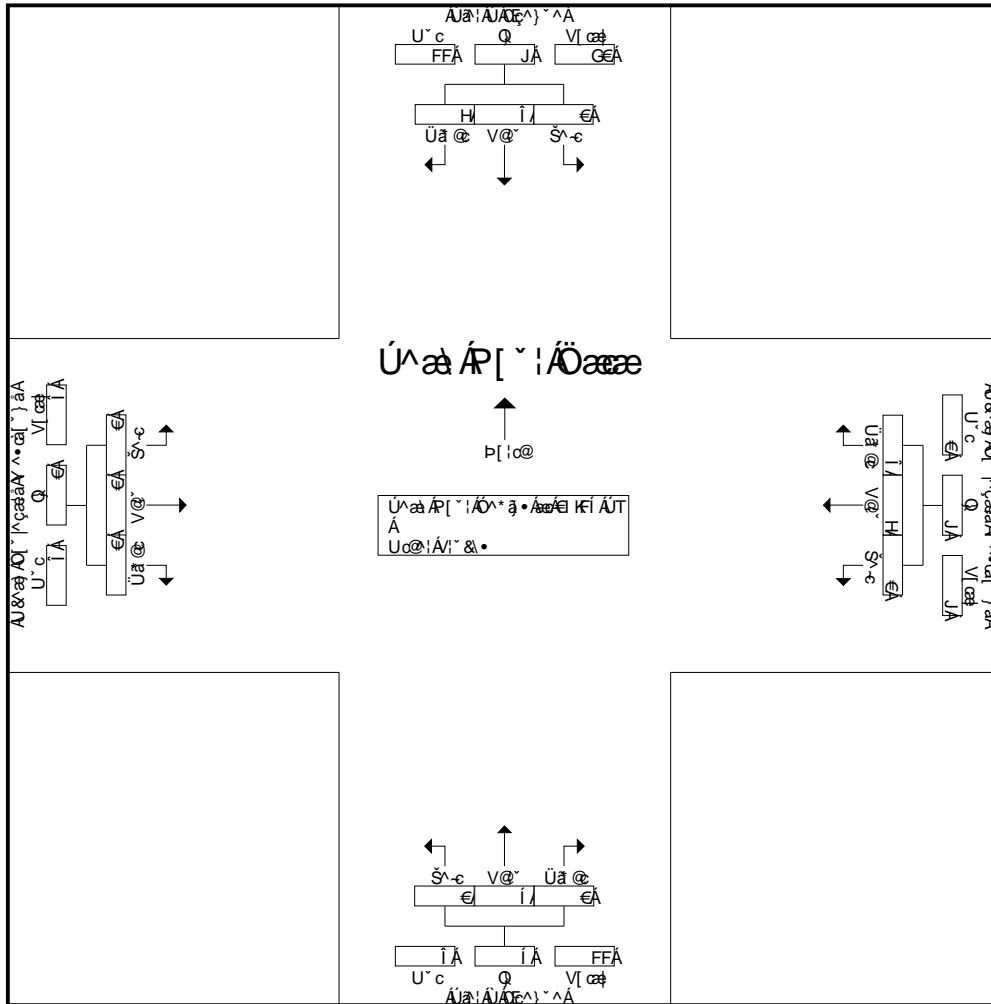

Ú^ã ÁR[~} ! ÖÖãã • Áãã KFI ÁUT Áã Áã KFI ÁUT Áã Áã KFI ÁUT
 Ú^ã ÁR[~} ! Áã Áã ÖÖãã ÖÖãã !:ãã ÖÖãã • Áãã K

	e KFI ÁUT				e KFI ÁUT				e KFI ÁUT				e KFI ÁUT			
ÉÉÁ ã • È	€	2	1	3	€	1	G	H	€	F	€	F	€	€	€	€
ÉFÍ Á ã • È	€	G	F	H	€	F	€	F	€	2	€	2	€	€	€	€
ÉHEÁ ã • È	€	G	F	H	€	F	4	5	€	€	€	€	€	€	€	€
ÉIÍ Á ã • È	€	€	€	€	€	€	€	€	€	G	€	G	€	€	€	€
VI çãK[] ^	€	í	H	J	€	H	í	J	€	í	€	í	€	€	€	€
Á ÁQ[] ÁV çã	€	íí È	HÈH	Á	€	HÈH	íí È	Á	€	FÈÈ	€	Á	€	€	€	€
UÞÖ	ÈÈÈÈ	Èí€	Èí€	Èí€	ÈÈÈÈ	Èí€	Èíí	Èí€	ÈÈÈÈ	ÈíG	ÈÈÈÈ	ÈíG	ÈÈÈÈ	ÈÈÈÈ	ÈÈÈÈ	ÈÈÈÈ

Ō[]•ŌĀIḁāāĀ&Ē
 ŪŪŌĀFIĪ
 Ō[]āŌŌŪGĪĪ
 ŌI FŌGĪĒGĪ

ŌāĀ-Ō[]•ĀŌāā@
 ƆHĪŪŪĀĀ/ŪŌĒ^ ^
 ŌĒY ĪŪŪāſĀ Ō[] ^ſāāŌŌāĀā[] ā
 Y ^ā@ĀĪŪ} } ^

ŌāĀā ^ ĪŌŌŪŪŌŌŌŌŌŌ
 ŪāŌ[] ā ĪŌŌŌŌŌŌŌŌ
 ŪāŌŌā ĪŌŌŌŌŌŌŌŌ
 ŪāĀŌĀ ĪŌŌŌŌŌŌŌŌ

Ō[]•ŪIḁāāĒŪā•^•ſĀĀŌĀ•ŌŌŌāāĀĪ' & •ŌŌŌāāŪĪ'ĀĪ' & •ŌŌŌĀāŌĪ' & •ŌŌŌŌĀŌĪ' & •

	ŪāĀŪŌĒ^ ^ ŪĀŌĀ[] ā			Ū&āſĀ[] ^ſāāŌŌāĀā[] ā Y ^•ā[] ā			Ū&āſĀ[] ^ſāāŌŌāĀā[] ā Ōāā[] ā			QāſĀ[] ā
ŪāŌĀĀ ^	ſ^c	Ūā@	Ō[] ĒV[] ā	V@^	Ūā@	Ō[] ĒV[] ā	ſ^c	V@^	Ō[] ĒV[] ā	QāſĀ[] ā
Ē ĪŌŌŌŌŌ	Ī	€	Ī	€	€	€	Gf	İF	İG	İİ
Ē ĪŌĪŌŌ	J	€	J	€	€	€	G	İF	İİ	İİ
Ē ĪŌŌŌŌ	Ī	€	Ī	€	€	€	Gf	İİ	Jİ	FĒİ
Ē ĪŌĪŌŌ	J	€	J	€	€	€	G	İ€	İİ	JH
V[] ā	HF	€	HF	€	€	€	JH	GfJ	HfG	H H
Ē ĪŌŌŌŌ	FG	€	FG	€	€	€	İ	İ€	İİ	İİ
Ē ĪŌĪŌŌ	FF	€	FF	€	€	€	İ	İ€	İİ	İİ
Ē ĪŌŌŌŌ	Fİ	€	Fİ	€	€	€	İ	İH	İ€	İİ
Ē ĪŌĪŌŌ	FJ	€	FJ	€	€	€	Fİ	İH	İF	FĒ€
V[] ā	İJ	€	İJ	€	€	€	Hİ	GĒİ	G G	HfF
Ō[] āĀ[] ā	J€	€	J€	€	€	€	FgJ	İG	İİİ	İİİ
Ō[] ; & ŌĀ	FĒ€	€	Ā	€	€	Ā	GĒH	İİĒ	Ā	Ā
V[] ā	Fİ	€	Fİ	€	€	€	GĒ	İİ	İİ	
Ūā•^•^•ſĀĀŌĀ•	G	€	G	€	€	€	Jİ	G G	Hİİ	HJG
Ā Ūā•^•^•ſĀĀŌĀ•	G Ē	€	G Ē	€	€	€	İ Ē	İİ	İİ Ē	İ Ē
Ō[] āāĀĪ' & •	FH	€	FH	€	€	€	Fİ	İİ	FĒF	Ffİ
Ā Ō[] āāāĀĪ' & •	Fİ Ē	€	Fİ Ē	€	€	€	FĒĒ	GĒĒ	Fİ Ē	Fİ Ē
ŌāāĀĪ'ĀĪ' & •	H	€	H	€	€	€	İ	F€	Fİ	Fİ
Ā ŌāāĀĪ'ĀĪ' & •	HĒH	€	HĒH	€	€	€	HĒ	GĒ	GĒ	GĒ
Ō[] āāĀĪ' & •	GĒH	€	GĒH	€	€	€	İ	İG	İ€	İH
Ā Ō[] āāĀĪ' & •	G Ē	€	G Ē	€	€	€	İ Ē	JĒ	J	FfĒH
ŪāāĀĪ' & •	G	€	G	€	€	€	İ	Fİ	Gf	İİ
Ā ŪāāĀĪ' & •	G Ē	€	G Ē	€	€	€	İ Ē	HĒH	HĒ	İĒH

	ŪāĀŪŌĒ^ ^ ŪĀŌĀ[] ā			Ū&āſĀ[] ^ſāāŌŌāĀā[] ā Y ^•ā[] ā			Ū&āſĀ[] ^ſāāŌŌāĀā[] ā Ōāā[] ā			QāſĀ[] ā
ŪāŌĀĀ ^	ſ^c	Ūā@	Ō[] ĒV[] ā	V@^	Ūā@	Ō[] ĒV[] ā	ſ^c	V@^	Ō[] ĒV[] ā	QāſĀ[] ā
ŪāāĀĪ'ĀĪ' āāā[] ĀĪ ĪŌĪŌŌ ĀĪ ĀĪ ĪŌŌŌŌ ĀĪŪāāĀĀ-ĀĀ										
ŪāāĀĪ'ĀĪ' ĀĪĪŌĪ) āĀĀĀĀĀĀĀ) ĀĪĀĀĀĀĪŌĪŌĪĪĪŌŌ										
Ē ĪŌĪŌŌ	J	€	J	€	€	€	27	İF	İİ	İİ
Ē ĪŌŌŌŌ	İ	€	İ	€	€	€	Gf	77	98	106
Ē ĪŌĪŌŌ	J	€	J	€	€	€	G	İ€	İİ	JH
Ē ĪŌŌŌŌ	12	€	12	€	€	€	İ	İ€	İİ	İİ
V[] āĀ[] ^	Hİ	€	Hİ	€	€	€	İİ	GĒ	Hfİ	H H
Ā Ō[] ĒV[] ā	FĒ€	€	Ā	€	€	Ā	G Ē	İİ Ē	Ā	Ā
UPŌ	ĒJG	Ē€€	ĒJG	Ē€€	Ē€€	Ē€€	ĒFH	ĒİH	Ē€	ĒHH

Ô[~], ◦ÁM|ã ã^áQ&É
 UUÁÔ[cÁFÍÍ
 Ô[í])ãÖÖãGíí
 QÍFDGíÈGí

Ôã Á-Á[]*Á^ã@
 ÞÐUÁUá:ÁU/Ö^)^
 ÖEY KÁU&ã ÁÖ[]^çãáÁÖã cá[~] á
 Y^ã@:KÁU}}^

Öã Áã ^ KÖÖÓÚWÖÖÖÖ
 Uá:ÁÖ[á^ KÉÉÉÉÉÉÉÉÉ
 ÜçãáÖã KÁBDEFG
 Úã^Á[KÁ

Ö[í]~]•ÁUíã çãáUá•^)*Á:Á^@B^•

ÜçãáVá ^	Uá:ÁU/Ö^)^ U[~]c@[~]á			U&ã ÁÖ[~]^çãáÁÖã cá[~] á Y^•cá[~] á			U&ã ÁÖ[~]^çãáÁÖã cá[~] á Öã cá[~] á			Q çÁV[çã]
	Š^c	Üã @	Ö[] ÈV[çã]	V@~	Üã @	Ö[] ÈV[çã]	Š^c	V@~	Ö[] ÈV[çã]	
èí KÉÁÖE	F	€	F	€	€	€	ÖE	H	ÍÍ	ÍJ
èí KÍ ÁÖE	í	€	í	€	€	€	ÖF	GH	ÍÍ	Í€
èí KÉÁÖE	í	€	í	€	€	€	Fí	ÍF	ÍÍ	ÍH
èí KÍ ÁÖE	F	€	F	€	€	€	Fí	ÍÍ	ÍH	ÍÍ
V[çã]	FH	€	FH	€	€	€	ÍH	Fí€	G H	G Í
èí KÉÁÖE	í	€	í	€	€	€	H	H	ÍF	ÍÍ
èí KÍ ÁÖE	F	€	F	€	€	€	I	G	GJ	H€
èí KÉÁÖE	I	€	I	€	€	€	I	Fí	GF	G
èí KÍ ÁÖE	F	€	F	€	€	€	FF	GG	HH	H
V[çã]	FG	€	FG	€	€	€	GG	FEG	FG	FH
Ö[í]ãÁV[çã]	G	€	G	€	€	€	Jí	G G	H Í	HUG
Ö[]: &@Á	F€€	€	Á	€	€	Á	G È	ÍÍ È	Á	Á
V[çã]Á	Í È	€	Í È	€	€	€	G ÈG	ÍJ È	JH È	

ÜçãáVá ^	Uá:ÁU/Ö^)^ U[~]c@[~] á			U&ã ÁÖ[~]^çãáÁÖã cá[~] á Y^•cá[~] á			U&ã ÁÖ[~]^çãáÁÖã cá[~] á Öã cá[~] á			Q çÁV[çã]
	Š^c	Üã @	Ö[] ÈV[çã]	V@~	Üã @	Ö[] ÈV[çã]	Š^c	V@~	Ö[] ÈV[çã]	
U^ã Á[~]: ÁÖ çã • á ÁÖ[] { Áí KÍ ÁÖE Áí Áí KÉÁÖE ÁU^ã ÁÁ-Á										
U^ã Á[~]: Áí: ÁÖ[] çã ÁÖ çã • ^ã çã } ÁÖ^ã • Áã Áí KÍ ÁÖE										
èí KÍ ÁÖE	6	€	6	€	€	€	21	GH	ÍÍ	Í€
èí KÉÁÖE	í	€	í	€	€	€	Fí	61	78	83
èí KÍ ÁÖE	F	€	F	€	€	€	Fí	ÍÍ	ÍH	ÍÍ
èí KÉÁÖE	í	€	í	€	€	€	H	H	ÍF	ÍÍ
V[çã]K[]^ ^	Fí	€	Fí	€	€	€	ÍÍ	Fí€	GG	G Í
Á ÁÖ[] ÈV[çã]	F€€	€	Á	€	€	Á	G È	ÍÍ ÈG	Á	Á
UPØ	È Í €	È€€	È Í €	È€€	È€€	È€€	È Í Í	È JÍ	È G	È H

Ó[~}•ÁM|ãããQ&É
 UUÁQ]cÁFfI
 Ó[!|]ããÖÖÁGíi
 QI FÁGí È Gí

Óã Á -Á[]*Á^ã@
 ÞÐJÁUã:ÁU/Ö^)^
 ÖEY KÁU&ã ÁQ[]^çããÁÖãã[]ã
 Y^ãã@:KÁU"}}}

Qã Áãã ^ KãÖÓÚWÖÓÓÖF
 Úã ÁQ[]ã^ KãÉÉÉÉÉÉF
 ÚããÖÖãã KãHÞDãEFG
 Úãã^Áã KãG

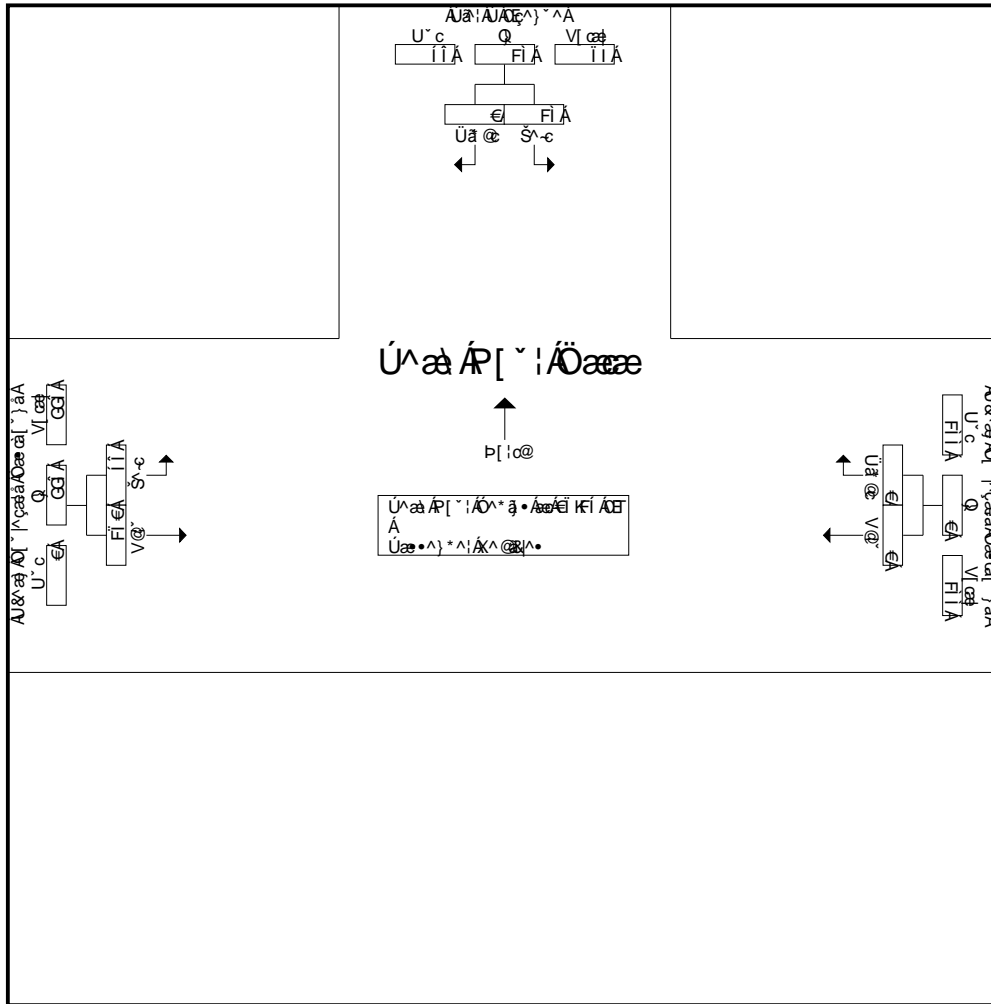

Úãã ÁP[]~!ÖÖããæ •ã ÁQ[]{ ÁEí Kí ÁÖF ÁEí ÁEí KÉÁÖF ÁEÚãã ÁKÁ -ÁF
 Úãã ÁP[]~!Á[]ÖããÖÖ[]!|ããÖÖ^ã•ÁãK

	Eí Kí ÁÖF			Eí Kí ÁÖF			Eí Kí ÁÖF		
EÉÁ ã•È	6	€	6	€	€	€	21	GH	II
ÉFí Á ã•È	í	€	í	€	€	€	Fí	61	78
ÉHÁ ã•È	F	€	F	€	€	€	Fí	íí	íH
Éí Á ã•È	í	€	í	€	€	€	H	H	IF
Vl cããK[]{ ^	Fí	€	Fí	€	€	€	íí	Fí€	Gí
Á ÁÖH]EVL cãã	F€€	€	Á	€	€	€	G È	ííÈ	Á
ÚPØ	Èí€	È€€	Èí€	È€€	È€€	È€€	Èíí	ÈJí	ÈG

Ô[~], ◦ÁM|ã ã^áQ&É
 UUÁÔ cÁFI
 Ô[~] ã^áQ&É
 QI FDI Ë GI

Ôã Á-Á[~] *Á^ã@
 ÞDUÁUá:ÁUÁE^~^
 ÖY KÁU&á Á[~] ^çãáÁÖã cá[~] á
 Y^ã@:KÁ[~]}

ÖY ÁPá ^ KÖÓÓÚWÔÓÓÖF
 Uá:Á[~] á^ KÉÉÉÉÉÉF
 ÜçãáÁÖã cá[~] á KÁBDEFG
 ÜçãáÁÖã cá[~] á KÁ

Ô[~] • ÁUá ç^áÉÖ áçãÁV[~] &•

ÜçãáÁÖã cá[~] á	Uá:ÁUÁE^~^ U[~] çã[~] á			U&á Á[~] ^çãáÁÖã cá[~] á Y^•cá[~] á			U&á Á[~] ^çãáÁÖã cá[~] á Öã cá[~] á			Q çã[~] çã
	Š^c	Üá @	Ö[~] ÉV[~] çã	V@~	Üá @	Ö[~] ÉV[~] çã	Š^c	V@~	Ö[~] ÉV[~] çã	
É KÉÁÖF	F	€	F	€	€	€	F	G	H	I
É KÍ ÁÖF	G	€	G	€	€	€	Í	FH	FJ	GF
É KÉÁÖF	€	€	€	€	€	€	€	J	J	J
É KÍ ÁÖF	G	€	G	€	€	€	H	í	FF	FH
V[~] çã	í	€	í	€	€	€	F€	HG	I G	íí
É KÉÁÖF	F	€	F	€	€	€	F	FH	FI	Fí
É KÍ ÁÖF	F	€	F	€	€	€	€	í	í	í
É KÉÁÖF	€	€	€	€	€	€	€	FH	FH	FH
É KÍ ÁÖF	í	€	í	€	€	€	H	G	G	HH
V[~] çã	í	€	í	€	€	€	I	íí	í J	íí
Ô[~] áÁV[~] çã	FH	€	FH	€	€	€	FI	íí	F€F	FFI
Ö[~] :&@Á	F€€	€	Á	€	€	Á	F€É	ííÉ	Á	Á
V[~] çãÁ	FFÉ	€	FFÉ	€	€	€	FGÉ	ííÉ	ííÉ	

ÜçãáÁÖã cá[~] á	Uá:ÁUÁE^~^ U[~] çã[~] á			U&á Á[~] ^çãáÁÖã cá[~] á Y^•cá[~] á			U&á Á[~] ^çãáÁÖã cá[~] á Öã cá[~] á			Q çã[~] çã
	Š^c	Üá @	Ö[~] ÉV[~] çã	V@~	Üá @	Ö[~] ÉV[~] çã	Š^c	V@~	Ö[~] ÉV[~] çã	
É KÍ ÁÖF	2	€	2	€	€	€	6	13	19	21
É KÉÁÖF	€	€	€	€	€	€	€	J	J	J
É KÍ ÁÖF	G	€	G	€	€	€	H	í	FF	FH
É KÉÁÖF	F	€	F	€	€	€	F	FH	FI	Fí
V[~] çãK[~] { ^	í	€	í	€	€	€	F€	I H	í H	íí
Á Ö[~] ÉV[~] çã	F€€	€	Á	€	€	Á	Fí É	í FÉ	Á	Á
UPØ	É G	É€€	É G	É€€	É€€	É€€	É Fí	É G	É Jí	É J€

Ó[~}•ÁM|ã.ããÁQ&É
 UUÁQ|cÁFíí
 Ó[!|}ãÖÖÁGíí
 QíFÁGíÉGí

Óã Á-Á[]*Á^ã@
 ÞÐJÁUã:ÁU/Ö^)^
 ÖEY KÁU&ã ÁQ[]^çããÁÖãã[]ã
 Y^ãã@:KÁ"}}}

Qã Áãã ^ KÖÓÓUWÖÓÓÖF
 Úã ÁQ[]ã^ KÉÉÉÉÉÉÉF
 ÚããÖÖãã KÁHÞDÉFG
 Úãã^Á[] KÁG

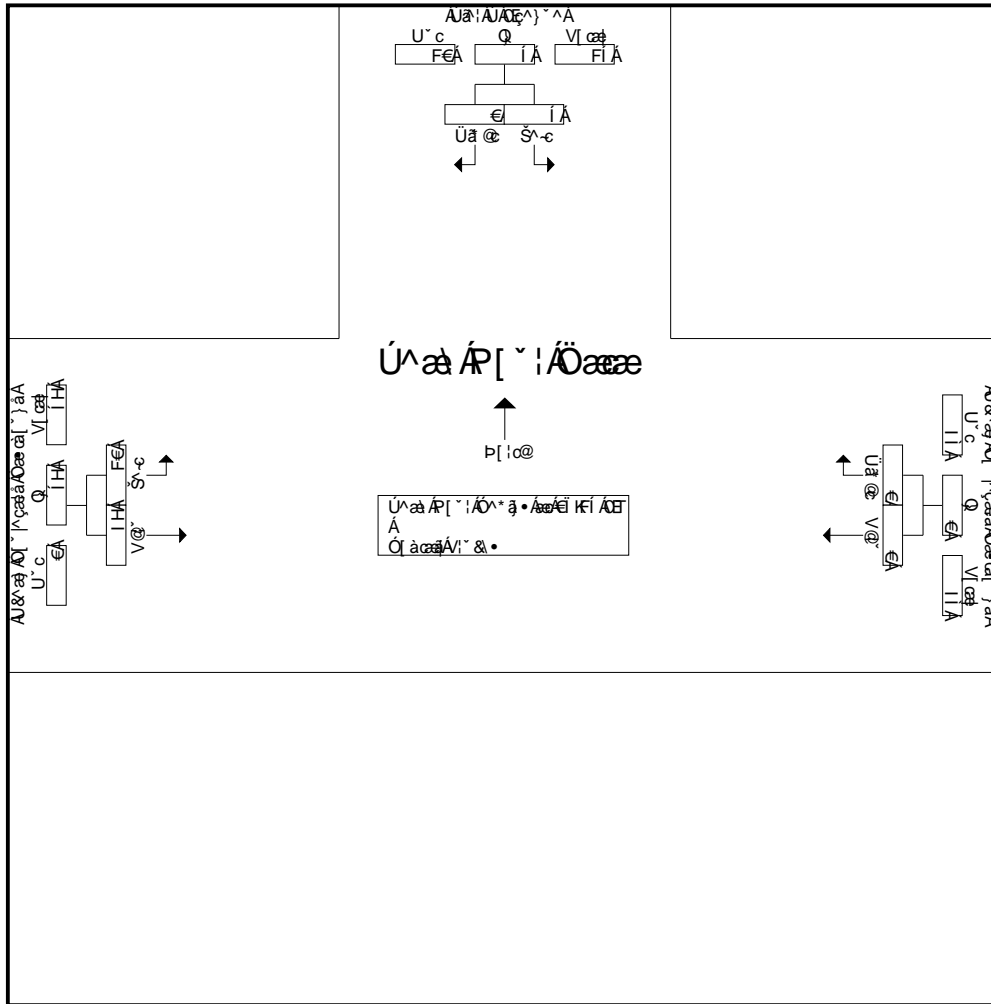

Úãã ÁP[]^!ÖÖããæ •ã ÁQ[] { ÁÉ Kí ÁÖF ÁF ÁÉ KÉÁÖF ÁU^ãã ÁFÁ-ÁF
 Úãã ÁP[]^!Á[]ÖããÖQ[]!|}ãÖÖÁ^ã•ÁãK

	É Kí ÁÖF		É Kí ÁÖF		É Kí ÁÖF		É Kí ÁÖF
ÉÉÁ ã•É	2	€	2	€	€	€	6 13 19
ÉFí Á ã•É	€	€	€	€	€	€	J J
ÉHÁ ã•É	G	€	G	€	€	€	H i FF
Éí Á ã•É	F	€	F	€	€	€	F FH FI
VÍçãK[]{ ^	í	€	í	€	€	€	F€ í H í H
Á ÖH]ÉV]çã	F€€	€	Á	€	€	€	Fí Æ ì FÆ Á
UPØ	È G	È€€	È G	È€€€	È€€€	È€€€	È Fí È G È Jí

Ö[] • ÁV[] ä á ÁQ&É
 UUÁÖ[] cÁFI I
 Ö[] : } aÖÖcÁG I i
 QI FdG i È G I

Öä Á -Á[] * Á^ a&@
 ÞÖUÁÜá: Á/Ö[] ^ ^
 ÖEY KÁU&á Ö[] ^ Çcáá/Öcä[] á
 Y ^ a&@: KÁU } }

Öä Á a& ^ KÖÖÖÜW ÖÖÖÖÖ
 Üá ÁÖ[] á ^ KÖÖÖÖÖÖF
 ÜcäcÖä KÁÖÖÖÖFG
 Ücä ^ Á[] K&

Ö[] • ÁV[] cÁFI Öcä ÁU } Á/ ^ & •

ÜcäcÁ/á ^	Üá: Á/Ö[] ^ ^ Ü[] cÖ[] ^ á			U&á Ö[] ^ Çcáá/Öcä[] á Y ^ • cä[] á			U&á Ö[] ^ Çcáá/Öcä[] á Öcä cä[] á			Q cÄV[] c&
	Š^c	Üä @	Ö[] ÈV[] c&	V@~	Üä @	Ö[] ÈV[] c&	Š^c	V@~	Ö[] ÈV[] c&	
€ KÖÖÖÖ	€	€	€	€	€	€	€	€	€	€
€ KÍ ÁÖ	€	€	€	€	€	€	€	€	€	€
€ KÖÖÖÖ	G	€	G	€	€	€	F	€	F	H
€ KÍ ÁÖ	€	€	€	€	€	€	H	€	H	H
V[] c&	G	€	G	€	€	€	I	€	I	I
€ KÖÖÖÖ	€	€	€	€	€	€	€	F	F	F
€ KÍ ÁÖ	F	€	F	€	€	€	€	F	F	G
€ KÖÖÖÖ	€	€	€	€	€	€	€	I	I	I
€ KÍ ÁÖ	€	€	€	€	€	€	F	I	I	I
V[] c&	F	€	F	€	€	€	F	F€	FF	FG
Ö[] á ÁV[] c&	H	€	H	€	€	€	í	F€	Fí	Fí
Ö[] : & @ Á	F€€	€	Á	€	€	Á	HÈH	ííÈ	Á	Á
V[] c& Á	Fí È	€	Fí È	€	€	€	G È	ííÈ	ì HÈ	

ÜcäcÁ/á ^	Üá: Á/Ö[] ^ ^ Ü[] cÖ[] ^ á			U&á Ö[] ^ Çcáá/Öcä[] á Y ^ • cä[] á			U&á Ö[] ^ Çcáá/Öcä[] á Öcä cä[] á			Q cÄV[] c&
	Š^c	Üä @	Ö[] ÈV[] c&	V@~	Üä @	Ö[] ÈV[] c&	Š^c	V@~	Ö[] ÈV[] c&	
U^ ä Á[] : ÁÖ[] á ÁÖ[] { ÁÖ[] KÍ ÁÖ ÁÖ[] KÖÖÖÖ ÁU^ ä ÁÁ - Á										
U^ ä Á[] : ÁÖ[] cÁ ÁÖ[] • ^ & @ } ÁÖ[] á • ÁÖ[] KÍ ÁÖ										
€ KÍ ÁÖ	€	€	€	€	€	€	€	€	€	€
€ KÖÖÖÖ	2	€	2	€	€	€	F	€	F	3
€ KÍ ÁÖ	€	€	€	€	€	€	3	€	3	H
€ KÖÖÖÖ	€	€	€	€	€	€	€	1	F	F
V[] c& Á[] ^	G	€	G	€	€	€	I	F	I	I
Á Ö[] ÈV[] c&	F€€	€	Á	€	€	Á	ì€	G€	Á	Á
UP Ø	Èì €	È€€	Èì €	È€€	È€€	È€€	ÈHH	Èì €	È Fí	È I H

Ó[] * ÁM |ã ãá Q&E
 UU/ Q c A FFI
 Ó[] } ãÖÖA G I i
 QI F D G i E d i

Óã Á -Á[] * Á^ã@
 ÞEY KÁU&ã ÁU/ Q E ^ ^
 ÖEY KÁU&ã ÁU[] ^ çãá ÁÖã ã [^] á
 Y ^ã@ : KÁU } }

Qã Á çã ^ K S Ö Ó Ú W Ö Ö Ó Ö F
 Úã Á Ö[] á ^ K E E E E E E E F
 Úã Ö Ö Öã ^ K Á H B D E F G
 Úã ^ Á [] K G

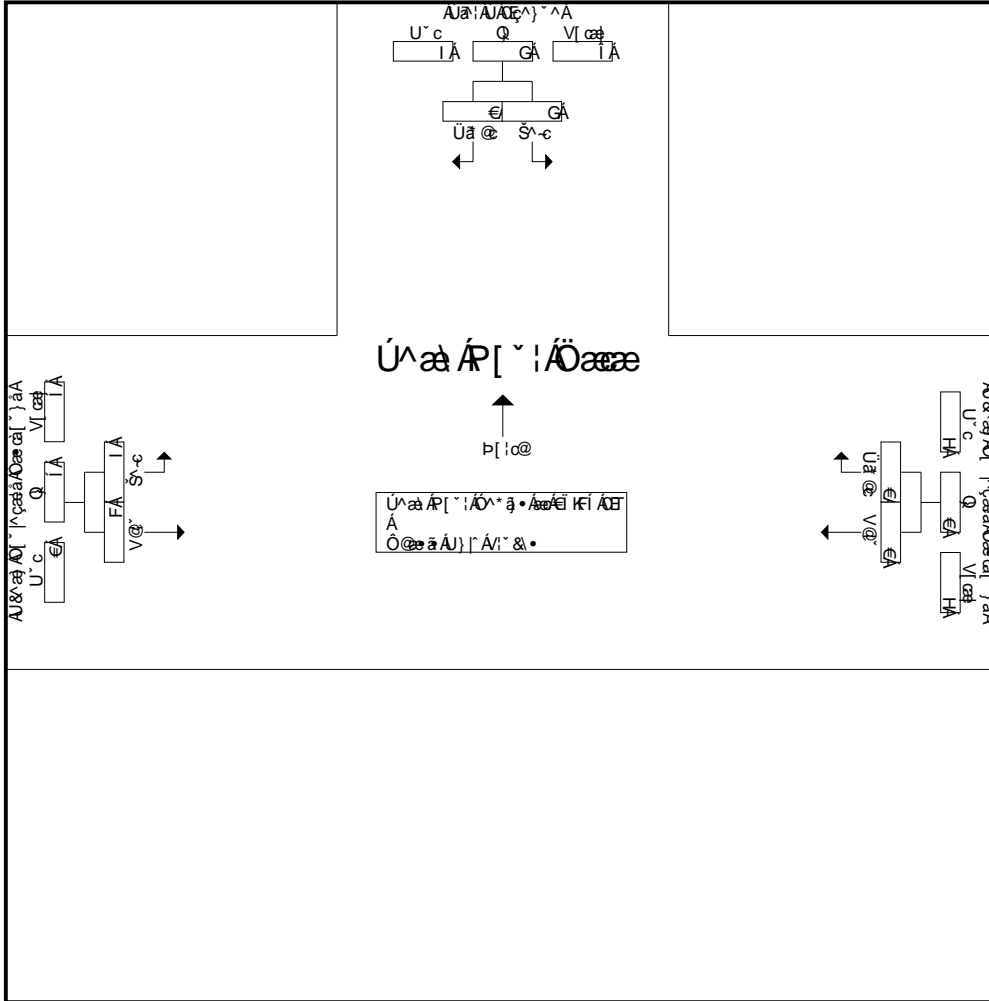

Úã Á R[^] Á Öãææ * Á Ö [] (Á Ö KFI Á Ö F Á Ö F K E Ö Ö F Á Ö Úã Á R[^] Á Öãææ
 Úã Á R[^] Á Öãææ [] } ã Ö Ö A G I i * Á Ö K

	€ KFI Á Ö F	€	€	€	€ KFI Á Ö F	€	€	€	€ KFI Á Ö F	€	€	€
ÉÉÁ ä • É	€	€	€	€	€	€	€	€	€	€	€	€
ÉFI Á ä • É	2	€	€	2	€	€	€	€	F	€	€	F
ÉHEÁ ä • É	€	€	€	€	€	€	€	€	3	€	€	3
ÉI Á ä • É	€	€	€	€	€	€	€	€	1	€	€	F
VI çã K I] ^	G	€	G	€	€	€	€	€	I	F	€	I
Á Ö F] E V] çã	F € €	€	Á	€	€	€	€	Á	ì €	Ö €	€	Á
Ú P Ø	€ € €	€ € €	€ € €	€ € €	€ € €	€ € €	€ € €	€ € €	È H H	€ € €	€ € €	È F I

Ö[] • ÁV[] ä á ÁQ&E
 UUÁÖ[] cÁFI
 Ö[] : } aÖÖcÁGíi
 QI FDG i È G i

Öä Á -Á[] * Á^ ä@
 ÞHUKÁ:Á/Ö[] ^ ^
 ÖY KÁ&á Ö[] ^ ÇcááÁÖc á[] á
 Y ^ ä@:KÁ[] }

Öä Á ä ^ KÖÖÓÚWÖÖÖÖ
 Üä ÁÖ[] á^ KÖÖÖÖÖÖF
 ÜcááÖä KÁHÖÖÖFG
 Ücá^ Á[] KÁ

Ö[] • ÁV[] ä á ÁQ&E[] cÁFI[] &•

ÜcááÁ/á ^	Üä:Á/Ö[] ^ ^ Ü[] cÁ[] á			U&á Ö[] ^ ÇcááÁÖc á[] á Y ^ • cÁ[] á			U&á Ö[] ^ ÇcááÁÖc á[] á Öc á[] á			Q cÁ[] cÁ
	Š^c	Üä @	Ö[] ÈV[] cÁ	V@~	Üä @	Ö[] ÈV[] cÁ	Š^c	V@~	Ö[] ÈV[] cÁ	
èi KÖÖÖ	G	€	G	€	€	€	€	F	F	H
èi KÍ ÁÖ	F	€	F	€	€	€	€	H	H	I
èi KÖÖÖ	F	€	F	€	€	€	G	î	î	J
èi KÍ ÁÖ	G	€	G	€	€	€	G	F	H	í
V[] cÁ	î	€	î	€	€	€	I	FF	FÍ	GF
èi KÖÖÖ	H	€	H	€	€	€	F	î	î	FÈ
èi KÍ ÁÖ	F	€	F	€	€	€	€	î	î	î
èi KÖÖÖ	î	€	î	€	€	€	H	î	FF	FÍ
èi KÍ ÁÖ	î	€	î	€	€	€	€	FF	FF	FÍ
V[] cÁ	FÍ	€	FÍ	€	€	€	I	HF	HÍ	íG
Ö[] ä ÁV[] cÁ	GH	€	GH	€	€	€	ì	IG	í€	îH
Ö[] :&@Á	F€€	€	Á	€	€	Á	FÍ	ìI	Á	Á
V[] cÁÁ	HÈÈ	€	HÈÈ	€	€	€	FF	íIÈ	íIÈ	

ÜcááÁ/á ^	Üä:Á/Ö[] ^ ^ Ü[] cÁ[] á			U&á Ö[] ^ ÇcááÁÖc á[] á Y ^ • cÁ[] á			U&á Ö[] ^ ÇcááÁÖc á[] á Öc á[] á			Q cÁ[] cÁ
	Š^c	Üä @	Ö[] ÈV[] cÁ	V@~	Üä @	Ö[] ÈV[] cÁ	Š^c	V@~	Ö[] ÈV[] cÁ	
èi KÍ ÁÖ	F	€	F	€	€	€	€	H	H	I
èi KÖÖÖ	F	€	F	€	€	€	2	6	8	J
èi KÍ ÁÖ	G	€	G	€	€	€	G	F	H	í
èi KÖÖÖ	3	€	3	€	€	€	F	î	î	10
V[] cÁ[] ^	î	€	î	€	€	€	í	FÍ	GF	G
Á Ö[] ÈV[] cÁ	F€€	€	Á	€	€	Á	GÈÈ	íIÈG	Á	Á
UPØ	ÈìH	È€€	ÈìH	È€€	È€€	È€€	ÈG	ÈíI	ÈíI	È€€

Ô[~ } , o ÁM | a , a a Q & E
 UU A Q c A F F I
 Ô[! |] a a Q A G I i
 Q I F D G i E d i

Ôa: Á - Á[] * Á ^ a a @
 P B U K A J a : A U / C E ^ ~ ^
 O E Y K A U & a j A Q [~ ^ ç a a Á O a e a [~] á
 Y ^ a a @ : K A U } } ~

Q a ^ A a j ^ K a S O O U W O O O C E F
 U a r A Q [á ^ K e e e e e e e F
 U a s o Á O a e ^ K a H B D E F G
 Ú a e ^ Á r [K a G

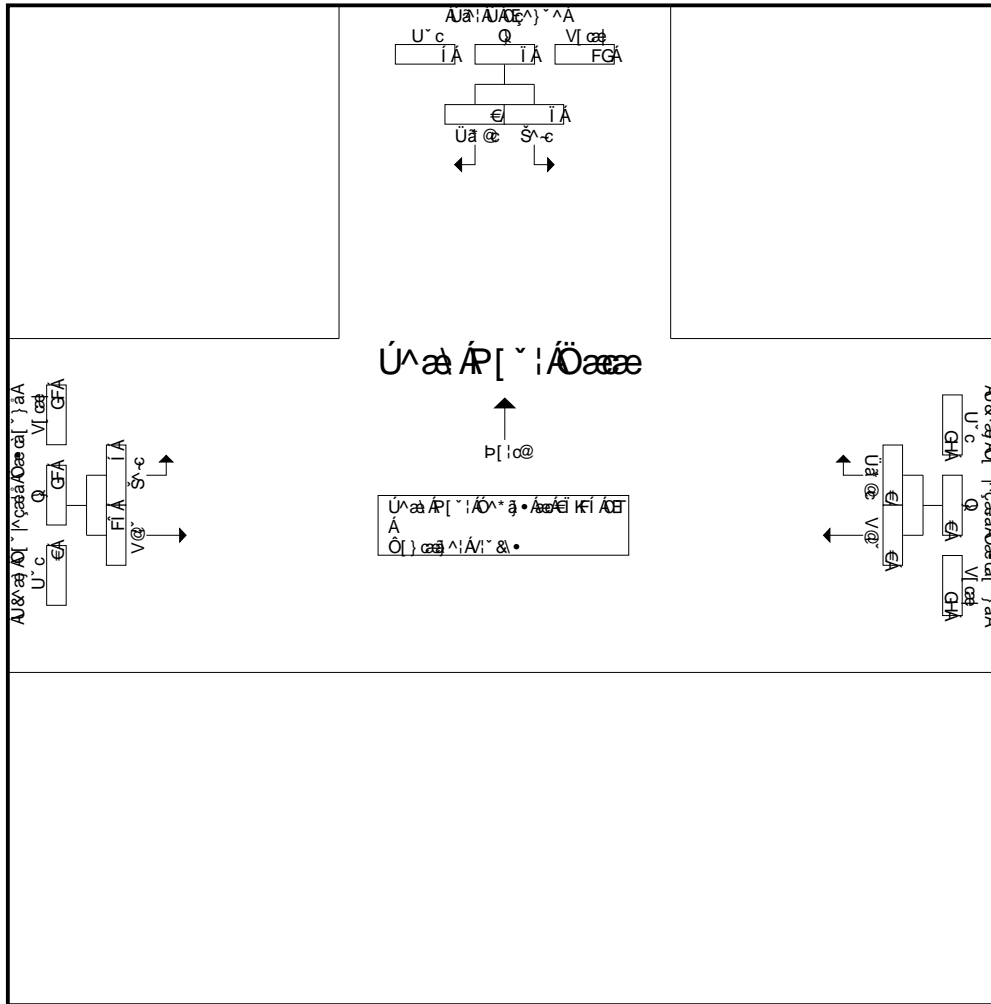

Ú ^ a a Á R [~ ! Á Ö a a j a a A e K I K I Á C E F
 Ú ^ a a Á R [~ ! Á Ö a a Q I] ! a a @ Á ^ a a K

	€ I K I Á C E F			€ I K I Á C E F			€ I K I Á C E F		
É e Á a • È	F	€	F	€	€	€	€	H	H
É F I Á a • È	F	€	F	€	€	€	2	6	8
É H e Á a • È	G	€	G	€	€	€	G	F	H
É i Á a • È	3	€	3	€	€	€	F	i	i
V I ç a K I] { ^	i	€	i	€	€	€	i	F I	G F
Á Á C H] E V] ç a	F e e	€	Á	€	€	Á	G H	i i E	Á
U P Ø	È i H	È e e e	È i H	È e e e	È e e e	È e e e	È E G	È i i	È i i

Ö[] • ÁV[] ä á ÁQ&É
 UUÁÖ[] cÁFI I
 Ö[] : } aÖÖcÁG I i
 QI FDG i È G I

Öä Á -Á[] * Á^ aä@
 ÞEUIÁUä: ÁUÁÖ[] ^ ^
 ÖEY KÁU& aä ÁÖ[] ^ cä aÁÖä cä[] á
 Y ^ aä@: KÁU } }

Öä Á aä ^ KÖÖÖÜW ÖÖÖÖE
 Uä: ÁÖ[] á^ KÖÖÖÖÖE
 Uä aÖä KÁEÞEFG
 Uä ^ Á: KÁ

Öi[] • ÁUä c ä EÜ c@: Á/ I' & •

Uä: ÁUÁÖ[] ^ ^ U[] c@ [] á	Uä: ÁUÁÖ[] ^ ^ U[] c@ [] á			U& aä ÁÖ[] ^ cä aÁÖä cä[] á Y ^ • cä[] á			U& aä ÁÖ[] ^ cä aÁÖä cä[] á Öä cä[] á			Q cÄV[] cä
	Š^ c	Üä @	Ö[] ÈV[] cä	V@	Üä @	Ö[] ÈV[] cä	Š^ c	V@	Ö[] ÈV[] cä	
Uä: ÁUÁÖ[] ^ ^	Š^ c	Üä @	Ö[] ÈV[] cä	V@	Üä @	Ö[] ÈV[] cä	Š^ c	V@	Ö[] ÈV[] cä	Q cÄV[] cä
È KÖÖÖE	F	€	F	€	€	€	€	€	€	F
È KÍ ÁÖE	€	€	€	€	€	€	€	G	G	G
È KÖÖÖE	€	€	€	€	€	€	F	F	G	G
È KÍ ÁÖE	I	€	I	€	€	€	F	H	I	I
V[] cä	I	€	I	€	€	€	G	I	I	FH
È KÖÖÖE	G	€	G	€	€	€	€	G	G	I
È KÍ ÁÖE	I	€	I	€	€	€	G	H	I	FG
È KÖÖÖE	I	€	I	€	€	€	€	F	F	I
È KÍ ÁÖE	I	€	I	€	€	€	H	G	I	FF
V[] cä	GF	€	GF	€	€	€	I	I	FH	H
Ö[] aÁV[] cä	G	€	G	€	€	€	I	FI	GF	I I
Ö[] : & @	F€€	€	Á	€	€	Á	HÈH	I I È	Á	Á
V[] cä	I I ÈH	€	I I ÈH	€	€	€	FI È	GJ È	I I È	

Uä: ÁUÁÖ[] ^ ^ U[] c@ [] á	Uä: ÁUÁÖ[] ^ ^ U[] c@ [] á			U& aä ÁÖ[] ^ cä aÁÖä cä[] á Y ^ • cä[] á			U& aä ÁÖ[] ^ cä aÁÖä cä[] á Öä cä[] á			Q cÄV[] cä
	Š^ c	Üä @	Ö[] ÈV[] cä	V@	Üä @	Ö[] ÈV[] cä	Š^ c	V@	Ö[] ÈV[] cä	
Uä: ÁUÁÖ[] ^ ^	Š^ c	Üä @	Ö[] ÈV[] cä	V@	Üä @	Ö[] ÈV[] cä	Š^ c	V@	Ö[] ÈV[] cä	Q cÄV[] cä
Uä: ÁUÁÖ[] ^ ^	Š^ c	Üä @	Ö[] ÈV[] cä	V@	Üä @	Ö[] ÈV[] cä	Š^ c	V@	Ö[] ÈV[] cä	Q cÄV[] cä
È KÍ ÁÖE	€	€	€	€	€	€	€	G	G	G
È KÖÖÖE	€	€	€	€	€	€	1	F	G	G
È KÍ ÁÖE	4	€	4	€	€	€	F	3	4	8
È KÖÖÖE	G	€	G	€	€	€	€	G	G	I
V[] cä [] ^	I	€	I	€	€	€	G	I	F€	FI
Á Ö[] ÈV[] cä	F€€	€	Á	€	€	Á	G€	I €	Á	Á
UPØ	È I I	È€€	È I I	È€€	È€€	È€€	È €€	È I I	È G	È €€

Ó[~}•ÁM|ã.ããÁQ&É
 UUÁQ|cÁFíí
 Ó[!|]ããÖÖÁGíí
 QíFÁGíÉGí

Óã Á-Á[]*Á^ã&@
 ÞÉUÁUã:ÁU/Ö^)^
 ÖEY KÁU&ã ÁQ[]^çããÁÖãã[]ã
 Y^ã&@:KÁU"}}}

Qã Áãã ^ KÖÖÓÚWÖÖÓÖE
 Úã ÁQ[]ã^ KÉÉÉÉÉÉÉÉÉÉ
 ÚããÖÖãã KÁÉÉÉÉÉÉÉÉÉÉ
 Úãã^Áã KÁG

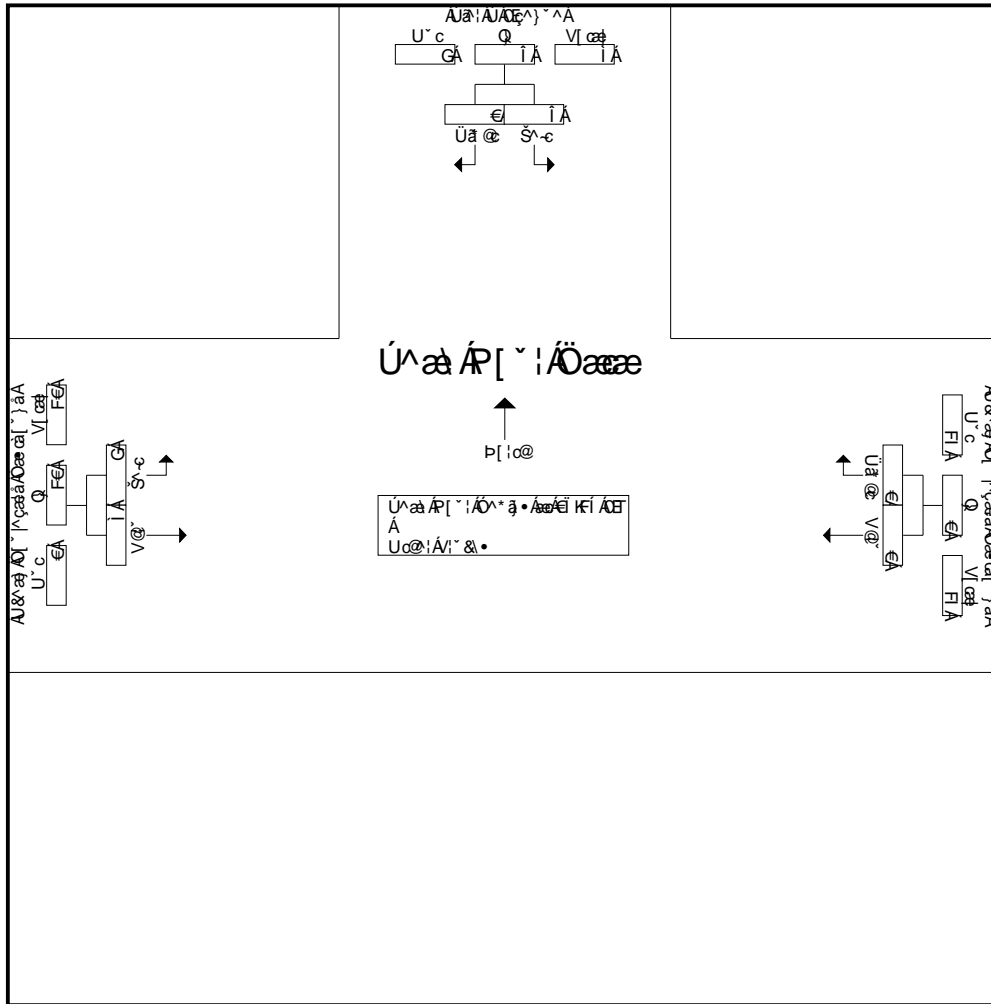

Úãã ÁP[]^!ÁÖããæ •ã ÁQ[] { ÁÉ Kí ÁÖE ÁÉ ÁÉ KÉÁÖE ÁÉ Úãã ÁKÁ-ÁK
 Úãã ÁP[]^!ÁÖããæ Qí!|]ããÖÖÁ^ã•ÁãK

	€ Kí ÁÖE	€	€	€	€ Kí ÁÖE	€	€	€	€ Kí ÁÖE	€	G	G
ÉÉÁ ã•É	€	€	€	€	€	€	€	€	€	€	G	G
ÉFí Á ã•É	€	€	€	€	€	€	€	€	1	F	F	G
ÉHÉÁ ã•É	4	€	€	4	€	€	€	€	F	3	3	4
Éí Á ã•É	G	€	€	G	€	€	€	€	€	G	G	G
VÍ çãKí] { ^	í	€	€	í	€	€	€	€	G	í	í	FÉ
Á ÁÖE] ÉV] çã	F€€	€	€	Á	€	€	€	Á	Ö€	í €	í €	Á
UPØ	ÉÉí	ÉÉ€	ÉÉí	ÉÉí	ÉÉ€	ÉÉ€	ÉÉ€	ÉÉ€	ÉÉ€	ÉÉí	ÉÉí	ÉÉG

Ó[~]·ÁV|ā ā·ÁQ&É
 UUÁQ cÁFI I
 Ó[~]·ÁV|ā ā·ÁQ&É
 QI FDI È GI

Ó[~]·ÁV|ā ā·ÁQ&É
 UUÁQ cÁFI I
 Ó[~]·ÁV|ā ā·ÁQ&É
 Y^æ@:KÁ}}^

Ó[~]·ÁV|ā ā·ÁQ&É
 UUÁQ cÁFI I
 Ó[~]·ÁV|ā ā·ÁQ&É
 Uæ^Á[K&

Ó[~]·ÁV|ā ā·ÁQ&É
 UUÁQ cÁFI I
 Ó[~]·ÁV|ā ā·ÁQ&É
 Y^æ@:KÁ}}^

Úæ·ÁV ā ā·ÁQ&É Ú[~]·ÁV ā ā·ÁQ&É	Ú[~]·ÁV ā ā·ÁQ&É Ú[~]·ÁV ā ā·ÁQ&É			U&æ ÁQ[~]·ÁV ā ā·ÁQ&É Y^æ@:KÁ}}^			U&æ ÁQ[~]·ÁV ā ā·ÁQ&É Ú[~]·ÁV ā ā·ÁQ&É			Q cÁFI I
	Š^c	Úā @	Q[~] ÈV cæ	V@~	Úā @	Q[~] ÈV cæ	Š^c	V@~	Q[~] ÈV cæ	
ÈKÈÁÚT	Fì	€	Fì	€	€	€	Fì	ÌJ	ÌH	JÈ
ÈKÌ ÁÚT	H	€	H	€	€	€	FG	ÌJ	ÌF	FFÌ
ÈKÈÁÚT	GH	€	GH	€	€	€	Fì	JG	Fèí	FHE
ÈKÌ ÁÚT	GF	€	GF	€	€	€	Fì	JÌ	FFÌ	FHÌ
V cæ	JÌ	€	JÌ	€	€	€	ÌJ	HÌ	HÌ	ÌÌF
ÈKÈÁÚT	Fì	€	Fì	€	€	€	FJ	Fèí	FQ	FìH
ÈKÌ ÁÚT	GG	€	GG	€	€	€	FG	JF	FèH	FQ
ÈKÈÁÚT	HG	€	HG	€	€	€	J	Fèí	FFÌ	Fì
ÈKÌ ÁÚT	ÌÌ	€	ÌÌ	€	€	€	Ì	JÌ	Fèí	FìG
V cæ	FFJ	€	FFJ	€	€	€	ÌÌ	ÌÈG	ÌÌJ	ÌÌÌ
Ó[~]·ÁV ā ā·ÁQ&É Q[~]·ÁV ā ā·ÁQ&É V cæ	GFI	€	GFI	€	€	€	Fèí	ÌFJ	ÌG	FèH
	FèÈ	€	Á	€	€	Á	FQÈ	ÌÌÈG	Á	Á
	GÈÈ	€	GÈÈ	€	€	€	FèÈG	ÌJÈG	ÌJÈ	
Úæ·ÁV ā ā·ÁQ&É Á Úæ·ÁV ā ā·ÁQ&É	ÌF	€	ÌF	€	€	€	ÌÌ	GÌ	GÌ	Hèí
	FJÈG	€	FJÈG	€	€	€	ÌÈÈ	HÈÈ	HG	GJÈ
Ó[~]·ÁV ā ā·ÁQ&É Á Úæ·ÁV ā ā·ÁQ&É	ÌH	€	ÌH	€	€	€	G	GÈH	GJ	HG
	HÈÈ	€	HÈÈ	€	€	€	GÈÈ	HÈÈ	HÈÈ	HÈÈ
Ó[~]·ÁV ā ā·ÁQ&É Á Úæ·ÁV ā ā·ÁQ&É	J	€	J	€	€	€	Fì	ÌF	ÌÌ	ÌÌ
	ÌÈG	€	ÌÈG	€	€	€	FÈG	ÌÈÈ	ÌÈÈ	ÌÈÈ
Ó[~]·ÁV ā ā·ÁQ&É Á Úæ·ÁV ā ā·ÁQ&É	H	€	H	€	€	€	FF	GFG	GGH	GÌ
	FìÈÈ	€	FìÈÈ	€	€	€	FèÈÈ	GJÈÈ	G	GÈÈ
Uc@:ÁV ā ā·ÁQ&É Á Úæ·ÁV ā ā·ÁQ&É	ÌÌ	€	ÌÌ	€	€	€	J	Fì	G	ÌF
	GG	€	GG	€	€	€	ÌÈÈ	GÈÈ	GÈÈ	ÌÈÈ

Úæ·ÁV ā ā·ÁQ&É Ú[~]·ÁV ā ā·ÁQ&É	Ú[~]·ÁV ā ā·ÁQ&É Ú[~]·ÁV ā ā·ÁQ&É			U&æ ÁQ[~]·ÁV ā ā·ÁQ&É Y^æ@:KÁ}}^			U&æ ÁQ[~]·ÁV ā ā·ÁQ&É Ú[~]·ÁV ā ā·ÁQ&É			Q cÁFI I
	Š^c	Úā @	Q[~] ÈV cæ	V@~	Úā @	Q[~] ÈV cæ	Š^c	V@~	Q[~] ÈV cæ	
ÈKÈÁÚT	Fì	€	Fì	€	€	€	19	Fèí	125	FìH
ÈKÌ ÁÚT	GG	€	GG	€	€	€	FG	JF	FèH	FQ
ÈKÈÁÚT	HG	€	HG	€	€	€	J	107	FFÌ	Fì
ÈKÌ ÁÚT	47	€	47	€	€	€	Ì	JÌ	Fèí	152
V cæ	FFJ	€	FFJ	€	€	€	ÌÌ	ÌÈG	ÌÌJ	ÌÌÌ
Á Úæ·ÁV ā ā·ÁQ&É UPØ	FèÈÈ	€	Á	€	€	Á	FèÈÈ	ÌJÈÈ	Á	Á
	ÈÈÈÈ	€	ÈÈÈÈ	€	€	€	ÈÈÈÈ	ÈÈÈÈ	ÈÈÈÈ	ÈÈÈÈ

Ó[~}•ÁM|ãããÁQ&É
 UUÁQ|cÁFFÍ
 Ó[!|}ããÖÖÁVÍ
 Q|FÁG|ÈG|

Óã Á-Á[~}•ÁQã@
 ÞEJKAJã:ÁUÁE^}•^
 ÖEY KÁU&ã ÁQ|~|cãããÁÖããã[~}ã
 Y^ãã@:KÁU}}•

Qã Áãã ^ KÖÖÓÓUΩÓÓÓ Ö
 Úã ÁQ|ã^ KÉÉÉÉÉÉÉÉÉÉ
 ÚããÖÖãã KÁHÞEFG
 Úã^ÁP| KÁG

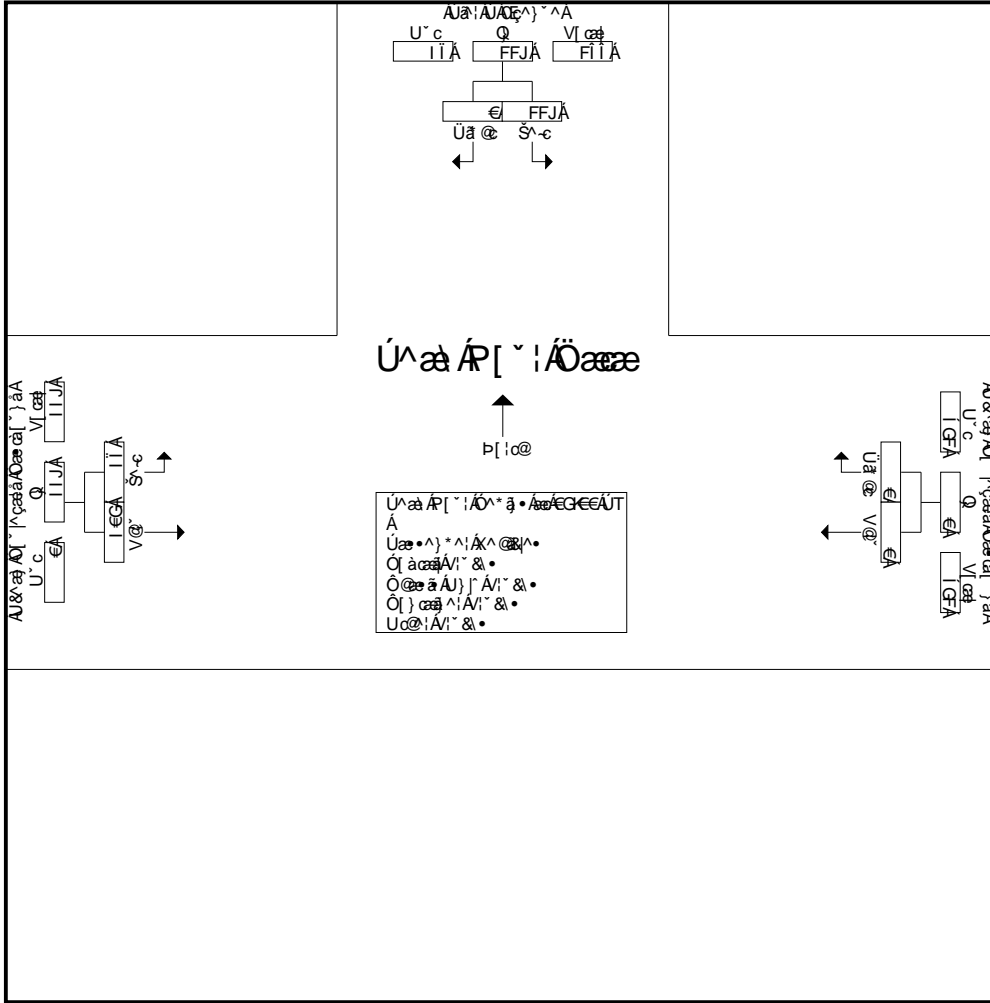

Úãã ÁP[~}!ÁQãããã ÁQ|{ ÁEGEÁÚ Á ÁEGKÍ ÁÚ ÁÚ Úãã Á Á Á
 Úãã ÁP[~}!Á ÁÖãã@|!|ããÖÖ^ãã ÁÁK

	EGEÁÚ			EGEÁÚ			EGEÁÚ		
ÉÉÁ ã•È	FÌ	€	FÌ	€	€	€	19	Fé	125
ÉFÍ Á ã•È	GG	€	GG	€	€	€	FG	JF	FÉH
ÉHEÁ ã•È	HG	€	HG	€	€	€	J	107	FFÍ
ÉÍ Á ã•È	47	€	47	€	€	€	í	Jì	Fé
V cãK ~} { ^	FFJ	€	FFJ	€	€	€	IÍ	I€G	I I J
Á ÁH ÈV cã	FEE	€	Á	€	€	€	FEE	ì JÈ	Á
ÚPØ	È HH	ÈÈÈÈ	È HH	ÈÈÈÈ	ÈÈÈÈ	ÈÈÈÈ	È È FÌ	ÈHU	È JÌ

Ô[~], ◦ÁM|ã ã^áQ&É
 UUÁÔ cÁFIÍ
 Ô[~] ã^áQ&É
 QI FDI Ë GI

Ôã Á-Á[~] *Á^ã@
 ÞEYKÁU&á Á[~] Á^ã@
 ÔEY KÁU&á Á[~] Á^ã@
 Y^ã@:KÁU}}

Ôã Á-Á[~] *Á^ã@
 ÞEYKÁU&á Á[~] Á^ã@
 ÔEY KÁU&á Á[~] Á^ã@
 Y^ã@:KÁU}}

Ô[~] • ÁUã çãÁUã • Á^ã@

ÙçãÁ/ã ^	Úã:ÁUã^ ^ Ú[~] çã[~] á			U&ã Á[~] Á^ã@ Y^ã@			U&ã Á[~] Á^ã@ çã[~] á			Q çã[~] çã
	Š^c	Üã @	Ö[~] ÈV[~] çã	V@~	Üã @	Ö[~] ÈV[~] çã	Š^c	V@~	Ö[~] ÈV[~] çã	
ÈKÈÁÚT	I	€	I	€	€	€	J	G	HH	H
ÈKÍ ÁÚT	H	€	H	€	€	€	Í	G	HH	H
ÈKÈÁÚT	H	€	H	€	€	€	í	GG	HÈ	HH
ÈKÍ ÁÚT	I	€	I	€	€	€	í	GH	GJ	HH
V[~] çã	FI	€	FI	€	€	€	G	JÍ	FG	FHU
ÈKÈÁÚT	î	€	î	€	€	€	î	G	H	I €
ÈKÍ ÁÚT	F	€	F	€	€	€	í	HF	H	H
ÈKÈÁÚT	J	€	J	€	€	€	H	HÈ	HH	I G
ÈKÍ ÁÚT	FF	€	FF	€	€	€	I	HG	H	I I
V[~] çã	G	€	G	€	€	€	FI	FGF	FHU	FI I
Ô[~] áÁV[~] çã	I F	€	I F	€	€	€	I I	GÍ	G I	HÉ
Ö[~] :&@	F€€	€	Á	€	€	€	FÍ È	ì GÈ	Á	Á
V[~] çã	FHÈ	€	FHÈ	€	€	€	FÍ È	ì FÈ	ì I È	

ÙçãÁ/ã ^	Úã:ÁUã^ ^ Ú[~] çã[~] á			U&ã Á[~] Á^ã@ Y^ã@			U&ã Á[~] Á^ã@ çã[~] á			Q çã[~] çã
	Š^c	Üã @	Ö[~] ÈV[~] çã	V@~	Üã @	Ö[~] ÈV[~] çã	Š^c	V@~	Ö[~] ÈV[~] çã	
ÈKÈÁÚT	I	€	î	€	€	€	6	G	H	I €
ÈKÍ ÁÚT	F	€	F	€	€	€	í	HF	36	H
ÈKÈÁÚT	J	€	J	€	€	€	H	HÈ	HH	I G
ÈKÍ ÁÚT	11	€	11	€	€	€	I	32	H	47
V[~] çã	G	€	G	€	€	€	FI	FGF	FHU	FI I
Á Ö[~] ÈV[~] çã	F€€	€	Á	€	€	€	FGÈ	ì I È	Á	Á
UPØ	È FI	È€€	È FI	È€€	È€€	È€€	È I €	È I I	È I I	È I H

Ó[~}•ÁM|ãããQ&E
 UUÁQ|cÁFII
 Ó[!|}ããÖÁGII
 Q|FÁG|EÁI

Óã Á-Á[]*Á^ã@
 ÞHUA:AU/CE^)^
 ÖEY KA&ã ÁQ| ^çããÁÖãã[~]ã
 Y^ãã@:KAU}}^

Qã Áãã ^ KÖÓÓUW ÖÖÓT Ö
 Uã ÁQ| á^ KEEEEEEF
 UããÖÁãã KÁHDEFG
 Uãã^Áã KAG

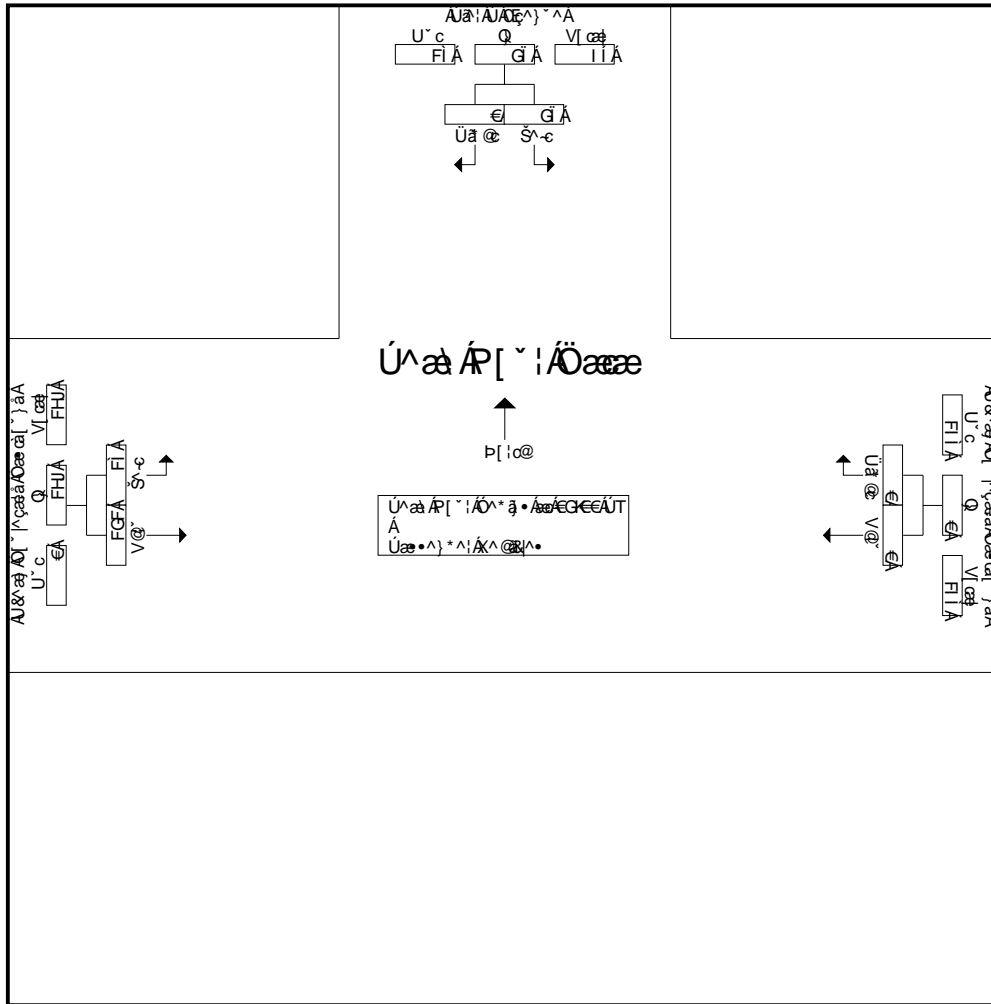

Úãã ÁP[~]!Öãããã•Áãã[! EGEEÁUT Á EGKÍ ÁUT ÁÚãã ÁÁ-Á
 Úãã ÁP[~]!Á[!ÖãããQÁ]!|ããÖÁ^*ã•ÁãK

	EGEEÁUT			EGEEÁUT			EGEEÁUT		
ÉÉÁ ã•É	í	€	í	€	€	€	6	G	H
ÉFÍ Á ã•É	F	€	F	€	€	€	í	HF	36
ÉHEÁ ã•É	J	€	J	€	€	€	H	HE	HH
ÉIÁ ã•É	11	€	11	€	€	€	I	32	H
VI cããK[]{ ^	G	€	G	€	€	€	FI	FGF	FHU
Á ÁQ EV[cã	FEE	€	Á	€	€	€	FGG	ííE	Á
ÚPØ	E FI	E€€	E FI	E€€	E€€	E€€	Eí€	Eíí	Eíí

Ö[] • ÁV[] ä á ÁQ&É
 UUÁÖ[] cÁFI I
 Ö[] : } äÖÖÁG I I
 QI FDG i È G I

Öä Á -Á[] * Á^ ä@
 ÞEYÁUá:ÁUÁÖ[] ^ ^
 ÖEY ÁU&á ÁÖ[] ^cááÁÖä cá[] á
 Y ^ ä@:ÁU[] } }

Öä Á ä ^ KÖÖÓUW ÖÖÓT Ö
 Uä ÁÖ[] á ^ KÉÉÉÉÉÉF
 ÜcááÁÖä KÁHÉÉÉFG
 Uä ^ Á[] KÁ

Ö[] • ÁU[] á cáÁÖ[] ä cáÁV[] & •

ÜcááÁV[] ^	Uä:ÁUÁÖ[] ^ ^ U[] ^ c@ [] ^ á			U&á ÁÖ[] ^cááÁÖä cá[] á Y ^ • cá[] ^ á			U&á ÁÖ[] ^cááÁÖä cá[] á Öä cá[] ^ á			Q cÁV[] c@
	Š^c	Üä @	Ö[] ÉV[] c@	V@~	Üä @	Ö[] ÉV[] c@	Š^c	V@~	Ö[] ÉV[] c@	
€K€ÁÜT	H	€	H	€	€	€	H	FI	FI	GE
€KÍ ÁÜT	FI	€	FI	€	€	€	F	G	G	I I
€K€ÁÜT	í	€	í	€	€	€	I	IF	I I	I F
€KÍ ÁÜT	í	€	í	€	€	€	í	HG	H	I I
V[] c@	H	€	H	€	€	€	FI	FFI	FG	FI H
€K€ÁÜT	í	€	í	€	€	€	í	G	HH	I €
€KÍ ÁÜT	FG	€	FG	€	€	€	G	G	GJ	I F
€K€ÁÜT	F€	€	F€	€	€	€	H	H	H	I I
€KÍ ÁÜT	FJ	€	FJ	€	€	€	F	HF	HG	I F
V[] c@	I I	€	I I	€	€	€	FG	FFJ	FHF	FI J
Ö[] á ÁV[] c@	í H	€	í H	€	€	€	G	GH	G J	H G
Ö[] : & @ Á	F€€	€	Á	€	€	Á	F€	J€	Á	Á
V[] c@ Á	G ÈH	€	G ÈH	€	€	€	í È	í í È	í í È	

ÜcááÁV[] ^	Uä:ÁUÁÖ[] ^ ^ U[] ^ c@ [] ^ á			U&á ÁÖ[] ^cááÁÖä cá[] á Y ^ • cá[] ^ á			U&á ÁÖ[] ^cááÁÖä cá[] á Öä cá[] ^ á			Q cÁV[] c@
	Š^c	Üä @	Ö[] ÉV[] c@	V@~	Üä @	Ö[] ÉV[] c@	Š^c	V@~	Ö[] ÉV[] c@	
Üä ÁV[] : ÁÖ[] á ÁV[] { €K€ÁÜT Á €KÍ ÁÜT ÁUá ÁV[] Á										
Üä ÁV[] : ÁV[] cá ÁÖ[] • ^ & @ } ÁUá • Á€K€ÁÜT										
€K€ÁÜT	í	€	í	€	€	€	6	G	HH	I €
€KÍ ÁÜT	FG	€	FG	€	€	€	G	G	GJ	I F
€K€ÁÜT	F€	€	F€	€	€	€	H	34	37	I I
€KÍ ÁÜT	19	€	19	€	€	€	F	HF	HG	51
V[] c@ ÁV[] ^	I I	€	I I	€	€	€	FG	FFJ	FHF	FI J
Á ÁÖ[] ÉV[] c@	F€€	€	Á	€	€	Á	J€G	J€È	Á	Á
UPØ	È HG	€€€	È HG	€€€	€€€	€€€	È €€	È í í	È í í	È í í

Ó[~},oÁM|ã,ããQ&É
UUÁQ)cAFfii
Ó[![]}ãÖÖÁG di
QlFDG i È d i

Óã Á -S[]}*Á^ã@
PBUÁJã:ÁU/CE^)*^
OEY KÁU&ã ÁQ[]^çããÁÖæ cã[~]ã
Y^ã@:KÁ)}^

Qã Áã^ KÖÓÓUW ÖÓÓT Ö
Uã ÁQ[]ã^ KEEEEEEF
UããÖÖæ KãEFDEFG
Uã^Á[] KãG

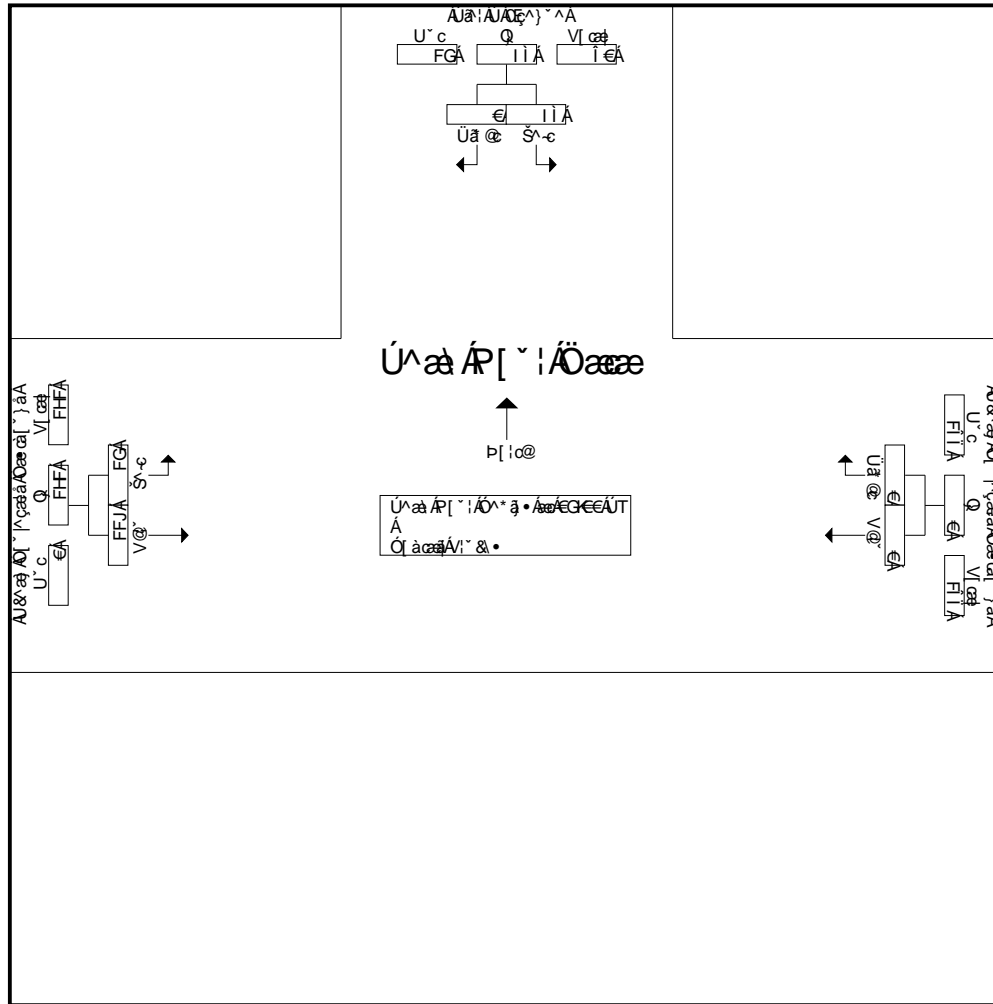

Úãá ÁR[~]!ÖÖãã *ãã ÁQ[] EGEEÁUT Á EGKI ÁUT ÁÁUãã ÁÁ -Á
Úãá ÁR[~]!Á!ÖÖæ cã[~]![]ããÖÖãã *ãã ÁãK

	EGEEÁUT			EGEEÁUT			EGEEÁUT		
ÉÉÁ ã•É	í	€	í	€	€	€	6	G:	HH
ÉFí Á ã•É	FG	€	FG	€	€	€	G	G:	GJ
ÉHÉ Á ã•É	F€	€	F€	€	€	€	H	34	37
Éí Á ã•É	19	€	19	€	€	€	F	HF	HG
Vl cãK[]^	ii	€	ii	€	€	€	FG	FFJ	FHF
Á Á[]EV[]cã	F€€	€	Á	€	€	Á	JEG	J€€	Á
ÚPØ	È HG	È€€	È HG	È€€	È€€	È€€	È €€	È í í	È í í

Ö[~], ◦ ÁM |ã ã á ÁQ&É
 UUÁÖ[cÁFI I
 Ö[] :ã ÆÖÖÁG I I
 QI FDG i È G I

Öã Á -Á[] * Á^ã@
 ÞÐUÁUã: ÁUÁÖ[] ^ ^
 ÖEY KÁU&ã ÁÖ[] ^ çããáÁÖã cá[] á
 Y ^ã@: KÁU } }

Öã Áã ^ KÖÓÓUW ÖÓÓT Ö
 Uã ÁÖ[] á^ KÉÉÉÉÉÉÉF
 UããÖãã KÁBDEFG
 Uã ^ Á[] KÁ

Ö[] ~ ÁUã çã ÆÖÖã ÁU } Á/ ~ & •

UããÁã ^	Uã: ÁUÁÖ[] ^ ^ U[~ c@] ~ á			U&ã ÁÖ[] ^ çããáÁÖã cá[] á Y ^ • cá[] á			U&ã ÁÖ[] ^ çããáÁÖã cá[] á Öã cá[] á			Q cÁV[çã]
	Š^c	Üã @	Ö[] ÈV[çã]	V@~	Üã @	Ö[] ÈV[çã]	Š^c	V@~	Ö[] ÈV[çã]	
€K€ÁÜT	€	€	€	€	€	€	F	F	G	G
€KÍ ÁÜT	F	€	F	€	€	€	H	G	I	I
€K€ÁÜT	F	€	F	€	€	€	F	G	H	I
€KÍ ÁÜT	F	€	F	€	€	€	H	I	FE	FF
V[çã]	H	€	H	€	€	€	I	FG	GE	GH
€K€ÁÜT	€	€	€	€	€	€	H	FF	FI	FI
€KÍ ÁÜT	H	€	H	€	€	€	F	I	I	I
€K€ÁÜT	F	€	F	€	€	€	F	I	J	FE
€KÍ ÁÜT	G	€	G	€	€	€	F	I	I	J
V[çã]	I	€	I	€	€	€	I	GJ	H	IF
Ö[] á ÁV[çã]	J	€	J	€	€	€	FI	IF	II	II
Ö[] : & @ Á	FE€	€	Á	€	€	Á	GÍ È	I I È	Á	Á
V[çã] Á	FI È	€	FI È	€	€	€	GFÈ	I I È	I I È	

UããÁã ^	Uã: ÁUÁÖ[] ^ ^ U[~ c@] ~ á			U&ã ÁÖ[] ^ çããáÁÖã cá[] á Y ^ • cá[] á			U&ã ÁÖ[] ^ çããáÁÖã cá[] á Öã cá[] á			Q cÁV[çã]
	Š^c	Üã @	Ö[] ÈV[çã]	V@~	Üã @	Ö[] ÈV[çã]	Š^c	V@~	Ö[] ÈV[çã]	
Uãã ÁV[] : Ö[] á ÁV[] { €K€ÁÜT Á €KÍ ÁÜT Á Uãã ÁV[] - Á										
Uãã ÁV[] : ÁV[] cá ÁQ[] • ^ & @ } Á^ã • Áã €K€ÁÜT										
€K€ÁÜT	€	€	€	€	€	€	3	11	14	14
€KÍ ÁÜT	3	€	3	€	€	€	F	I	I	I
€K€ÁÜT	F	€	F	€	€	€	F	I	J	FE
€KÍ ÁÜT	G	€	G	€	€	€	F	I	I	J
V[çã] ÁV[] { ^	I	€	I	€	€	€	I	GJ	H	IF
Á Ö[] ÈV[çã]	FE€	€	Á	€	€	Á	FI È	I GÈ	Á	Á
UPØ	È €€	È €€	È €€	È €€	È €€	È €€	È €€	È I J	È G	È HG

Ö [] , o Á M | a a a Q & E
 U U A O | c A F F I I
 Ö [] [] a a Ö O A U G I I
 Q I F D G I E G I

Ö a Á - A [] * A ^ a a @
 P B U I A U a : A U / C E ^) ^ ^
 O E Y K A U & a a A O [] ^ c a a A O a e a [] a
 Y ^ a a @ : I K A U } } }

Q a A a a ^ K S O O U W O O O T Ö
 U a A O [] a ^ K E E E E E E E F
 U a a o A a a K A B D E F G
 U a e ^ A p K G

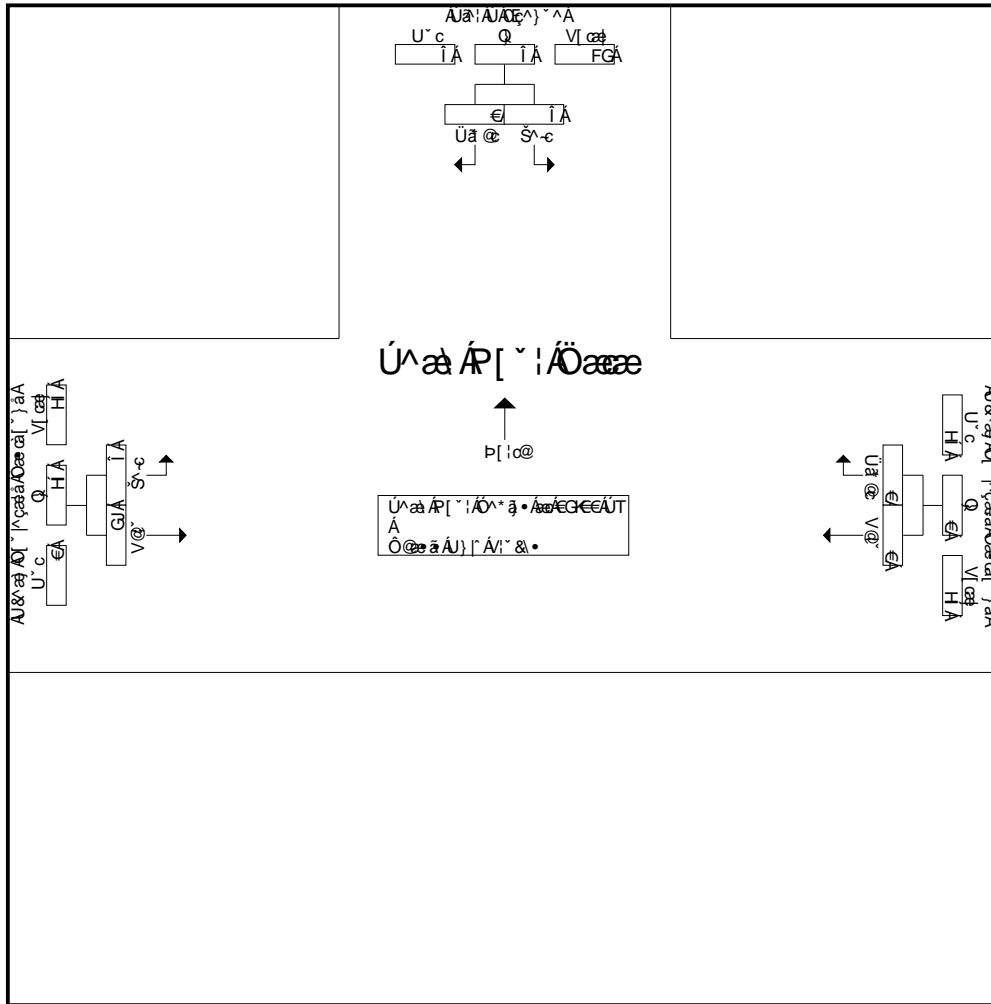

Ú a a Á P [] ^ I Ö a a e a A O [] { A E G E E A U T A F A E G K I A U T A E U a a A F A - A
 Ú a a Á P [] ^ I A : A O a a O I I [] a a @ A ^ a a A a K

	E G E E A U T			E G E E A U T			E G E E A U T			
É E Á a • É	€	€	€	€	€	€	€	3	11	14
É F I Á a • É	3	€	3	€	€	€	€	F		í
É H E Á a • É	F	€	F	€	€	€	€	F		J
É I Á a • É	G	€	G	€	€	€	€	F		í
V I c a a K [] { ^	í	€	í	€	€	€	€	í	GJ	H
Á A O H [] E V [] c a a	F € €	€	Á	€	€	€	Á	F I E	í G E	Á
Ú P Ø	E € €	E € €	E € €	E € €	E € €	E € €	E € €	E € €	E € €	E € €

Ö[] • ÁV[] ä á ÁQ&E
 UUÁÖ[] cÁFI
 Ö[] : } äÖÖÁGII
 QI FDG i È G I

Öä Á -Á[] * Á^ ä@
 ÞEJKA:Á/Ö^ ^
 ÖY KA&á Á[] ^çääÁÖä cá[] á
 Y ^ ä@:KA[] }

Öä Á ä ^ KÖÖÓUW ÖÖÓT Ö
 Üä ÁÖ[] á^ KEEEEEEF
 ÜääÖä KÁBDEFG
 Üä ^ Á[] KÁ

Ö[] • ÁV[] ä á ÁQ&E

ÜääÁ/á ^	Üä:Á/Ö^ ^ Ü[] cÁ[] á			U&á ÁÖ[] ^çääÁÖä cá[] á Y ^ • cá[] á			U&á ÁÖ[] ^çääÁÖä cá[] á Öä cá[] á			Q cÁ[] cæ
	Š^c	Üä @	Ö[] ÈV[] cæ	V@~	Üä @	Ö[] ÈV[] cæ	Š^c	V@~	Ö[] ÈV[] cæ	
€K€ÁÜT	€	€	€	€	€	€	€	FJ	FJ	FJ
€KÍ ÁÜT	I	€	I	€	€	€	F	FF	FG	FÍ
€K€ÁÜT	í	€	í	€	€	€	F	GF	GG	G
€KÍ ÁÜT	í	€	í	€	€	€	G	HÍ	HÍ	IG
V[] cæ	FI	€	FI	€	€	€	I	IÍ	J€	F€
€K€ÁÜT	G	€	G	€	€	€	G	HÍ	I€	IG
€KÍ ÁÜT	H	€	H	€	€	€	H	GÍ	H€	HH
€K€ÁÜT	í	€	í	€	€	€	F	HG	HH	HJ
€KÍ ÁÜT	J	€	J	€	€	€	F	GJ	H€	HJ
V[] cæ	ÖE	€	ÖE	€	€	€	í	FG	FHH	FÍH
Ö[] áÁV[] cæ	H	€	H	€	€	€	FF	GFG	GGH	GÍ
Ö[] :&@Á	F€€	€	Á	€	€	Á	I È	JÍ È	Á	Á
V[] cæÁ	FHG	€	FHG	€	€	€	I ÈH	I GÈ	IÍ È	

ÜääÁ/á ^	Üä:Á/Ö^ ^ Ü[] cÁ[] á			U&á ÁÖ[] ^çääÁÖä cá[] á Y ^ • cá[] á			U&á ÁÖ[] ^çääÁÖä cá[] á Öä cá[] á			Q cÁ[] cæ
	Š^c	Üä @	Ö[] ÈV[] cæ	V@~	Üä @	Ö[] ÈV[] cæ	Š^c	V@~	Ö[] ÈV[] cæ	
Üä Á[] : Á[] á Á[] { €K€ÁÜT Á €KÍ ÁÜT ÁÜä ÁÁ -Á										
Üä Á[] : Á[] á Á[] cÁ[] • Á[] } Á^ á • Á€K€ÁÜT										
€K€ÁÜT	G	€	G	€	€	€	G	38	40	42
€KÍ ÁÜT	H	€	H	€	€	€	3	GÍ	H€	HH
€K€ÁÜT	í	€	í	€	€	€	F	HG	HH	HJ
€KÍ ÁÜT	9	€	9	€	€	€	F	GJ	H€	HJ
V[] cæÁ[] ^	ÖE	€	ÖE	€	€	€	í	FG	FHH	FÍH
Á Ö[] ÈV[] cæ	F€€	€	Á	€	€	Á	I ÈH	JÍ È	Á	Á
UPØ	ÈÍÍ	È€€	ÈÍÍ	È€€	È€€	È€€	ÈÍH	ÈGJ	ÈHF	ÈFF

Ö[] • ÁV[] ä á ÁQ&É
 UUÁÖ[] cÁFíí
 Ö[] : : äÖÖÁGíí
 Qí FÖGí ÈGí

Öä Á -Á[] * Á^ ä@
 ÞÖUÁUá: ÁUÖE^ } ^
 ÖEY ÁU&á Ö[] ^çääÁÖä cá[] á
 Y ^ ä@: ÁU } }

Öä Á ä ^ KÖÖÓUWÖÖÓT Ö
 Uä ÁÖ[] á^ KÉÉÉÉÉÉF
 ÜääÖÖä KÁBDEFG
 Uä ^ Á[] KÁ

Ö[] • ÁUá c á ÄUö@Á/í • & •

ÜääÖÁ/á ^	Uä: ÁUÖE^ } ^ U[] c@ [] á			U&á Ö[] ^çääÁÖä cá[] á Y ^ • cá[] á			U&á Ö[] ^çääÁÖä cá[] á Öä cá[] á			Q cÁV[] cæ
	Š^c	Üä @	Ö[] ÈV[] cæ	V@~	Üä @	Ö[] ÈV[] cæ	Š^c	V@~	Ö[] ÈV[] cæ	
€K€ÁÜT	F€	€	F€	€	€	€	F	F	G	FG
€Kí ÁÜT	ì	€	ì	€	€	€	G	F	H	FF
€K€ÁÜT	ì	€	ì	€	€	€	F	ì	ì	Fí
€Kí ÁÜT	H	€	H	€	€	€	F	€	F	I
V[] cæ	GJ	€	GJ	€	€	€	í	í	FH	IG
€K€ÁÜT	H	€	H	€	€	€	G	G	I	ì
€Kí ÁÜT	H	€	H	€	€	€	F	G	H	ì
€K€ÁÜT	ì	€	ì	€	€	€	F	H	I	F€
€Kí ÁÜT	ì	€	ì	€	€	€	€	€	€	ì
V[] cæ	Fí	€	Fí	€	€	€	I	ì	FF	GJ
Ö[] ä ÁV[] cæ	Ií	€	Ií	€	€	€	J	Fí	G	ì F
Ö[] : & @ Á	F€€	€	Á	€	€	Á	Hí È	ì GÈ	Á	Á
V[] cæ Á	ì í ÈG	€	ì í ÈG	€	€	€	F GÈ	G FÈ	H È	

ÜääÖÁ/á ^	Uä: ÁUÖE^ } ^ U[] c@ [] á			U&á Ö[] ^çääÁÖä cá[] á Y ^ • cá[] á			U&á Ö[] ^çääÁÖä cá[] á Öä cá[] á			Q cÁV[] cæ
	Š^c	Üä @	Ö[] ÈV[] cæ	V@~	Üä @	Ö[] ÈV[] cæ	Š^c	V@~	Ö[] ÈV[] cæ	
Uä ÁV[] : Ö[] ä ÁV[] { €K€ÁÜT Á €Kí ÁÜT ÁUä ÁV[] Á										
Uä ÁV[] : ÁV[] cá ÁQ: ^ & @ } Á^ á • Á€K€ÁÜT										
€K€ÁÜT	H	€	H	€	€	€	2	G	4	ì
€Kí ÁÜT	H	€	H	€	€	€	F	G	H	ì
€K€ÁÜT	6	€	6	€	€	€	F	3	I	10
€Kí ÁÜT	ì	€	ì	€	€	€	€	€	€	ì
V[] cæ ÁV[] { ^	Fí	€	Fí	€	€	€	I	ì	FF	GJ
Á Ö[] ÈV[] cæ	F€€	€	Á	€	€	Á	Hí È	ì HÈ	Á	Á
UPØ	È í €	È €€	È í €	È €€	È €€	È €€	È €€	È í H	È í í	È G

Ó[~}·ÁM|ã.ãáQ&É
 UUÁQ|cÁFIÍ
 Ó[!|]ãÖÖÁGÍÍ
 QÍFÁGÍÉGÍ

Óã Á -Á[]*Á^ã@
 PDUÁJá:AU/CE^)^
 OEY KÁJ&ã ÁO[^ÇãáÁÖã cá[~] á
 Y^ã@:KÁ"}}

Qã Áã ^ KÖÓÓUΩÓÓÓ Ö
 Úã ÁO[á^ KEEEEEEF
 ÚããÖÖã KÁBDEFG
 Úã^ÁP[KÁG

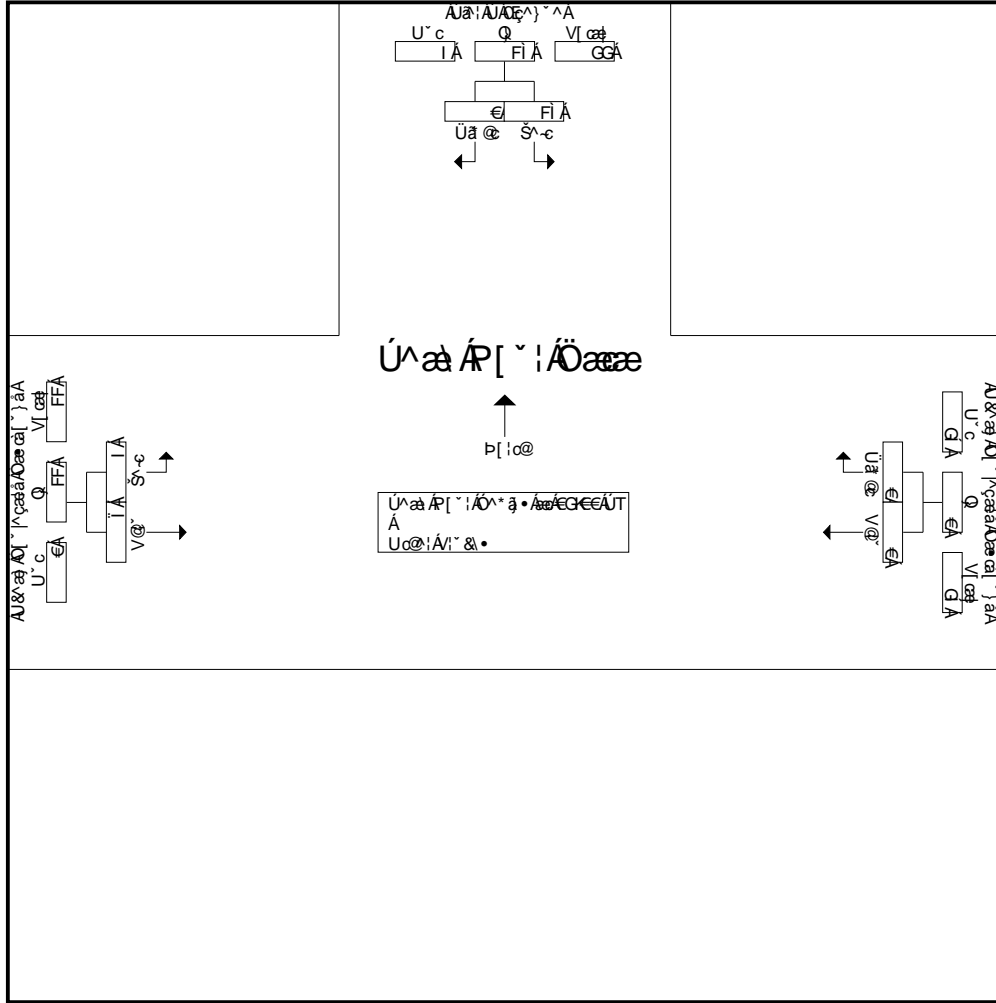

Ú^ã ÁP[~|ÁÖãæ·ÁÁO[| ÁEGEEÁUT ÁEGKÍ ÁUT ÁÚ^ã ÁÁ-Á
 Ú^ã ÁP[~|ÁÖãæO[!|]ã@Á^ã·ÁãK

	EGEEÁUT			EGEEÁUT			EGEEÁUT		
ÉÉÁ ã·É	H	€	H	€	€	€	2	G	4
ÉFÍ Á ã·É	H	€	H	€	€	€	F	G	H
ÉHEÁ ã·É	6	€	6	€	€	€	F	3	I
ÉÍ Á ã·É	í	€	í	€	€	€	€	€	€
V I çãK]{ ^	FÍ	€	FÍ	€	€	€	I	Í	FF
Á ÁCH EV çã	FEE	€	Á	€	€	€	H Í	í H	Á
ÚPØ	É Í €	ÉÉ€	É Í €	ÉÉ€	ÉÉ€	ÉÉ€	É É €	É Í H	É Í I

Ó[~]•ÁV|ããáÁ&É
 UUÁÓçÁFÍÍ
 Ó[~]•áÁÓçÁGÍÍ
 QÍFÍGÍÉÍ

Óã Á-Á[~]•Á^ã@
 ÞHÍÁÚã:Á/Ö^~^
 ÖY ÁÚ&ã ÁÓ[~]çããÁÖã cá[~]ã
 Y^ã@:ÁÚ[~]}}

ÖÁ Áã ^ KÖÓÓÚWÖÓÓÚT
 Úã ÁÓ[~]ã KÉÉÉÉÉÉÉÉÉÉ
 Úã Öã KÁÞÐÉFG
 Úã ÁÁ[~] KÁ

Ó[~]•ÁV|ããáÁÖã•^~^Á^Öã•ÁÖ|ããÁV|•&•ÁÖÖããÁÚ|~^ÁV|•&•ÁÖ|ããÁV|•&•ÁÚÖã:ÁV|•&•

ÚããÁ/ã ^	Úã:ÁÚÖ^~^ Ú[~]Öã[~]ã			U&ã ÁÓ[~]çããÁÖã cá[~]ã Y^•cá[~]ã			U&ã ÁÓ[~]çããÁÖã cá[~]ã Öã cá[~]ã			QÖÁV[~]ã
	Š^c	Üã @	Ö[~]ÉV[~]ã	V@~	Üã @	Ö[~]ÉV[~]ã	Š^c	V@~	Ö[~]ÉV[~]ã	
É KÉÁÚT	FÍ	€	FÍ	€	€	€	F€	FÍ	FÍ	FÍ H
É KÍ ÁÚT	FÍ	€	FÍ	€	€	€	F€	FÍ€	FÍ€	FÍ
É KÉÁÚT	G	€	G	€	€	€	FÍ	F€F	FFÍ	FÍ€
É KÍ ÁÚT	G	€	G	€	€	€	G€	JG	FFG	FHJ
V[~]ã	ÍÍ	€	ÍÍ	€	€	€	ÍÍ	ÍÍ€	ÍH	ÍG€
É KÉÁÚT	FJ	€	FJ	€	€	€	G€	ÍG	JG	FFF
É KÍ ÁÚT	FH	€	FH	€	€	€	GG	ÍÍ	ÍÍ	F€F
É KÉÁÚT	Í	€	Í	€	€	€	G	ÍÍ	ÍÍ	ÍG
É KÍ ÁÚT	€	€	€	€	€	€	Í	ÍÍ	ÍF	ÍF
V[~]ã	H	€	H	€	€	€	ÍÍ	G€	H€	HÍ
Ó[~]ãÁV[~]ã	FGH	€	FGH	€	€	€	FHG	ÍF€	ÍÍG	JÍÍ
Ö[~]:&ÖÁ	F€€	€	Á	€	€	Á	FÍÉ	ÍÍÉH	Á	Á
V[~]ãÁ	F€É	€	F€É	€	€	€	F€É	ÍHÉ	ÍÍÉH	
Úã•^~^Á^Öã•	ÍÍ	€	ÍÍ	€	€	€	F€	HÍH	ÍÍF	ÍÍÍ
Á Úã•^~^Á^Öã•	ÍJÉ	€	ÍJÉ	€	€	€	ÍF€	ÍG€	ÍÍÉ	ÍÍÉ
Ó[~]ãÁV •&•	FÍ	€	FÍ	€	€	€	FH	FHÍ	FÍJ	FÍ
Á ÁÓ[~]ãÁV •&•	F€G	€	F€G	€	€	€	JÉ	FJ€G	FÍÉ	FÍ
ÖããÁÚ ~^ÁV •&•	F	€	F	€	€	€	G	G	GH	G
Á ÁÖããÁÚ ~^ÁV •&•	€É	€	€É	€	€	€	F€	H	G€	G€
Ó[~]ãÁV •&•	FH	€	FH	€	€	€	H	FÍ	FÍ€	FÍH
Á ÁÓ[~]ãÁV •&•	F€É	€	F€É	€	€	€	G€H	G€É	G€G	FJ
Uö:ÁV •&•	J	€	J	€	€	€	Í	FH	FJ	G
Á ÁÚö:ÁV •&•	ÍÉH	€	ÍÉH	€	€	€	ÍÉ	F€	G€H	G€

ÚããÁ/ã ^	Úã:ÁÚÖ^~^ Ú[~]Öã[~]ã			U&ã ÁÓ[~]çããÁÖã cá[~]ã Y^•cá[~]ã			U&ã ÁÓ[~]çããÁÖã cá[~]ã Öã cá[~]ã			QÖÁV[~]ã	
	Š^c	Üã @	Ö[~]ÉV[~]ã	V@~	Üã @	Ö[~]ÉV[~]ã	Š^c	V@~	Ö[~]ÉV[~]ã		
U^ã ÁP[~]!ÁÖ[~]ã•áÁÖ[~]ã	É KÉÁÚT	FÍ	€	FÍ	€	€	€	F€	147	157	173
U^ã ÁP[~]!Á:ÁÖ[~]ã•^ã&ç[~]ã	É KÍ ÁÚT	FÍ	€	FÍ	€	€	€	F€	FÍ€	FÍ€	FÍ
U^ã ÁP[~]!Á:ÁÖ[~]ã•^ã&ç[~]ã	É KÉÁÚT	G	€	G	€	€	€	FÍ	F€F	FFÍ	FÍ€
U^ã ÁP[~]!Á:ÁÖ[~]ã•^ã&ç[~]ã	É KÍ ÁÚT	27	€	27	€	€	€	20	JG	FFG	FHJ
V[~]ãÁV[~]ã	ÍÍ	€	ÍÍ	€	€	€	ÍÍ	ÍÍ€	ÍH	ÍG€	
Á ÁÖ[~]ãÁV[~]ã	F€€	€	Á	€	€	Á	F€H	ÍJÉ	Á	Á	
UPØ	ÉÍÍ	€€€	ÉÍÍ	€€€	€€€	€€€	ÉÍÍ	ÉFÍ	ÉÍG	ÉJÍ	

Ó[~}•ÁM|ã.ããÁQ&É
 UUÁQ|cÁFíí
 Ó[!|}ãÖÖÁV Gíí
 Qí FÁ Gí È Gí

Óã Á -Á[] * Á^ã@
 ÞÉUÁUã:ÁUÁE^} ^
 ÖEY ÁU&ã ÁQ[] ^çããÁÖãã à[] á
 Y ^ã@:KÁU"} }

Qã Áãã ^ KÖÖÓUWÖÖÓÚT
 Úã ÁQ[] á^ KÉÉÉÉÉÉÉF
 ÚããÖÖãã KÁHÞEFG
 Úã ^Á[] KÁG

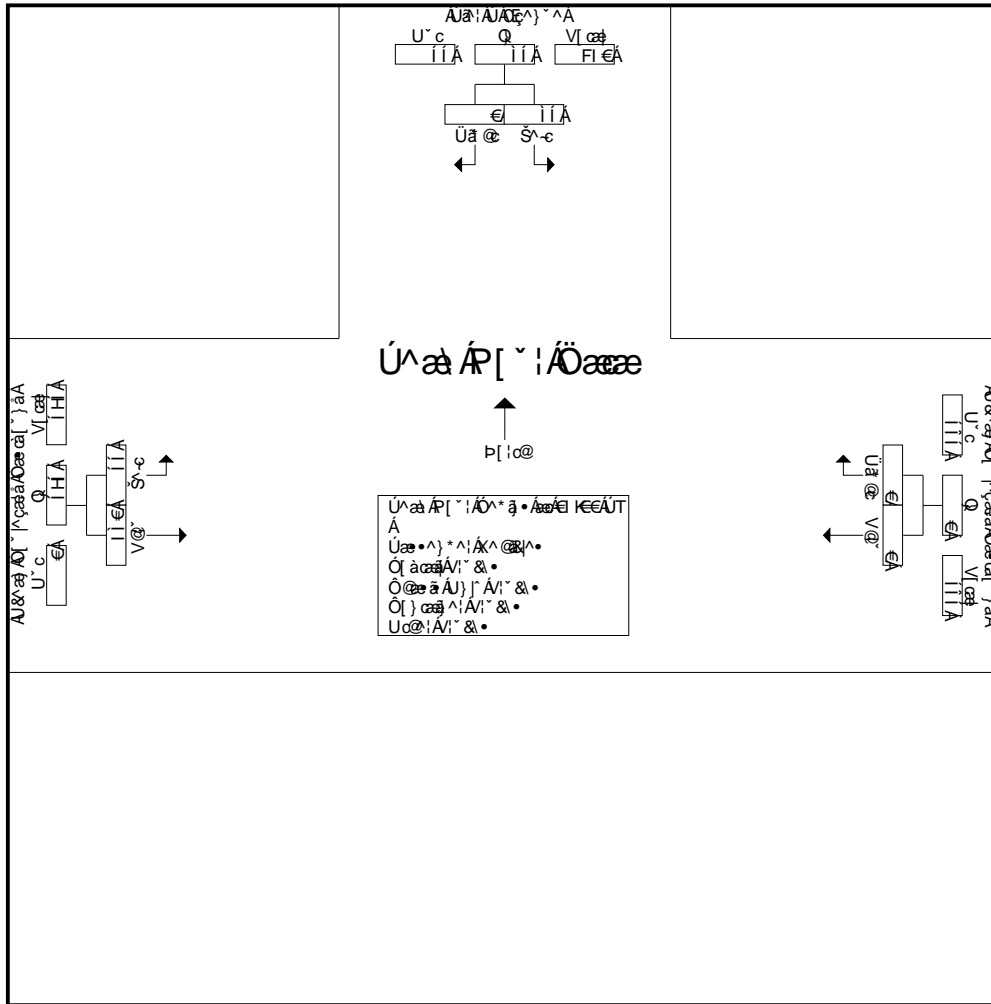

Ú^ã ÁR[] ^ ! ÁÖãææ
 Ú^ã ÁR[] ^ ! ÁÖãææ

	€í KEEÁÚT			€í KEEÁÚT			€í KEEÁÚT		
ÉÉÁ á•É	Fí	€	Fí	€	€	€	F€	147	157
ÉFí Á á•É	Fí	€	Fí	€	€	€	F€	Fí€	Fí€
ÉHÁ á•É	G	€	G	€	€	€	Fí	F€F	FFí
Éí Á á•É	27	€	27	€	€	€	20	JG	FFG
VíçãK[] { ^	íí	€	íí	€	€	€	íí	íí€	íí
Á ÁH] ÉV] çã	F€€	€	Á	€	€	€	F€H	í J€	Á
ÚPØ	Èíí	È€€	Èíí	È€€	È€€	È€€	Èíí	ÈFí	ÈíG

Ó[~]·ÁM|ã à^ÁQ&É
 UUÁÓ cÁFíí
 Ó[í]·ãÁÓáGíí
 Qí FdG í È G í

Óã Á -Á[]*Á^ã@
 ÞEYKÁU&áÁ[~]·^
 ÓEY KÁU&áÁ[~]·^çãáÁÓã cá[~] á
 Y^ã@:KÁU}}^

Óã Áã ^ KÁÓÓÚWÓÓÓÚT
 Úã ÁÓ[á^ KÁEÉÉÉÉÉF
 Úã ÓÁã KÁEÉÉÉÉFG
 Úã ÁÁ[KÁF

Ó[í]·ÁM|ã à^ÁQ&É*Á^ÁQ&É

Úã ÓÁã ^	Úã ÁÁÓÁ[~]·^ Ú[~]·çã[~] á			U&á ÁÓ[~]·^çãáÁÓã cá[~] á Y^·çã[~] á			U&á ÁÓ[~]·^çãáÁÓã cá[~] á Óã cá[~] á			Q çÁV[çã]
	Š^·c	Üã @	ÖH] ÈV[çã]	V@~	Üã @	ÖH] ÈV[çã]	Š^·c	V@~	ÖH] ÈV[çã]	
É KÉÁÚT	í	€	í	€	€	€	G	íí	íí	íG
É KÍ ÁÚT	J	€	J	€	€	€	í	íF	íí	íí
É KÉÁÚT	FI	€	FI	€	€	€	FH	í€	íH	íí
É KÍ ÁÚT	G	€	G	€	€	€	FJ	íí	íí	FF€
V[çã]	íG	€	íG	€	€	€	í€	GGH	G H	HFI
É KÉÁÚT	Fí	€	Fí	€	€	€	Fí	íJ	íí	JG
É KÍ ÁÚT	FF	€	FF	€	€	€	G€	íF	íF	íG
É KÉÁÚT	í	€	í	€	€	€	G	G	í€	íí
É KÍ ÁÚT	€	€	€	€	€	€	í	G	HG	HG
V[çã]	HH	€	HH	€	€	€	íí	Fí€	Gí	G F
Ó[á] áÁV[çã]	íí	€	íí	€	€	€	Féí	HíH	ííF	ííí
ÖH] :&@Á	F€€	€	Á	€	€	€	G€É	ííÈ	Á	Á
V[çãÁ	Fí	€	Fí	€	€	€	FJÈ	ííÈ	íí	

Úã ÓÁã ^	Úã ÁÁÓÁ[~]·^ Ú[~]·çã[~] á			U&á ÁÓ[~]·^çãáÁÓã cá[~] á Y^·çã[~] á			U&á ÁÓ[~]·^çãáÁÓã cá[~] á Óã cá[~] á			Q çÁV[çã]
	Š^·c	Üã @	ÖH] ÈV[çã]	V@~	Üã @	ÖH] ÈV[çã]	Š^·c	V@~	ÖH] ÈV[çã]	
Úã ÁÁ[~]·^çãáÁÓã cá[~] á										
Úã ÁÁ[~]·^çãáÁÓã cá[~] á										
É KÉÁÚT	í	€	í	€	€	€	G	íí	íí	íG
É KÍ ÁÚT	J	€	J	€	€	€	í	íF	íí	íí
É KÉÁÚT	FI	€	FI	€	€	€	FH	í€	íH	íí
É KÍ ÁÚT	24	€	24	€	€	€	19	67	86	110
V[çãÁ[~]·^	íG	€	íG	€	€	€	í€	GGH	G H	HFI
Á ÁÖH] ÈV[çã]	F€€	€	Á	€	€	€	FíÈ	ííÈ	Á	Á
UPØ	È íG	È€€	È íG	È€€	È€€	È€€	È G	È HG	È íí	È Fí

Ó[~}oÁM|ãããQ&É
 UUÁO|cÁFíí
 Ó[!|}ãÖÖÁGíí
 QíFíGíÉí

Óã Á-Á[~}^Á^ã@
 ÞÐJKAJã:AU/CE^}^
 ÖEY KA&ã AJ[~}^çããÁÖãã[~}ã
 Y^ãã@:KAU}~}

Qã Áãã ^ KÖÖÓÚWÖÖÓÚT
 Úã ÁÖ[ã^ KÉÉÉÉÉÉÉÉF
 ÚããÖÖãã KÁHÞDÉFG
 Úãã^Áã KÁG

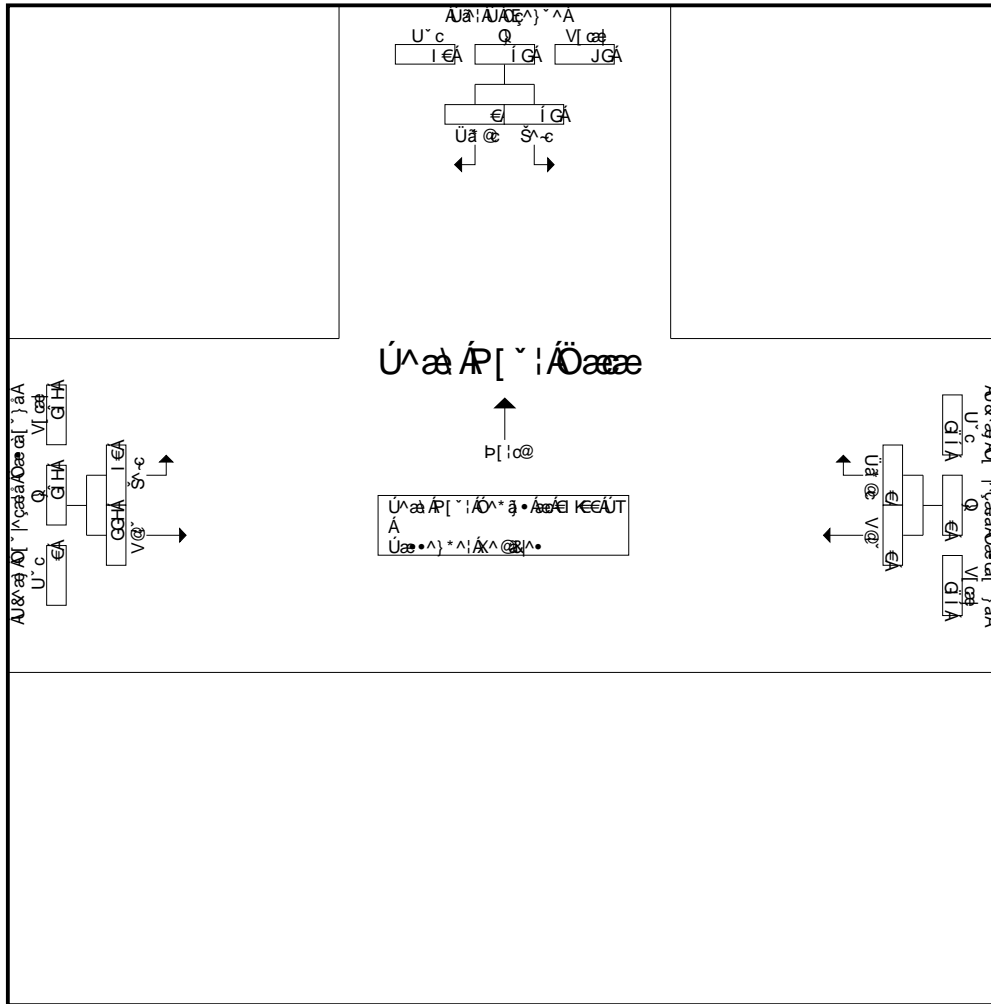

Úãã ÁP[~}!ÖÖãæã ÁP[~}!ÖÖãæ ÁP[~}!ÖÖãæ ÁP[~}!ÖÖãæ ÁP[~}!ÖÖãæ
 Úãã ÁP[~}!ÖÖãæ ÁP[~}!ÖÖãæ ÁP[~}!ÖÖãæ ÁP[~}!ÖÖãæ ÁP[~}!ÖÖãæ

	éí kEEÁÚT			éí kEEÁÚT			éí kEEÁÚT		
ÉÉÁ á•É	í	€	í	€	€	€	G	íí	íí
ÉFí Á á•É	J	€	J	€	€	€	í	íF	íí
ÉHEÁ á•É	FI	€	FI	€	€	€	FH	í€	íH
Éí Á á•É	24	€	24	€	€	€	19	67	86
VI çãKI]~}^	íG	€	íG	€	€	€	I€	GCH	GíH
Á ÁH]ÉV] çã	F€€	€	Á	€	€	Á	FíÉ	ííÉ	Á
UPØ	ÉíG	ÉÉ€€	ÉíG	ÉÉ€€	ÉÉ€€	ÉÉ€€	ÉíG	ÉíHG	Éíí

Ó[~]·ÁV[á]·á·ÁQ&É
 UUÁ[á]·ÁFÍ
 Ó[~]·á·ÁQ&É
 Q[~]·ÁQ&É

Ó[~]·ÁV[á]·á·ÁQ&É
 UUÁ[á]·ÁFÍ
 Ó[~]·á·ÁQ&É
 Q[~]·ÁQ&É

Ó[~]·ÁV[á]·á·ÁQ&É
 UUÁ[á]·ÁFÍ
 Ó[~]·á·ÁQ&É
 Q[~]·ÁQ&É

Ó[~]·ÁV[á]·á·ÁQ&É

Úcá[~]·ÁV[á]·á·ÁQ&É	Ú[~]·ÁV[á]·á·ÁQ&É			U&Á[~]·ÁV[á]·á·ÁQ&É			U&Á[~]·ÁV[á]·á·ÁQ&É			Q[~]·ÁV[á]·á·ÁQ&É
	Š~c	Üä@	Q[~]·ÁV[á]·á·ÁQ&É	V@~	Üä@	Q[~]·ÁV[á]·á·ÁQ&É	Š~c	V@~	Q[~]·ÁV[á]·á·ÁQ&É	
€ K€ÁÚT	í	€	í	€	€	€	í	IG	íí	íG
€ Kí ÁÚT	í	€	í	€	€	€	H	Hí	íF	íí
€ K€ÁÚT	H	€	H	€	€	€	G	Fí	Fí	Q€
€ Kí ÁÚT	€	€	€	€	€	€	F	Fí	Fí	Fí
V[~]·ÁV[á]·á·ÁQ&É	FI	€	FI	€	€	€	FF	FFG	FGH	FHí
€ K€ÁÚT	€	€	€	€	€	€	F	G	H	H
€ Kí ÁÚT	€	€	€	€	€	€	€	í	í	í
€ K€ÁÚT	F	€	F	€	€	€	F	FF	FG	FH
€ Kí ÁÚT	€	€	€	€	€	€	€	í	í	í
V[~]·ÁV[á]·á·ÁQ&É	F	€	F	€	€	€	G	G	G	G
Ó[~]·ÁV[á]·á·ÁQ&É	Fí	€	Fí	€	€	€	FH	FHí	FíJ	Fíí
Q[~]·ÁV[á]·á·ÁQ&É	F€€	€	Á	€	€	Á	íÈ	JFÈH	Á	Á
V[~]·ÁV[á]·á·ÁQ&É	JÈF	€	JÈF	€	€	€	íÈ	íGÈ	J€È	

Úcá[~]·ÁV[á]·á·ÁQ&É	Ú[~]·ÁV[á]·á·ÁQ&É			U&Á[~]·ÁV[á]·á·ÁQ&É			U&Á[~]·ÁV[á]·á·ÁQ&É			Q[~]·ÁV[á]·á·ÁQ&É
	Š~c	Üä@	Q[~]·ÁV[á]·á·ÁQ&É	V@~	Üä@	Q[~]·ÁV[á]·á·ÁQ&É	Š~c	V@~	Q[~]·ÁV[á]·á·ÁQ&É	
U&Á[~]·ÁV[á]·á·ÁQ&É	í	€	í	€	€	€	5	42	47	52
€ K€ÁÚT	6	€	6	€	€	€	H	Hí	íF	íí
€ Kí ÁÚT	H	€	H	€	€	€	G	Fí	Fí	Q€
€ K€ÁÚT	€	€	€	€	€	€	F	Fí	Fí	Fí
V[~]·ÁV[á]·á·ÁQ&É	FI	€	FI	€	€	€	FF	FFG	FGH	FHí
Á Q[~]·ÁV[á]·á·ÁQ&É	F€€	€	Á	€	€	Á	íÈ	JFÈF	Á	Á
UPØ	ÈíH	È€€	ÈíH	È€€	È€€	È€€	Èí€	Èíí	Èíí	ÈíJ

Ó[] , o ÁM | a , a a Q & E
 UU A O | c A F F I
 Ó [|] a a O O A G I i
 Q I F D G I E G I

Ó a r Á - A [] * A O a a @
 P B U I A U a : A U A C E ^) ^ ^
 O E Y K A U & a j A O [] ^ c a a A O a e a [] á
 Y ^ a a @ : K A U } } ^

Q a r A p a j ^ K S O O U W O O O U T
 U a r A O [] á ^ K E E E E E E F
 U c a s o O a e K A B D E F G
 U a e ^ A r K G

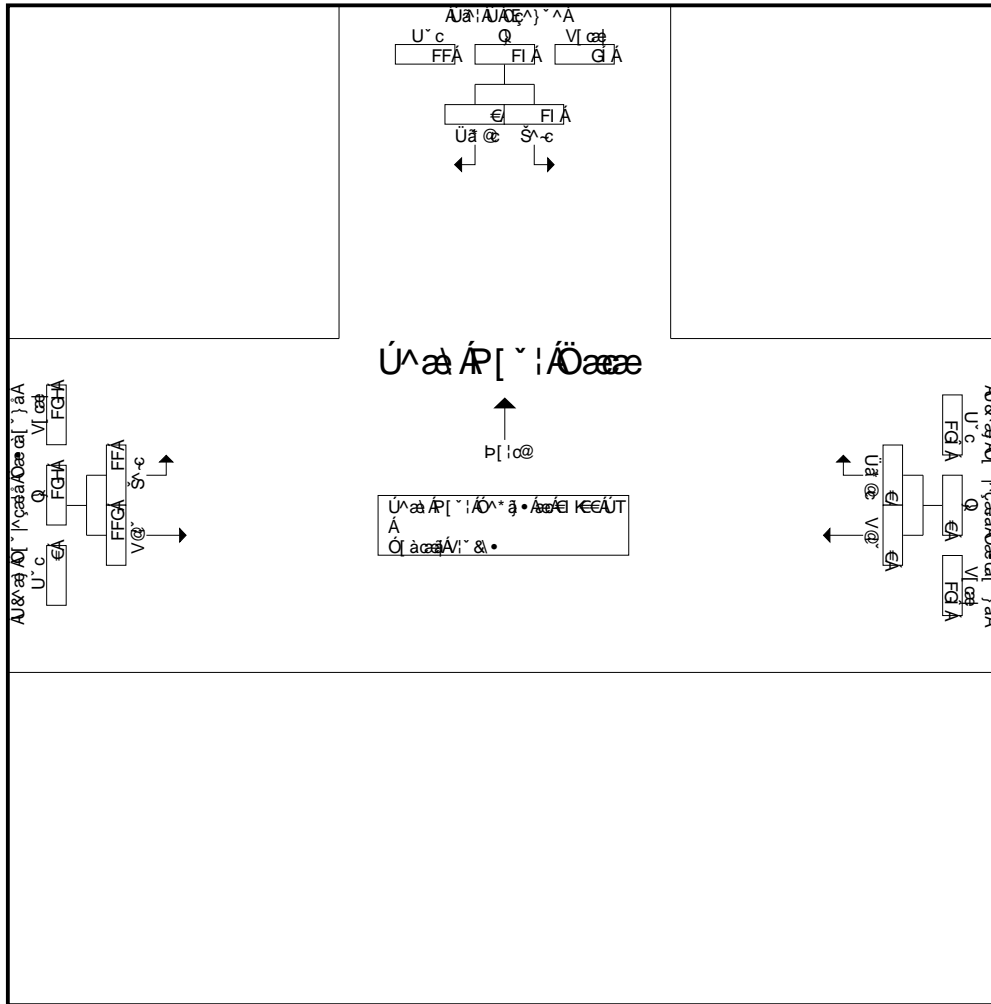

Ú a a Á R [] ^ | Á O a a e a A O [] { A i K E A U T A i A i K I A U T A U a a A A - A
 Ú a a Á R [] ^ | Á O a a e a O [] | | a a O O ^ a . A a K

	€ i K E A U T			€ i K E A U T			€ i K E A U T		
É e Á a . É	í	€	í	€	€	€	5	42	47
É F I Á a . É	6	€	6	€	€	€	H	H	I F
É H A a . É	H	€	H	€	€	€	G	F I	F I
É I Á a . É	€	€	€	€	€	€	F	F I	F i
V i c a j A [] { ^	F I	€	F I	€	€	€	FF	FFG	FGH
Á A C H E V c a j	F € €	€	Á	€	€	€	ì È	J F È	Á
Ú P Ø	È Ì H	È € € €	È Ì H	È € € €	È € € €	È € € €	È Ì €	È Ì Ì	È Ì Ì

Ö[~], ◦ ÁM |ã ã á ÁQ&É
 UUÁÖ[cÁFI I
 Ö[] :ã ÖÖáG I I
 QI FÖG i È G I

Öã Á -Á[] * Á^ã@
 ÞÖUÁUã: ÁUÖE^ ^
 ÖEY KÁU&ã ÁÖ[^ ÇããáÁÖã cá[^] á
 Y ^ã@: KÁU } }

Öã Áã ^ KÖÖÓÚW ÖÖÓÚT
 Uã ÁÖ[á^ KEEEEEEF
 UããÖãã KÁBDEFG
 Uãã^Áã KF

Ö[] : ÁUã çãã ÖÖã ÁU } ÁI^ & ◦

UããÖÁã ^	Uã: ÁUÖE^ ^ ^ U[^ c@ [^] á			U&ã ÁÖ[^ ÇããáÁÖã cá[^] á Y ^ ◦ cá[^] á			U&ã ÁÖ[^ ÇããáÁÖã cá[^] á Öã cá[^] á			Q cÁV[çã
	Š^c	Üã @	Ö[] ÈV[çã	V@~	Üã @	Ö[] ÈV[çã	Š^c	V@~	Ö[] ÈV[çã	
€ KEEÁUT	€	€	€	€	€	€	F	I	I	I
€ KÍ ÁUT	€	€	€	€	€	€	€	í	í	í
€ KKEÁUT	F	€	F	€	€	€	€	í	í	í
€ KÍ ÁUT	€	€	€	€	€	€	€	€	€	€
V[çã	F	€	F	€	€	€	F	FÍ	FÍ	FÍ
€ KEEÁUT	€	€	€	€	€	€	€	F	F	F
€ KÍ ÁUT	€	€	€	€	€	€	€	€	€	€
€ KKEÁUT	€	€	€	€	€	€	€	F	F	F
€ KÍ ÁUT	€	€	€	€	€	€	F	H	I	I
V[çã	€	€	€	€	€	€	F	í	í	í
Ö[] :ã ÁV[çã	F	€	F	€	€	€	G	GF	GH	G
Ö[] : & @ Á	F€€	€	Á	€	€	Á	í È	JFÈH	Á	Á
V[çã Á	I ÈG	€	I ÈG	€	€	€	í ÈH	í í È	Jí È	

UããÖÁã ^	Uã: ÁUÖE^ ^ ^ U[^ c@ [^] á			U&ã ÁÖ[^ ÇããáÁÖã cá[^] á Y ^ ◦ cá[^] á			U&ã ÁÖ[^ ÇããáÁÖã cá[^] á Öã cá[^] á			Q cÁV[çã
	Š^c	Üã @	Ö[] ÈV[çã	V@~	Üã @	Ö[] ÈV[çã	Š^c	V@~	Ö[] ÈV[çã	
Uãã ÁV[^ : Ö[] :ã ÁV[{ ÁE KEEÁUT ÁE ÁE KÍ ÁUT ÁE Uãã ÁV[- ÁE										
Uãã ÁV[^ : ÁV[Ö[] :ã ÁV[: ^ & @] ÁÖ^ á : Áã ÁE KEEÁUT										
€ KEEÁUT	€	€	€	€	€	€	1	I	í	í
€ KÍ ÁUT	€	€	€	€	€	€	€	6	6	í
€ KKEÁUT	1	€	1	€	€	€	€	í	í	7
€ KÍ ÁUT	€	€	€	€	€	€	€	€	€	€
V[çã K[] ^	F	€	F	€	€	€	F	FÍ	FÍ	FÍ
Á ÁÖ[] ÈV[çã	F€€	€	Á	€	€	Á	í È	Jí È	Á	Á
UPØ	ÈI €	È€€	ÈI €	È€€€	È€€€	È€€€	ÈI €	Èíí	È€	ÈI H

Ö[] • ÁV[] á á ÁQ&É
 UUÁÖ[] cÁFI
 Ö[] á á ÖÖÁGII
 QI FÖG i È G i

Öá Á -Á[] * Á^áá@
 ÞÖUÁUá:ÁU/Ö^ ^
 ÖEY KÁU&á ÁÖ[] ^çááÁÖæ cá[] á
 Y ^áá@:KÁU } }

Öá Á á ^ KÖÖÓUΩ ÖÖÓÚT
 Uá ÁÖ[] á ^ KÉÉÉÉÉÉF
 Üæ Öá ^ KÁ FÖEFG
 Üæ ^ Á ^ KÁ

Ö[] • ÁV[] á á ÖÖ[] á ÁV[] & •

Üæ ÖÁ/á ^	Uá:ÁU/Ö^ ^ U[] cÁ[] á			U&á ÁÖ[] ^çááÁÖæ cá[] á Y ^• cá[] á			U&á ÁÖ[] ^çááÁÖæ cá[] á Öæ cá[] á			Q ÖÁV[] çá
	Š^c	Üä @	Ö[] ÈV[] çá	V@~	Üä @	Ö[] ÈV[] çá	Š^c	V@~	Ö[] ÈV[] çá	
É KÉÁÚT	H	€	H	€	€	€	G	I I	I I	I J
É KÍ ÁÚT	H	€	H	€	€	€	F	I F	I G	I I
É KÉÁÚT	H	€	H	€	€	€	€	FJ	FJ	GG
É KÍ ÁÚT	G	€	G	€	€	€	€	i	i	FÉ
V[] çá	FF	€	FF	€	€	€	H	FGG	FG	FH
É KÉÁÚT	G	€	G	€	€	€	€	i	i	J
É KÍ ÁÚT	€	€	€	€	€	€	€	FÍ	FÍ	FÍ
É KÉÁÚT	€	€	€	€	€	€	€	FF	FF	FF
É KÍ ÁÚT	€	€	€	€	€	€	€	FF	FF	FF
V[] çá	G	€	G	€	€	€	€	I I	I I	I I
Ö[] á ÁV[] çá	FH	€	FH	€	€	€	H	FÍ I	FÍ €	FÍ H
Ö[] :&ÖÁ	F€€	€	Á	€	€	Á	FÈ	JÍ ÈG	Á	Á
V[] çá	I È	€	I È	€	€	€	FÈ	JFÈH	JGÈ	

Üæ ÖÁ/á ^	Uá:ÁU/Ö^ ^ U[] cÁ[] á			U&á ÁÖ[] ^çááÁÖæ cá[] á Y ^• cá[] á			U&á ÁÖ[] ^çááÁÖæ cá[] á Öæ cá[] á			Q ÖÁV[] çá
	Š^c	Üä @	Ö[] ÈV[] çá	V@~	Üä @	Ö[] ÈV[] çá	Š^c	V@~	Ö[] ÈV[] çá	
Üá ÁV[] :ÁÖ[] á ÁÖ[] { ÁÉ KÉÁÚT ÁÉ KÍ ÁÚT ÁU^á ÁÁ -Á										
Üá ÁV[] :Á[] ÁÖ[] cá ÁÖ[] • ^á } ÁÖ^ á • ÁÁÉ KÉÁÚT										
É KÉÁÚT	3	€	3	€	€	€	2	54	56	59
É KÍ ÁÚT	H	€	H	€	€	€	F	I F	I G	I I
É KÉÁÚT	H	€	H	€	€	€	€	FJ	FJ	GG
É KÍ ÁÚT	G	€	G	€	€	€	€	i	i	FÉ
V[] çáK[] ^	FF	€	FF	€	€	€	H	FGG	FG	FH
Á Ö[] ÈV[] çá	F€€	€	Á	€	€	Á	GÈ	JÍ È	Á	Á
UPØ	ÈFÍ	È€€	ÈFÍ	È€€	È€€	È€€	ÈÍ I	ÈÍ I	ÈÍ I	ÈÍ I

