

TO: HARBOR DEPARTMENT PURCHASING OFFICE
500 Pier "A" Street
Berth 161
Wilmington, CA 90744

BID NO. F-1035 Page 1
Show this number on envelope

Contract No. 39877

1. COMPLETE CONTRACT

This entire Bid Request shall become the contract upon its execution by the Executive Director on behalf of the Harbor Department of the City of Los Angeles. The complete contract shall consist of the entire Bid (including Specifications), this page, terms and conditions, any addendums, and when required, CONTRACTOR'S BOND. Contractor will be provided with a copy of the executed contract.

2. GOODS AND SERVICES TO BE PROVIDED BY THE CONTRACTOR

The Contractor agrees, upon acceptance of this offer by the City, to furnish the goods and services herein specified according to the terms and conditions as set forth herein.

3. AMOUNT TO BE PAID

The City agrees to pay the contractor for the goods or services in the manner described in the paragraph entitled "PAYMENTS" according to the terms and conditions. Unless otherwise indicated by the Bidder, remittance by the City for goods or services will be made to the address below.

4. CHOICE OF ALTERNATIVE PROVISIONS; OPTIONS; NOTIFICATION

When alternative provisions are requested, or options are offered, the contractor will be notified as to which provision, or option, is being accepted when notification is sent that the Contractor is the successful bidder.

5. DECLARATION OF NON-COLLUSION

The undersigned certifies (or declares) under penalty of perjury that this bid is genuine and not sham or collusive, or made in the interest or on behalf of any person, firm, or corporation not herein named; that the bidder has not directly or indirectly induced or solicited any other bidder to put up a sham bid, or any other person, firm or corporation to refrain from bidding, and that the bidder has not in any manner sought by collusion to secure any advantage over other bidders.

6. LEGAL JUSTIFICATION

This agreement shall be deemed entered into in Los Angeles, California, and shall be governed and construed in accordance with the laws of the State of California.

EXECUTED AT: Cleveland, OH ON THE 7th DAY OF February, 2019
City, State Date Month Year

BIDDER MUST COMPLETE AND SIGN BELOW:



Firm Name Cleveland Track Material, Inc.
Phone 216 641 4000 Fax 216 441 7507
Address 6600 Bessemer Ave Cleveland OH 44127
Street City State Zip

Signature  Printed Name Eliseo Bandala Printed Title CEO
Signature Printed Name Printed Title

(Approved Corporate Signature Methods) (AFFIX CORPORATE SEAL HERE)

- a) **Two signatures:** One by Chairman of Board of Directors, President, or a Vice-President **AND** one by Secretary, Assistant Secretary, Chief Financial Officer or an Assistant Treasurer.
- b) **One signature:** By corporate designated individual together with properly attested resolution of Board of Directors authorizing person to sign.

NOTARIZATION: Bids executed outside the State of California must be sworn to and notarized below.

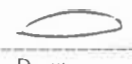
<p>County of <u>Cuyahoga</u> State of <u>Ohio</u> S.S. Subscribed and sworn this date <u>February 7th</u>, 2019  Notary Seal SANDRA REIK NOTARY PUBLIC, STATE OF OHIO</p>	<p>In witness whereof the Board of Harbor Commissioners of the City of Los Angeles has caused this contract to be executed by the Executive Director of the Harbor Department of said City and said Contractor has executed this contract the day and year written below. By _____ Executive Director Harbor Department Date _____</p>	<p>Approved as to form and legality <u>3-1</u>, 2019 City Attorney BY  Deputy </p>
---	--	--

FORMAL REQUEST FOR BID

CITY OF LOS ANGELES
HARBOR DEPARTMENT

BID NO. F-1035

(SHOW THIS NUMBER ON ENVELOPE)

BID DUE BEFORE 2:00 PM ON: Tuesday, January 29, 2019

State Make, Model Quoting: _____
Prices to include all charges and fees excluding sales tax.

2. 2 EA Each \$ 66,700.- \$ 133,400.-
Each Three Piece **LH** Joint which consists of the following:
1 Movable Point LH (99425-LB)
1 Rocker LH (99395-LB)
1 Fixed Point LH (99423-LB)
1 Locking Pin (99367A)
Balance of necessary Hardware and Pads for Assembly
Weight per Joint: **4,704 #**

Reference Drawings:

- Drawing A-83126SH6
- Drawing B-83126SH3
- Drawing B-83126SH4
- Drawing B-83126SH5
- Drawing C-83126SH1
- Drawing C-83127SH1

State Make, Model Quoting: _____
Prices to include all charges and fees excluding sales tax.

BIDDER'S INSTRUCTIONS

REQUEST FOR QUOTATION BIDDER RESPONSIVENESS. In order to be responsive, bidders shall complete and return all Quotation documents requested by the Port, including addenda, specifications, drawings and all forms.

It shall be the bidder's responsibility to provide one (1) original and one (1) copy of the completed Quotation documents. The original and all copies shall include all quotation documents requested by the Port, including addenda, specifications, drawings and all forms.

The Purchasing Agent may deem a bidder non-responsive if the bidder fails to provide all Quotation documents requested by the Port at the Quotation closing date and time.

ADDENDUMS. From time to time, the Harbor Department may deem it necessary to issue an addendum(s) to modify or cancel a Bid Request. Such addendum(s) will be available on the Port of Los Angeles internet website – www.portoflosangeles.org and the Los Angeles Business Assistance Virtual Network website – www.labavn.org. It is the responsibility of the bidder to be aware of and respond to any such addendum(s) before the deadline of the applicable bid request. Failure to do so may deem the bid non-responsive.

BID SUBMITTAL TIMELINESS

Bidders solely are responsible for the timeliness of their submittals. As such, bidders are cautioned to budget adequate time to ensure that their bids are delivered at the location designated at or before the deadline set forth above. Bidders are cautioned that matters including, but not limited to, traffic congestion, security measures and/or events in or around the Harbor Department, may lengthen the amount of time

FORMAL REQUEST FOR BID

CITY OF LOS ANGELES
HARBOR DEPARTMENT

BID NO. F-1035
(SHOW THIS NUMBER ON ENVELOPE)

BID DUE BEFORE 2:00 PM ON: Tuesday, January 29, 2019

necessary to deliver the bid, whether the bid is submitted in person or by mail.

AWARD. The Harbor Department reserves the right to reject any or all Bids, award Bid as a whole, split award or delete line items, as it may deem necessary, unless otherwise stated herein.

SUPPLIER CONTACT INFORMATION:

Contact Person: Bruce Buzzard

Title: Estimator

Telephone No.: 216 641 4000

Fax No.: 216 441 7507

E-Mail Address: bruce.buzzard@vossloh.com

24 Hour Contact No.: _____

CONTRACTUAL TERMS SECTION

AUTHORIZED DISTRIBUTOR/DEALER:

Bidder must indicate if it is an authorized factory distributor/dealer for the manufacturer being quoted (please initial).

Yes: No:

If bidder is not an authorized distributor/dealer, the bidder shall submit with its Quotation a formal Letter of Certification from the manufacturer, stating that the manufacturer will honor any warranty claims by the City for equipment, parts, and/or materials provided by the bidder.

The manufacturer will be responsible for any default of the supplier that is not corrected by the supplier in a timely and efficient manner. This responsibility includes replacing incorrect or defective parts, trouble shooting, and correcting problems that are traceable to the manufacturer.

ADDITIONAL QUANTITIES. The Harbor Department desires the option to purchase additional quantities of above item(s) at the same prices, terms and conditions, providing that the total of any of the additional quantities does not exceed the total for that item, and providing that the Harbor Department exercise the option before: 5-12-19

NEW AND UNUSED. The equipment furnished shall be new and unused, current model.

MATERIAL, EQUIPMENT, SERVICE

SPECIFICATION CHANGES. If provisions of the Specifications preclude bidder from submitting bid, he may request in writing that the specifications be modified. Such request must be received by the Purchasing Officer at least five (5) working days before bid opening date. All bidders will be notified by Addendum of any approved changes in the specifications.

FORMAL REQUEST FOR BID

CITY OF LOS ANGELES
HARBOR DEPARTMENT

BID NO. F-1035
(SHOW THIS NUMBER ON ENVELOPE)

BID DUE BEFORE 2:00 PM ON: Tuesday, January 29, 2019

DEVIATION FROM SPECIFICATIONS. Specifications contained herein are to describe the construction, design, size, and quality of the desired product and are not intended to be restrictive to any particular product. If bidder proposes to furnish another product equal in quality and purpose, such bids will be considered as long as they materially comply with the specifications. Each deviation from the specifications must be stated in a letter, attached to bidder's submittal. Failure to do so may void bid

ILLUSTRATIVE AND TECHNICAL DATA. When quoting other than the specified brand or when no brand is indicated, Bidder must submit with bid, complete illustrative and technical data on materials or equipment proposed to be furnished. Failure to furnish such data may void bid.

SAFETY AND HEALTH REQUIREMENTS. All equipment, materials, procedures and services furnished and/or used by the Contractor shall comply with applicable current requirements of OSHA and CAL-OSHA. Contractor agrees to indemnify and hold harmless Los Angeles City, The Harbor Department, and agents, officers and employees thereof, for all damages assessed against them as a result of Contractor's failure to comply with said safety and health requirements.

SAFETY APPROVAL. Electrical items listed herein shall have UNDERWRITER'S LABORATORY OR LOS ANGELES CITY ELECTRICAL TESTING LABORATORY approval and meet all current OSHA and CAL-OSHA requirements, where applicable.

WORKMANSHIP AND MATERIALS. All materials, parts and equipment furnished by the Contractor for the Work shall be new, high grade and free from defects. Materials and work quality shall be subject to the City of Los Angeles Harbor Department Project Manager (PM) approval.

TECHNICAL CORRECTIONS. The Executive Director or designee is authorized to make minor technical corrections or clarifications in order to effectuate the intent of this contract/bid.

DELIVERY CLAUSES

DELIVERY POINT. Prices to include all delivery charges, F.O.B. the Harbor Department to:
PHL – Rail Yard
300 Water Street
Wilmington, CA 90744

DELIVERY. Delivery is desired within five **(30) days** after vendor receives order. If this time cannot be met, show in the space provided on the Bid Sheet the best delivery time you can guarantee. The Harbor Department reserves the right to make award based on delivery time quoted.

NOTIFICATION. The vendor shall notify **Chuck Smith**, C & M Division of the Port of Los Angeles at (310) 732- 3688 not less than three (3) days in advance that the equipment is ready for delivery.

FINANCIAL CLAUSES

BILLING DISCOUNT TERMS. Billing Discount terms offering 20 days or more will be considered in making evaluation for award.

FORMAL REQUEST FOR BID

CITY OF LOS ANGELES
HARBOR DEPARTMENT

BID NO. F-1035
(SHOW THIS NUMBER ON ENVELOPE)

BID DUE BEFORE 2:00 PM ON: Tuesday, January 29, 2019

SALES TAXES. Do not include Sales Taxes in your Bid. Sales Taxes will be added at time of order.

SALES TAX PERMIT. Vendor's California State Board of Equalization Permit No. required to collect California State Sales Tax. Permit Number: _____.

FEDERAL EXCISE TAX. The City of Los Angeles Harbor Department is exempt from payment of Federal Excise Taxes, and will furnish vendor with a Tax Exemption Certificate. PRICING NOT TO INCLUDE ANY FEDERAL EXCISE TAX.

VENDOR PAYMENT. Please note. Vendor name and address must be submitted exactly as it will appear on the invoice. If invoice remit to (remittance) name and address are different from the bid name and address, please indicate:

REMIT TO: NAME: Cleveland Track Material, Inc.

ADDRESS: P.O. Box 71237

Cleveland, OH 44191

Invoices submitted for payment where the invoice name and address does not match the name as it appears on the purchase order or as indicated in the space above, will not be processed and will be returned to the vendor.

GENERAL CLAUSES – LAW, CHARTER, ADMINISTRATIVE CODE

COMPLIANCE WITH LAWS. Vendor shall comply with all applicable Ordinances, laws, Rules and Regulations of the City and of any County, State or Federal Government, or subdivision thereof.

DEFAULT BY SUPPLIER. In case of default by Vendor, the City reserves the right to procure the articles or services from other sources and to hold the vendor responsible for any excess costs occasioned to the City thereby.

ENVIRONMENTAL MANAGEMENT SYSTEM

The Los Angeles Harbor Department (Port) is committed to managing resources and conducting Port development and operations in both an environmentally and fiscally responsible manner. The Port will strive to improve the quality of life and minimize the impacts of its development and operations on the environment and surrounding communities through the continuous improvement of its environmental performance and the implementation of pollution prevention measures, in a feasible and cost effective manner that is consistent with the Port's overall mission and goals, as well as with those of its customers and the community. To ensure this policy is successfully implemented the Port will develop an environmental management program that will:

1. Ensure this environmental policy is communicated to Port staff, its customers, and the community;
2. Ensure compliance with all applicable environmental laws and regulations;
3. Ensure environmental considerations are included in planning, property, financial, developmental, and operational decisions, including feasible and cost effective options for exceeding applicable requirements;

FORMAL REQUEST FOR BID

CITY OF LOS ANGELES
HARBOR DEPARTMENT

BID NO. F-1035

(SHOW THIS NUMBER ON ENVELOPE)

BID DUE BEFORE 2:00 PM ON: Tuesday, January 29, 2019

4. Define and establish environmental objectives, targets, and best management practices and monitor performance;
5. Ensure the Port maintains a Customer Outreach Program to address common environmental issues; and
6. Fulfill the responsibilities of each generation as trustee of the environment for succeeding generations through environmental awareness and communication with employees, customers, regulatory agencies, and neighboring communities.

The Port is committed to the spirit and intent of this policy and the laws, rules and regulations, which give it foundation.

LOCAL BUSINESS PREFERENCE PROGRAM

The Harbor Department is committed to maximizing opportunities for local and regional businesses, as well as encouraging local and regional businesses to locate and operate within the Southern California region. It is the policy of the Harbor Department to support an increase in local and regional jobs. The Harbor Department's Local Business Preference Program (LBPP) aims to benefit the Southern California region by increasing jobs and expenditures within the local and regional private sector.

Vendors who qualify as a Local Business Enterprise (LBE) will receive an 8% preference on any bid for goods, materials, supplies, and related services valued in excess of \$150,000. The preference will be applied by calculating the bidder's price at 8% less than the quoted price. The Harbor Department will use the applied preference for bid tabulation only. Actual amount paid to the lowest bidder will be the price quoted by the lowest bidder meeting specifications.

The Harbor Department defines a LBE as:

- (a) A business headquartered within Los Angeles, Orange, Riverside, San Bernardino, or Ventura Counties. Headquartered shall mean that the business physically conducts and manages all of its operations from a location in the above-named counties; or
- (b) A business that has at least 50 full-time employees, or 25 full-time employees for specialty marine contracting firms, working in Los Angeles, Orange, Riverside, San Bernardino, or Ventura Counties.

In order for Harbor Department staff to determine the appropriate LBE preference, Bidder shall complete, sign, notarize and submit the attached Affidavit and Bidder Description Form. The Affidavit and Bidder Description Form will signify the LBE status of the Bidder and subcontractors.

In the event of Bidder's noncompliance during the performance of the Contract, Bidder shall be considered in material breach of contract. In addition to any other remedy available to City under this Contract or by operation of law, the City may withhold invoice payments to Bidder until noncompliance is corrected, and assess the costs of City's audit of books and records of Bidder and its subcontractors. In the event the Bidder falsifies or misrepresents information contained in any form or other willful noncompliance as determined by City, City may disqualify the Bidder from participation in City contracts for a period of up to five (5) years.

FORMAL REQUEST FOR BID

CITY OF LOS ANGELES
HARBOR DEPARTMENT

BID NO. F-1035

(SHOW THIS NUMBER ON ENVELOPE)

BID DUE BEFORE 2:00 PM ON: Tuesday, January 29, 2019

MINORITY, WOMEN, AND OTHER BUSINESS ENTERPRISE (MBE/WBE/OBE). It is the policy of the Los Angeles Harbor Department to provide minority (MBE), women (WBE) and all other (OBE) business enterprises an equal opportunity to participate in the performance of all Harbor Department contracts. Such opportunities have resulted in combined M/WBE participation of over 20%. Bidders are encouraged to continue assisting the Department in implementing this policy by taking all reasonable steps to ensure that all available business enterprises have an equal opportunity to compete for and participate in Department contracts. All bidders are encouraged to reach out to M/W/OBEs when opportunities are available.

EQUAL BENEFITS POLICY. The Board of Harbor Commissioner of the City of Los Angeles adopted Resolution No. 6328 on January 12, 2005, agreeing to adopt the provisions of Los Angeles City Ordinance 172,908, as amended, relating to Equal Benefits (Section 10.8.2 et seq. of the Los Angeles Administrative Code) as a policy of the Harbor Department. Bidder shall comply with the policy whenever applicable. Violation of the policy shall entitle the City to terminate any agreement with Bidder and pursue any or all other legal remedies that may be available.

EQUAL BENEFITS POLICY. The Board of Harbor Commissioner of the City of Los Angeles adopted Resolution No. 6328 on January 12, 2005, agreeing to adopt the provisions of Los Angeles City Ordinance 172,908, as amended, relating to Equal Benefits (Section 10.8.2 et seq. of the Los Angeles Administrative Code) as a policy of the Harbor Department. Bidder shall comply with the policy whenever applicable. Violation of the policy shall entitle the City to terminate any agreement with Bidder and pursue any or all other legal remedies that may be available.

In order for Harbor Department staff to determine the appropriate LBE preference, Bidder shall complete, sign, notarize and submit the attached Affidavit and Bidder Description Form. The Affidavit and Bidder Description Form will signify the LBE status of the Bidder and subcontractors.

In the event of Bidder's noncompliance during the performance of the Contract, Bidder shall be considered in material breach of contract. In addition to any other remedy available to City under this Contract or by operation of law, the City may withhold invoice payments to Bidder until noncompliance is corrected, and assess the costs of City's audit of books and records of Bidder and its subcontractors. In the event the Bidder falsifies or misrepresents information contained in any form or other willful noncompliance as determined by City, City may disqualify the Bidder from participation in City contracts for a period of up to five (5) years.

BUSINESS TAX REGISTRATION CERTIFICATE (BTRC). In accordance with the City of Los Angeles Municipal Code, a Business Tax Registration Certificate may be required of persons engaged in business activity within the City. **The Office of Finance, Tax and Permit Division, (844) 663-4411**, has sole authority in determining a firm's tax requirements and in issuing Business Tax Registration Certificates or Business Tax Exemption Numbers. Accordingly, firm's current Business Tax Registration Certificate or Business Tax Exemption Number must be clearly shown on all invoices submitted for payment. Bidder, in submitting this bid, acknowledges and accepts the above requirements and recognizes that no invoice will be processed for payment without inclusion of the Business Tax Registration Certificate or Business Tax Exemption Number.

BTRC/BTRC Exemption Number: 3057224 (required)

TAXPAYER IDENTIFICATION NUMBER. Contractor declares that it has an authorized Taxpayer Identification Number (TIN), which must be indicated on all invoices. No payments will be made under this

FORMAL REQUEST FOR BID

**CITY OF LOS ANGELES
HARBOR DEPARTMENT**

BID NO. F-1035
(SHOW THIS NUMBER ON ENVELOPE)

BID DUE BEFORE 2:00 PM ON: Tuesday, January 29, 2019

agreement without a valid TIN number.

SPECIAL NOTE. If you are not bidding, please state reason for not bidding and return bid to the Purchasing Office:

FORMAL REQUEST FOR BID

CITY OF LOS ANGELES
HARBOR DEPARTMENT

BID NO. F-1035
(SHOW THIS NUMBER ON ENVELOPE)

BID DUE BEFORE 2:00 PM ON: Tuesday, January 29, 2019

GENERAL CONDITIONS READ CAREFULLY

1. **FORM OF BID AND SIGNATURE.** The Bid must be made on this form only, and is limited to the Terms and Conditions contained herein, unless expressly agreed otherwise in writing by the City. No telephonic or facsimile bid is acceptable, unless otherwise indicated. Bid should be enclosed in a sealed envelope, showing the Bid No. in the lower left corner, and addressed to the Port of Los Angeles Contracts and Purchasing Division, 500 Pier "A" Street, Wilmington, CA 90744. Bids must be signed with the firm's corporate name or DBA and by a responsible officer or authorized employee. In case of error in extension of prices, unit price will govern. All prices must be firm unless the specification provides for adjustment.

The Harbor Department will not be responsible for services, materials, or supplies furnished without prior authorization from the Director of Contracts and Purchasing.

This contract must not be assigned or transferred to anyone without the written approval of the Director of Contracts and Purchasing.

Discount period to be computed from date of receipt of invoice, or complete acceptance of goods or services, whichever is the later date.

In case of delay of payment beyond 30 days after acceptance of goods or services or date of invoice, whichever is later, please write the Harbor Department Accounting Section giving the contract number, stating to which division and on what date delivery was made.

Harbor Department may pay on partial deliveries, but right is reserved by the Director of Contracts and Purchasing to require complete delivery before payment.
2. **TAXES:** Do not include any Sales or Federal Excise Tax in prices unless the specifications specifically require that they be included. Sales tax will be added by the City at time of award. The City will furnish Federal Excise Tax Exemption Certificate to Supplier. Any other taxes must be included in bid prices.
3. **SPECIFICATION CHANGES** Vendor may request in writing that specifications be modified if its provisions restrict vendor from bidding. Such request must be received by the Director of Purchasing at least five (5) working days before bid opening date. All vendors will be notified by Addendum of any approved changes in the specifications.
4. **BRAND NAMES AND SPECIFICATIONS.** The detailed specifications and/or brand name references are descriptive and indicate quality, design, and construction of items required. Offers will be considered to supply articles substantially the same as those described therein but with minor variations. Vendor must describe variations in their Bid.
5. **AWARD OF CONTRACT.** Bid shall be subject to acceptance by the City for a period of three (3) months unless a lesser period is prescribed in the quotation by the vendor. The City may make combined award of all items complete to one vendor or may award separate items to various vendors. Vendors may submit alternate prices, a lump sum or a discount conditional on receiving an award for two or more items. The right is reserved to reject any, or all, bids and to waive informality in bids.
6. **PURCHASE AGREEMENT.** A copy of the Bid, Specifications and General Conditions will remain on file in the Purchasing Office. All material or services supplied by the Contractor shall conform to the applicable requirements of the City Charter, City Ordinances, and all applicable State and Federal Laws, as well as conforming to the Specifications, Terms and Conditions contained herein.
7. **PRICE GUARANTEE.** If during the term of any agreement awarded pursuant to this Bid, the supplier sells the same materials or services under similar quantity and delivery conditions, at prices below those stated herein, such lower prices are to immediately be extended to the City.
8. **DEFAULT BY SUPPLIER.** In case of default by supplier, the City reserves the right to procure the articles or services from other sources and to hold the supplier responsible for any excess costs incurred by the City.
9. **DELIVERY:** If delivery of the commodity or service cannot be made exactly as specified and at the price shown, notify the Director of Contracts and Purchasing immediately. Do not make delivery without his approval. Any correspondence, other than invoices, relating to this order must be sent to the Director of Contracts and Purchasing.
10. **INSPECTION:** All materials furnished on this order will be subject to test and inspection and, if rejected, will be held subject to order of shipper and subject to accrued charges.
11. **INVOICING:** The point of free delivery, terms, contract number, name and address of department must appear on all invoices.

All materials must be marked and tagged with the Contract number and be accompanied by packing list in detail. Material must be packed and shipped in conformity with tariff or classification requirements.

Prices on the contract include delivery to the division within building unless otherwise specified on the contract.

Prepaid charges for transportation must be accompanied by original expense bill marked paid and is not subject to transportation tax, due to the exemption permitted municipalities as indicated.

Materials shall be listed separately on invoices covering repairs or installation service.
12. **TIME AND MATERIALS WITH NO FIXED FEES: ALL INVOICES WITH PAYMENTS FOR TIME AND MATERIALS MUST BE SUPPORTED / BACKED UP BY TIME SHEETS.**

NOTE: THOSE INVOICES WITH FIXED FEE RATES DO NOT REQUIRE TIME SHEETS.
13. **CITY OF LOS ANGELES MUNICIPAL CODE:** All items must meet the requirements of the City of Los Angeles Municipal Code.
14. **PAYMENTS.** Payment terms are NET 30 days unless vendor quotes otherwise. Cash discounts allowing less than 20 days or 20th Proxima will not be considered by the City when evaluating Bids. All Cash Discounts are computed from the date of delivery in full or completion and acceptance of the work or material, or from date of receipt of invoice, whichever is latest. Partial payments may be made by the City on delivery and acceptance of goods and on receipt of vendor's invoice. Invoices must be submitted as specified on the Purchase Order or Notice to Proceed.
15. **ASSIGNMENT.** The supplier shall not assign or transfer by operation of law any obligation without the prior written consent of the Director of Contracts and Purchasing.
16. **NONDISCRIMINATION.** During the performance of this contract, the contractor shall not discriminate in employment practices against any employee or applicant for employment because of the employee's race, religion, national origin, ancestry, sex, sexual orientation, age, disability, marital status, domestic partner status or medical condition, in accordance with L.A. Admin. Code Sections 10.8 to 10.13, whose provisions are incorporated herein. All subcontracts awarded under any such contract shall contain a like nondiscrimination provision.
17. **SAFETY APPROVAL.** Articles supplied under this contract will not be accepted unless they comply with current safety regulations of the City Department of Building and Safety, U.L., the Safety Orders of the California Division of Occupation Safety and Health (CalOSHA) and OSHA requirements.
18. **PREVAILING WAGES.** Where labor is required for public work as a part of this contract, pursuant to the provisions of the Labor Code of the State of California, contractor shall pay no less than the general prevailing wages for the area as determined by the Director of the Department of Industrial Relations, State of California. Copy of wage schedule is obtainable from the Office of the Board of Public Works, City Hall, Los Angeles.
19. **CONTRACTOR'S LIABILITY.** The contractor agrees to, at all times, relieve, protect, save harmless, and fully indemnify the City of Los Angeles, its officers, agents and employees from any and all liability whatsoever that may arise or be claimed by reason of any acts of said contractor, contractor's employees and agents, in connection with the work to be performed under the contract.
20. **PATENT RIGHTS.** The person, firm, or corporation, upon whom this order is drawn, does, in case the materials or supplies to be furnished are covered wholly or in part by U.S. Letters Patent, by the acceptance of this order agrees to indemnify and hold the City of Los Angeles harmless from any and all injuries or damage which the City may sustain by reason of the sale to or use by it of such materials or supplies and arising out of the alleged or actual infringement of said letters patent.

FORMAL REQUEST FOR BID

**CITY OF LOS ANGELES
HARBOR DEPARTMENT**

BID NO. F-1035

(SHOW THIS NUMBER ON ENVELOPE)

BID DUE BEFORE 2:00 PM ON: Tuesday, January 29, 2019

21. **LEGAL JUSTIFICATION.** This agreement shall be deemed entered into in Los Angeles, California, and shall be governed and construed in accordance with the laws of the State of California.
22. **TERMINATION FOR NON-APPROPRIATION.** The Harbor Department of the City of Los Angeles' (City's) obligation to pay any amount hereunder, for any City fiscal year after the current fiscal year is contingent upon City's appropriation of funds for that purpose. The City's fiscal year ends on June 30th of each calendar year. Accordingly, anything to the contrary notwithstanding, the City may terminate this contract and future monetary obligations hereunder as of the end of any fiscal year.
23. **CANCELLATION.** The contract may be terminated in whole or in part by the Harbor Department of the City of Los Angeles (City) for its convenience, without penalty, provided that the Vendor is given not less than 30 days written notice (delivered by certified mail, return receipt requested) of the intent to terminate. The City will pay for that portion of the orders fulfilled or work performed. The City has the right to cancel the contract for cause at any time.

THE END

No. 285 Rev. 07/15-116



City Ethics Commission
 200 N Spring Street
 City Hall — 24th Floor
 Los Angeles, CA 90012
 Mail Stop 129
 (213) 978-1960

Prohibited Contributors (Bidders)

CEC Form 55

This form must be completed in its entirety and submitted to the awarding authority with your bid or proposal for the contract noted below. A bid or proposal that does not include a completed form will be deemed nonresponsive. Please write legibly.

Original filing Amended filing (original signed on _____; last amendment signed on _____)

Bid/Contract/BAVN Number (or other identifying information if no number):

F-1035

Date Bid Submitted:

2-12-19

Description of Contract:

Badger Avenue Bridge Miter Joints

Awarding Authority (Department):

Part of Los Angeles

BIDDER

Name: CLEVELAND TRACK MATERIAL, INC.

Address: 6600 Bessemer Avenue
Cleveland, Ohio 44127

Email (optional): _____ Phone: 216 641 4000

State Contractor ID: N/A

State ID must be disclosed for identification purposes, even if not performing work on this contract under that license. If the bidder does not have a state contractor ID, indicate "not applicable".

PRINCIPALS

Please identify the names and titles of all principals (attach additional sheets if necessary). Principals include a bidder's board chair, president, chief executive officer, chief operating officer, and individuals who serve in the functional equivalent of one or more of those positions. Principals also include individuals who hold an ownership interest in the bidder of at least 20 percent and employees of the bidder who are authorized by the bid or proposal to represent the bidder before the City.

Name: Eliseo Bandala Title: CEO

Address: 6600 Bessemer Ave Cleveland, OH 44127

Name: Jens Finklel Title: COO

Address: 6600 Bessemer Ave Cleveland, OH 44127

Name: Michael Zatorsky Title: Controller

Address: 5662A Leesport Ave Reading, PA

Name: _____ Title: _____

Address: _____

_____ additional sheets are attached. Bidder is an individual and no other principals exist.



City Ethics Commission
 200 N Spring Street
 City Hall — 24th Floor
 Los Angeles, CA 90012
 Mail Stop 129
 (213) 978-1960

Prohibited Contributors (Bidders)

CEC Form 55

SUBCONTRACTORS

Please identify all subcontractors whose subcontracts are worth \$100,000 or more (attach additional sheets if necessary). If the subcontractor has a state contractor license, the ID must be disclosed for identification purposes, even if the subcontractor is not performing work on this contract under that license.

Subcontractor: _____
 Address: _____
 State Contractor ID (for identification purposes; if none, indicate "not applicable"): _____

Subcontractor: _____
 Address: _____
 State Contractor ID (for identification purposes; if none, indicate "not applicable"): _____

Subcontractor: _____
 Address: _____
 State Contractor ID (for identification purposes; if none, indicate "not applicable"): _____

Subcontractor: _____
 Address: _____
 State Contractor ID (for identification purposes; if none, indicate "not applicable"): _____

Subcontractor: _____
 Address: _____
 State Contractor ID (for identification purposes; if none, indicate "not applicable"): _____

Subcontractor: _____
 Address: _____
 State Contractor ID (for identification purposes; if none, indicate "not applicable"): _____

Subcontractor: _____
 Address: _____
 State Contractor ID (for identification purposes; if none, indicate "not applicable"): _____

Subcontractor: _____
 Address: _____
 State Contractor ID (for identification purposes; if none, indicate "not applicable"): _____

Subcontractor: _____
 Address: _____
 State Contractor ID (for identification purposes; if none, indicate "not applicable"): _____

_____ additional sheets are attached.

Bidder has no subcontractors on this bid or proposal whose subcontracts are worth \$100,000 or more.



City Ethics Commission
 200 N Spring Street
 City Hall — 24th Floor
 Los Angeles, CA 90012
 Mail Stop 129
 (213) 978-1960

Prohibited Contributors (Bidders) CEC Form 55

PRINCIPALS OF SUBCONTRACTORS

Please identify the names and titles of all principals for each subcontractor identified on page 2 (attach additional sheets if necessary). Principals include a subcontractor's board chair, president, chief executive officer, chief operating officer, and individuals who serve in the functional equivalent of one or more of those positions. Principals also include individuals who hold an ownership interest in the subcontractor of at least 20 percent and employees of the subcontractor who are authorized by the bid or proposal to represent the subcontractor before the City.

Name: _____ Title: _____

Address: _____

Subcontractor: _____

Name: _____ Title: _____

Address: _____

Subcontractor: _____

Name: _____ Title: _____

Address: _____

Subcontractor: _____

Name: _____ Title: _____

Address: _____

Subcontractor: _____

Name: _____ Title: _____

Address: _____

Subcontractor: _____

Of the subcontractors identified on page 2, the following are individuals and no other principals exist (attach additional sheets if necessary):

Subcontractor: _____

Subcontractor: _____

_____ additional sheets are attached.

Bidder has no subcontractors on this bid or proposal whose subcontracts are worth \$100,000 or more.

CERTIFICATION

I certify that I understand, will comply with, and have notified my principals and subcontractors of the requirements and restrictions in Los Angeles City Charter section 470(c)(12) and any related ordinances. I understand that I must amend this form within ten business days if the information above changes. I certify under penalty of perjury under the laws of the City of Los Angeles and the state of California that the information provided above is true and complete.

Date: February 7, 2019

Signature: _____

Name: Elisav Bandala

Title: CEO

Under Los Angeles City Charter § 470(c)(12), this form must be submitted to the awarding authority with your bid or proposal. A bid or proposal that does not include a completed Form 55 will be deemed nonresponsive.

MOVEABLE BRIDGE MITER JOINTS

PART 1 – GENERAL

1.1 DESCRIPTION

The Work included in this Contract and as specified in this Section includes the detailed design of components, preparation of shop drawings, manufacture, testing, inspection, shop assembly, packaging, shipping, delivery, unloading and stacking of all replacements for Conley Joint materials and associated hardware for the provision of two sets of replacement joints, at the Port of Los Angeles, in the vicinity of Terminal Island.

Work Included:

- A. Work included in this Section encompasses work necessary for the design, manufacturing and fabrication of equivalently performing Moveable Bridge Miter Joints as specified in the General Drawing Notes.

1.2 REFERENCE SPECIFICATIONS

Except as modified herein, Moveable Bridge Miter Joints shall be designed, manufactured, tested, assembled, inspected, shipped, unloaded and stacked in accordance with requirements for equivalent special trackwork manganese castings as provided in the current American Railway Engineering and Maintenance of Way Association Portfolio of Trackwork Plans, and the current AREMA Manual for Railway Engineering.

1.3 DESIGN

A. General Information

1. The Conley Joints are presently installed on the POLA maintained Badger Bridge crossing Cerritos Channel, providing access for trains from the Port of Los Angeles and Long Beach accessing the Port of Los Angeles and the Port of Long Beach facilities on Terminal Island.
2. The types of Moveable Bridge Miter Joints to be included are replacements for proprietary Conley Joints presently installed on the Badger Bridge at the Port of Los Angeles.
3. Special trackwork (including existing Conley Joints) in the Port of Los Angeles area is subjected to heavy unit train traffic, mainly double stack intermodal trains. These trains contain cars with 125-ton tracks and axle loads of up to 42 tons.
4. The standard track gauge for the system is 4 feet 8-1/2 inches.
5. The standard running rail section is 136-10 rail.
6. Moveable Bridge Miter Joints on the Badger Bridge will be mounted on existing steel girders attached to the Bridge. The replacement Moveable Bridge Miter Joints must be designed and manufactured to exactly replace all or portions of existing Conley Joints, including bolt and locations.

B. Technical Requirements

1. The design of special trackwork in the Port of Los Angeles generally follows the AREMA practice.
2. Application of AREMA recommended practice at this location requires that the Moveable Miter Joints are to be directly bolted to steel girders mounted on the Badge Bridge.
3. All moveable Bridge Miter Joints shall be explosion-hardened manganese castings.

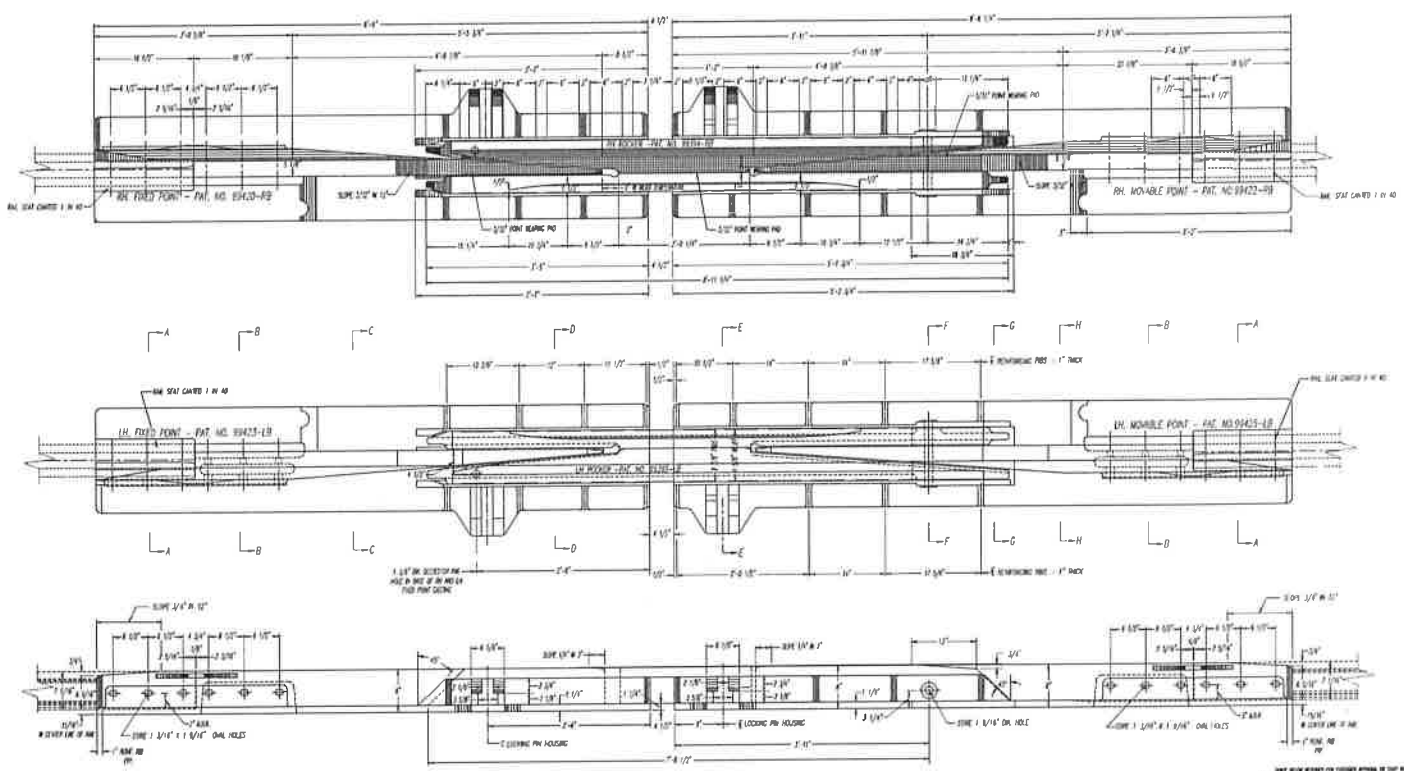

- MATERIAL REQUIRED FOR 1-PAIR OF BRIDGE JOINTS:**
- 1- BRIDGE CASTING FOR MOVABLE POINT - PART NO. 89422-02
 - 1- BRIDGE CASTING FOR ROLLER - PART NO. 89422-01
 - 1- BRIDGE CASTING FOR ROLLER - PART NO. 89422-03
 - 1- BRIDGE CASTING FOR ROLLER - PART NO. 89422-04
 - 1- BRIDGE CASTING FOR ROLLER - PART NO. 89422-05
 - 1- BRIDGE CASTING FOR ROLLER - PART NO. 89422-06
 - 1- BRIDGE CASTING FOR ROLLER - PART NO. 89422-07
 - 1- BRIDGE CASTING FOR ROLLER - PART NO. 89422-08
 - 1- BRIDGE CASTING FOR ROLLER - PART NO. 89422-09
 - 1- BRIDGE CASTING FOR ROLLER - PART NO. 89422-10
 - 1- BRIDGE CASTING FOR ROLLER - PART NO. 89422-11
 - 1- BRIDGE CASTING FOR ROLLER - PART NO. 89422-12
 - 1- BRIDGE CASTING FOR ROLLER - PART NO. 89422-13
 - 1- BRIDGE CASTING FOR ROLLER - PART NO. 89422-14
 - 1- BRIDGE CASTING FOR ROLLER - PART NO. 89422-15
 - 1- BRIDGE CASTING FOR ROLLER - PART NO. 89422-16
 - 1- BRIDGE CASTING FOR ROLLER - PART NO. 89422-17
 - 1- BRIDGE CASTING FOR ROLLER - PART NO. 89422-18
 - 1- BRIDGE CASTING FOR ROLLER - PART NO. 89422-19
 - 1- BRIDGE CASTING FOR ROLLER - PART NO. 89422-20

- CONSTRUCTION NOTES:**
- 1- CASTING TO BE IMPROVED PER AISC 360-10
 - 2- ALL WELDS SHALL BE PER AISC 360-10
 - 3- CASTING SHALL BE EXPLODED PER AREA PLAN 100-12 1027

- DETAIL NOTES:**
- 1- ALL SURFACES SHALL BE FINISHED TO A 1/8\"/>

- REFERENCE:**
- 1- BRIDGE CASTING FOR MOVABLE POINT - PART NO. 89422-02
 - 2- BRIDGE CASTING FOR ROLLER - PART NO. 89422-01
 - 3- BRIDGE CASTING FOR ROLLER - PART NO. 89422-03
 - 4- BRIDGE CASTING FOR ROLLER - PART NO. 89422-04
 - 5- BRIDGE CASTING FOR ROLLER - PART NO. 89422-05
 - 6- BRIDGE CASTING FOR ROLLER - PART NO. 89422-06
 - 7- BRIDGE CASTING FOR ROLLER - PART NO. 89422-07
 - 8- BRIDGE CASTING FOR ROLLER - PART NO. 89422-08
 - 9- BRIDGE CASTING FOR ROLLER - PART NO. 89422-09
 - 10- BRIDGE CASTING FOR ROLLER - PART NO. 89422-10
 - 11- BRIDGE CASTING FOR ROLLER - PART NO. 89422-11
 - 12- BRIDGE CASTING FOR ROLLER - PART NO. 89422-12
 - 13- BRIDGE CASTING FOR ROLLER - PART NO. 89422-13
 - 14- BRIDGE CASTING FOR ROLLER - PART NO. 89422-14
 - 15- BRIDGE CASTING FOR ROLLER - PART NO. 89422-15
 - 16- BRIDGE CASTING FOR ROLLER - PART NO. 89422-16
 - 17- BRIDGE CASTING FOR ROLLER - PART NO. 89422-17
 - 18- BRIDGE CASTING FOR ROLLER - PART NO. 89422-18
 - 19- BRIDGE CASTING FOR ROLLER - PART NO. 89422-19
 - 20- BRIDGE CASTING FOR ROLLER - PART NO. 89422-20

	CLEVELAND TRACK MATERIAL, INC. 8527 BROADVIEW AVE. CLEVELAND, OHIO 44107		WWW.CLEVELANDTRACKMATERIAL.COM		SHEET NO. C-83126 SHEET 1 OF 2

GENERAL NOTES:

- 1- SINCE THERE IS SOME DEFORMATION OF MANGANESE STEEL IN WORK HARDENING, WE RECOMMEND THE INSPECTION OF THE RUNNING SURFACES OF THE BRIDGE JOINTS PERIODICALLY. ANY ROLLED OVER EDGES SHOULD BE GROUND SMOOTH, AND THE CORNERS ROUNDED TO PERVENT FORMATION OF CRACKS IN THE CASTING.
- 2- CASTING TO BE MANGANESE STEEL ASTM SPEC. A-128-LATEST REV.

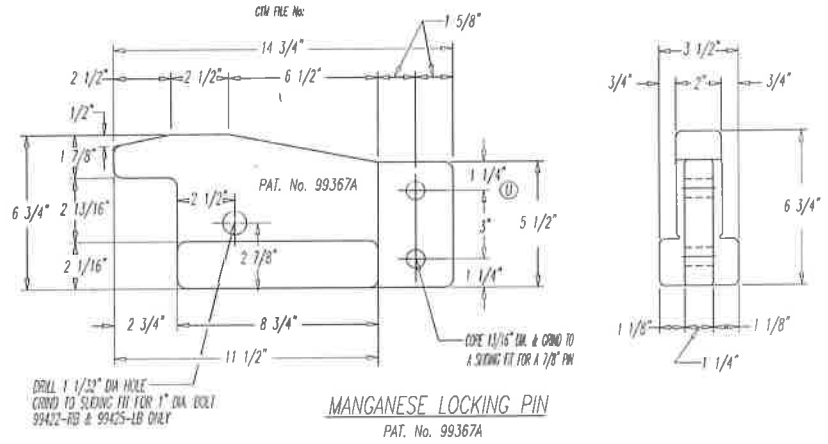

PATTERN MAKER NOTES:

- PATTERN MAKER SHALL ALLOW 1/16" FINISH JOINT BAR FIT
- PATTERN MAKER SHALL ALLOW 3/32" FINISH ON GAGE LINE.
- PATTERN MAKER SHALL ALLOW 3/32" FINISH ON PAD SURFACES.
- PATTERN MAKER SHALL ALLOW 3/32" FINISH ON BOTTOM SURFACES.
- PATTERN MAKER SHALL ALLOW 9/32" FINISH ON TOP SURFACES.
- MINIMUM FILLET RADIUS TO BE 1/2"
- MINIMUM CORNER RADIUS TO BE 3/8"

REFERENCE

- PATTERNS FOR SETUP "B" :DWG. NO. CTM C-83126 SH 1 OF 5
- SECTIONS FOR ASS'Y PLAN :DWG. NO. CTM C-83126 SH 2 OF 7
- LAYOUT SHEET FOR LH & RH ROCKERS, CTM DWG. C-83126, SH. 3 OF 7
- LAYOUT SHEET FOR LH & RH FIXED POINT, CTM DWG. C-83126, SH. 4 OF 7
- LAYOUT SHEET FOR LH & RH MOVABLE POINT, CTM DWG. C-83126, SH. 5 OF 7
- PATTERN CHANGES, CTM DWG. C-83126, SH. 7 OF 7
- LAYOUT SHEET FOR 133RE 3-PIECE MANGANESE BRIDGE JOINTS, CTM DRAWING: C-8350
- LAYOUT SHEET FOR LH & RH ROCKERS, CTM DWG: B-8305C
- LAYOUT SHEET FOR LOCKING PIN 99367, CTM DWG: B-8345A

DRAWING NO. 99367A TITLE MANGANESE LOCKING PIN SCALE 1" = 1-5/8" DATE 1-25-57 DRAWN BY CHECKED BY APPROVED BY				CLEVELAND TRACK MATERIAL INC. 8475 BUCKINGHAM AVE. CLEVELAND, OHIO 44137		DRAWING NO. 99367A TITLE MANGANESE LOCKING PIN SCALE 1" = 1-5/8" DATE 1-25-57 DRAWN BY CHECKED BY APPROVED BY		SHEET NO. 1 OF 2	
---	--	--	--	--	--	---	--	---------------------	--

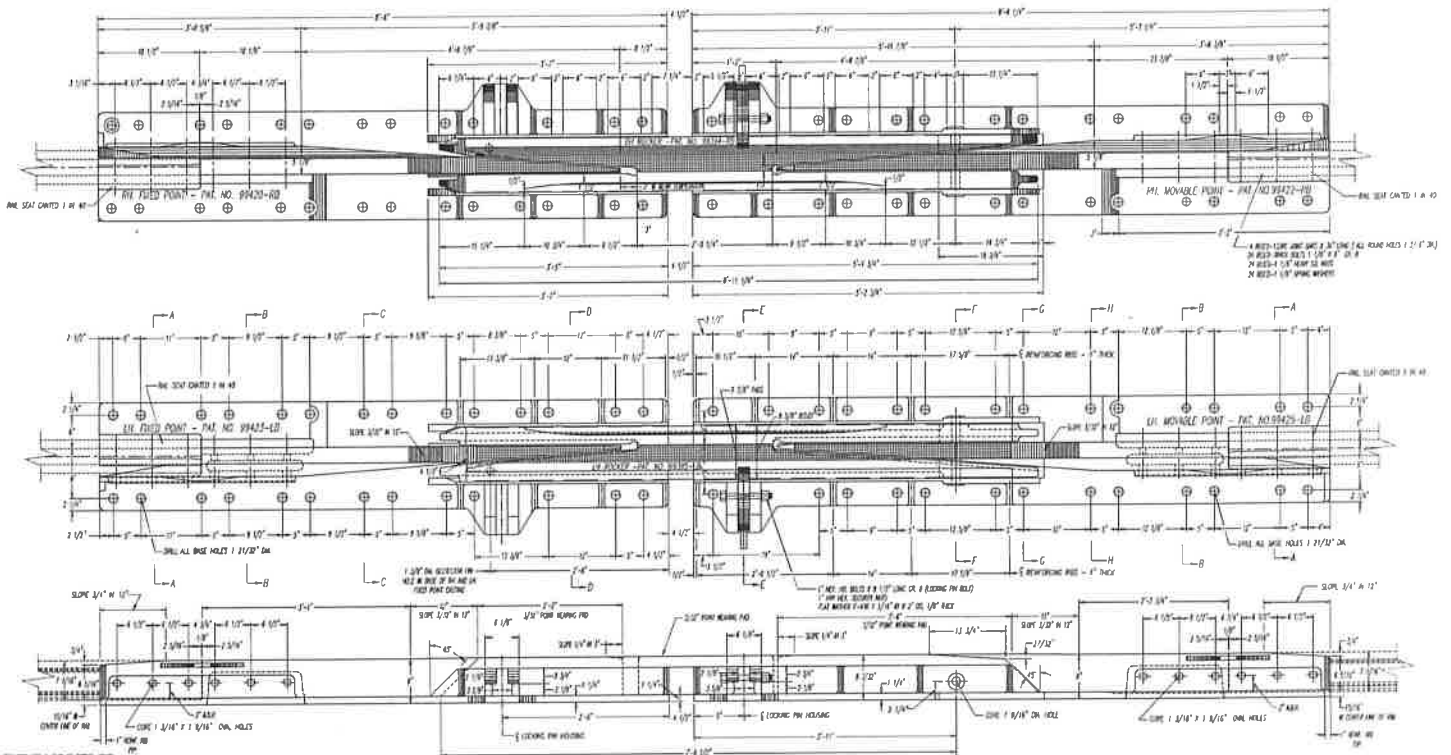

DETAILS REQUIRED FOR LAYOUT OF BRIDGE APPROACH

NO.	DESCRIPTION	NO.	DESCRIPTION
1	BRIDGE APPROACH TO MAIN SPAN	1	BRIDGE APPROACH TO MAIN SPAN
2	BRIDGE APPROACH TO MAIN SPAN	2	BRIDGE APPROACH TO MAIN SPAN
3	BRIDGE APPROACH TO MAIN SPAN	3	BRIDGE APPROACH TO MAIN SPAN
4	BRIDGE APPROACH TO MAIN SPAN	4	BRIDGE APPROACH TO MAIN SPAN
5	BRIDGE APPROACH TO MAIN SPAN	5	BRIDGE APPROACH TO MAIN SPAN
6	BRIDGE APPROACH TO MAIN SPAN	6	BRIDGE APPROACH TO MAIN SPAN
7	BRIDGE APPROACH TO MAIN SPAN	7	BRIDGE APPROACH TO MAIN SPAN
8	BRIDGE APPROACH TO MAIN SPAN	8	BRIDGE APPROACH TO MAIN SPAN
9	BRIDGE APPROACH TO MAIN SPAN	9	BRIDGE APPROACH TO MAIN SPAN
10	BRIDGE APPROACH TO MAIN SPAN	10	BRIDGE APPROACH TO MAIN SPAN
11	BRIDGE APPROACH TO MAIN SPAN	11	BRIDGE APPROACH TO MAIN SPAN
12	BRIDGE APPROACH TO MAIN SPAN	12	BRIDGE APPROACH TO MAIN SPAN
13	BRIDGE APPROACH TO MAIN SPAN	13	BRIDGE APPROACH TO MAIN SPAN
14	BRIDGE APPROACH TO MAIN SPAN	14	BRIDGE APPROACH TO MAIN SPAN
15	BRIDGE APPROACH TO MAIN SPAN	15	BRIDGE APPROACH TO MAIN SPAN
16	BRIDGE APPROACH TO MAIN SPAN	16	BRIDGE APPROACH TO MAIN SPAN
17	BRIDGE APPROACH TO MAIN SPAN	17	BRIDGE APPROACH TO MAIN SPAN
18	BRIDGE APPROACH TO MAIN SPAN	18	BRIDGE APPROACH TO MAIN SPAN
19	BRIDGE APPROACH TO MAIN SPAN	19	BRIDGE APPROACH TO MAIN SPAN
20	BRIDGE APPROACH TO MAIN SPAN	20	BRIDGE APPROACH TO MAIN SPAN

- GENERAL NOTES**
1. ALL MATERIALS SHOWN SHALL MEET THE GENERAL REQUIREMENTS OF AISC AS SET FORTH IN THE LATEST EDITION OF THE MANUAL.
 2. UNLESS OTHERWISE SPECIFIED, ALL DIMENSIONS SHALL BE IN FEET AND INCHES.
 3. DIMENSIONS SHALL BE EXPRESSED IN FEET AND INCHES TO THE NEAREST 1/8" UNLESS OTHERWISE SPECIFIED.
 4. DIMENSIONS SHALL BE EXPRESSED IN FEET AND INCHES TO THE NEAREST 1/8" UNLESS OTHERWISE SPECIFIED.
 5. DIMENSIONS SHALL BE EXPRESSED IN FEET AND INCHES TO THE NEAREST 1/8" UNLESS OTHERWISE SPECIFIED.
 6. DIMENSIONS SHALL BE EXPRESSED IN FEET AND INCHES TO THE NEAREST 1/8" UNLESS OTHERWISE SPECIFIED.
 7. DIMENSIONS SHALL BE EXPRESSED IN FEET AND INCHES TO THE NEAREST 1/8" UNLESS OTHERWISE SPECIFIED.
 8. DIMENSIONS SHALL BE EXPRESSED IN FEET AND INCHES TO THE NEAREST 1/8" UNLESS OTHERWISE SPECIFIED.
 9. DIMENSIONS SHALL BE EXPRESSED IN FEET AND INCHES TO THE NEAREST 1/8" UNLESS OTHERWISE SPECIFIED.
 10. DIMENSIONS SHALL BE EXPRESSED IN FEET AND INCHES TO THE NEAREST 1/8" UNLESS OTHERWISE SPECIFIED.
 11. DIMENSIONS SHALL BE EXPRESSED IN FEET AND INCHES TO THE NEAREST 1/8" UNLESS OTHERWISE SPECIFIED.
 12. DIMENSIONS SHALL BE EXPRESSED IN FEET AND INCHES TO THE NEAREST 1/8" UNLESS OTHERWISE SPECIFIED.
 13. DIMENSIONS SHALL BE EXPRESSED IN FEET AND INCHES TO THE NEAREST 1/8" UNLESS OTHERWISE SPECIFIED.
 14. DIMENSIONS SHALL BE EXPRESSED IN FEET AND INCHES TO THE NEAREST 1/8" UNLESS OTHERWISE SPECIFIED.
 15. DIMENSIONS SHALL BE EXPRESSED IN FEET AND INCHES TO THE NEAREST 1/8" UNLESS OTHERWISE SPECIFIED.
 16. DIMENSIONS SHALL BE EXPRESSED IN FEET AND INCHES TO THE NEAREST 1/8" UNLESS OTHERWISE SPECIFIED.
 17. DIMENSIONS SHALL BE EXPRESSED IN FEET AND INCHES TO THE NEAREST 1/8" UNLESS OTHERWISE SPECIFIED.
 18. DIMENSIONS SHALL BE EXPRESSED IN FEET AND INCHES TO THE NEAREST 1/8" UNLESS OTHERWISE SPECIFIED.
 19. DIMENSIONS SHALL BE EXPRESSED IN FEET AND INCHES TO THE NEAREST 1/8" UNLESS OTHERWISE SPECIFIED.
 20. DIMENSIONS SHALL BE EXPRESSED IN FEET AND INCHES TO THE NEAREST 1/8" UNLESS OTHERWISE SPECIFIED.

REFERENCE

STEEL BRIDGE DESIGN MANUAL, 1945 EDITION, PART I, CHAPTER 10, SECTION 10.1.1, 10.1.2, 10.1.3, 10.1.4, 10.1.5, 10.1.6, 10.1.7, 10.1.8, 10.1.9, 10.1.10, 10.1.11, 10.1.12, 10.1.13, 10.1.14, 10.1.15, 10.1.16, 10.1.17, 10.1.18, 10.1.19, 10.1.20, 10.1.21, 10.1.22, 10.1.23, 10.1.24, 10.1.25, 10.1.26, 10.1.27, 10.1.28, 10.1.29, 10.1.30, 10.1.31, 10.1.32, 10.1.33, 10.1.34, 10.1.35, 10.1.36, 10.1.37, 10.1.38, 10.1.39, 10.1.40, 10.1.41, 10.1.42, 10.1.43, 10.1.44, 10.1.45, 10.1.46, 10.1.47, 10.1.48, 10.1.49, 10.1.50, 10.1.51, 10.1.52, 10.1.53, 10.1.54, 10.1.55, 10.1.56, 10.1.57, 10.1.58, 10.1.59, 10.1.60, 10.1.61, 10.1.62, 10.1.63, 10.1.64, 10.1.65, 10.1.66, 10.1.67, 10.1.68, 10.1.69, 10.1.70, 10.1.71, 10.1.72, 10.1.73, 10.1.74, 10.1.75, 10.1.76, 10.1.77, 10.1.78, 10.1.79, 10.1.80, 10.1.81, 10.1.82, 10.1.83, 10.1.84, 10.1.85, 10.1.86, 10.1.87, 10.1.88, 10.1.89, 10.1.90, 10.1.91, 10.1.92, 10.1.93, 10.1.94, 10.1.95, 10.1.96, 10.1.97, 10.1.98, 10.1.99, 10.1.100.

CLEVELAND TRACK MATERIAL, INC.
 8919 DENVER AVE.
 CLEVELAND, OHIO 44187

WESTCH

FOR LIFT BRIDGE
 EXPLOSION HARDY
 BRIDGE BRIDGE

NO. 8-83127

SHEET 1 OF 2

LOCAL BUSINESS PREFERENCE PROGRAM

The Harbor Department is committed to maximizing opportunities for local and regional businesses, as well as encouraging local and regional businesses to locate and operate within the Southern California region. It is the policy of the Harbor Department to support an increase in local and regional jobs. The Harbor Department's Local Business Preference Program (LBPP) aims to benefit the Southern California region by increasing jobs and expenditures within the local and regional private sector.

Contractors who qualify as a Local Business Enterprise (LBE) will receive an 8% preference on any bid for goods, materials, supplies, and related services valued in excess of \$150,000. The preference will be applied by calculating the bidder's price at 8% less than the quoted price. The Harbor Department will use the applied preference for bid tabulation only. The actual amount paid to the lowest bidder will be the price quoted by the lowest bidder meeting specifications.

Contractors who do not qualify as a LBE may receive a maximum 5% preference for identifying and utilizing LBE subcontractors. Contractors may receive 1% preference, up to a maximum of 5%, for every 10% of or portion thereof, of work that is subcontracted to a LBE.

The Harbor Department defines a LBE as:

- (a) A business headquartered within Los Angeles, Orange, Riverside, San Bernardino, or Ventura Counties. Headquartered shall mean that the business physically conducts and manages all of its operations from a location in the above-named counties; or
- (b) A business that has at least 50 full-time employees, or 25 full-time employees for specialty marine contracting firms, working in Los Angeles, Orange, Riverside, San Bernardino, or Ventura Counties.

In order for Harbor Department staff to determine the appropriate LBE preference, Vendor shall complete, sign, notarize and submit the attached Affidavit and Contractor Description Form. The Affidavit and Contractor Description Form will signify the LBE status of the Contractor and any subcontractors.

In the event of Contractor's noncompliance during the performance of the Contract, Contractor shall be considered in material breach of contract. In addition to any other remedy available to City under this Contract or by operation of law, the City may withhold invoice payments to Contractor until noncompliance is corrected, and assess the costs of City's audit of books and records of Contractor. In the event the Contractor falsifies or misrepresents information contained in any form or other willful noncompliance as determined by City, City may disqualify the Contractor from participation in City contracts for a period of up to five (5) years.

AFFIDAVIT OF COMPANY STATUS

"The undersigned declares under penalty of perjury pursuant to the laws of the State of California that the following information is true and correct and includes all material information necessary to identify and explain the operations of

Cleveland Track Material, Inc.

Name of Firm

as well as the ownership and location thereof. Further, the undersigned agrees to provide complete and accurate information regarding ownership in the named firm, any proposed changes of the ownership and to permit the audit and examination of firm ownership documents in association with this contract."

Local Business Preference Program: Please indicate the Local Business Enterprise status of your company. Only one box must be checked:

LBE Non-LBE

- A Local Business Enterprise (LBE) is: (a) a business headquartered within Los Angeles, Orange, Riverside, San Bernardino, or Ventura Counties; or (b) a business that has at least 50 full-time employees, or 25 full-time employees for specialty marine contracting firms, working in Los Angeles, Orange, Riverside, San Bernardino, or Ventura Counties. "Headquartered" shall mean that the business physically conducts and manages all of its operations from a location in the above-named counties.
- A Non-LBE is any business that does not meet the definition of a LBE.

Signature: _____



Title: _____

CEO

Printed Name: _____

Eliseo Bandala

Date Signed: _____

2-7-19

Contractor Description Form

PRIME CONTRACTOR:

Contract Title: Badger Avenue Bridge Miter Joints
Business Name: Cleveland Truck Material, Inc. Award Total: \$ _____
Local Business Enterprise: YES _____ NO (Check only one)
Address: 6600 Bessemer Ave.
City/State/Zip: Cleveland OH
County: Cuyahoga
Telephone: (216) 441 4000 FAX: (216) 441 7507
Contact Person/Title: Bruce Buzzard
Email Address: bruce.buzzard@rosslab.com

SUBCONTRACTOR:

Business Name: _____ Award Total: \$ _____
Services to be provided: _____
Local Business Enterprise: YES _____ NO _____ (Check only one)
Address: _____
City/State/Zip: _____
County: _____
Telephone: () _____ FAX: () _____
Contact Person/Title: _____
Email Address: _____

SUBCONTRACTOR:

Business Name: _____ Award Total: \$ _____
Services to be provided: _____
Local Business Enterprise: YES _____ NO _____ (Check only one)
Address: _____
City/State/Zip: _____
County: _____
Telephone: () _____ FAX: () _____
Contact Person/Title: _____
Email Address: _____

SUBCONTRACTOR:

Business Name: _____ Award Total: \$ _____
Services to be provided: _____
Local Business Enterprise: YES _____ NO _____ (Check only one)
Address: _____
City/State/Zip: _____
County: _____
Telephone: () _____ FAX: () _____
Contact Person/Title: _____
Email Address: _____

SUBCONTRACTOR:

Business Name: _____ Award Total: \$ _____
Services to be provided: _____
Local Business Enterprise: YES _____ NO _____ (Check only one)
Address: _____
City/State/Zip: _____
County: _____
Telephone: () _____ FAX: () _____
Contact Person/Title: _____
Email Address: _____

ACKNOWLEDGMENT

A notary public or other officer completing this certificate verifies only the identity of the individual who signed the document to which this certificate is attached, and not the truthfulness, accuracy, or validity of that document.

State of ~~California~~ Ohio
County of Cuyahoga

On February 7, 2019 before me, Eliseo Bandala, CEO
(insert name and title of the officer)

personally appeared _____
who proved to me on the basis of satisfactory evidence to be the person(s) whose name(s) is/are subscribed to the within instrument and acknowledged to me that he/she/they executed the same in his/her/their authorized capacity(ies), and that by his/her/their signature(s) on the instrument the person(s), or the entity upon behalf of which the person(s) acted, executed the instrument.

I certify under PENALTY OF PERJURY under the laws of the State of California that the foregoing paragraph is true and correct.

WITNESS my hand and official seal.

Signature Sandra Reik



SANDRA REIK
NOTARY PUBLIC, STATE OF OHIO
Recorded in Cuyahoga County
My Comm. Expires May 5, 2019

RESOLUTIONS

CLEVELAND TRACK MATERIAL, INC.

The undersigned, being all of the Directors of CLEVELAND TRACK MATERIAL, INC., an Ohio corporation (the "Corporation"), hereby take and adopt the following actions, in writing and without a meeting, pursuant to the authority of the Corporation's Charter and Bylaws and Ohio law:

WHEREAS, the Corporation is party to that certain Credit and Security Agreement, dated as of July 25, 2002, as amended and restated on June 3, 2005, with KEYBANK NATIONAL ASSOCIATION ("Lender") that provides, among other things, for a demand line of credit aggregating Seven Million Dollars (\$7,000,000), all upon certain terms and conditions (as amended and as the same may from time to time be further amended, restated or otherwise modified, the "Credit Agreement");

WHEREAS, the Corporation and Lender desire to amend the Credit Agreement to modify certain provisions thereof and add certain provisions thereto pursuant to the Seventh Amendment Agreement, between the Corporation and Lender, dated as of March 25, 2011 (the "Amendment");

WHEREAS, the Corporation has considered the value to itself and the business benefit that it expects to receive from the financial accommodations granted pursuant to the Credit Agreement, as amended by the Amendment, and deems it to be in the direct pecuniary and business interests of the Corporation that the Corporation continue to obtain from Lender the financial accommodations provided for thereunder;

WHEREAS, the Corporation has negotiated, reviewed and approved the terms of the documentation relating to the Amendment, and the Corporation has determined it is in its best interest to enter into the transactions contemplated thereby;

WHEREAS, the consummation of the transactions contemplated by the Amendment are desirable and in the best interests of the Corporation, and the Corporation will benefit from the loans and other financial accommodations provided to the Corporation under the Credit Agreement, as amended by the Amendment;

NOW, THEREFORE, BE IT:

RESOLVED, that William B. Sturtz, the Chief Executive Officer of the Corporation, William F. Willoughby, the Chief Operating Officer of the Corporation, Martin Neumann, the Chief Financial Officer of the Corporation, or any other officer of the Corporation, acting alone or with any other officer(s) of the Corporation, is authorized and empowered, for and on behalf of the Corporation, to enter into, make, accept, acknowledge, execute and deliver to Lender the Amendment and Notes and any other such agreements, notes, certificates or other documents ("Documents") that may be required or helpful in connection with the Amendment or the Credit

Agreement, and the Documents shall contain terms acceptable to the Corporation, such acceptance by and approval of the Board of Directors of the Corporation being conclusively evidenced by such officer's execution thereof;

RESOLVED FURTHER, that any officer of the Corporation, either alone or in conjunction with any other officer(s) of the Corporation, is authorized and empowered, for and on behalf of the Corporation, to execute and deliver, and to perform under, all documents, instruments, agreements and certificates, related to or contemplated by any of the Documents, each such document, instrument, agreement and certificate being in a form acceptable to such officer(s), and the approval thereof by the Board of Directors being conclusively evidenced by such officers' execution thereof;

RESOLVED FURTHER, that any officer of the Corporation, either alone or in conjunction with any other officer(s) of the Corporation, is authorized and empowered, for and on behalf of the Corporation, to execute and deliver any and all required amendments, waivers, consents and other agreements under any credit facility, credit agreement, indenture, note, note purchase agreement, lease or other agreement to which the Corporation is a party as such officer may deem necessary or desirable to carry out the intent of the foregoing resolutions;

RESOLVED FURTHER, that any officer of the Corporation, either alone in conjunction with any other officer(s) of the Corporation, is authorized and empowered, for and on behalf of the Corporation, to do and perform such other acts and things and to make, execute, deliver, file and record such other agreements, instruments, certificates and documents, and to pay such fees, costs and expenses, as may in such officer's judgment be necessary or appropriate to carry out and comply with, or evidence compliance with, the terms, conditions and provisions of the resolutions, the Documents, and such other agreements, documents and instruments as may be delivered by the Corporation in connection therewith;

RESOLVED FURTHER, that all of the acts performed, and the agreements, facilities, instruments, documents, schedules, and certificates negotiated, executed, delivered or performed, by any of the officers of the Corporation, for and on behalf of the Corporation, in connection with the Documents, the transactions contemplated thereby, or the actions described or referenced to in these resolutions, whether heretofore or hereafter done or performed, which are in conformity with the intent and purposes of the resolutions, are ratified, confirmed and approved in all respects; and

RESOLVED FURTHER, that Lender may rely on each of the foregoing resolutions remaining in full force and effect until otherwise notified by an officer of the Corporation.

These Resolutions may be executed in one or more counterparts and may be executed via electronic or facsimile transmission.

[Remainder of page intentionally left blank]

Dated March 25, 2011

William B. Hunt
M. J. M. M. M.
John C. ...

BEING ALL OF THE DIRECTORS OF
CLEVELAND TRACK MATERIAL,
INC.



425 S. Palms Verdes Street Post Office Box 151 San Pedro, CA 90733-0151 TEL/TDD 310 SEA-PORT www.portoflosangeles.org

Eric Garcetti

Mayor, City of Los Angeles

Board of Harbor
Commissioners

Jaime L. Lee
President

Lucia Moreno-Uncas
Commissioner

Anthony Prozzi, Jr.
Commissioner

Edward R. Renwick
Commissioner

Eugene D. Seroka

Executive Director

DATE: January 23, 2019

BID ADDENDUM #1, Bid No.: F-1035 DESCRIPTION: "BADGER AVENUE BRIDGE MITER JOINTS"

BID OPENING DATE: Tuesday, January 29, 2019 2 p.m.

Revised Bid Opening Date: Tuesday, February 12, 2019 2 p.m

All other specifications, terms, and conditions shall remain the same.

Address questions to Buyer: Jacquelyn Estrada, (310) 732-3521, jestrada@portla.org.

Please attach this addendum to your bid.

Regards,

Jacquelyn L. Estrada
Procurement Analyst



425 S. Palos Verdes Street Post Office Box 151 San Pedro, CA 90733-0151 TEL/TDD 310 SEA-PORT www.portoflosangeles.org

Eric Garcetti Mayor, City of Los Angeles

Board of Harbor Commissioners

Jaime L. Lee President

Diane L. Middleton Commissioner

Lucia Moreno-Linares Commissioner

Anthony Pirozzi, Jr. Commissioner

Edward R. Renwick Commissioner

Eugene D. Seroka

Executive Director

Vossloh North America
Cleveland Track Material Inc.
Attention: Bruce Buzzard
6917 Bessemer Avenue
Cleveland, OH 44127

Via Email: bruce.buzzard@vossloh.com

RE: ADDENDUM #2, BID NO. F-1035: BADGER BRIDGE MITER JOINTS

THE FOLLOWING TERMS ARE ACCEPTED AND INCORPORATED BY REFERENCE TO LOS ANGELES HARBOR DEPARTMENT BID F-1035:

WARRANTY. Terms of warranty on equipment offered. Free PARTS & SERVICE (LABOR) for defective parts and workmanship for the following time period after equipment has been accepted:

1 year

Form with handwritten entries: Firm Name Cleveland Track Material, Inc; Phone 216-641-4000; Fax 216-441-7507; Address 6600 Bessemer Ave., Cleveland OH 44127; Signature [Handwritten]; Printed Name Eliseo Bandala; Printed Title CEO

Thank you for your cooperation. Should you have any questions or concerns regarding this addendum, feel free to contact me at: (310) 732-3521 or jestrada@portla.org.

Very respectfully,

[Handwritten signature of Jacquelyn L. Estrada]

JACQUELYN L. ESTRADA
Procurement Analyst

51557



425 S. Palos Verdes Street Post Office Box 151 San Pedro, CA 90733-0151 TEL/TDD 310 SEA-PORT www.portoflosangeles.org

Eric Garcetti Mayor, City of Los Angeles

Board of Harbor Commissioners

Jaime L. Lee President

Diane L. Middleton Commissioner

Lucia Moreno-Linares Commissioner

Anthony Pirozzi, Jr. Commissioner

Edward R. Renwick Commissioner

Eugene D. Seroka

Executive Director

July 31, 2019

Vossloh North America
Cleveland Track Material Inc.
Attention: Bruce Buzzard
6917 Bessemer Avenue
Cleveland, OH 44127

Via Email: bruce.buzzard@vossloh.com

RE: ADDENDUM #3, BID NO. F-1035: BADGER BRIDGE MITER JOINTS

THE FOLLOWING TERMS ARE ACCEPTED AND INCORPORATED BY REFERENCE TO LOS ANGELES HARBOR DEPARTMENT BID F-1035:

TIME OF DELIVERY

State time of delivery: 480 days after receipt of order. Terms: .5 % discount for payments within 10 days.

ALL OTHER TERMS REMAIN UNCHANGED.

Firm Name Cleveland Track Material Inc.
Phone 216-641-4000 Fax
Address 6600 Bessemer Ave. Cleveland, OH 44127
Street City State Zip
Signature R.B. Buzzard Printed Name R.B. Buzzard Printed Title Estimator

Thank you for your assistance. Should you have any questions or concerns regarding this addendum, feel free to contact me at: (310) 732-3521 or jestrada@portla.org.

Very respectfully,

Jacquelyn L. Estrada signature

JACQUELYN L. ESTRADA
Procurement Analyst